

# HP20 HP30 HP60 HP65 HP72 **tecnopress** SERIES

## TECHNICAL DETAILS

Type	Model	Power kW		Electric power supply	Fan motor kW	Pump motor kW	Gas connections
		min.	max.				
HP20	MG.xx.x.xx.A.0.25	85	230	230 V 1N ac	0,37	0,18	1"
HP30	MG.xx.S.xx.A.0.xx	65	350	230 V 1N ac	0,37	0,18	1"¼ - 1"½
HP60	MG.xx.S.xx.A.0.xx	170	880	230/400 V 3N ac	1,10	0,55	1"¼ - 1"½ - 2" - DN65
HP65	MG.xx.S.xx.A.x.xx	270	970	230/400 V 3N ac	1,50	0,55	1"½ - 2" - DN65
HP72	MG.xx.S.xx.A.0.xx	330	1200	230/400 V 3N ac	2,20	0,55	1"½ - 2" - DN65 - DN80
HP72	MG.xx.S.xx.A.1.xx	330	1550	230/400 V 3N ac	2,20	0,55	1"½ - 2" - DN65 - DN80

For the configuration of the gas train, see page 101.

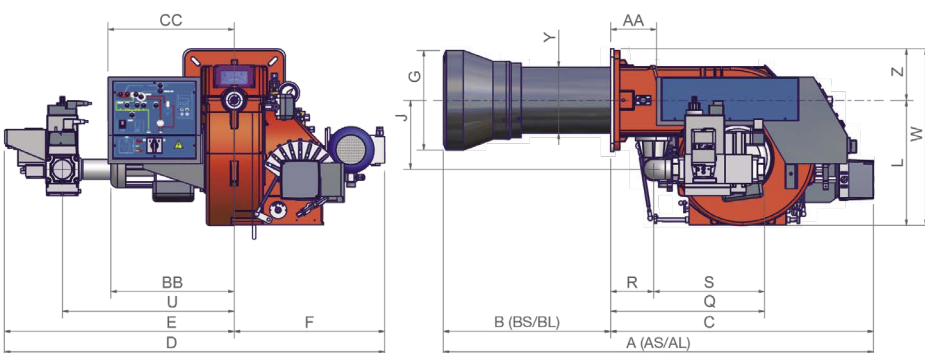

Type	Packaging dimensions (mm)			
	l	p	h	kg
HP20/HP30	980	800	620	75
HP60	1360	930	820	120
HP65	1370	1130	820	130
HP72	1370	1130	820	160

Approximate values

### HP20 - HP30 - HP60

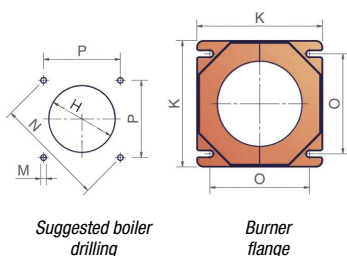

Suggested boiler drilling

Burner flange

### DN65 - DN80

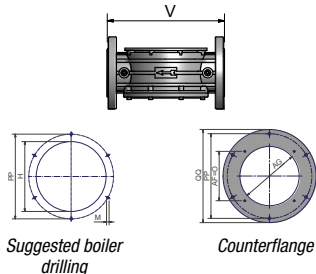

Suggested boiler drilling

Counterflange

### HP65 - HP72

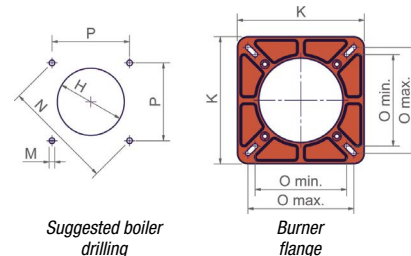

Suggested boiler drilling

Burner flange

Type	Model	Overall dimensions (mm)																															
		AA	AG	AL	AS	BB	BL	BS	C	CC	D	E	F	G	H	J	K	L	M	N	O	P	PP	Q	QQ	R	S	U	V	W	Y	Z	
																				min.		max.											
HP20	MG.xx.x.xx.A.0.25	-	-	813	728	-	258	173	555	-	830	510	320	126	151	178	190	290	M10	219	155	155	155	-	-	-	-	-	360	-	-	115	-
HP30	MG.xx.S.xx.A.0.xx	-	-	855	-	-	300	555	-	830	510	320	150	162	178	190	290	M10	219	155	155	155	-	-	-	-	-	360	-	-	133	-	
HP60	MG.xx.S.xx.A.0.32	99	-	1119	314	-	383	736	362	930	500	430	240	280*	210	240	344	M10	269	190	190	190	-	445	-	112	327	444	-	464	162	120	
HP60	MG.xx.S.xx.A.0.40	99	-	1119	314	-	383	736	362	930	500	430	240	280*	210	240	344	M10	269	190	190	190	-	445	-	112	327	444	-	464	162	120	
HP60	MG.xx.S.xx.A.0.50	99	-	1119	314	-	383	736	362	930	500	430	240	280*	210	240	344	M10	269	190	190	190	-	445	-	112	335	444	-	464	162	120	
HP60	MG.xx.S.xx.A.0.65	99	-	1119	314	-	383	736	362	1115	685	430	240	280*	250	240	420	M10	269	190	190	190	-	845	-	112	403	540	292	540	162	120	
HP65	MG.xx.S.xx.A.1.40	139	-	1156	347	-	362	794	380	1148	694	454	240	280	208	300	376	M10	330	216	250	233	-	457	-	130	327	519	-	531	162	155	
HP65	MG.xx.S.xx.A.1.50	139	-	1156	347	-	362	794	380	1148	694	454	240	280	208	300	376	M10	330	216	250	233	-	465	-	130	335	519	-	531	162	155	
HP65	MG.xx.S.xx.A.1.65	139	-	1156	347	-	362	794	380	1226	772	454	240	280	275	300	393	M10	330	216	250	233	-	533	-	130	403	565	292	548	162	155	
HP72	MG.xx.S.xx.A.0.40	139	-	1299	373	-	505	794	382	1022	568	454	300	340*	208	300	376	M10	330	216	250	233	400	465	440	130	335	519	-	531	198	155	
HP72	MG.xx.S.xx.A.0.50	139	-	1299	373	-	505	794	382	1022	568	454	300	340*	208	300	376	M10	330	216	250	233	400	457	440	130	327	519	-	531	198	155	
HP72	MG.xx.S.xx.A.0.65	139	-	1299	373	-	505	794	382	1120	666	454	300	340*	275	300	393	M10	330	216	250	233	400	533	440	130	403	565	292	548	198	155	
HP72	MG.xx.S.xx.A.0.80	139	-	1299	373	-	505	794	382	1120	666	454	300	340*	275	300	407	M10	330	216	250	233	400	574	440	130	444	565	310	562	198	155	
HP72	MG.xx.S.xx.A.1.40	139	-	1299	373	-	505	794	382	1148	694	454	300	340*	208	300	376	M10	330	216	250	233	400	465	440	130	335	519	-	531	198	155	
HP72	MG.xx.S.xx.A.1.50	139	-	1299	373	-	505	794	382	1148	694	454	300	340*	208	300	376	M10	330	216	250	233	400	457	440	130	327	519	-	531	198	155	
HP72	MG.xx.S.xx.A.1.65	139	-	1299	373	-	505	794	382	1226	772	454	300	340*	275	300	393	M10	330	216	250	233	400	533	440	130	403	565	292	548	198	155	
HP72	MG.xx.S.xx.A.1.80	139	-	1299	373	-	505	794	382	1228	774	454	300	340*	275	300	407	M10	330	216	250	233	400	574	440	130	444	565	310	562	198	155	

• Install a counter-flange between the burner and the boiler or in alternative, drill the H hole smaller but higher than the Y point and assemble the combustion head inside the boiler.

Approximate values