

Siemens LMV 5x



Service manual



BURNERS PROVIDED WITH SIEMENS LMV5

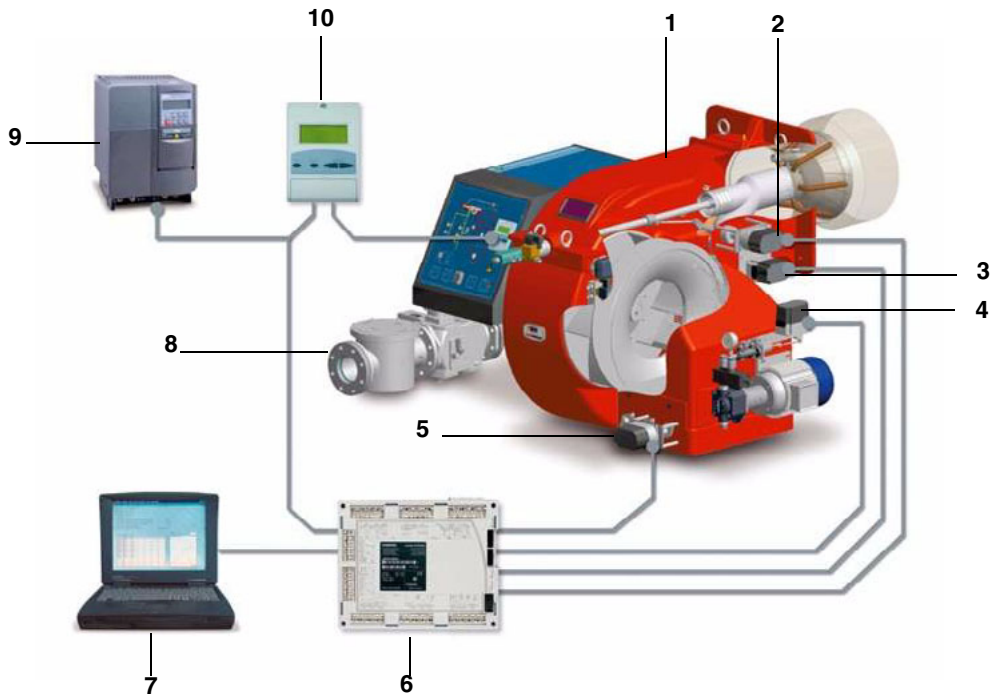

Keys

- 1 Burner
- 2 Combustion head actuator
- 3 Gas butterfly valve actuator
- 4 Oil pressure governor actuator
- 5 Air damper actuator
- 6 Siemens LMV burner control
- 7 Personal Computer
- 8 Gas train
- 9 Inverter
- 10 Siemens AZL User interface

The control system is made of the Siemens LMV central unit (6) that performs all the burner control functions and of the Siemens AZL local programming unit (10) that interfaces the system with the user.

Main features:

- no mechanical linkages
- built-in burner control box
- built-in gas proving system
- more flame checking devices available for several applications
- PID load controller
- up to six actuators can be controlled. Each of them is independent for the best burner setup
- best air/fuel ratio. Repeatability and precision of set adjustments
- Modbus communication
- multilevel password
- settings via PC
- adjustable prepurging time (according to the relevant Standards)
- continuous ventilation
- post purging (adjustable time)
- proving system settable to on and off
- adjustable proving system time for all the valve volumes
- load controller settable to on and off
- thermal shock protection function settable to on and off (for cold starts)
- continuous operation



Note: the picture above shows a complete control system.

AZL display/programming unit

Users can set only the LMV parameters that can be accessed without password: (see “Adjusting the temperature set-point”). The Siemens AZL User Interface allows programming the Siemens LMV control box and monitoring the system data.



The user interface is made of:

1. display: it shows menus and parameters
2. **ESC**  key (previous level): it goes back to the previous level menu or exits the programming mode without changing data.
3. **ENTER**  key (next level): it confirms the data changing and jumps to the next menu/parameter.
4. **SELECT**  keys: they select a menu item and change the parameter values.

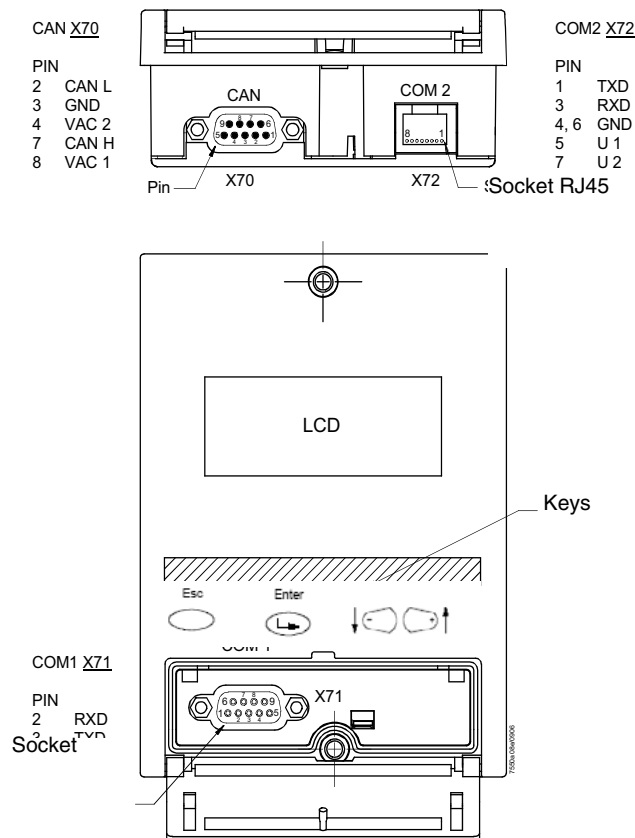

AZL5x provides three sockets to interface with other devices:

- X70 socket for CAN bus connection: it provides power supply to display also.
- COM1 (X71) for connection to PC/laptop by RS232 connector
- COM2 (X72) for connection to building automation system by RJ45 connector.

Note: COM1 and COM2 ports do not work at the same time.



Caution: when MODBUS is active, it is not possible to execute the backup via ACS450; if backup is executed the setpoint will be missing and the burner will immediately turn off.

LMV5 program operating phases

The AZL user interface, shows the program operating phases in the following order

HOME RUN (Phase 10)
STAND BY (Phase 12)
STARTUP I (Phases 20, 21) **Waiting for Start Release**
STARTUP II (Phase 22) **Start Fan on**
STARTUP III (Phase 24) **Driving to Pre-purging**
STARTUP IV (Phases 30 ... 34) **Pre-purging**
STARTUP V (Phase 36) **Driving to Ignition Pos**
STARTUP VI (Phase 38) **Ignition Pos**
STARTUP VII (Phases 40, 42, 44) **Fuel Release1**
STARTUP VIII (Phases 50, 52) **Fuel Release2**
STARTUP IX (Phase 54) **Driving to Low-fire**
OPERATION I (Phase 60)
OPERATION II (Phase 62) **Shut-down Low-fire**
SHUTDOWN (Phase 70)
SHUTDOWN (Phase 72) **Driving to Postpurge**
SHUTDOWN (Phases 74...78) **Postpurging**
SHUTDOWN (Phase 79) **Test Air PressSwitch**
VALVE PROVING (Phases 80 ... 83)
SAFETY PHASE (Phase 01)
LOCKOUT (Phase 00)

At burner startup, the AZL display will show the various phases of the startup program one by one, until it reaches normal operation phase (Phase 60).

LMV5x controller is factory set. By closing the thermostatic series and once the startup sequence is accomplished (from phase 12 to phase 34), the burner is driven to the factory-set ignition position (phase 38).

Then the fuel/air ratio curve must be set, until the maximum load limit (100% output). During the setting, the actuators move to position according to the curve points set. While the actuators move, always check the combustion analysis, point by point, and the flame stability. In this phase, some temporary points can be set and cancelled successively. Once the requested output is reached, the curve could be optimised according to the flue gas analysis.

It is recommended to check the gas flow rate on each curve point in order that it corresponds to the actual burner output at that point.

Once all the curve points are set, LMV will set the points according to the output increasing order.

Example: if Point4 is set at 50% load and Point5 at 40% load, LMV will automatically assign Point4 to 40% and Point5 to 50%.



CAUTION! The procedure requires a password: qualified personnel only must check all changes to combustion parameters by means of the combustion analyser. Remember that the password will elapse if no key is pressed for a certain period. The unit will ask for the password again.

LMV5 PROGRAM STRUCTURE



OperationalStat	NormalOperation		
	Status/Reset		
	FaultHistory		
	LockoutHistory		
	Alarm act/deact		
Operation	BoilerSetpoint	<ul style="list-style-type: none"> ● SetpointW1 ● SetpointW2 	
	UserMaxload		
	Fuel		
	Date/TimeOfDay		
	HoursRun		
	StartCounter		
	Fuel Meter		
	LockoutCounter		
	O2 Module		
	BurnerID		
	OptgModeSelect		
	OptgModeSelect		
	ManualOperation	SetLoad	
Autom/Manual/Off			
Params & Display	BurnerControl	<ul style="list-style-type: none"> ● Times ● Configuration ● ValveProving ● ProductID ● SW Version 	
	RatioControl	<ul style="list-style-type: none"> ● GasSettings ● OilSettings ● Au-tom/Manual/Off ● Times ● NumFuelActuators ● ShutdownBehav ● ProgramStop 	
	O2Contr/Guard	<ul style="list-style-type: none"> ● GasSettings ● OilSettings ● Process Data 	
	LoadController	<ul style="list-style-type: none"> ● Controller-Param ● TempLimiter ● ColdStart ● Configuration ● Adaption ● SW Version 	
	AZL	<ul style="list-style-type: none"> ● Times ● Language ● DateFormat ● PhysicalUnits ● eBUS ● Modbus ● Display Contrast ● ProductID ● SW Version 	
	Actuators	<ul style="list-style-type: none"> ● Addressing ● DirectionRot ● ProductID ● SW Version 	

Params & Display	VSD Module	<ul style="list-style-type: none"> ● Configuration ● Process Data ● ProductID ● SW Version 	
	O2 Module	<ul style="list-style-type: none"> ● Configuration ● Displayed Values ● ProductID ● SW Version 	
	Flue Gas Recirc	<ul style="list-style-type: none"> ● 	
	SystemConfig	<ul style="list-style-type: none"> ● LC_ОптgModeРежим с РМ ● Ext Inp X62 U/I ● TempLimiter ● O2Ctrl/LimitrGas ● O2Ctrl/LimitrOil ● LC Analog Output ● Max.Perm.PotDiff 	
	HoursRun		
	StartCounter		
	Fuel Meter		
Updating	Password		
	BurnerID		
	ParamBackup		
	Load_SW_from_PC		
PW Login			
PW Logout			
SafetyCheck-Funct			



ACCESS TO SERVICE LEVELS BY PASSWORD

1 From the main page

Setpoint	80°C
Act.value	78°C
Standby	12

  enter the main menu by pressing the ESC key twice: the display will show

OperationalStat
Operation
ManualOperation
Params & Display.

2    by means of the arrow keys, select "Params&Display", press ENTER: the system will ask you to enter the proper password, if it has not been entered yet:

Access w-out PW
Access Serv
Accesso con OEMAccess
OEM
Accesso con LSAccess LS

3    by means of the arrow keys, select "AccessService" (service level), confirm by pressing ENTER. 

4 insert the Service Level password that is "9876" (default value);

5 To insert a character (number or letter) press the arrow keys until the desired character is reached, then press ENTER to confirm and get the next character (the character entered will not be displayed once confirmed by ENTER). 





6 Repeat the procedure until the password is completed

7 Confirm the password by pressing ENTER again 

8 The display will show

BurnerControl
RatioControl
O2Contr/Guard
LoadController

The access to the 6 menus of the "Service" level is gained.

Attention: the display shows 4 rows at a time, to scroll all the rows use keys   . To enter the submenu/parameter shown on the row press "Enter" , to go back press "Esc" .

To go back to the main menu, press "Esc"  until the first level menu is reached, then press the "right arrow" , until the first item is reached, then press "Enter"  twice.

Password Logout

To avoid customer changes on parameter settings and consequently changes in regulation, the password must be logged out. The

“password logout” function os on the first level menu: press ↓ to choose “PW Logout” then press “Enter”.

1st level	2nd level	3rd level	4th level	5th level	6th level	Password	Description
OperationalStat ↓							
Operation ↓							
ManualOperation ↓							
Params & Display ↓							
Updating ↓							
PW Login ↓							
PW Logout						Service	Canceling the last access right obtained via password

Note: if no key is pressed within a settable period, the password is deactivated automatically.

Note: if a power supply drop occurs to the unit, the password will be automatically deactivated.

CHANGING THE PASSWORD

1st level	2nd level	3rd level	4th level	5th level	6th level	Pass- sword	Descrip- tion
Updating							
	Pas- sword						
		ServicePass- word				Service	3...8 cha- racters

- 1 Choose “Updating” on the first level menu and press “Enter”.
- 2 choose “Password” and press “Enter”: the unit asks to enter the new password;
- 3 press “Enter” to confirm;
- 4 the unit asks to enter the new password again to confirm;
- 5 press “Enter” to store the new password.

Attention: to perform interventions rapidly in case of necessity, it is recommended not to change the factory-set Service password.

BURNER ID NUMBER

The burner ID number corresponds to the **burner serial number**.

Note: in case of call to the Service Center, always tell the burner type and serial number.

- 1 Press “ Esc “ twice: the first level menu will be shown
- 2 by means of ↓, ↑, choose “Operation”;
- 3 press “Enter” to go to the second level and choose “BurnerID”;
- 4 press “Enter” to see the data.

1st level	2nd level	3rd level	4th level	5th level	6th level	Password	Description
OperationalStat							
	BurnerID					User	Identification of burner

the product ID number is an OEM parameter, entered by the burner manufacturer and it can not be changed; it can be made of minimum 4 characters and maximum 15.

To go back to the main page, press “Esc”  until the first level menu is reached, then press the “right arrow” , to choose the first row, then press “Enter”  twice.

BURNER STARTUP/SHUTDOWN BY MEANS OF THE THERMOSTATIC SERIES

The burner shuts down properly when the 1 and 4 terminals of the thermostatic series (X5-03.1 and X5-03.4 - terminals 3 and 4 of the burner terminal block) open. In this way, before shutdown, the burner drives to the minimum load, then the fuel valve will close. The post-purging phase will be performed if set. By re-closing the thermostatic series, the burner will startup again.

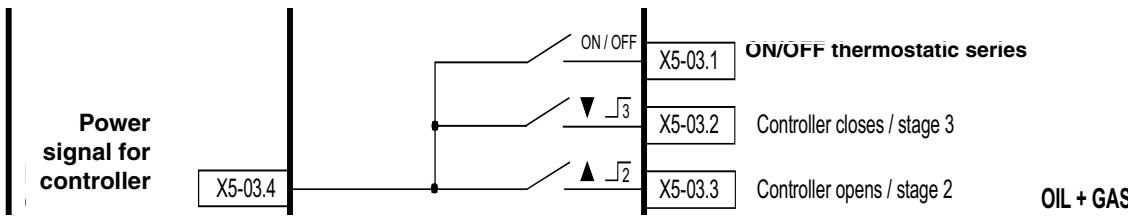

In the plant the safety thermostat is provided as well. If this thermostat switches (terminals X3-04.1 e X3-04.2 corresponding to terminals 318 and 319 of the burner supply terminal block - see below), the system will lead to an immediate burner lockout.

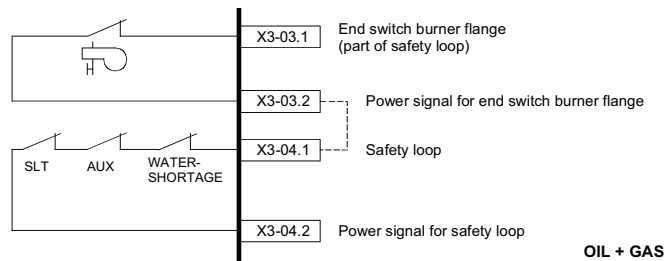

- SLT: safety loop thermostat
- AUX: auxiliary contact
- Water Shortage: water flow switch



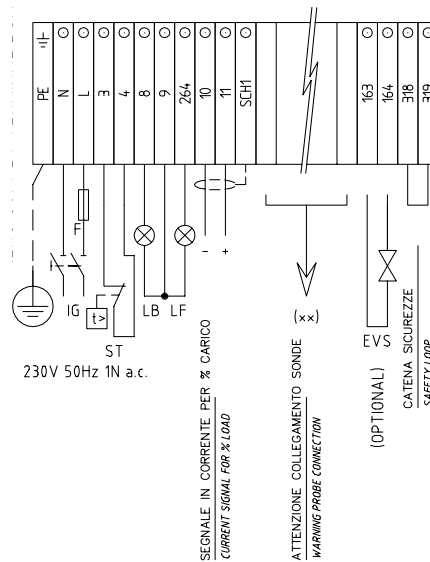

In case of burner designed with automatic pull-out system from the generator, the burner flange end switch is connected to terminals X3-03.1 e X3-03.2. If the contact opens, the burner automatically shuts down.

Burner supply terminal block:



The maximum number of emergency shutdowns is 16. When this number is reached a lockout will occur. AZL will show the message: "Open safety loop".



This number can be changed and set to a value between 1 and 16, following the next procedure:

1st level	2nd level	3rd level	4th level	5th level	Range	Default	Description
Params & Display							Menu level for making the parameter settings
	BurnerControl						Setting the burner control parameters
		Configuration					
			RepetitCounter				It sets the maximum number of possible repetitions
				SafetyLoop	1 - 16	16	

ADDRESSING THE ACTUATORS

The addressing assigns to each actuator its proper function. The addressing is factory set by the burner manufacturer.

If an actuator must be replaced, it is necessary to address it, otherwise the system will not work. The parameter that sets the actuator function is protected by the Service level password. Remember to check that the jumper "Bus termination" of the last actuator on the CAN bus is set to "On", before starting addressing.

1st level	2nd level	3rd level	4th level	5th level	6th level	Password	Description
Params & Display							
	Actuators						
		Addressing					Addressing unaddressed actuators
			1. AirActuator 2. GasActuat (Oil) 3. OilActuator 4. AuxActuator 1 5. AuxActuator 2 6. AuxActuator 3			Service	

To address an actuator, choose the corresponding actuator and follow the instructions on display:

When the actuator green LED flashes, it means that one of the following function is set according to the number of blinks:

Blinks	Actuator function
1 blink	air damper actuator
2 blinks	gas butterfly valve actuator
3 blinks	oil pressure governor actuator
4 blinks	auxiliary actuator
5 blinks	auxiliary actuator
6 blinks	auxiliary actuator

 **CAUTION:** it is recommended not to adjust the actuators. Anyway, never press the actuator red button, otherwise the fundamental parameters, necessary for the burner operation, will be cancelled. The burner will therefore continuously lock out.

In case P1 was accidentally pressed for a long time, it will be necessary to perform a new addressing of the actuator.

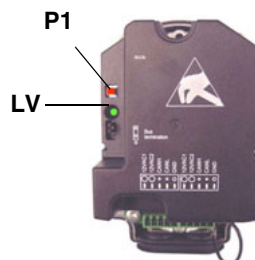





Note: when the actuator LV green LED is always lit, it means that the actuator has not been addressed yet or it has been reset and needs to be addressed again.

STANDARDIZATION OF THE MOTOR SPEED

Motor standardization (speed acquisition) allows the LMV unit to control the motor rounds at the maximum frequency signal coming from the VSD. A temporary standardization is factory set only for test purpose. The definite standardization must be performed on site by the Service Center, before the plant test.

To perform standardization, the burner must be in stand-by mode, not in lockout stage. The Safety loop must be closed (X3-04).

1st level	2nd level	3rd level	4th level	5th level	Range	Description
Params & Display						Menu level for making the parameter settings
	VSD Module					Settings for the VSD module
		Configuration				
			Speed			
				Standardization	deactivated/activated	Standardization process for fan speed





By activating the standardization, without starting the burner up, the air actuator drives to its maximum opening. The fan motor starts and the VSD drives the motor to its maximum speed. The speed sensor, mounted on the motor, detects the rpm value. LMV stores the data and the motor stops.

Attention: do not enter manually the rpm value of the motor data plate on parameter "StandardizedSp".





ATTENTION: the power cable that connects VSD to motor must be screened.

SETTING THE ACTUATOR SPEED

LMV sees VSD as an actuator, that's why the speed ramp up and the stop times must not be higher than the actuator stroke time. If it is necessary to increase the VSD times, change the actuator stroke time also, according to the next procedure. By following the next table, set both parameter "OperatRampMod" and "TimeNoFlame" to set the ramp up/stop times for the VSD and the actuator opening speed (from 0° to 90°).

1st level	2nd level	3rd level	4th level	Password	Range	Default	Description
Params & Display							Menu level for making the parameter settings
	RatioControl						Parameter settings for fuel/ air ratio control
		Times					
			OperatRampMod	Service	10...60 s	40s	Duration operating ramp fuel / air ratio control modulating operation
			TimeNoFlame	Service	10...120 s	40s	Duration ramp in pre-purge and ignition position

SETTING THE LOAD CONTROLLER

1st level	2nd level	3rd level	4th level	5th level	6th level	Password	Description
Params & Display							Menu level for making the parameter settings
	LoadController						Settings for the internal load controller
		Configuration					General configuration of the load controller
			LC_OptgMode			User	Operating mode with load controller
				ExtLC X5-03 Int LC Int LC Bus Int LC X62 Ext LC X62 Ext LC Bus		User	

It is possible to choose the type of load controller: the LMV internal controller, an external one, the LMV internal load controller but with an external control etc..:

ExtLC X5-03 = three-point external controller (X5-03 terminals)

Int LC = internal controller (LMV5x)

Int LC Bus = internal controller and supervision via bus connection

Int LC X62 = internal controller (LMV), but set point is externally controlled by means of a voltage/current signal on X62 terminals

Ext LC X62 = external controller, the burner output is controlled by means of a voltage/current signal on X62 terminals

Ext LC Bus = external controller, the burner output is controlled via bus

- **Wiring diagram for three-point external load controller on X05-3 terminals**

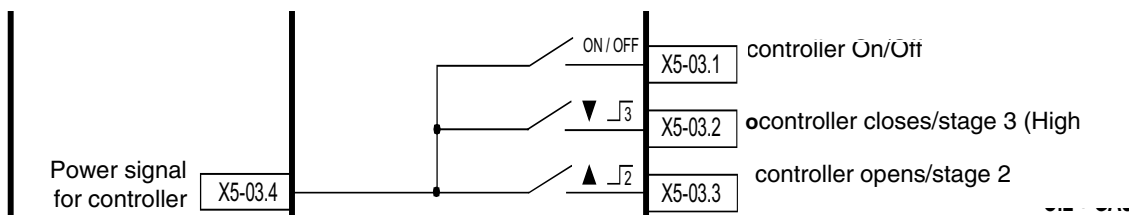

X5-03.4 = power signal for controller

X5-03.1 = controller On/Off

X5-03.2 = controller closes/stage 3 (High flame)

X5-03.3 = controller opens/stage 2 (Low flame)

● **Wiring diagram for external load controller by voltage/current signal on X62 terminals**

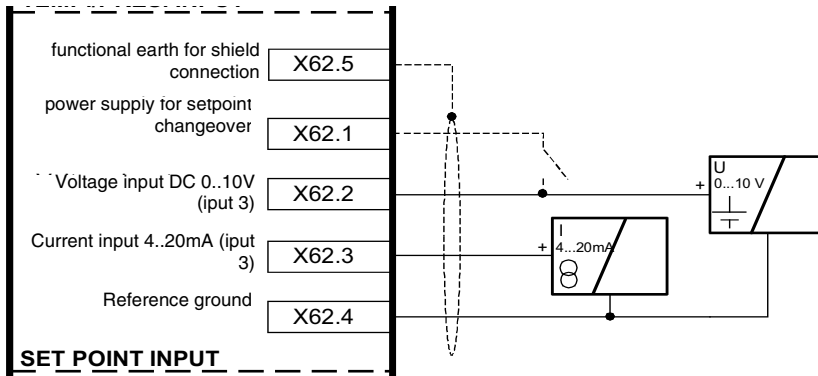

- X62.5 = functional earth for shield connection
- X62.1 = power supply for setpoint changeover
- X62.2 = Voltage input DC 0..10V (input 3)
- X62.3 = Current input 4..20mA (input 3)
- X62.4 = Reference ground

● **Wiring diagram for external load controller by voltage/current signal on burner terminal block**







If the set-point is to be changed externally or load is to be controlled externally by means of a signal on terminals X62, choose the signal as follows:

1st level	2nd level	3rd level	4th level	5th level	6th level	Password	Description
Params & Display							Menu level for making the parameter settings
	LoadController						Settings for the internal load controller
		Configuration					General configuration of the load controller
			Ext Inp X62 U/I			Service	Configuration of external input X62: input signal on X62 can change setpoint or control the load
				4...20 mA 2...10 V 0...10 V 0...20 mA			

SETTING THE TEMPERATURE OR PRESSURE PROBE

If the LMV5x internal load controlled is used, a temperature or pressure probe can be connected pt terminal X60 or X61. In this case, it is necessary to set the kind of probe and its operating range.

1st level	2nd level	3rd level	4th level	5th level	6th level	Pas- sword	Descrip- tion
Params & Display							Menu level for making the para- meter set- tings
	LoadCon- troller						Settings for the internal load con- troller
		Configura- tion					General configura- tion of the load con- troller
			Sensor Select				Select actual value input
						Service	Pt100 Pt1000 Ni1000 Temp sen- sor Press sen- sor Pt100Pt10 00 Pt100Ni10 00 NoSen- sor

Note: if the external load controller is set, it uses its own independent probe, not connected to terminals X60. If a boiler second probe is to be connected to terminals (1000ohm only), internal functions TL_ThreshOff and DiffIntervTL_SD_On are activated automatically (see next paragraph "Setting TL_ThreshOff and TL_SD_On"). These functions enable the settable threshold for the immediate shutdown, if value set on TL_ThreshOff is exceeded. The automatic restart is performed for values lower than the one set on TL_SD_On. On display, values detected by temperature/pressure probe are shown contemporarily.

Possible settings are:

Probe	Description
Pt100	Only modulation
Pt1000	Modulation and temperature limiter active TL_thresh.Off
Ni1000	Modulation and temperature limiter active TL_thresh.Off
Temperature probe	Only modulation
Pressure probe	Only modulation
Pt100 + Pt1000	Modulation + temperature limiter TL_thresh.Off
Pt100 + Ni1000	Modulation + temperature limiter TL_thresh.Off
No probe connected	Only External modulation

Connecting 100 ohm / 1000 ohm temperature probes directly to LMV terminals

Connecting 0...10V / 4...20 mA / 0...20 mA pressure probes directly to LMV terminals

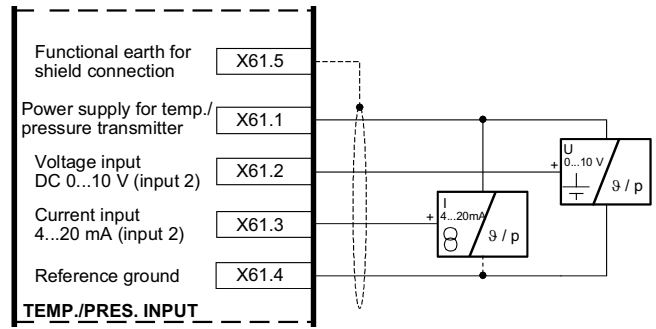
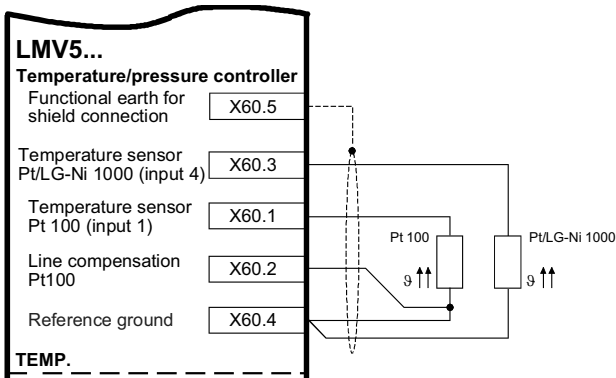

Temperature probes on burner control panel

Pressure probes on burner control panel

Terminals		Description
LMV	Burner	
X60.5	SCH	Functional earth for shield connection
X60.3	13C	Temperature probe 1000 Ω
X60.1	13D	Temperature probe 100 Ω
X60.2	13B	Compensation line
X60.4	12A	Reference ground

Terminals		Description
LMV	Burner	
X61.5	SCH	Probe cable screen
X61.1	13A	Power supply for temp./pressure probe
X61.2	13	Voltage input (0..10V)
X61.3	13G	Current input (0/4..20mA)
X61.4	12	Reference ground



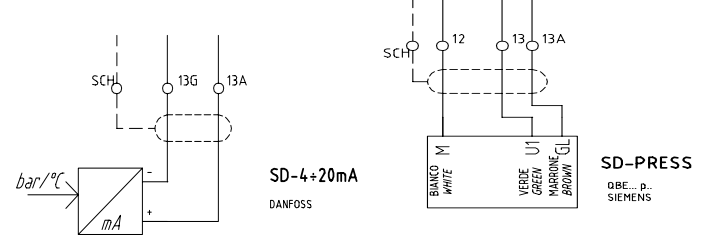
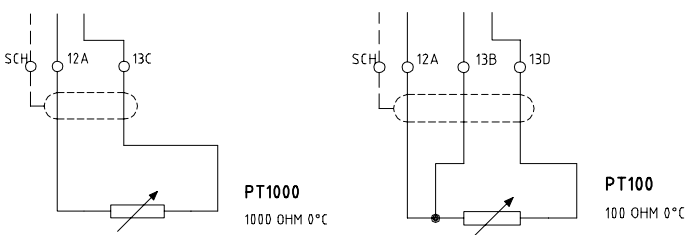

Connecting 100 ohm / 1000 ohm temperature sensors to burner terminals

Connecting 0...10V / 4...20 mA / 0...20 mA pressure sensors to burner terminals







Note: Siemens QBE2...P pressure probes send a 0-10 Volt output signal, while Danfoss MBS3200... pressure probes send a 4-20 mA output signal.

If a pressure probe is used, set its output signal type sent to X61 input, proceeding as follows:

1st level	2nd level	3rd level	4th level	5th level	6th level	Pas- sword	Descrip- tion
Params & Display							Menu level for making the para- meter set- tings
	LoadCon- troller						Settings for the internal load con- troller
		Configura- tion					General configura- tion of the load con- troller
			Ext Inp X61 U/ I				Configura- tion of external input X61Config urazione ingresso X61
						Service	4...20 mA 2...10 V 0...10 V 0...20 mA

Once the pressure sensor signal type is set, the sensor range must be set as well, proceeding as follows:

1st level	2nd level	3rd level	4th level	5th level	6th level	Pas- sword	Description
Params & Display							Menu level for making the parame- ter settings
	LoadCon- troller						Settings for the inter- nal load controller
		Configura- tion					General configura- tion of the load con- troller
			MRange Press-Sens				End of pressure measuring range for input X61
						Service	0...99.9 ba

Example: if a max 10bar Siemens sensor is used, the voltage output signal will be 0Volt at 0bar, while the 10Volt signal will correspond to its maximum pressure 10bar. If the sensore is replaced with a max 16bar one, the 0V output signal will correspond to 0bar, while the 10V output signal will correspond to 16bar pressure: the parameter "MRange Press-Sens" has to be set at 16bar.

SETTING FUNCTIONS “TL_ThreshOff” AND “TL_SD_On”

Note: this function is available if a Ni1000 or Pt 1000 temperature sensor is connected to X60.3 and X60.4 terminals.

- **TL_ThreshOff:** it turns the burner off if temperature exceeds the set value.
- **TL_SD_On:** it automatically restart the burner up of temperature is lower than the set value.

ATTENTION: basically, these parameters provide a function similar to the safety thermostat one, but can not replace it. The boiler must **always** operate with its safety thermostat connected properly.

ATTENTION: the parameter TL_ThreshOff for the immediate shutdown, must always be set to a value higher than the SD_ModOff threshold for the normal shutdown (see chapter Setting functions “TL_ThreshOff” and “SD_ModOn”).

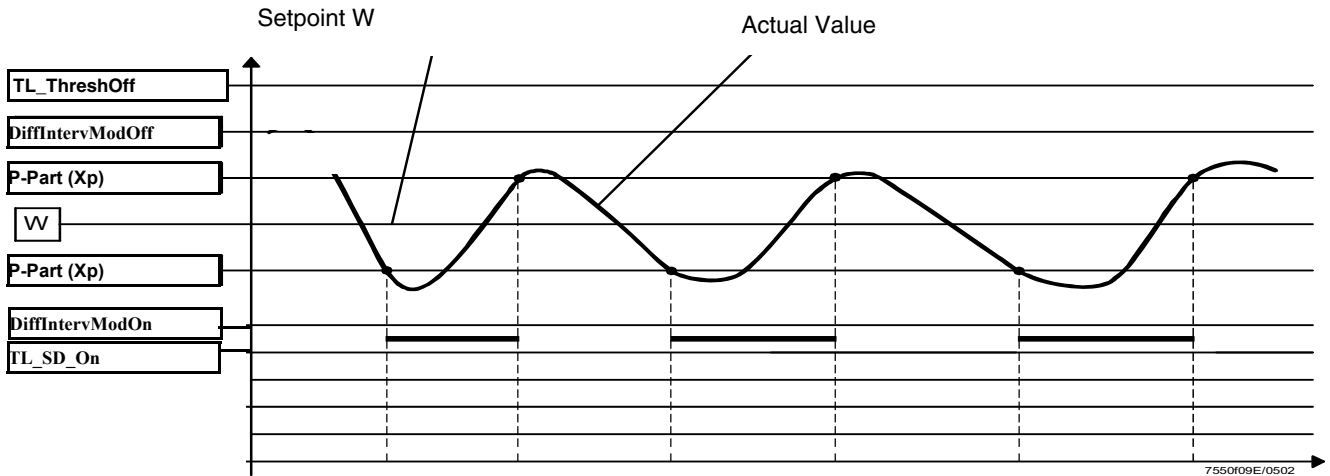

1st level	2nd level	3rd level	4th level	Range	Pas- sword	Default	Descrip- tion
Params & Display							Menu level for making the parameter settings
↳	LoadCon- troller						Settings for the internal load controller
	↳	TempLimiter					Settings for the temperature limiter function
		↳	TL_ThreshOff	0...2000 °C	Service	95°C	Temperature limiter OFF threshold, in °C
		↳	TL_SD_On	-50...0% TL_Thres h_Off	Service	- 5%	Temperature limiter switching differential ON

SETTING THE TEMPERATURE SET-POINT VALUE

Note: the set-point parameter is user settable.

To set the temperature set-point value, that is the generator operating temperature; proceed as follows. From the main page, enter the main menu by pressing the ESC key twice:

OperationalStat
Operation
ManualOperation
Params & Display.

by means of the arrow keys, select "Params&Display", press ENTER: the system will ask you to enter the proper password

Access w-out PW
Access Serv
Accesso con OEMAccess
OEM
Accesso con LSAccess LS

by means of the arrow keys, select "Access w-out pass" (access without password - user level), confirm by pressing ENTER. The other levels require password reserved to the Technical Service, to the Manufacturer, etc. The menu accessed without password is the following:

BurnerControl
RatioControl
O2Contr/Guard
LoadController

Choose "LoadController" and press ENTER: the following menu is shown:

ControllerParam
Configuration
Adaption
SW Version

Choose "ControllerParam" and press ENTER: the following menu is displayed:

ContrlParamList
MinActuatorStep
SW_FilterTmeCon
SetPointW1

Choose "**SetPointW1**" and press ENTER:

SetPointW1
Curr: 90°
New: 90°

Curr: it shows the current set-point; use the arrows keys to change it.

NOTE: the available range depends on the probe used; the measure unit of the detected data and its relevant limits are set by "Service" level parameters. Once the new set-point is set, confirm by pressing ENTER, otherwise exit without changings by pressing ESC. Press ESC to exit the set-point programming mode, afeter pressing ENTER to confirm the data prompted.

Once the temperature set-point W1 is stored, set the Switch-on (SDon) and the Switch-off (SDoff) point:

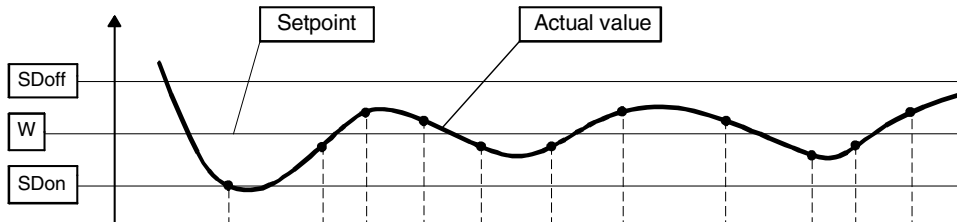

To set these values, choose the item SD_ModOn (SDOn), by scrolling down the “Load controller” menu with the arrow keys and press ENTER:

```
SetPointW1
SetPointW2
SD_ModOn
SD_ModOff
```

the display will show:

```
SD_ModOn
Curr: 1.0%
New: 1.0%
```

The default value for this parameter is 1% that is, the burner will light again at a temperature 1% lower than the set-point. Change value, if needed, by means of the arrow keys; press ENTER to confirm and the press ESC to exit. Press only ESC to exit without changing.

Now choose SD_ModOff always scrolling down the Load Controller menu, by means of the arrow keys, and press ENTER.

```
SetPointW1
SetPointW2
SD_ModOn
SD_ModOff
```

the display will show:

```
SD_ModOff
Curr: 10.0%
New: 10.0%
```

The default value for this parameter is 10% that is, the burner will turn off at a temperature 1% higher than the set-point.

Press the ENTER to confirm, the press ESC to exit. Otherwise press ESC to exit without changing data.

Press the ESC key until the following menu is shown:

```
BurnerControl
RatioControl
O2Contr/Guard
LoadController
```

IGNITION POINT

Gas burner with “G” type direct ignition, with no ignitor

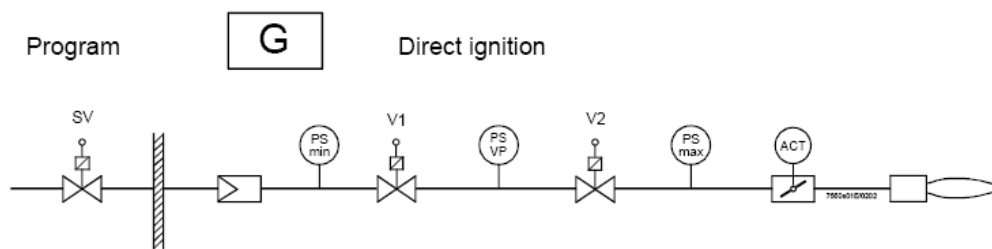

SV = Safety valve

V1 = Valve 1

V2 = Valve 2 & gas governor

ACT = Gas actuator

The ignition point is independent from the other curvepoints of the air/fuel ratio curve.

As far as dual fuel burners, the ignition point set for the gas operation does not depend on the one set for the oil operation.

The burner is provided with a factory-set ignition point, to make easier the first ignition procedure by the Service Centre.

The air actuator at the ignition point, is factory set at a 6°/7° opening, while the gas actuator is set at 12°/15°. In case of burner provided with VSD, it is suggested to set ignition at 100% VSD frequency.

The primary target for the regulation is to set the actual operating pressure for the gas governor (V2 in the scheme) at the maximum flow rate. All the adjustments depend on this pressure value, the ignition point adjustment as well.

TO change the actuator positions on the ignition point, proceed as follows.

Changing the actuator position on the gas ignition points

1st level	2nd level	3rd level	4th level	5th level	6th level	Pas- sword	Descrip- tion
Params & Display							Menu level for making the parameter settings
↳	RatioControl						
	↳	GasSettings					
		↳	Special Positions				
			↳	IgnitionPos			
				↳	IgnitionPosGas	Service	
				↳	IgnitionPosAir	Service	
				↳	IgnitionPosAux 1	Service	
				↳	IgnitionPosAux 2	Service	
				↳	IgnitionPosAux 3	Service	
				↳	IgnitionPosVSD	Service	

Example:

IgnitionPosGas: 12°; IgnitionPosAir: 6,7°; IgnitionPosVSD: 100% frequency



CAUTION! If no flame is detected at ignition stage, proceed as follows:

- check the gas pipeline was properly bled
- increase setp by step (max 2° per step) the gas actuator opening at ignition position
- it is recommended not to exceed 20° opening.

Other reason for ignition missing can be due to the following causes:

- electrodes ceramic insulator broken
- electrode ignition cable disconnection, while removing/mounting the blast tube
- ignition cable damaged
- faulty ignition transformer
- faulty fuel valve
- excess of combustion air at the ignition point (i.e., in case of very high depressure in the combustion chamber)

If flame does not appera within the safety time "SafetyTme1Gas/Oil", or it appears but it is not detected by the flame detector, the burner locks out and the following message is displayed:

"NO FLAME AT END OF SAFETY TIME"

alternatively code number **C:25** and diagnostic number **D** appear:

C: 25 D:----

If burner does not start up the message will be:

"FAULT POSITIONING ACTUATOR"

alternatively code number **C:15**, and diagnostic code **D** appear:

C: 15 D:----

it means that there is a faulty actuator and its number is represented by the diagnostic code **D**.

- C:15 D 01** = Air actuator position not reached
- C:15 D 02** = Fuel actuator position not reached
- C:15 D 04** = Aux1 actuator position not reached
- C:15 D 08** = Aux2 actuator position not reached
- C:15 D 10** = Fan speed not reached
- C:15 D 20** = Aux3 actuator position not reached

ATTENTION: in these cases the actuator must be replaced and addressed (see paragraph "Addressing the actuators").

Gas burners with pilot "Gp2"

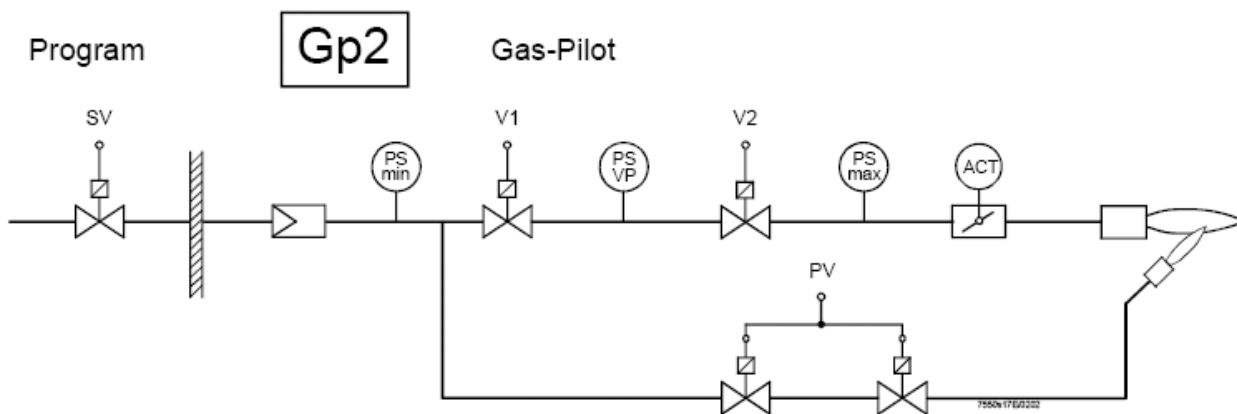

- SV = Safety valve
- V1 = Valve 1
- V2 = Valve 2 & gas governor
- ACT = Gas actuator
- PV = Pilot Valve

The burner is provided with factory-set ignition point. The pilot (PV) gas valves are adjusted completely open and the pilot pressure governor (PV) is set to values that allow easy operation for the Service Centre at first ignition.

If the pilot flame does not appear within the first safety time, The V1 and V2 main valves will not open and the “Flame lockout” will occur.

The gas actuator (ACT) is not involved during pilot ignition, anyway it is set on average values to easily pass from pilot flame to main gas valves low flame. The air actuator is set on average value as well, in order to make the Service Centre perform the first ignition easily.

If factory setting is not sufficient, it is possible to change both the governor output pressure of the pilot valve (PV) and the air actuator angle at ignition point, following the procedure on previous paragraph.

ADJUSTING THE AIR/FUEL RATIO CURVES

	Attention: when burners are provided with VSD , before setting the air/fuel ratio curves, the Standardization of the motor speed must be performed (see chapter “Standardization”).
---	--

- 1 From the main page

Setpoint	80°C
Act.value	78°C
Standby	12

enter the main menu by pressing the ESC key twice: the display will show

OperationalStat
Operation
ManualOperation
Params & Display.

- 2 by means of the arrow keys, select “Params&Display”, press ENTER: the system will ask you to enter the proper password, if it has not been entered yet:

Access w-out PW
Access Serv
Accesso con OEMAccess
OEM
Accesso con LSAccess LS

- 3 by means of the arrow keys, select “AccessService” (service level), confirm by pressing ENTER.
- 4 insert the Service Level password that is “9876” (default value);
- 5 To insert a character (number or letter) press the arrow keys until the desired character is reached, then press ENTER to confirm and get the next character (the character entered will not be displayed once confirmed by ENTER).



- 6 Repeat the procedure until the password is completed
- 7 Confirm the password by pressing ENTER again
- 8 The display will show

BurnerControl
RatioControl
O2Contr/Guard
LoadController

DEAFUL SETTINGS

To make the startup operation easier for the Service Centre, two curvepoints are factory set (default settings):

- 1 the first point (**P1**) is temporarily named "10% load": the air and gas actuators opening are set on minimum values;
- 2 for safety reasons, at the second point (**P2**) the air and gas actuators opening impostati are set on **P1** same minimum values, even if **P2** is temporarily named "100% load".

Note: points P1 and P2, are temporarily mentioned as 10% and 100% load, independently from the actual load. The operator can name the load on each point, without respecting the actual load value in that point. LMVx will order those points automatically according to the load values set by the operator.

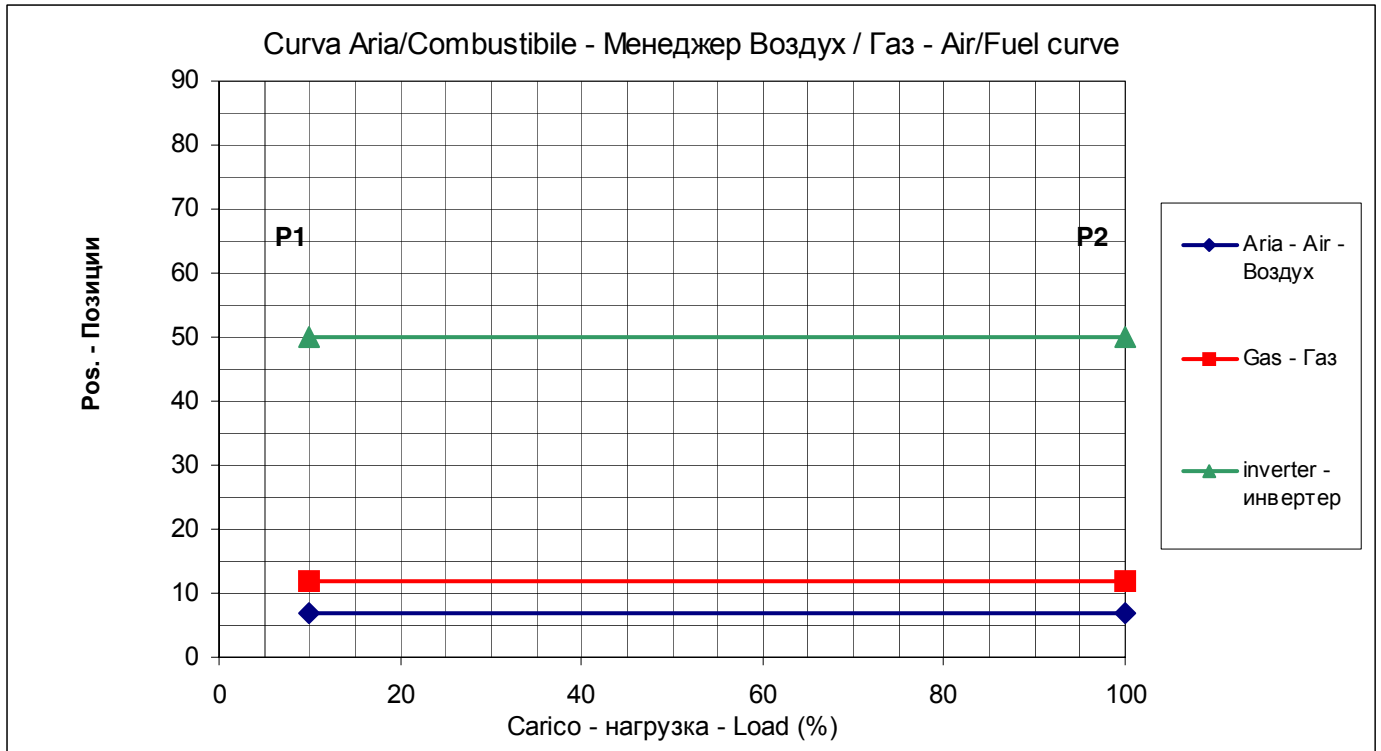

Fig. 1 - Diagram of default curve

With this setting, by closing the thermostat series, the burner drives to minimum load position **P1**, after ignition. Then it drives to the maximum load position **P2** without increasing the output as both the points are set with actuators minimum opening.



Setting the maximum load point for the maximum output

To set the maximum load point **P2** according to the maximum output, proceed as follows:

1 from menu

BurnerControl
RatioControl
O2Contr/Guard
LoadController

follow the procedure shown on the next table, using the designated keys:

1st level	2nd level	3rd level	4th level	Password	Description
Params & Display				Service	
	RatioControl				Parameter settings for fuel/ air ratio control
		Gas settings			Parameter settings for firing on gas
			CurveParams		At this level, the air/fuel ratio during operation is to be set.

2 by means of the arrow keys, select "CurveParams" and confirm by pressing ENTER: the display will show

Point		10
\	Fuel	6.7
	Air	12
Man	VSD	50

Wait until symbol "\ " stops twisting.

Press Enter to see Point1.



Point	Load	10
:1	Fuel	12
O2	Air	6.7
	VSD	50

Press "right arrow"  to see Point2.



Point	Load	100
:2	Fuel	12
O2	Air	6.7
	VSD	50

Press Enter to change Point2.



Change
Delete

(Only for LMV52xx) Press Enter to change Point2.



Follow
Not follow

Press Enter on "Follow"



Point	Load	100
:2	Fuel	12
O2	Air	6.7
	Aux1	xx
	VSD	50

Now it is possible to change Point2 with the next procedure

Checking continuously the excess of air by means of the combustion analyser, increase by few degrees* (see Note below) the air damper opening and the VSD if provided.

Then increase by few degrees* (see Note below) the gas butterfly valve as well (or the fuel actuator). Go on step by step, until the butterfly valve complete opening is reached (actuator at 90° - see diagram).

The target is to reach the gas butterfly valve maximum with a sufficient excess of air. While progressively increasing the actuator positions, besides increasing the air quantity the fuel rate must be controlled by means of the valve pressure governor, in order to not exceed the requested maximum flow rate.

Once the gas butterfly valve maximum opening is reached, adjust the fuel **rate** only acting on the gas valve pressure governor (or on the oil pressure governor incase of oil).

***Note:** as for “increasing by few degrees” it means that the increasing must be performed in order to avoid great excess of air or loss of air.

Therefore the increasing operation must be performed always checking the flue gas analysis by means of the combustion analyser. It is recommended to make increasing while mantaining O₂ % between max 7,5% and min 3%.

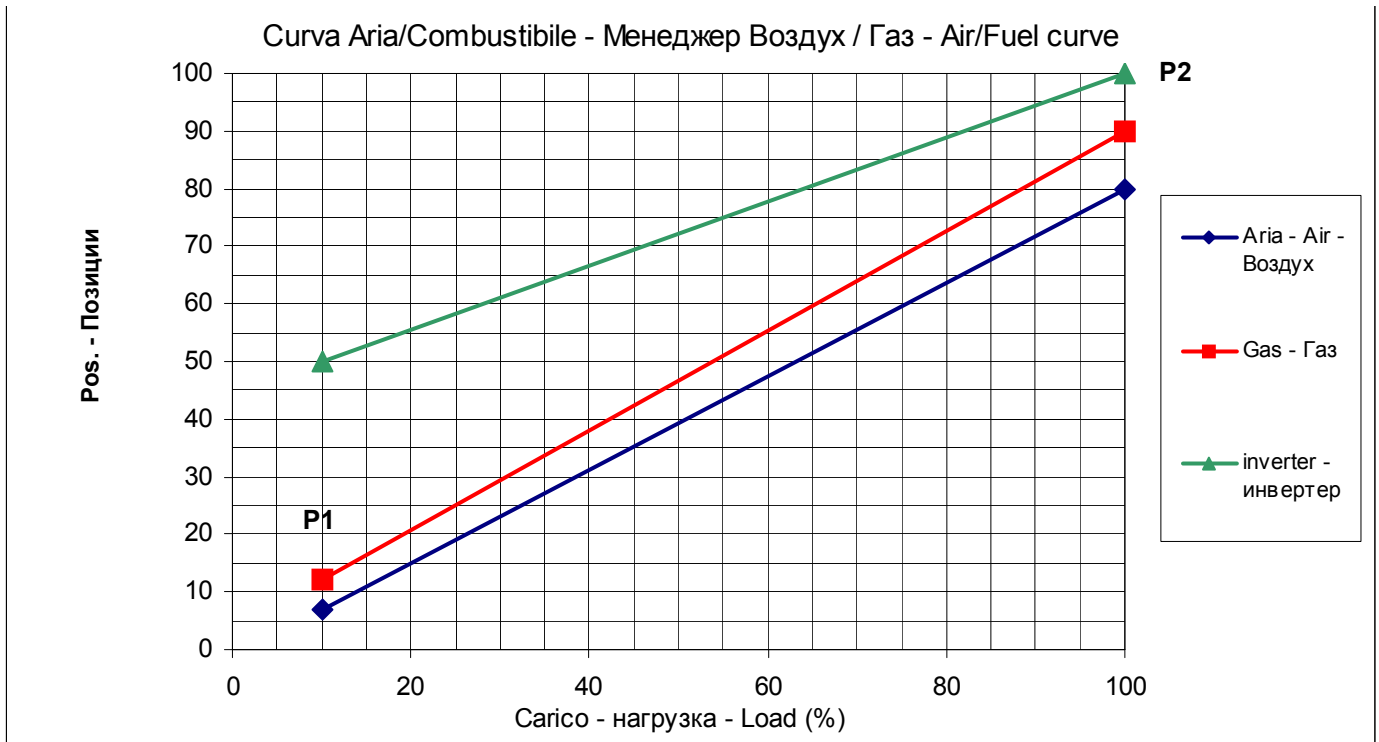

Once the fuel rate is set by means of the valve group pressure regulator, checking continuously the excess of air by means of the combustion analyser, set the air excess by means of the air actuator and/or VSD. At the end, store the point 2 following the below procedure:

Point	Load	100
:2	Fuel	12
O2	Air	6.7
	VSD	50

To choose the actuator to set, press the “left arrow” and choose Air or VSD





Point	Load	100
:2	Fuel	12
O2	Load	6.7
	VSD	50

Press Enter to access the Air actuator value to be set.







Point	Load	100
:2	Fuel	12

Press keys to change the value.

O2 Air Press Enter  to confirm the value and go back to Air actuator. (Do not exit by pressing Esc  from the values column because data will not be stored)





Point	Load	100
:2	Fuel	12
O2	Air	9.5
	VSD	50

Press arrows   to select another actuator to be set, for example, press   to choose **Fuel**

Point	Load	100
:2	Fuel	12
O2	Air	9.5
	VSD	50

Press Enter  to access the value to be changed for Fuel actuator.



Point	Load	100
:2	Fuel	12
O2	Air	9.5
	VSD	50

Press keys    to change the value. Press Enter  to confirm the value and go back to Fuel actuator

Point	Load	100
:2	Fuel	15
O2	Air	9.5
	VSD	50

Checking parameters by means of the combustion analyser go on increasing the Air (and/or VSD if provided) and the Fuel actuators until the butterfly gas valve 90° position is reached.

Point	Load	100
:2	Fuel	90
O2	Air	85
	VSD	100

Press Enter  to confirm the value and go back to **Fuel**. **Do not press** Esc  from the values column otherwise data will not be stored.

Point	Load	100
:2	Fuel	90
O2	Air	85
	VSD	100

Once the gas butterfly valve maximum opening is reached, adjust the fuel rate by means of the gas valve pressure governor only (or by the oil pressure governor if oil burner is provided)..

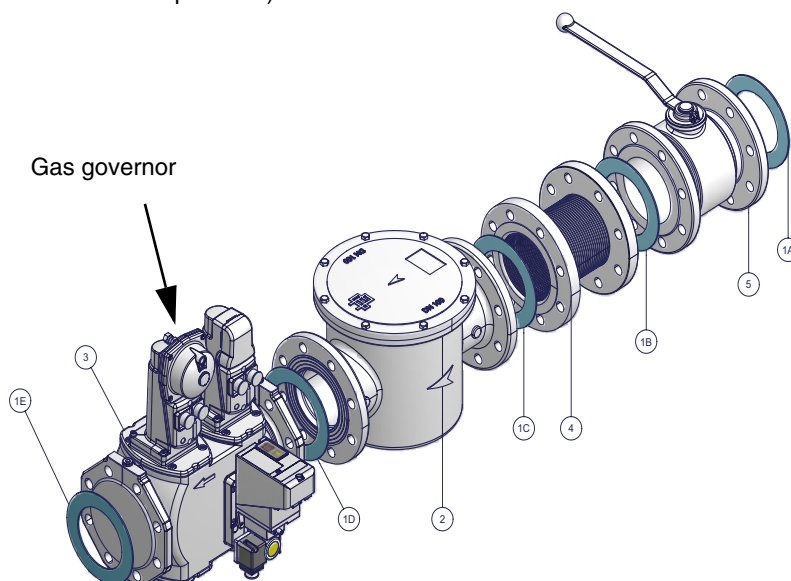

Once the fuel rate is set by the governor, adjust the excess of air by means of the Air actuator and/or VSD, always checking the combustion values.

Storing the curve point

Point	Load	
:2	Fuel	90
O2	Air	85
	VSD	100

From the actuator column, press  to store the point, the display will show:



Point	
Store	Enter
Cancel	ESC

Press Enter  to confirm the point

Do not exit by means of Esc  directly from the values column or data will not be stored.



Point	Load	
:2	Fuel	90
O2	Air	85
	VSD	100

Point2 is then stored.

Caution! For safety reasons, once the maximum load point P2 is set, never go down to the minimum load point P1, without having set the other intermediate points before (see next paragraph).

Caution! In case it is necessary to immediately shut the burner down while working at high flame and the maximum load point already set, shut the burner down by means of the main switch. When starting the burner up again, do not go from point P1 to point P2 without setting the intermediate points before.

Caution! In case it is necessary to immediately shut the burner down while working at high flame and the maximum load point is not already set observing the combustion parameters, decrease gas by means of the pressure governor as to drive the burner to a sufficient excess of air, the shut the burner down by the main switch. At next startup, start again with point P2 to the minimum load (factory-setting - see previous paragraph) and go on setting the curve points.

Setting a new point (P3)

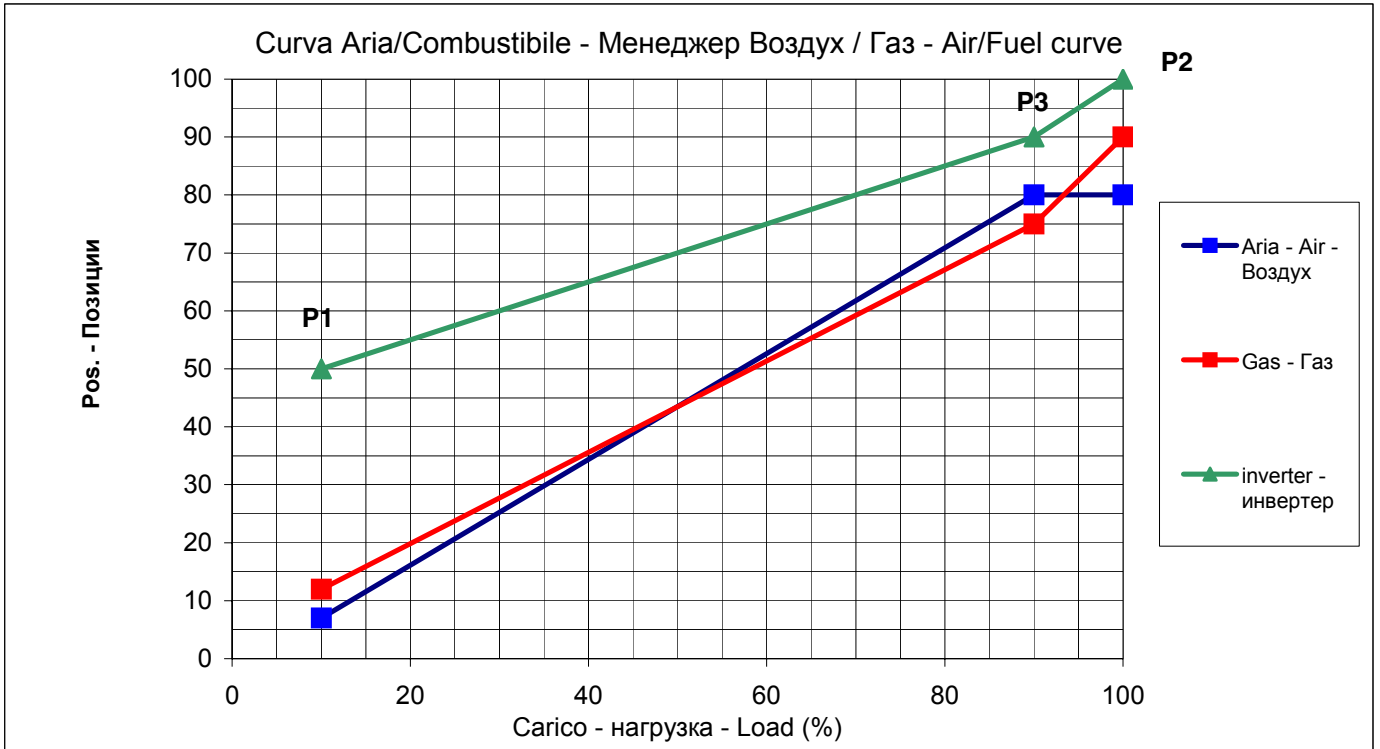

To store a new point, proceed as follows:

Point	Load	100
:2	Fuel	90
O2	Air	85
	VSD	100

From the last point saved (P2), press key , the following display will be shown to set the new point (P3).



Point	Load	xxxx
:3	Fuel	xxxx
O2	Air	xxxx
	VSD	xxxx

Press Enter to access the new point (P3) to be set: the new point will be shown with the same values of the previous point (P2).



Point	Load	100
:3	Fuel	90
O2	Air	85
	VSD	100

Press Enter to change the load on the new point P3.

Then by means of change its value.



Point	Load	90
:3	Fuel	90
O2	Air	85
	VSD	100

For example, if the load value at the new point (P3) should be 90 %, by means of it is possible to change the value.



Point	Load	90
:3	Fuel	90
O2	Air	85
	VSD	100

Premere Enter per confermare e tornare nella colonna dei servocomandi.

Point	Load	90
:3	Fuel	90
O2	Air	85
	VSD	100

To choose, for instance, the new actuator **Comb** to be set, use keys ↓↵↵↑

Point	Load	90
:3	Load	90
O2		85
	VSD	100

Press Enter ↵

Point	Load	90
:3	Fuel	Load
O2	Air	85
	VSD	100

Change values by means of ↓↵↵↑

Supponendo di voler ridurre il combustibile ad un certo valore, per esempio a 75°, utilizzare ↓↵↵↑

Point	Load	90
:3	Fuel	75
O2	Air	85
	VSD	100

Press Enter ↵ to confirm and go back to the actuator column, then choose the air actuator and change the values with the same procedure, to get the air excess values for that point. The P3 point is then set, positioned as shown:

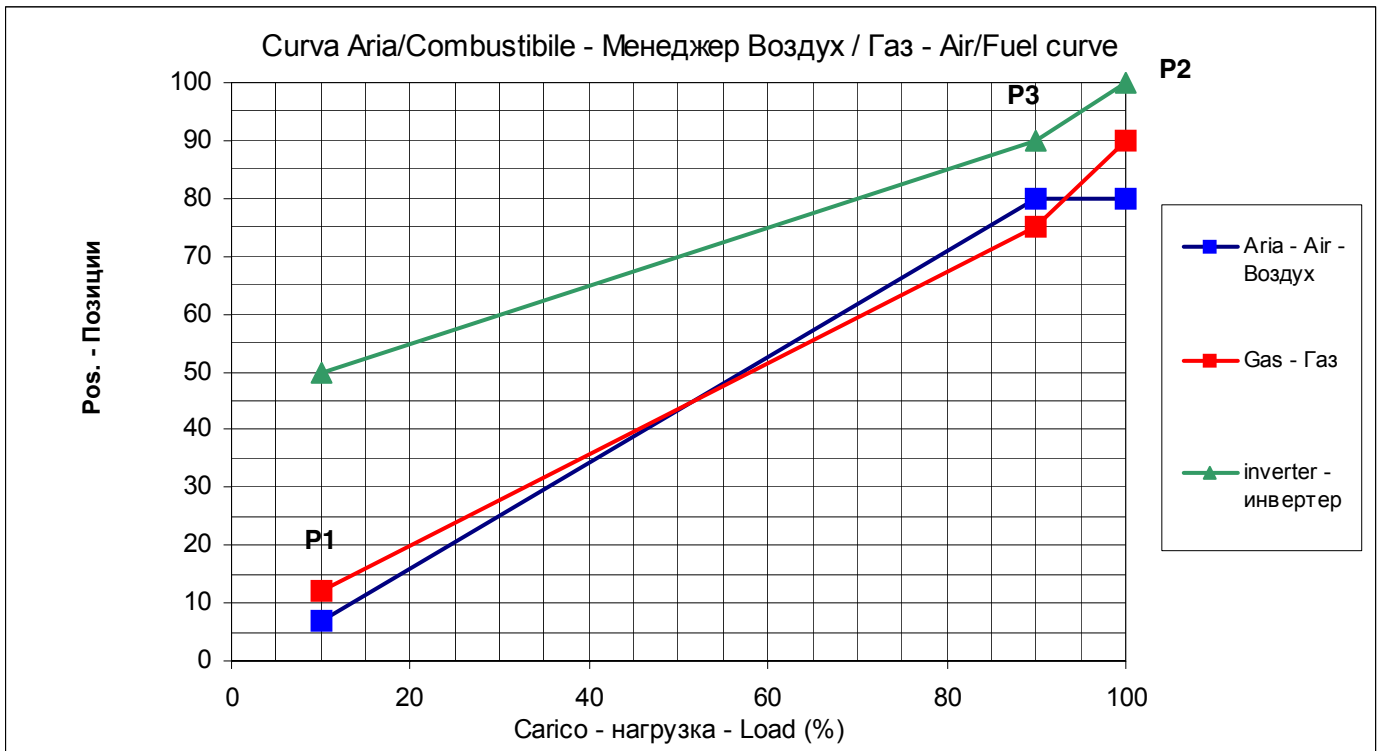



Point	Load	100
:2	Fuel	90
O2	Air	85
	VSD	100

At the end of procedure, store the new point by exiting the actuators column by pressing Esc .
To store the point, the display will show:



Store	Enter
Cancel	ESC

Press Enter  to confirm the point

Do not directly exit by pressing Esc  from the numeric column otherwise data will not be stored.

Once the point is stored, LMV will order the points automatically according to the load:

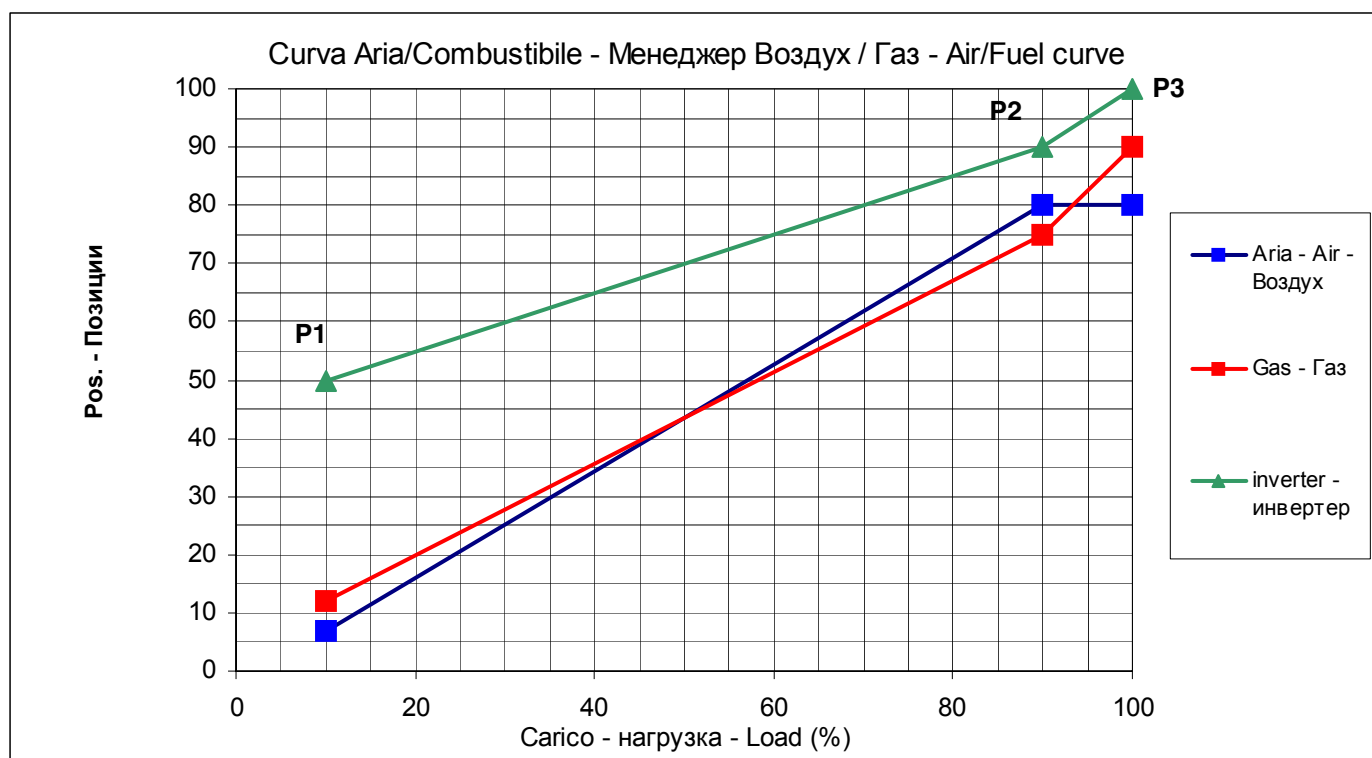

Go on setting the other points until the minimum load point is reached, as shown in the picture as example.
Maximum 15 points can be set, usually 8-10 points can be enough.

Example of air/fuel ratio curve:

Load %	Air	Gas	VSD
20	12	16.6	50
30	20	19.7	50
40	30	23.8	51
50	40	29.3	55
60	49.7	36.6	60
70	60.7	45	70
80	67.6	52.1	82.8
90	72.4	65	92.4
100	76.6	90	100

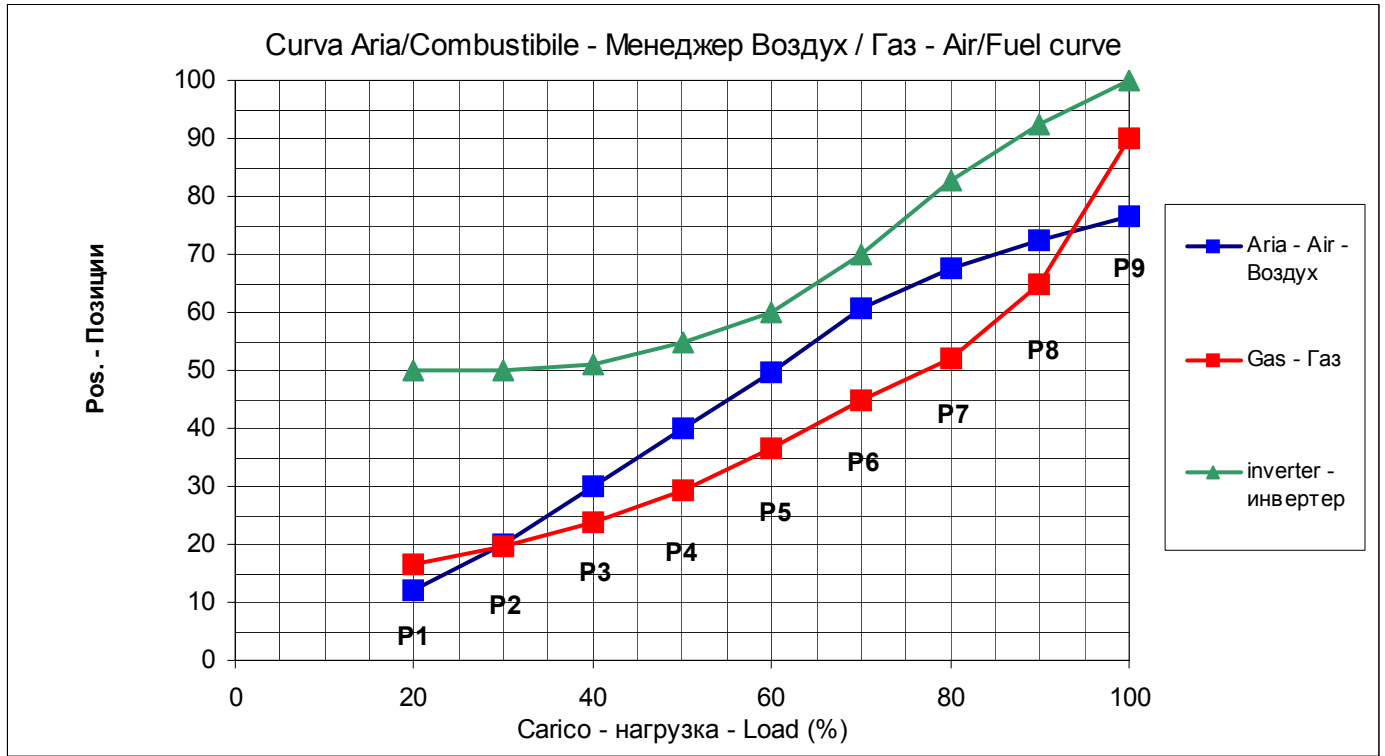

Note: in case of burners provided with VSD, it is recommended not to go below 50% the motor speed.

Cold start thermal shock (CSTP)

If there is a steam boiler or a boiler that must start up cold in the plant and to avoid thermal shocks a slow heating is required for the boiler by maintaining the burner at the minimum output, the automatic function "Cold start thermal shock" can be performed instead of the manual operation at minimum load.



The CSTP (Cold Start Thermal Schock) function can be enabled by the Technical service only (access by reserved password).

if this function is enabled, when the burner starts up the "Thermal shock protection activated" message will be shown.





If this function is not enabled, after startup, the burner will rapidly increase the load according to the requested value.

Note: by enabling the manual operation (this function can be set at user level also -see chapter "manual operation") the CSTP function is momentarily excluded, when enabling the automatic operation again, the CSTP function (previously set at Service level) will be enabled as well.

The CSTP function is a Service level parameter, to enable this function proceed as follows:

1st level	2nd level	3rd level	4th level	Range	Password	Default	Description
Params & Display							Menu level for making the parameter settings
	LoadController						Settings for the internal load controller
		ColdStart					Settings for the cold start (thermal shock protection)
			ColdStartOn	deactivated/activated	Service	deactivated/	Cold start thermal shock protection, activate / deactivate

The parameter **ColdStartOn** deactivates or activates the Cold start protection function, the other parameters are factory set and can be changed following the next programming rows (see diagram)

			ThresholdOn	0...100%Wcurrent	Service	20%	Cold start thermal shock protection activation level referred to the current setpoint (Wcurrent)
			StageLoad	0..100%	Service	15%	Cold start thermal shock protection load step (modulating)
			StageSetp_Mod	1...100% Wcurrent	Service	5%	Cold start thermal shock protection setpoint step (modulating) referred to the current setpoint (Wcurrent)
			Stage-Setp_Stage	1...100% Wcurrent	Service	5%	Cold start thermal shock protection setpoint step (multi-stage) referred to the current setpoint (Wcurrent)
			MaxTme-Mod	1...63 min	Service	3 min	Cold start thermal shock protection, max. time per step (modulating)

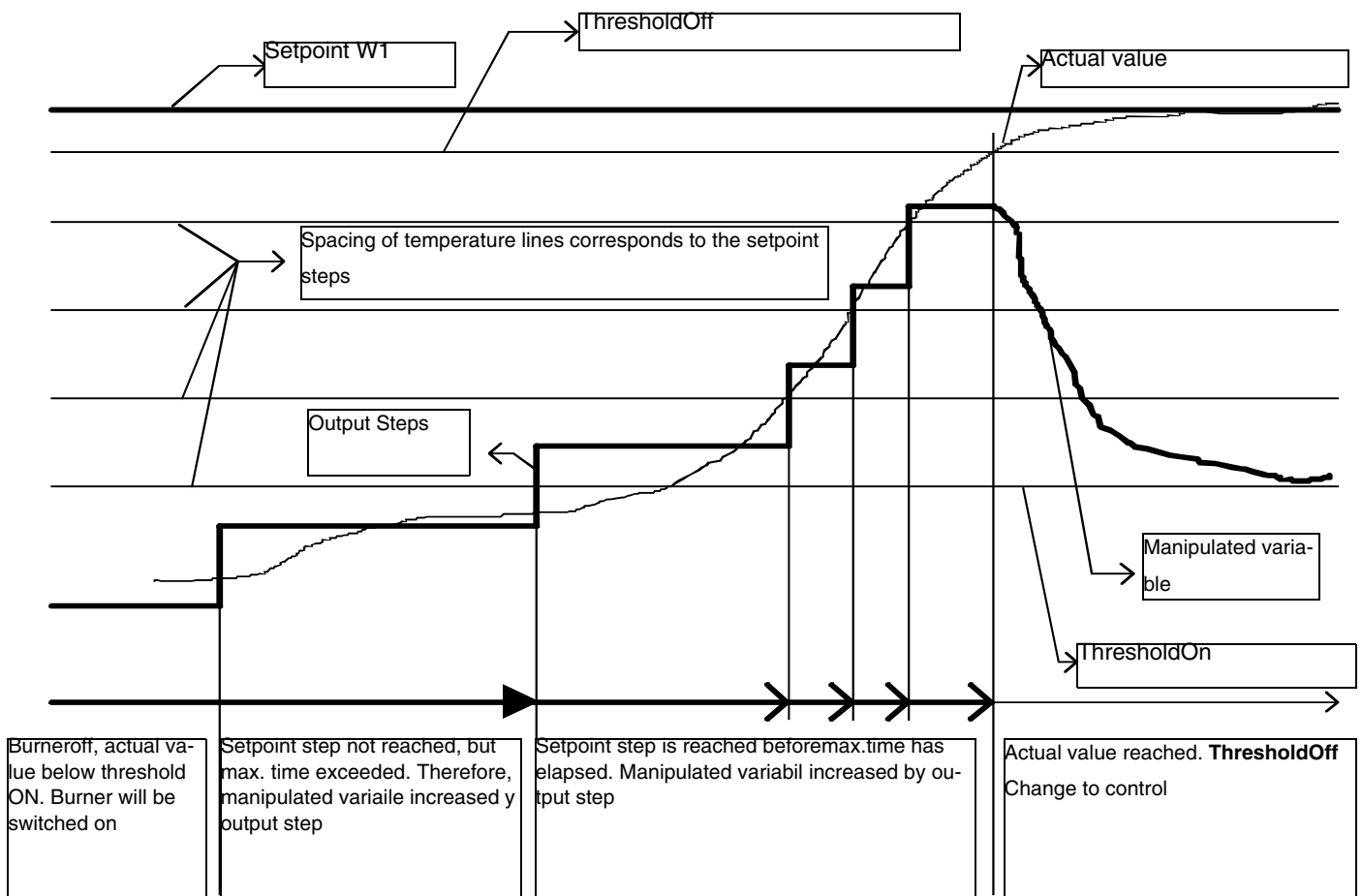

			MaxTme-Stage	1...63 min	Service	3 min	Cold start thermal shock protection, maximum time per step (multistage)
			ThresholdOff	1...100% Wcurrent	Service	80%	Cold start thermal shock protection deactivation level referred to the current setpoint (Wcurrent)
			Additional-Sens	deactivated	Service	deactivated Pt100 Pt1000 Ni1000	Select extra sensor for cold start thermal shock protection
			Temp Cold-Start	---	User	0...2000 °C	Display of temperature acquired by extra sensor for the cold start thermal shock protection function
			Setpoint Add-Sensor	60 °C	Service	0...450 °C	Setpoint for extra sensor for cold start thermal shock protection
			Release Stages	release	Service	no release/ release	Cold start thermal shock protection load step stage mode (multistage operation)



BURNER MANUAL OPERATION



The operator can decide if choosing burner manual operation at a settable fixed load or modulating operation through the automatic load controller, then can also set the burner shutdown by means of the "burner off" function.

Choose the type of operation (Au-tom / Manual / Off).

1st level	2nd level	3rd level	Password	Description
ManualOperation				Menu level for activating manual operation with the preselected load
	Au-tom/ Manual/Off			Selection of manual or automatic operation
		Automatic/ Burner on / Burner off	User	

Setting the load percentage for the manual operation

To set the load percentage at which the burner must operate in manual mode, proceed as described below.

1st level	2nd level	3rd level	Password	Description
ManualOperation				Menu level for activating manual operation with the preselected load
	SetLoad			Set target load
		0..100%	User	

ELECTRICAL CONNECTIONS AT 230 V

Terminal Blocks

LMV51.300B2 / LMV52.200B1 / LMV52.200B2 / LMV52.240B2

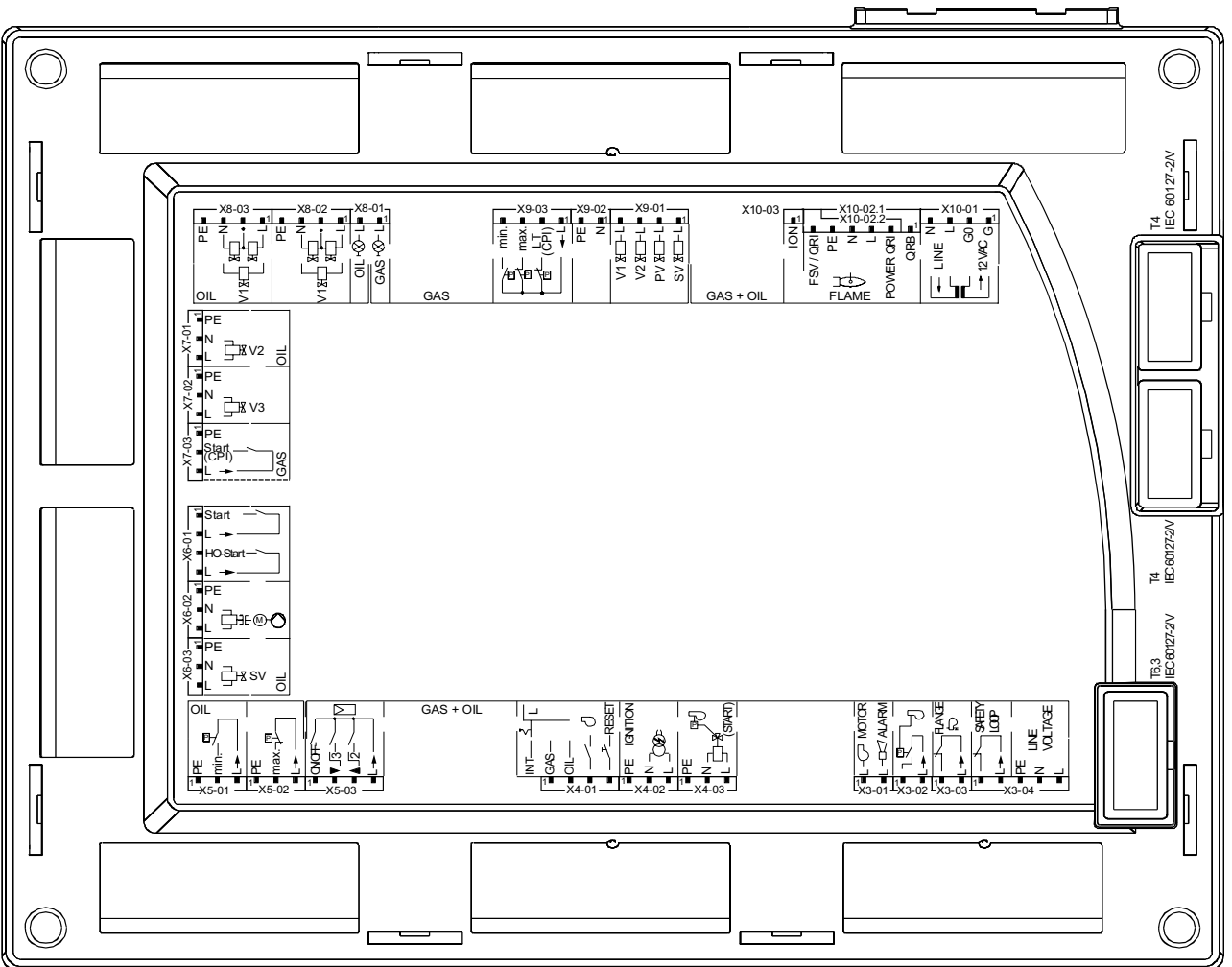
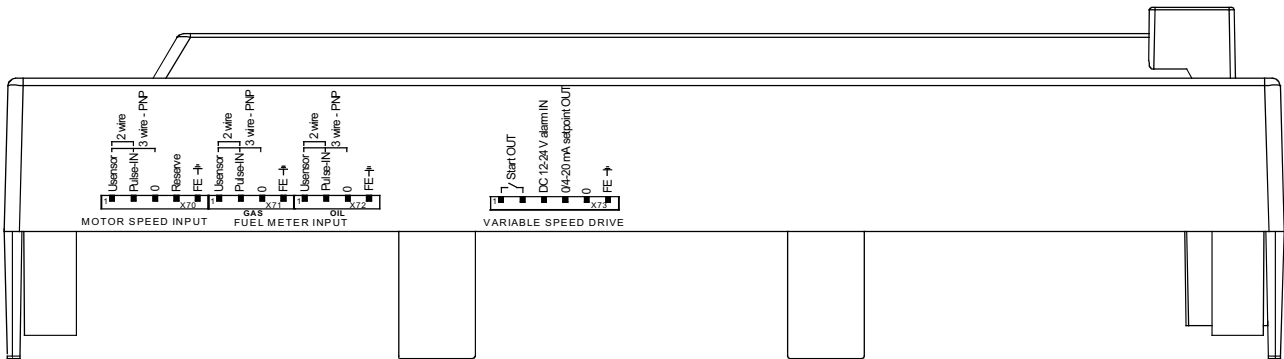

7550218/0404

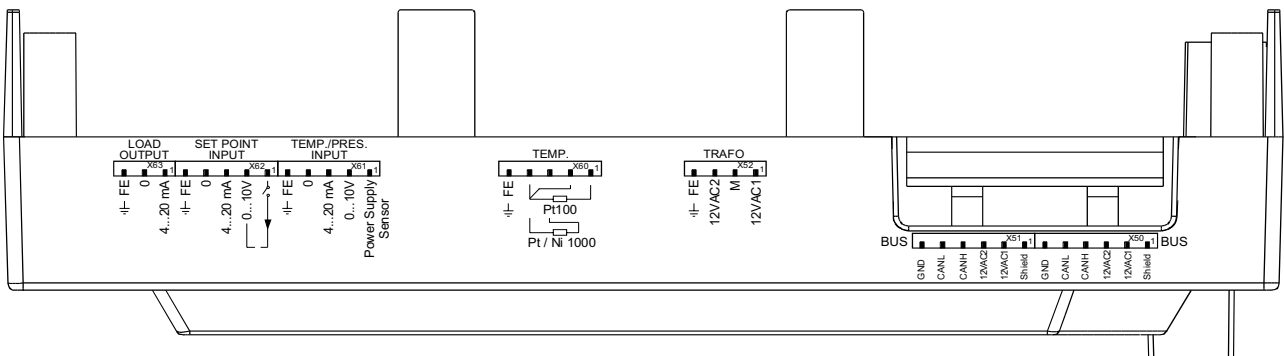

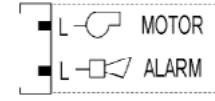
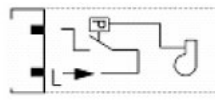
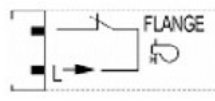
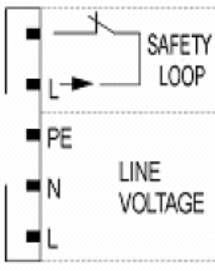
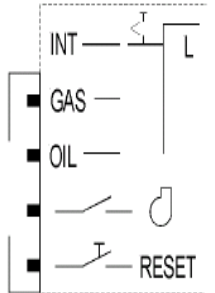
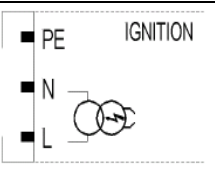
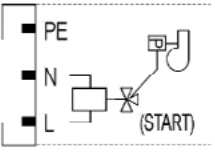
Terminal group	Connection symbol		Input	Output	Description of connection terminals	Electrical rating
X3-01	PIN1			x	Fan motor contactor	AC 230 V +10 % / -15 %, 50...60 Hz, 1 A, cos.0.4
	PIN2			x	Alarm	AC 230 V +10 % / -15 %, 50...60 Hz, 1 A, cos.0.4
X3-02	PIN1		x		Air pressure switch (LP)	AC 230 V +10 % / -15 %, 50...60 Hz, I _{max} 1.5 mA
	PIN2			x	Power signal for air pressure switch (LP)	AC 230 V +10 % / -15 %, 50...60 Hz, I _{max} 500 mA
X3-03	PIN1		x		End switch burner flange	AC 230 V +10 % / -15 %, 50...60 Hz, I _{max} 5 A
	PIN2			x	Power signal for end switch burner flange	AC 230 V +10 % / -15 %, 50...60 Hz, I _{max} 5 A
X3-04	PIN1		x		Safety loop	AC 230 V +10 % / -15 %, 50...60 Hz, I _{max} 5 A
	PIN2			x	Power signal for safety loop	AC 230 V +10 % / -15 %, 50...60 Hz, I _{max} 5 A
	PIN3			x	Protective earth (PE)	
	PIN4			x	Supply voltage neutral conductor (N)	
	PIN5			x	Supply voltage live conductor (L)	AC 230 V +10 % / -15 %, 50...60 Hz, fuse 6.3 AT (DIN EN 60 127 2 / 5)
X4-01					Fuel selection "internal" if pin 1-2 is not used	
	PIN1			x	Fuel selection gas	AC 230 V +10 % / -15 %, 50...60 Hz, I _{max} 1.5 mA
	PIN2			x	Fuel selection oil	AC 230 V +10 % / -15 %, 50...60 Hz, I _{max} 1.5 mA
	PIN3			x	Fan contactor contact (FCC) or flue gas recirculation pressure switch	AC 230 V +10 % / -15 %, 50...60 Hz, I _{max} 1.5 mA
	PIN4			x	Reset / manual lockout	AC 230 V +10 % / -15 %, 50...60 Hz, I _{max} 1.5 mA
X4-02	PIN1			x	Protective earth (PE)	
	PIN2			x	Neutral conductor (N)	
	PIN3			x	Ignition	AC 230 V +10 % / -15 %, 50...60 Hz, 2 A, cos.0.2
X4-03	PIN1			x	Protective earth (PE)	
	PIN2			x	Neutral conductor (N)	
	PIN3			x	Start signal or pressure switch relief (air pressure switch test valve)	AC 230 V +10 % / -15 %, 50...60 Hz, 0.5 A, cos.0.4

Terminal group	Connection symbol		Input	Output	Description of connection terminals	Electrical rating
X5-01	PIN1			x	Protective earth (PE)	
	PIN2		x		Pressure switch min-oil (DWmin-oil)	AC 230 V +10 % / -15 %, 50...60 Hz, I _{max} 1.5 mA
	PIN3			x	Power signal for pressure switch-min-oil (DWmin-oil)	AC 230 V +10 % / -15 %, 50...60 Hz, I _{max} 500 mA
X5-02	PIN1			x	Protective earth (PE)	
	PIN2		x		Pressure switch-max-oil (DWmax-oil)	AC 230 V +10 % / -15 %, 50...60 Hz, I _{max} 1.5 mA
	PIN3			x	Power signal for pressure switch-max-oil (DWmax-oil)	AC 230 V +10 % / -15 %, 50...60 Hz, I _{max} 500 mA
X5-03	PIN1		x		Controller (ON / OFF)	AC 230 V +10 % / -15 %, 50...60 Hz, I _{max} 1.5 mA
	PIN2		x		Controller closes / stage 3	AC 230 V +10 % / -15 %, 50...60 Hz, I _{max} 1.5 mA
	PIN3		x		Controller opens / stage 2	AC 230 V +10 % / -15 %, 50...60 Hz, I _{max} 1.5 mA
	PIN4			x	Power signal for control of controller	AC 230 V +10 % / -15 %, 50...60 Hz, I _{max} 500 mA
X6-01	PIN1		x		Start release oil	AC 230 V +10 % / -15 %, 50...60 Hz, I _{max} 1.5 mA
	PIN2			x	Power signal start release oil	AC 230 V +10 % / -15 %, 50...60 Hz, I _{max} 500 mA
	PIN3		x		Direct heavy oil start	AC 230 V +10 % / -15 %, 50...60 Hz, I _{max} 1.5 mA
	PIN4			x	Power signal direct heavy oil start	AC 230 V +10 % / -15 %, 50...60 Hz, I _{max} 500 mA
X6-02	PIN1			x	Protective earth (PE)	
	PIN2			x	Neutral conductor (N)	
	PIN3			x	Oil pump / magnetic coupling	AC 230 V +10 % / -15 %, 50...60 Hz, 2 A, cos.0.4
X6-03	PIN1			x	Protective earth (PE)	
	PIN2			x	Neutral conductor (N)	
	PIN3				Fuel valve (shutoff valve-oil)	AC 230 V +10 % / -15 %, 50...60 Hz, 1 A, cos.0.4

Terminal group	Connection symbol		Input	Output	Description of connection terminals	Electrical rating
X7-01	PIN1			x	Protective earth (PE)	
	PIN2			x	Neutral conductor (N)	
	PIN3				Fuel valve 2 (oil)	AC 230 V +10 % / -15 %, 50...60 Hz, 1 A, cos.0.4
X7-02	PIN1			x	Protective earth (PE)	
	PIN2			x	Neutral conductor (N)	
	PIN3				Fuel valve 3 (oil)	AC 230 V +10 % / -15 %, 50...60 Hz, 1 A, cos.0.4
X7-03	PIN1			x	Protective earth (PE)	
	PIN2		x		Start release gas CPL (LMV52...)	AC 230 V +10 % / -15 %, 50...60 Hz, I _{max} 1.5 mA
	PIN3			x	Power signal (reserve)	AC 230 V +10 % / -15 %, 50...60 Hz, I _{max} 500 mA

Terminal group	Connection symbol	Input	Output	Description of connection terminals	Electrical rating
X8-01		PIN2	x	Firing on oil	AC 230 V +10 % / -15 %, 50...60 Hz, 1 A, cos.0.4
		PIN1	x	Firing on gas	AC 230 V +10 % / -15 %, 50...60 Hz, 1 A, cos.0.4
X8-02		PIN4	x	Protective earth (PE)	
		PIN3	x	Neutral conductor (N)	
		PIN2	x	Wiring point for valves connected in series	
		PIN1	x	Fuel valve 1 (oil)	AC 230 V +10 % / -15 %, 50...60 Hz, 1 A, cos.0.4
X8-03		PIN4	x	Protective earth (PE)	
		PIN3	x	Neutral conductor (N)	
		PIN2	x	Wiring point for valves connected in series	
		PIN1	x	Fuel valve 1 (oil)	AC 230 V +10 % / -15 %, 50...60 Hz, 1 A, cos.0.4
X9-01		PIN4	x	Fuel valve 1 (gas)	AC 230 V +10 % / -15 %, 50...60 Hz, 2 A, cos.0.4
		PIN3	x	Fuel valve 2 (gas)	AC 230 V +10 % / -15 %, 50...60 Hz, 2 A, cos.0.4
		PIN2	x	Fuel valve (gas)	AC 230 V +10 % / -15 %, 50...60 Hz, 2 A, cos.0.4
		PIN1	x	Fuel valve (shutoff valve-(gas))	AC 230 V +10 % / -15 %, 50...60 Hz, 2 A, cos.0.4
X9-02		PIN2	x	Protective earth (PE)	
		PIN1	x	Neutral conductor (N)	
X9-03		PIN4	x	Pressure switch-min-gas, start release gas	AC 230 V +10 % / -15 %, 50...60 Hz, I _{max} 1.5 mA
		PIN3	x	Pressure switch-max-gas (DWmax-gas)	AC 230 V +10 % / -15 %, 50...60 Hz, I _{max} 1.5 mA
		PIN2	x	Pressure switch-valve proving-gas / leakage test or valve closing contact (CPI)	AC 230 V +10 % / -15 %, 50...60 Hz, I _{max} 1.5 mA
		PIN1	x	Power signal for pressure switch	AC 230 V +10 % / -15 %, 50...60 Hz, I _{max} 500 mA

Terminal group	Connection symbol	Input	Output	Description of connection terminals	Electrical rating	
X10-01		PIN4	x	Neutral conductor (N)	AC 230 V +10 % / -15 %, 50...60 Hz, max 1 mA	
		PIN3		x	Power signal transformer	
		PIN2	x		AC power signal GO	AC 12 V +10 % / -15 %, 50...60 Hz, max 1.2 mA
		PIN1	x		AC power signal fan motor (G)	
X10-02		PIN6	x	QRI... (IR detector) / QRA7... signal voltage	U _{max} DC 5 V	
		PIN5		x	Protective earth (PE)	
		PIN4		x	Neutral conductor (N)	
		PIN3		x	Power signal	AC 230 V +10 % / -15 %, 50...60 Hz, I _{max} 500 mA
		PIN2		x	QRI... (IR detector) / QRA7... power supply	DC 14 / 21 V C I _{max} 100 mA
		PIN1	x		QRB... signal voltage	Max. DC 8 V
X10-03		PIN1		x	Ionization probe (ION) (alternatively QRA2... / QRA4.U/QRA10..., refer to section <i>Description of inputs and out-puts</i>)	U _{max} (X3-04-PINS) I _{max} . 0.5 mA
X50		PIN6		x	Reference ground (PELV)	
		PIN5		x	Communication signal (CANL)	DC U <5 V, R _w = 120 Ω, level to ISO-DIS 11898
		PIN4		x	Communication signal (CANH)	
		PIN3		x	AC power supply for actuators / display and operating unit AZL5...	AC 12 V +10 % / -15 %, 50...60 Hz, Fuse max. 4 A
		PIN2		x	AC power supply for actuators / display and operating unit AZL5...	
		PIN1		x	Shield connection (functional earth)	
X51		PIN6		x	Reference ground (PELV)	
		PIN5		x	Communication signal (CANL)	DC U <5 V, R _w = 120 Ω, level to ISO-DIS 11898
		PIN4		x	Communication signal (CANH)	
		PIN3		x	AC power supply for actuators / display and operating unit AZL5...	AC 12 V +10 % / -15 %, 50...60 Hz, Fuse max. 4 A
		PIN2		x	AC power supply for actuators / display and operating unit AZL5...	
		PIN1		x	Shield connection (functional earth)	

X52		PIN4	x	(functional earth)	
		PIN3	x	AC power supply from transformer to LMV5... system	AC 12 V +10 % / -15 %, 50...60 Hz
		PIN2	x	Reference ground (PELV)	
		PIN1	x	AC power supply from transformer to LMV5... system	AC 12 V +10 % / -15 %, 50...60 Hz

Terminal group	Connection symbol	Input	Output	Description of connection terminals	Electrical rating	
Temperature / pressure controller						
X60		PIN5	x	Functional earth for shield connection		
		PIN4	x	Reference ground		
		PIN3	x	Temperature sensor input Pt / LG-Ni 1000		
		PIN2	x	Line compensation temperature sensor PT100		
		PIN1	x	Temperature sensor input PT100		
X61		PIN5	x	Functional earth for shield connection		
		PIN4	x	Reference ground		
		PIN3	x	Current input for temperature / pressure signal 0/4...20 mA	DC 0/4...20 mA	
		PIN2	x	Voltage input for temperature / pressure signal DC 0...10 V	DC 0...10 V	
		PIN1		x	Power supply for temperature / pressure transmitter	approx. DC 20 V Max. 25 mA
X62		PIN5	x	Functional earth for shield connection		
		PIN4	x	Reference ground		
		PIN3	x	Current input for setpoint or load	DC 0...20 mA	
		PIN2	x	Voltage input for setpoint or load	DC 0...10 V	
		PIN1		x	Power supply for setpoint changeover	approx. DC 24 V Max. 2 mA
X63		PIN3	x	Functional earth for shield connection		
		PIN2		x	Reference ground	
		PIN1		x	Current output for burner (LOAD OUTPUT)	DC 4...20 mA, R _{Lmax} = 500 Ω

PROGRAMMING THE VSD

To program the VSD, use the BOP interface panel.



BOP - SED2









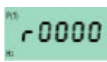

The BOP allows setting the parameters in order to set the VSD specifically for the motor used. It has keys and a 5 position LCD: it shows the parameter numbers rxxxx or Pxxxx, the parametric values, the parameter unit (i.e. [A], [V], [HZ], [s]), alarms Axxxx or fault signalling Fxxxx and the reference and actual values.

ATTENTION! the VSD is factory set for the burner fan motor, then it is not necessary to program it.

The following procedure can be used only if the VSD is to be replaced with a new not parametrized VSD, or if the VSD must be set to use it coupled to another motor (in this case check if the VSD maximum output matches the power requested by the motor).



The following procedure resets the parameters on default value set by Siemens and it allows setting only the parameters necessary for the burner operation. By means of this procedure, parameters accidentally set can be cancelled.

Description of the SED2 VSD key functions

Display/keys	Functions	Descriptions
	Status display	The LCD (5-digit display for BOP, multiline clear text display for AOP) shows the settings presently used by the VSD or used to parameterize the VSD).
	Start motor	Pressing this button starts the VSD. This button is enabled for manual mode as part of the factory setting.
	Stop motor	OFF1 Pressing this button stops the VSD within the selected ramp-down time. This button is enabled for manual mode as part of the factory setting. OFF2 Pressing this button twice (or once with sustained pressure) causes the motor to coast freely to a standstill. This function is enabled in the manual and automatic operating modes.
	Changeover to manual control	Pressing this button while the VSD is running sets the input logic so that the operator controls the SED2. In this mode, none of the controlled variables have any influence on the control of the VSD.
	Changeover to automatic control	In automatic mode, all I/Os are set to represent the system-dependent variables. No manual inputs are accepted. The controller responds to changes depending on its parameter setting. However, it is possible to change system parameters in automatic mode.
	Functions	This button allows for displaying additional information. Also refer to the section <i>Buttons with special functions</i> in the AOP Operating Instructions. Multiple display mode: when you press this button for 2 seconds during operation, the following information is displayed regardless of the parameter: 1. DC link voltage (indicated by d – units V). 2. Output current (A). 3. Output frequency (Hz). 4. Output voltage (indicated by o – units V). 5. The value selected in P0005 (if P0005 is configured to display any of the above (1 to 4), the value is not redisplayed). Briefly press the button repeatedly to cycle through the above displays. Pressing again this button for a sustained time exits the multiple display mode. Error acknowledgement: when a fault occurs and the SED2 trips, use this button to acknowledge the error. Jump function: you can jump from any parameter (rXXXX or PXXXX) directly to r0000 by pressing the Fn button briefly. This allows you to modify another parameter if required. After jumping to r0000, press the Fn button again to return to the starting point.
	AOP only	Pressing buttons Fn and P simultaneously opens the main menu.
	Access to parameters	Pressing this button allows you to: 1. Access the parameters 2.: Exit the parameter by accepting its value.
	Increase value	Press this button to increase the value displayed. This button helps increase the current value during parameterization. In manual mode, this button allows for increasing the speed (internal motor potentiometer).
	Decrease value	Press this button to decrease the value displayed. This button helps decrease the current value during parameterization. In manual mode, this button allows for decreasing the speed (internal motor potentiometer).



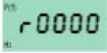

Programming

To enter the programming mode, proceed as follows:



- 1 press key "P" 
- 2 message $\Gamma 000$  will be displayed;
- 3 press  until, parameter "P0010" is displayed;
- 4 press "P" to enter the page then by pressing  change **function from 0 to 1** to program the quick pages;
- 5 press "P" again to confirm and exit.

Successively, by pressing  go to next pages, and with the same procedure set next data:

Page	Description	Value to be set
P0304	Rated motor voltage	usually 400V
P0305	Rated motor current	
P0307	Rated motor power	
P0310	Rated motor frequency	usually 50Hz
P0311	Rated motor speed	M-1
P1080	Min. motor frequency	usually 0Hz
P1082	Max. motor frequency	usually 50Hz
P1120	Ramp-up time	usually 20 sec.
P1121	Ramp-down time	usually 20 sec.

- 6 now, to automatically execute the calculating procedure of the parameters,
- 7 choose page **P3900**
- 8  press  to pass from 0 to 1;
- 9  press  to confirm: the calculating procedure of the parameters will be executed.
- 10 Once the above pages are set, press "P" to exit the programming mode.







Attention, once the parameters calculation is executed through function "P3900", the function "P0010", that was previously set **from 0 to 1**, is automatically reset to **0**. Infacts, if function "P0010", will remain on **1**, VSD would stay on programming mode and could not work.



Note: to exit manually from the programming mode, go back to page "P010", press  and , change **from 1 to 0** to end the programming function.

Attention: any manual exit without parameter calculation in "P3900", does not allow correct VSD parameter setting.

Attention: once the calculation in "P3900" is performed, the VSD reset some paramters on default setting, as for example the maximum frequency on "P2000", then it will be necessary to change again some settings

Proceed as follows:

- 11 press 
- 12 press  until "P0003" () is shown;
- 13 press "P" to enter: change function from **1 to function 3** (that allows showing all the pages); then press "P" to confirm and exit.
- 14 press  until "P0006" is shown (**Visualisation of the output frequency**): press  function from **2 to function 4** then press .
- 15 Choose page "P0700" (**Selection of command source**): to select the command source press  to enter the relevant page and see "IN000" (Automatic mode supply): then, **choose 2** (in order that the input signal comes from terminals, in automatic mode);
- 16 press  to enter again into "P0700";

-
- 17 press  to choose “IN001” (Manual mode supply),
 - 18 **choose 1** (input signal from BOP for manual mode operation);
 - 19 the choose page “P0756” (**Type of input signals**)
 - 20 press  to enter “IN000”
 - 21 **set 2** (to select the 0÷20 mA input signal)
 - 22 then press P and  again.

Only for MM440 VSD

- 23 Choose page “P1237” (**Enablign breaking resistors**): set **1**, or choose values on the following table:

0 – not enabled

1 – 5% duty cycle

2 – 10% duty cycle

3 – 20% duty cycleo

4 – 50% duty cycleo

5– 100% duty cycle

- 24 Then select “P1820” (**motor direction of rotation**) and set the required direction

- 25 by means of  choose “P2000” (**Max. Frequency**): press  to enter the page and press  to set frequency at **52,60 Hz**;

- 26 press  again to confirm and exit.

- 27 Go back to “P0003” then from **3 to 1**.

- 28 Go back to page **Γ000**

- 29 Exit by pressing 

Attention: remember to select also the two micro-DIP-Switches to “On” postion

Note: the device automatically go back to main visualisation if no key is pressed within some seconds.

Attention: parameter **P0640** represents factor “% motor overload” (ampere) while paramter **P0305** represents the rated current.

Once switched off, wait for at least 5 minutes, before opening the device. The line capacitors are at a dangerous voltage also after switching off. Terminals L1, L2, L3, U, V, W can be at dangerous voltage even if the VSD is not working.









C.I.B. UNIGAS S.p.A.
Via L.Galvani, 9 - 35011 Campodarsego (PD) - ITALY
Tel. +39 049 9200944 - Fax +39 049 9200945/9201269
web site: www.cibunigas.it - e-mail: cibunigas@cibunigas.it

Note: Specifications and and data subject to change. Errors and omissions excepted.

Siemens LMV 5x



User manual



SIEMENS LMV CONTROLLED BURNERS

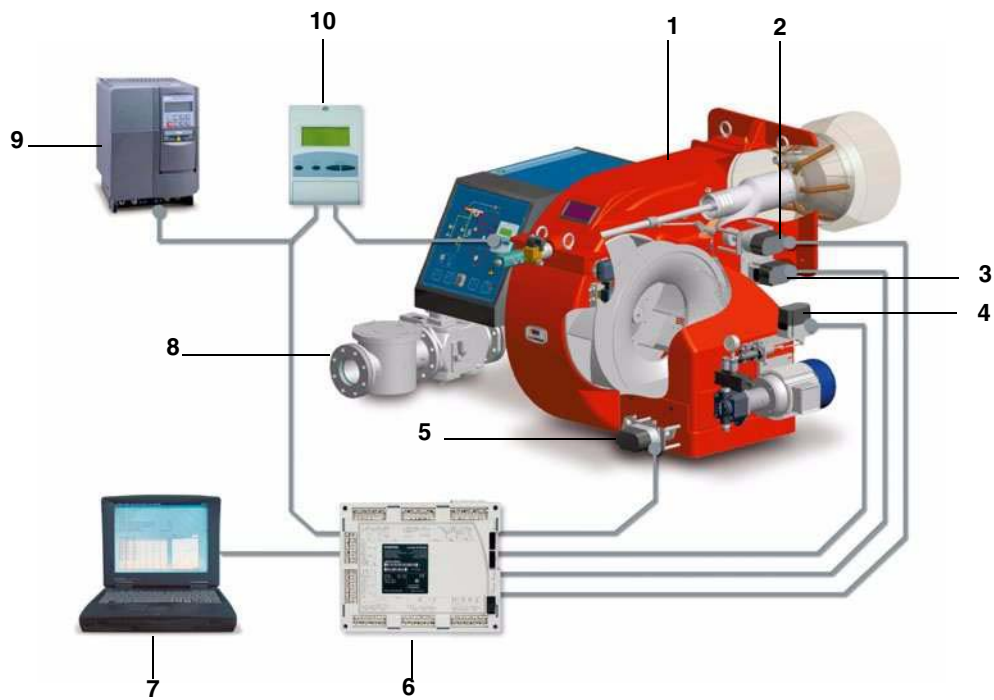

Keys

- 1 Burner
- 2 Combustion head actuator
- 3 Gas butterfly valve actuator
- 4 Oil pressure governor actuator
- 5 Air damper actuator
- 6 Siemens LMV burner control
- 7 Personal Computer
- 8 Gas train
- 9 Inverter
- 10 Siemens AZL User interface

The control system is made of the Siemens LMV central unit (6) that performs all the burner control functions and of the Siemens AZL local programming unit (10) that interfaces the system with the user.

Main features:

- no mechanical linkages
- built-in burner control box
- built-in gas proving system
- more flame checking devices available for several applications
- PID load controller
- up to six actuators can be controlled. Each of them is independent for the best burner setup
- best air/fuel ratio. Repeatability and precision of set adjustments
- Modbus communication
- multilevel password
- settings via PC
- adjustable prepurging time (according to the relevant Standards)
- continuous ventilation
- post purging (adjustable time)
- proving system settable to on and off
- adjustable proving system time for all the valve volumes
- load controller settable to on and off
- thermal shock protection function settable to on and off (for cold starts)
- continuous operation and flame detection probe

Note: the picture above shows a complete control system.

USER SETTINGS

Go on adjusting the burner.

Users can set only the LMV parameters that can be accessed without password: (see “Adjusting the temperature set-point”). The Siemens AZL User Interface allows programming the Siemens LMV control box and monitoring the system data.

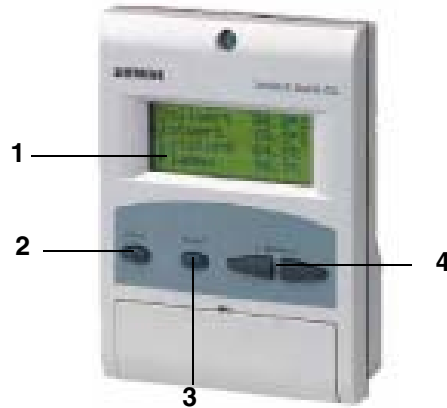

The user interface is made of:

1. display: it shows menus and parameters
2. ESC key (previous level): it goes back to the previous level menu or exits the programming mode without changing data.
3. ENTER key (next level): it confirms the data changing and jumps to the next menu/parameter.
4. SELECT keys: they select a menu item and change the parameter values.

To know the actuator functions, proceed as follows:

- 1 remove the actuator covers

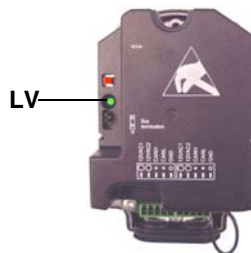

- 2 check the number of the LV green LED blinks for each actuator:

Blinks	Actuator function
1 blink	air damper actuator
2 blinks	gas butterfly valve actuator
3 blinks	oil pressure governor actuator
4 blinks	auxiliary actuator
5 blinks	auxiliary actuator
6 blinks	auxiliary actuator



CAUTION: it is recommended not to adjust the actuators. Anyway, never press the actuator red button, otherwise the fundamental parameters, necessary for the burner operation, will be cancelled. The burner will therefore continuously lock out.

Start-up procedure

- 1 Turn the burner on according to the following:
 - ual fuel burners: choose the requested fuel by means of the related control panel switch
 - one fuel burners: turn the burner on by means of the burner main switch (placed on the burner control panel)
- 2 the LMV controller starts the system test cycle: the AZL display shows the **System Test** message; at the end of the test, it shows the main page and the system stops (the safety chain is open) waiting for the startup enabling signal (standby - Program phase no. 12)

Setpoint	80°C
Act	value
78°C	
Fuel	GAS

Main page

- 3 check the fan motor rotation;
- 4 (light/heavy oil burners) with the electrical panel open, prime the oil pump acting directly on the related **CP** contactor (see next picture): check the pump motor rotation and keep pressing for some seconds until the oil circuit is charged;

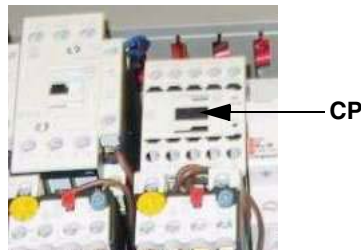

- 5 bleed the air from the **M** pressure gauge port (see next picture) by loosening the cap without removing it, then release the contactor.

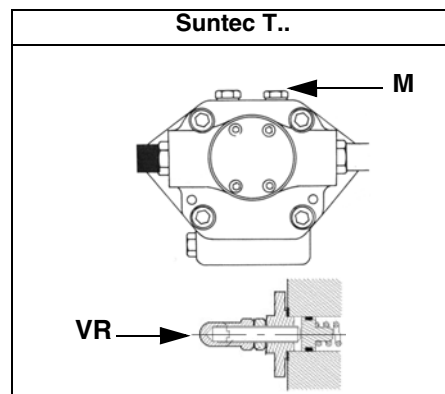

- 6 make the safety chain enabling the system to start up
 - 7 the combustion cycle starts:
 - **Prepurging** (program phase no.30)
 - **Driving to ignition position** (program phase no.36)
 - **Ignition position** (program phase no.38)
 - **Fuel** (the fuel solenoid valves open)
 - **Flame** (the flame lights up)
 - **Driving to low flame** (the actuator drives to low flame).
- NOTE:** the **C** and **A**, on the .

Once the ignition cycle ends, the main page is shown:

Setpoint	80°C
Act	value
78°C	
Load	24%

Main page

Set point: temperature set-point

Act value: actual temperature value

Load: load percentage (burner output)

Flame: percentage of flame detection current.

By pressing the ENTER key the display shows the second page:

Fuel	0.0	Air	1.8
Ax1		VSD	0.0
Ax2		O2	
Ax3		Ld	0.0

Second page

Fuel: it shows (in degrees) the fuel actuator position.

Air: it shows (in degrees) the air actuator position.

Ax1..3: auxiliaries.

VSD: % value on the inverter maximum frequency

O2: oxygen percentage

Ld: load percentage (burner output).

Press the ENTER key to go back to the main page.

To access the **main menu**, from the main page, press the ESC key twice:

Operational status
Operation
Manual Operation
Params& Display

Main menu

By pressing the ESC key once, the **Operational Status** (first item in the main menu) menu is directly shown:

Normal operation
Status/Reset
Fault History
Lockout History

the **Operational Status** menu provides the following items:

Normal operation: by selecting this item and pressing the ENTER key, the main page is shown; press ESC to go back to the main menu.

Status/Reset: it shows system errors or faults occurring / it represents the lockout reset function.

Fault History: by selecting this item and pressing the ENTER key, the Lockout History will be shown about the last 21 faults occurred.

Lockout History: by selecting this item and pressing the ENTER key, the Lockout History will be shown about the last 9 lockouts occurred, and the related date and hour.

Alarm act/deact: enable/disable the horn in case of alarm.

Fault History

To visualise the **Fault History**, select it and press the ENTER key. The message will be as:

1 Class:	05Gas
Code BF	Phase: 10
Diag.: 00	Lod: 0.0
Start No.	88

alternating by an error message as:

O2 control and limiter automat deactivated
--

To see the other Fault History pages, press the arrow keys.

To exit the Fault History pages, press ESC.

Lockout History

To visualise the **Lockout History**, choose the related item and press ENTER. The message will be:

1	10.08.07	13.47
C:71	D:00	F: 12
Start No:	88	
Load	0.0	Gas

alternating by an error message as:

No flame at end of safety time

To see the other Lockout History pages, press the arrow keys.

To exit the Lockout History pages, press ESC.

Setting the temperature set-point value

To set the temperature set-point value, that is the generator operating temperature; proceed as follows.

From the main page, enter the main menu by pressing the ESC key twice:

Operational Status
Operation
Manual Operation
Params& Display

by means of the arrow keys, select "Params&Display", press ENTER: the system will ask you to enter the proper password

```

Access w-out PW
Access Serv
Access OEM
Access LS

```

by means of the arrow keys, select “Access w-out pass” (access without password - user level), confirm by pressing ENTER. The other levels require password reserved to the Technical Service, to the Manufacturer, etc. The menu accessed without password is the following:

```

BurnerControl
RatioControl
O2Contr./Guard.
LoadController

```

Choose “LoadController” and press ENTER: the following menu is shown:

```

ControllerParam
Configuration
Adaption
SW Version

```

Choose “ControllerParam” and press ENTER: the following menu is displayed:

```

ContrlParamList
MinActuatorStep
SW_FilterTmeCon
SetPointW1

```

Choose “SetPointW1” and press ENTER:

```

SetpointW1
Curr: 90°
New: 90°

```

Curr: it shows the current set-point; use the arrows keys to change it.

NOTE: the available range depends on the probe used; the measure unit of the detected data and its relevant limits are set by “Service” level parameters.

Once the new set-point is set, confirm by pressing ENTER, otherwise exit without changings by pressing ESC.

Press ESC to exit the set-point programming mode.

Once the temperature set-point W1 is imposed, set the Switch-on (SDon) and the Switch-off (SDoff) point of the 2-position controller:

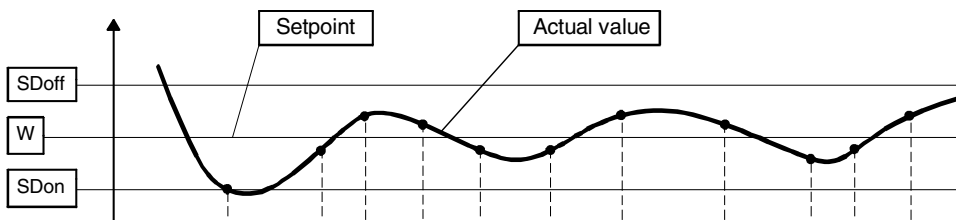

To set these values, select the item SD_ModOn (SDOn), by scrolling down the “Load controller” menu with the arrow keys and press ENTER:

```
SetPointW1
SetPointW2
SD_ModOn
SD_ModOff
```

the display will show:

```
SD_ModOn
Curr: 1.0%
New: 1.0%
```

The default value for this parameter is 1% that is, the burner will light again at a temperature 1% lower than the set-point. Change value, if needed, by means of the arrow keys; press ENTER to confirm and the press ESC to exit. Press only ESC to exit without changing.

Now choose SD_ModOff always scrolling down the Load Controller menu, by means of the arrow keys, and press ENTER.

```
SetPointW1
SetPointW2
SD_ModOn
SD_ModOff
```

the display will show:

```
SD_ModOff
Curr: 10.0%
New: 10.0%
```

The default value for this parameter is 10% that is, the burner will turn off at a temperature 1% higher than the set-point. Change value, if needed, by means of the arrow keys; press ENTER to confirm and the press ESC to exit. Press only ESC to exit without changing.

Press the ESC key until the following menu is shown:

```
BurnerControl
RatioControl
O2Contr./Guard.
LoadController
```

scroll this menu down until the item "AZL" is reached

```
LoadController
AZL
Actuators
VSD Module
```

confirm by pressing ENTER:

```
Times
Languages
DateFormat
PhysicalUnits
```

Times: it sets the "Summer (SUM) Time / Winter (WIN) Time" operation and the continent (EU - Europe; US - United States)

```
Sum/Winter Time
Time EU/US
```

choose the Summertime/Wintertime mode desired and confirm by pressing ENTER; press ESC to exit.
Set the time zone (Time EU/US) in the same way.

Languages: it allows setting the current language

```
Languages
Curr: Italiano
New: English
```

choose the desired language and confirm by pressing ENTER; press ESC to exit.

DateFormat: it allows setting the date format as DD-MM-YY (day-month-year) or MM-DD-YY (month-day-year)

```
DateFormat
Curr: DD-MM-YY
New: MM-DD-YY
```

choose the desired format and confirm by pressing ENTER; press ESC to exit.

PhysicalUnits: it allows setting the measuring units for temperature and pressure

```
UnitTemperature
UnitPressure
```

Temperature units: °C or °F

Pressure units: bar or psi.

choose the desired unit and confirm by pressing ENTER; press ESC to exit.

System lockout

If the system locks out, the following message will appear:

```
1 Class:          05Gas
Code BF          Phase: 10
Diag.: 00        Lod:  0.0
Start No.        88
```

call the Technical Service and tell the message data.

Cold start thermal shock (CSTP)

If there is a steam boiler that must start up cold in the plant, the fireman will heat the boiler keeping the burner at the lowest output to prevent thermal shocks.

The LMV control box provides the CSTP (Cold Start Thermal Schock) function that is already set by the Technical service (access by reserved password).

if this function is enabled, when the burner starts up the "Thermal shock protection activated" message will be shown.

If this function is not enabled, after startup, the burner will rapidly increase the load according to the requested value and, if necessary, to the maximum output.

Manual mode

To by-pass the thermal protection or not to let the burner operate in high flame stage after ignition, the manuale mode is provided.

To choose the manual mode (Manual Operation), use the SELECT arrow keys

```
Operational Status
Operation
Manual Operation
Params& Display
```

Items to be set are the following:

```
SetLoad
Autom/Manual/Off
```

SetLoad: to set the required load percentage

```
SetLoad
Curr: 0.0%
New: 20.0%
```

set the required percentage and confirm by pressing ENTER; press ESC to exit.

```
SetLoad
Autom/Manual/Off
```

choose "Autom/Manual/Off

```
Autom/Manual/Off
Att: Automatic
Nuov: Burner On
```

three modes are provided:

Automatic: automatic operation

Burner on: manual operation

Burner off: burner in stand-by

If the BurnerOn mode is chosen, the burner does not follow the modulator and probe settings, but operates at the set load.

	Caution: if BurnerOff mode is selected, the burner stays in stand-by
	Caution: in the BurnerOn mode, the safety thresholds are set by the Technical Service.

SPARE PARTS

Description	Code
SIEMENS LMV51.100 - 110V BURNER CONTROL	2020460
SIEMENS LMV51.100 - 230V BURNER CONTROL	2020456
SIEMENS LMV51.200 - 110V BURNER CONTROL	2020463
SIEMENS LMV51.200 - 230V BURNER CONTROL	2020457
SIEMENS LMV52.200 - 110V BURNER CONTROL	2020461
SIEMENS LMV52.200 - 230V BURNER CONTROL	2020459
SIEMENS PLL52.110 O2 PCB FOR LMV52	2022111
AZL52.00 USER INTERFACE	2022112
AZL52.09 USER INTERFACE	2022121
AGG5.220 - 220V POWER SUPPLY	2022103
AGG5.210 - 110V POWER SUPPLY	2022113
SIEMENS SQM45 ACTUATOR	2480070
SIEMENS SQM48 ACTUATOR	2480071
SIEMENS QRI2A2 IR PROBE (FRONTAL ILLUMINATION)	2510028
SIEMENS QRI2B2 IR PROBE (LATERAL ILLUMINATION)	2510027
SIEMENS AGG5.310 SPEED SENSOR	2512108
SIEMENS QGO OXYGEN PROBE	2570304









C.I.B. UNIGAS S.p.A.
Via L.Galvani, 9 - 35011 Campodarsego (PD) - ITALY
Tel. +39 049 9200944 - Fax +39 049 9200945/9201269
web site: www.cibunigas.it - e-mail: cibunigas@cibunigas.it

RECOMMENDATIONS FOR LMV5x CONNECTIONS

Connections affected by EMC noises are related to the bus cable (actuator line cable, PLL52), detection probe cable, speed sensor cable, 4-20mA signal cable that controls the VSD.

Input and power cables (400V e 230V) must be laid separately from the signal cables.

The bus cable between control panel and burner and between burner and PLL52 board (used when O2 trim control must be performed) must be laid separately and far from power cables.

When long cables must be provided, it is recommended to put the bus cable into a pipe or a metallic sheath: the sheath ends must be grounded with suitable rings.

Provide a shielded three-pole cable type FG7OH2R+T (see Annex 1), between VSD and motor; earth must be outside the shielding.

Shielding must get to the lower part of the VSD and get to the motor junction box. Shielding must be connected to the equipotential ground on both ends, better with suitable rings.

Otherwise, a standard cable can be used also but put inside a pipe or metallic sheath (the sheath ends must be grounded with suitable rings) and an earth external wire for the motor ground.

The cable for the 4÷20mA signal that controls the VSD, must be shielded, only LMV5x side ends connected to the equipotential terminal. If the VSD is not inside the control panel, the cable must be laid separately inside a metallic sheath earthed by means of rings.

As for the speed sensor cable and QRI detection probe cable, provide a "Ethernet " cat.5 or 6 cable, inside a metallic sheath (with ends earthed by means of rings) and laid separately from the motor cable.

As the sensor uses three wires, divide and twist the pairs to avoid noises. Alternatively, provide a 3x2x0,50 twisted cable Liycy type (see Annex 2).

In case of O2 trim control version, O2 probe and PLL52 board must be connected by means of a 3x2x0,50 twisted cable Liycy type (see Annex 2).

NB: when a shielding has both ends wired to Earth, be sure they are at the same potential. If there is any Voltage difference, ground just one of the two ones, generally the one closest to the weakest, respect to EMC, component. Anyway give way to the burner control, that is wire to ground the end of the shielding closest to the LMV. For instance, the cable between LMV and VSD, if the shielding has only one end wired to Earth, this one has to be the one LMV side.

Annex1 – Example for motor cable



FG70H2R+T 0,6/1 kV
A RIDOTTA EMISSIONE
DI ALOGENI

FG70H2R+T 0,6/1 kV
WITH REDUCED
HALOGEN EMISSION

INDUSTRIA E AUTOMAZIONE



CARATTERISTICHE TECNICHE

Colore delle anime:		UNEL 00722 / VDE 0293 (Tab. 8)
Conduttori:	rame rosso elettrolitico	normativa CEI EN 60228 Cl.5 (Tabella 9)
Isolante:	elastomero silanico di qualità G7	normativa CEI 20-11 - CEI EN 50363
Separatore:	nastro poliestere-mylar	
Schermatura:	a treccia capillari di rame rosso elettrolitico cop. > 80 %	
Guaina esterna:	PVC di qualità TM2	normativa CEI 20-11 - CEI EN 50363
Colore della guaina:	Grigio RAL 7035	
Prova N.P. verticale:	su singolo conduttore o cavo isolato	normativa CEI EN 60332-1-2
Prova GAS emessi:	durante la combustione	normativa CEI EN 50267-2-1
Resistenza agli olii:		normativa CEI 20-34/0-1
Prova N.P.I.:		normativa CEI 20-22/2
Resistenza elettrica:	relativamente alla sezione	normativa CEI EN 60228 (Tabella 9)
Tens. nominale Uo/U:	0,6/1 kV	
Tensione di prova:	4000 V	
Temperatura d'esercizio:	(- 25 °C ÷ + 90 °C)	
Temperatura di corto circuito:	250 °C	
Marcatura:	BERICA CAVI S.P.A. (VI) FG70H2R + T 0,6/1 kV O.R. CEI 20-22 II CE Anno/Lotto - N° Anime x Sezione + T	
Raggio di curvatura:	minimo 15 volte diametro esterno	

TECHNICAL FEATURES

<i>Cores colour code:</i>		UNEL 00722 / VDE 0293 (Tab. 8)
<i>Conductors :</i>	<i>fine wires stranded of bare copper</i>	CEI EN 60228 Cl.5 (Tab.9) rule
<i>Insulation:</i>	<i>G7 quality rubber</i>	CEI 20-11 - CEI EN 50363 rules
<i>Assembling:</i>	<i>polyester-mylar tape</i>	
<i>Shield:</i>	<i>bare copper braid 80% covering</i>	
<i>Outer sheath:</i>	<i>TM2 quality PVC</i>	CEI 20-11 - CEI EN 50363 rules
<i>Sheath colour code:</i>	<i>Grey RAL 7035</i>	
<i>Vertical fire retardant test:</i>	<i>on single conductor or insulated cable</i>	CEI EN 60332-1-2 rule
<i>Emission GAS test:</i>	<i>during the combustion</i>	CEI EN 50267-2-1 rule
<i>Oil resistant test:</i>		CEI 20-34/0-1 rule
<i>Flame retardant test:</i>		CEI 20-22/2 rule
<i>Electric resistance:</i>	<i>according to</i>	CEI EN 60228 (Tab. 9)
<i>Working voltage:</i>	<i>0,6/1 kV</i>	
<i>Testing voltage:</i>	<i>4000 V</i>	
<i>Working temperature:</i>	<i>(-25 °C ÷ +90 °C)</i>	
<i>Short circuit temperature:</i>	<i>250 °C</i>	
<i>Outer printing:</i>	<i>BERICA CAVI S.P.A. (VI) FG70H2R + T 0,6/1 kV O.R. CEI 20-22 II CE - Year/Lot - Nr. of cond. by cross sect. + T.</i>	
<i>Bending radius:</i>	<i>cable outer diameter x 15</i>	

Annex 2 – Example for sensor cable

CAVI TIPO "Li-YCY-P" A COPPIE SCHERMATI A TRECCIA

IMPIEGO: Cavi schermati per segnali e trasmissione dati per applicazioni in elettronica ed informatica, efficaci contro le interferenze elettromagnetiche ed atti ad offrire una protezione contro influenze capacitive dovute a campi elettrici.

CABLES TYPE "Li-YCY-P" TWISTED PAIRS, TINNED COPPER BRAID SHIELD

STANDARD USE: Signal and data transmission shielded cables for electronics and information technology applications, effective against electromagnetic interferences and suited to offer protection against capacitive influences due to electric fields.

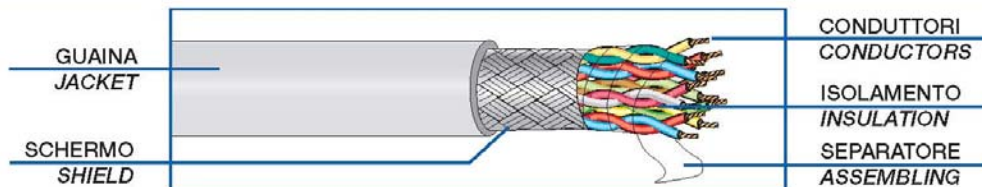

CARATTERISTICHE TECNICHE		TECHNICAL FEATURES
CONDUTTORI: Flessibili in rame rosso sec. CEI 20-29 (IEC 228) Cl. 5, VDE 0295 Cl. 5, NF C32-013 (0,34 mm ² : VDE 0295 Cl.2)		CONDUCTORS: Flexible bare copper conductors CEI 20-29 (IEC 228) Cl. 5, VDE 0295 Cl. 5, NF C32-013 Ref. (0,34 mm ² : VDE 0295 Cl.2)
ISOLANTE: Polivinilcloruro (PVC) Sec. CEI 20-11 Cl. R2, VDE 0207 Cl. Y12 Codici colori: a norma DIN 47100		INSULATION: Polyvinylchloride (PVC) CEI 20-11 Cl. R2, VDE 0207 Cl. Y12 Ref. Colour code according to DIN 47100
SEPARATORE: Nastro di poliestere		ASSEMBLING: Polyester tape helically wound
SCHERMATURA: A treccia di rame stagnato Cordina di continuità a richiesta		SHIELD: Tinned copper braid On request with drain wire
GUAINA ESTERNA: Polivinilcloruro (PVC) Sec. CEI 20-20 Cl. TM2, VDE 0207 Cl. YM2 colore: grigio (diverso a richiesta)		JACKET: Polyvinylchloride (PVC) CEI 20-20 Cl. TM2, VDE 0207 Cl. YM2 Ref. colour: grey or on request
RESISTENZA ELETTRICA DEI CONDUTTORI: 0,14 mm ² : <148 Ohm/Km 0,25 mm ² : <79 Ohm/Km 0,34 mm ² : <55 Ohm/Km 0,50 mm ² : <39 Ohm/Km 0,75 mm ² : <26 Ohm/Km 1mm ² : <19,5 Ohm/Km		ELECTRICAL CONDUCTOR RESISTANCE: 0,14 mm ² : <148 Ohm/Km 0,25 mm ² : <79 Ohm/Km 0,34 mm ² : <55 Ohm/Km 0,50 mm ² : <39 Ohm/Km 0,75 mm ² : <26 Ohm/Km 1 mm ² : <19,5 Ohm/Km
TEMPERATURA DI ESERCIZIO: posa fissa: -25°C + 70°C posa mobile: -15°C + 70°C		WORKING TEMPERATURE: fixed installation: -25°C + 70°C flexing: -15°C + 70°C
RAGGIO DI CURVATURA: 15 volte il diametro del cavo		BENDING RADIUS: 15 times overall diameter of cable
TENSIONE DI ESERCIZIO: 250 V		WORKING VOLTAGE: 250 V
TENSIONE DI PROVA: 1500 V		TEST VOLTAGE: 1500 V

CAVI TIPO "Li-YCY-P"
A COPPIE SCHERMATI A TRECCIA

CABLES TYPE "Li-YCY-P"
TWISTED PAIRS, TINNED COPPER BRAID SHIELD

PROVA N.P. FIAMMA:
Standard: sec. CEI 20-35 (IEC 332.1)
A richiesta: sec. CEI 20-22 II (IEC 332.3A)



FLAME RETARDANT TEST:
Standard: CEI 20-35 (IEC 332.1) Ref.
On request: CEI 20-22 II (IEC 332.3A) Ref.

IMPEDENZA DI TRASFERIMENTO:
max 200 mohm/m (f<10MHz)



SURFACE TRANSFER IMPEDANCE:
max 200 mohm/m (f<10MHz)

CAPACITA' DI LAVORO:
cond/cond: 120 nF/km (nom.)
cond/sch: 180 nF/km (nom.)



CAPACITANCE:
cond/cond: 120 nF/km (nom.)
cond/shield: 180 nF/km (nom.)

CODICE	FORMAZIONE	ø esterno medio	Peso medio Kg/Km	CODICE	FORMAZIONE	ø esterno medio	Peso medio Kg/Km
CODE	TYPE	outer diameter ø	Medium weight Kg/Km	CODE	TYPE	outer diameter ø	Medium weight Kg/Km
28.204.1.02.1.000	2x2x0.14	5.6	40.0	28.204.1.02.4.000	2x2x0.34	7.3	68.0
28.204.1.03.1.000	3x2x0.14	5.9	47.0	28.204.1.03.4.000	3x2x0.34	7.8	82.0
28.204.1.04.1.000	4x2x0.14	6.2	61.0	28.204.1.04.4.000	4x2x0.34	8.6	96.0
28.204.1.05.1.000	5x2x0.14	7.2	68.0	28.204.1.05.4.000	5x2x0.34	10.0	110.0
28.204.1.06.1.000	6x2x0.14	7.6	76.0	28.204.1.06.4.000	6x2x0.34	10.6	130.0
28.204.1.07.1.000	7x2x0.14	7.6	82.0	28.204.1.07.4.000	7x2x0.34	10.6	145.0
28.204.1.08.1.000	8x2x0.14	8.4	90.0	28.204.1.08.4.000	8x2x0.34	11.5	150.0
28.204.1.10.1.000	10x2x0.14	9.8	118.0	28.204.1.10.4.000	10x2x0.34	13.0	190.0
28.204.1.12.1.000	12x2x0.14	10.2	130.0	28.204.1.12.4.000	12x2x0.34	13.5	220.0
28.204.1.16.1.000	16x2x0.14	11.2	160.0	28.204.1.16.4.000	16x2x0.34	15.2	250.0
28.204.1.18.1.000	18x2x0.14	11.7	186.0	28.204.1.18.4.000	18x2x0.34	16.0	275.0
28.204.1.20.1.000	20x2x0.14	12.4	200.0	28.204.1.20.4.000	20x2x0.34	17.1	290.0
28.204.1.25.1.000	25x2x0.14	14.0	273.0	28.204.1.25.4.000	25x2x0.34	19.5	400.0
28.204.1.02.3.000	2x2x0.25	5.8	54.0	28.204.1.02.5.000	2x2x0.50	7.6	75.0
28.204.1.03.3.000	3x2x0.25	7.0	65.0	28.204.1.03.5.000	3x2x0.50	9.0	125.0
28.204.1.04.3.000	4x2x0.25	7.3	89.0	28.204.1.04.5.000	4x2x0.50	10.0	140.0
28.204.1.05.3.000	5x2x0.25	8.0	99.0	28.204.1.05.5.000	5x2x0.50	10.8	160.0
28.204.1.06.3.000	6x2x0.25	9.0	114.0	28.204.1.06.5.000	6x2x0.50	11.7	190.0
28.204.1.07.3.000	7x2x0.25	9.0	120.0	28.204.1.07.5.000	7x2x0.50	11.7	220.0
28.204.1.08.3.000	8x2x0.25	9.6	126.0	28.204.1.08.5.000	8x2x0.50	14.0	250.0
28.204.1.10.3.000	10x2x0.25	10.3	160.0	28.204.1.10.5.000	10x2x0.50	15.0	300.0
28.204.1.12.3.000	12x2x0.25	11.4	171.0	28.204.1.12.5.000	12x2x0.50	15.7	345.0
28.204.1.16.3.000	16x2x0.25	13.1	238.0	28.204.1.16.5.000	16x2x0.50	17.6	450.0
28.204.1.18.3.000	18x2x0.25	13.6	248.0				
28.204.1.20.3.000	20x2x0.25	14.2	275.0				
28.204.1.25.3.000	25x2x0.25	16.4	340.0				

CAVI TIPO "Li-ICY-P"
A COPPIE SCHERMATI A TRECCIA

CABLES TYPE "Li-ICY-P"
TWISTED PAIRS, TINNED COPPER BRAID SHIELD

CODICE	FORMAZIONE	ø esterno medio	Peso medio Kg/Km	CODICE	FORMAZIONE	ø esterno medio	Peso medio Kg/Km
CODE	TYPE	outer diameter ø	Medium weight Kg/Km	CODE	TYPE	outer diameter ø	Medium weight Kg/Km
28.204.1.02.6.000	2x2x0.75	8.6	103.0	28.204.1.02.7.000	2x2x1	9.4	122.0
28.204.1.03.6.000	3x2x0.75	9.0	128.0	28.204.1.03.7.000	3x2x1	11.5	179.0
28.204.1.04.6.000	4x2x0.75	10.6	167.0	28.204.1.04.7.000	4x2x1	12.8	237.0
28.204.1.05.6.000	5x2x0.75	12.0	215.0	28.204.1.05.7.000	5x2x1	13.8	297.0
28.204.1.06.6.000	6x2x0.75	12.8	240.0				
28.204.1.07.6.000	7x2x0.75	12.8	265.0				
28.204.1.08.6.000	8x2x0.75	14.6	306.0				
28.204.1.10.6.000	10x2x0.75	16.0	355.0				
28.204.1.12.6.000	12x2x0.75	17.0	405.0				
28.204.1.16.6.000	16x2x0.75	20.5	565.0				

Addendum 4: LMV52... with O2 trim control and O2 module

General

The LMV52... system is an extended LMV51... system. A special feature of the LMV52... is control of the residual oxygen content to increase the boiler's efficiency.

In addition to the features of the LMV51..., the LMV52... provides O2 trim control, control of a maximum of 6 actuators, control of a VSD, and acquisition of cumulated fuel consumption and current fuel throughput. The LMV52... system uses an O2 sensor (QGO20...), an external O2 module, and the standard components of the LMV51... system.

ATTENTION: for the proper burner adjustment, it is necessary to install a fuel meter for each burner.

The PLL... O2 module is a detached measuring module for the QGO20... sensor and for 2 temperature sensors (Pt1000 / LG-Ni 1000). The module communicates with the LMV52... via CAN bus.

The fuel meters must be connected directly to the fuel-related inputs of the basic unit. On the AZL5... display and operating unit, the individual consumption values can be read out and the meter readings can be reset.

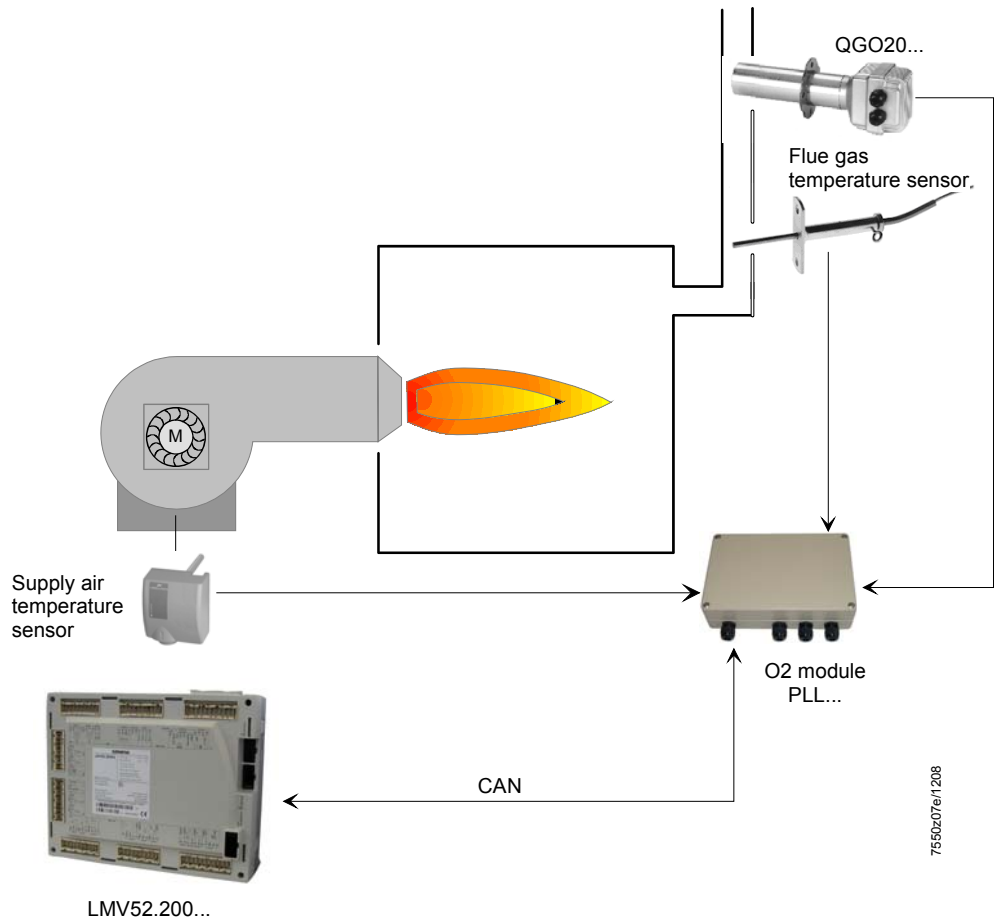

Determination of the maximum cable length

The maximum cable length between transformer and CAN bus users is dependent on the type of cable (cross-sectional area), the number of actuators and the type of actuator used (current).

The following graphs can be used to determine the maximum CAN bus cable lengths between the transformer and group of actuators or the AZL5..., depending on the relevant influencing factors.

The assumption was made that the actuators within the group are close to one another. The **minimum** cross-sectional area for the system examples shown results from the start of the curve.

The **maximum** cable lengths for the defined system cables AGG5.641 and AGG5.631 result from the points of intersection in the graph.

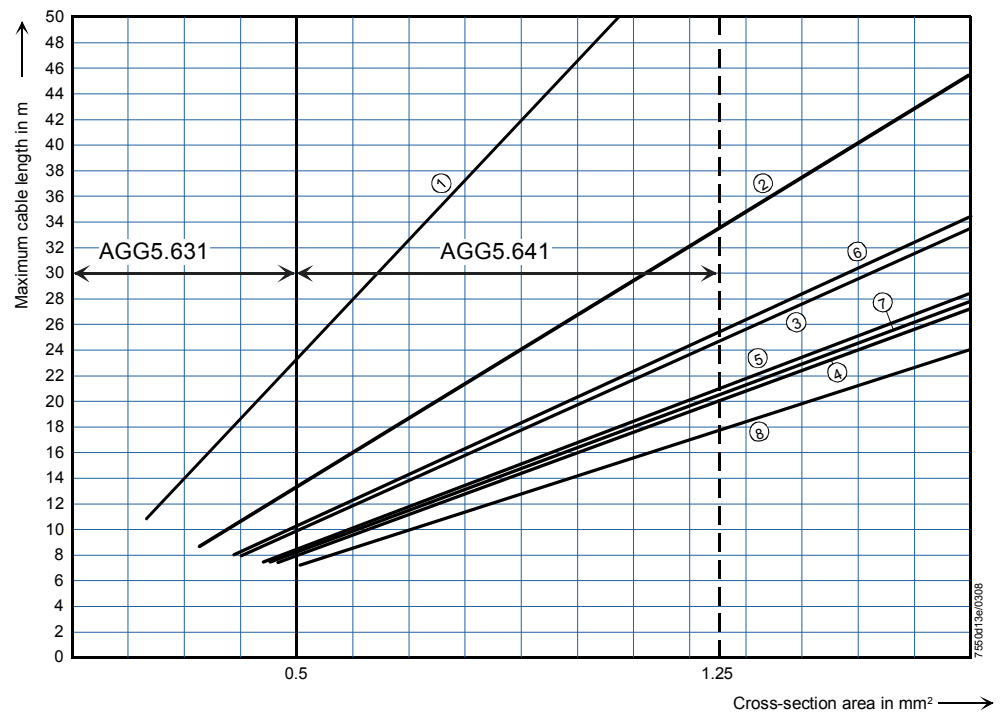

AGG5.631 (cable type 2)
AGG5.641 (cable type 1)

- | | |
|----------------|-------------------------------|
| ① 1 x SQM45... | ⑤ 2 x SQM48... |
| ② 2 x SQM45... | ⑥ 1 x SQM45... + 1 x SQM48... |
| ③ 3 x SQM45... | ⑦ 2 x SQM45... + 1 x SQM48... |
| ④ 4 x SQM45... | ⑧ 3 x SQM45... + 1 x SQM48... |

CAN bus connection between transformer and actuator group



When connecting a PLL52... O2 module, the maximum permissible cable length of a network is to be reduced by 2 m.

Example: - System cable: AGG5.641 (connecting cable to the actuators)
- Actuators: 2 x SQM45...

The point of intersection of the vertical line for the AGG5.641 (1.25 mm²) and curve ① (2 x SQM45...) gives a maximum cable length of 33.4 m between the transformer and the group of actuators.

Example 1

**Installation of all components in the burner;
CAN bus cable «LMV5... →shielding last actuator» 20 m**

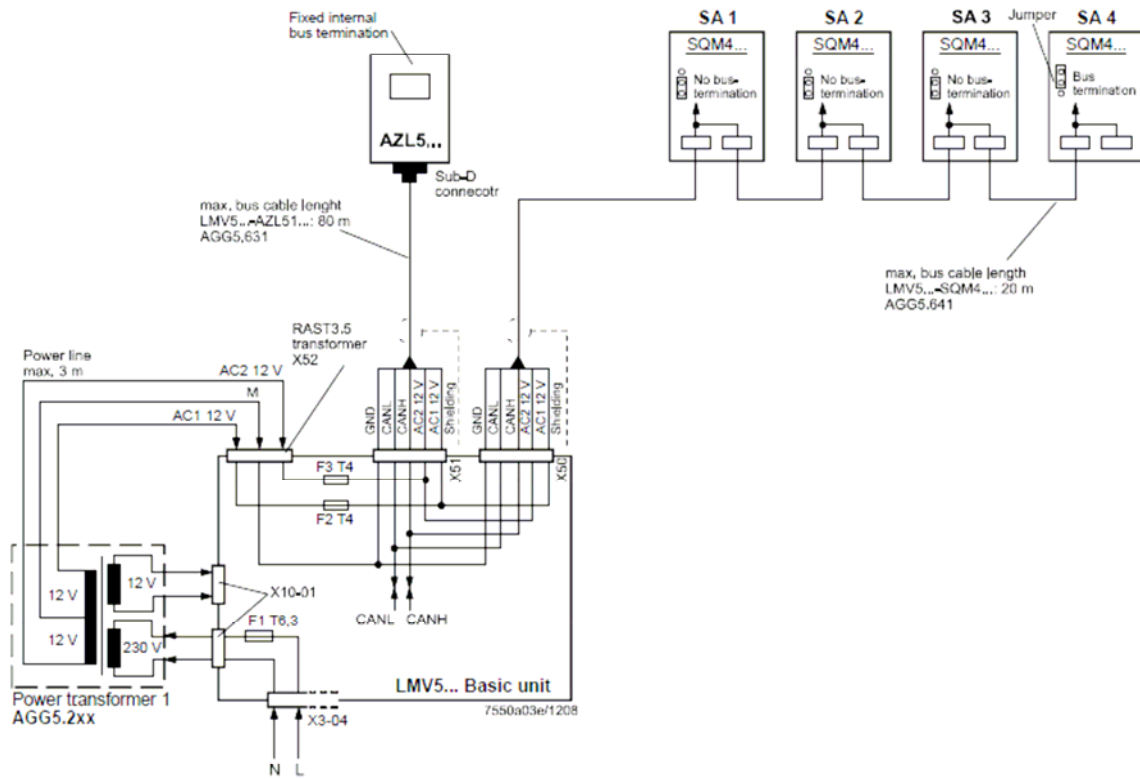

Note on example 1

Total length of CAN bus cable ≤ 100 m

Example 2

**LMV5... basic unit in the control panel, actuator on the burner;
CAN bus cable «LMV5... → SA» > 20 m**

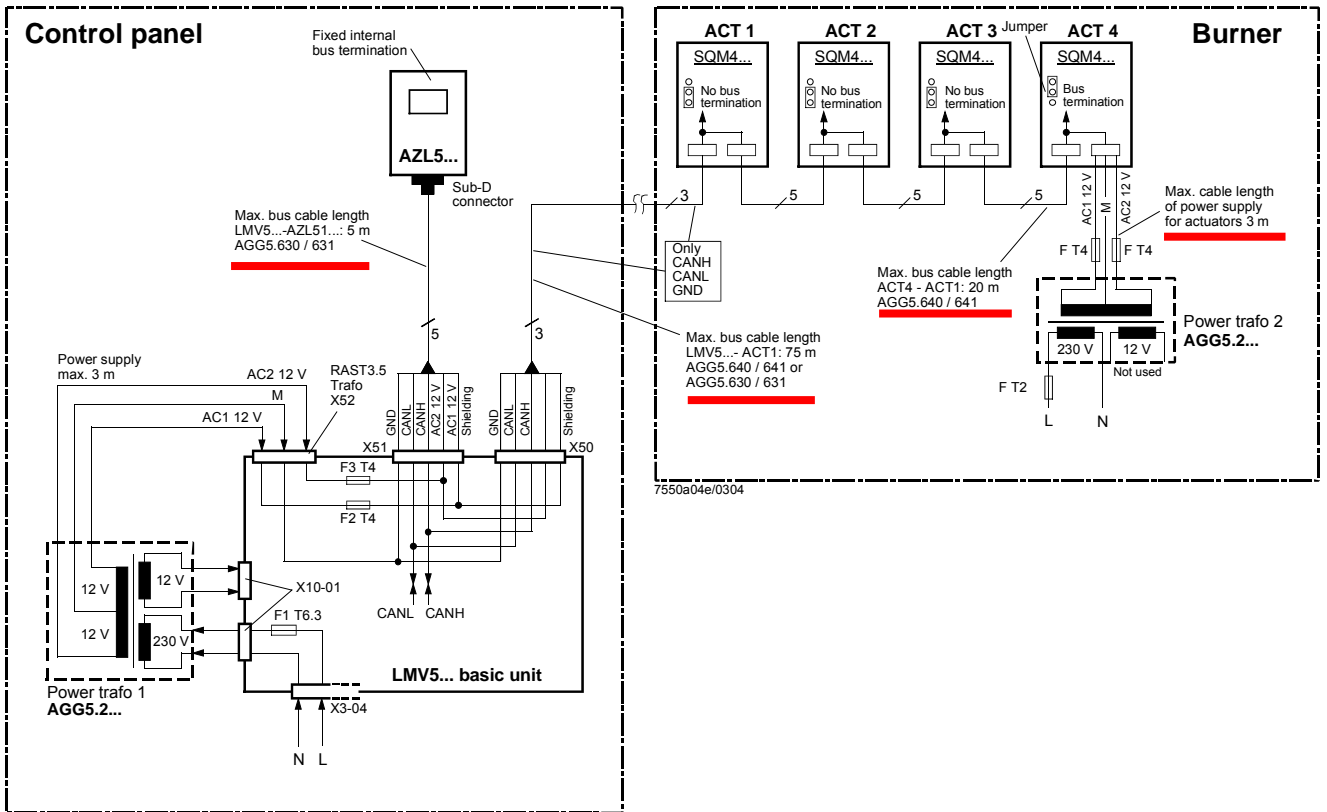

Notes on example 2

Total length of CAN bus cable ≤ 100 m

Whenever the distance between the LMV5... and the last actuator exceeds 20 m, or if more than one SQM48 is used on the burner (refer to sizing chart “Determination of maximum cable length”), a second transformer is required for powering the actuators.

In that case, transformer 1 powers the LMV5... basic unit and the AZL5... display and operating unit (**Fig. 1**). Transformer 2 powers the actuators (**Fig. 2**).



With the CAN bus cable connections from the LMV5... (**Fig. 1**) to the first actuator (**Fig. 2**), the 2 voltages AC1 and AC2 on the LMV5... side must **not** be connected and only cables CANH, CANL and M (+shielding) are to be connected to the first actuator (**Fig. 2**).

In that case, the actuators must be powered by a second transformer which to be located near the actuators.

The power from that transformer (lines AC1, AC2, M) must be fed to the actuator (ACT4 in the example above) and then connected through via bus cable AGG5.640 (cable type 1) to all the other actuators.

The fuses required for transformer 1 are accommodated in the LMV5... basic unit.



For transformer 2, these 3 fuses must be located close to the transformer (for type, refer to Basic Documentation P7550).

Example 3a

**Installation of all components in the burner;
CAN bus cable «LMV52... ↔ SA» > 20 m with 6 actuators and O2 module
PLL52...**

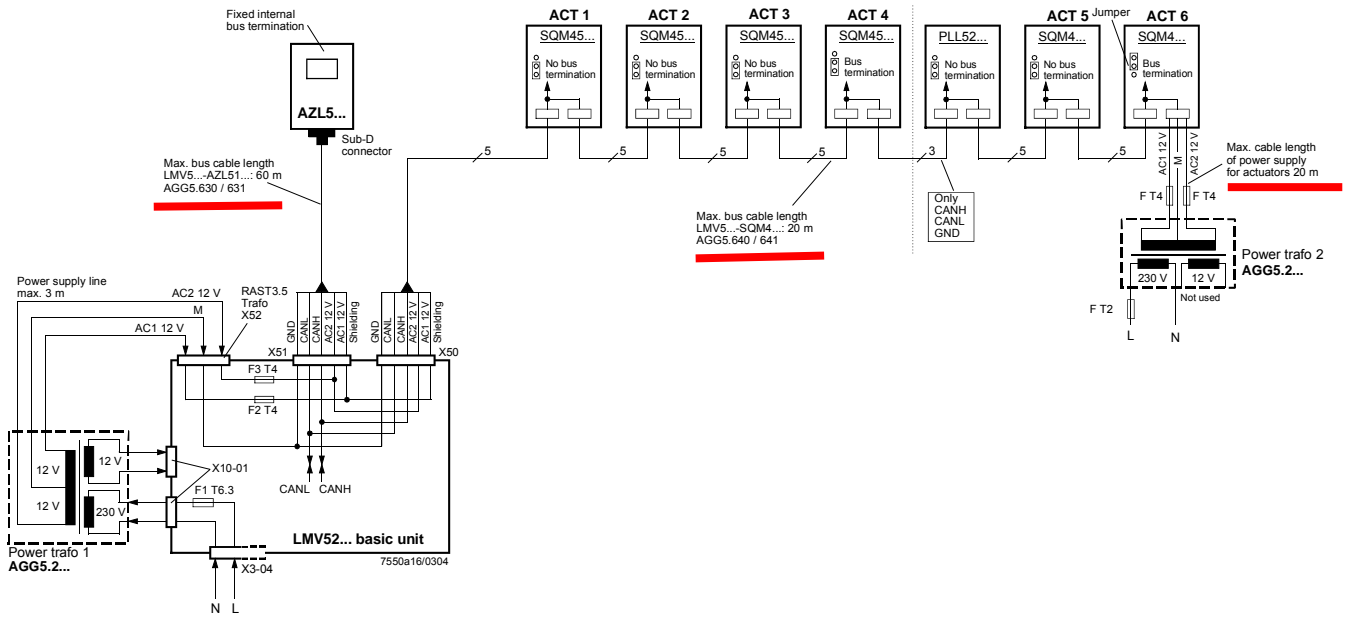

Example 3b

**Installation in the control panel, actuator on the burner;
CAN bus cable «LMV52... ↔ SA» > 25 m with 4 actuators and O2 module
PLL52...**

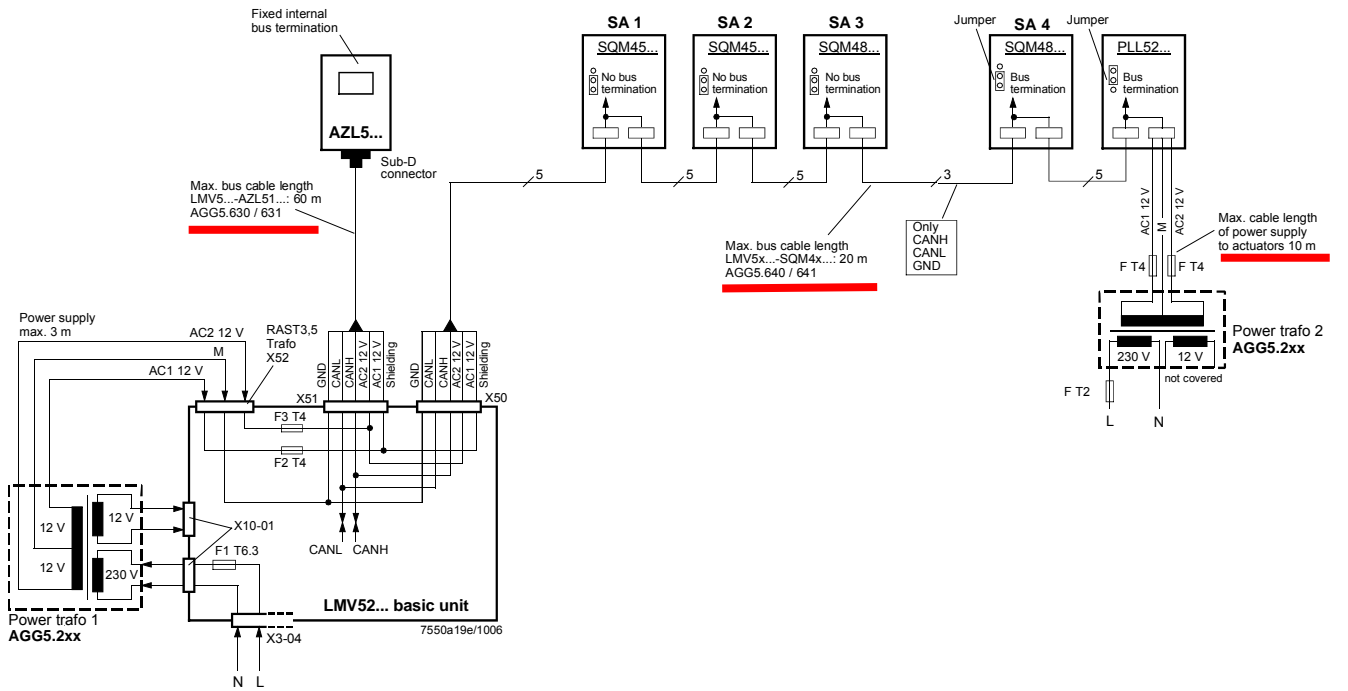

On LMV52... applications with more than 4 actuators (SQM45...), a second transformer is required for powering the extra actuators.

In that case, transformer 1 powers the LMV52... basic unit, the **AZL5...**, and the first 4 actuators.



Interrupt the connection between the components at a suitable location. On the actuator side, the 2 voltages AC1 and AC2 must **not** be connected but only lines «CANH, CANL and M» (+shield) to the O2 module and the other actuator.

In that case, the actuators (SA5, SA6) and the O2 module must be powered by a second transformer to be located near the actuators and the O2 module.

Connect the power supply line from that transformer to the O2 module PLL52... (in example 3a «SA6» / in example 3b «Auxiliary terminal») (lines AC1, AC2, M) and from there, via bus cable AGG5.640 (cable type 1), through to the second actuator (SA) and the O2 module.

The fuses required for transformer 1 are accommodated in the LMV52... basic unit.

Optionally, the supply voltage can also be delivered via a conduit box and fed into the connecting line between SA4 and PLL52...

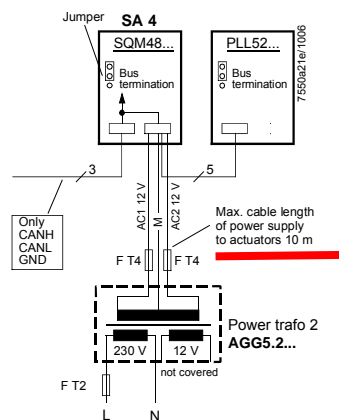

For transformer 2, the OEM must fit the 3 fuses close to the transformer.

O2 module

In comparison with the LMV51... system, the extra components to be connected with the LMV52... system are the O2 module and the O2 sensor QGO... and, optionally, the combustion air and flue gas temperature sensors. The O2 module is to be connected to the basic unit via the CAN bus. The O2 module must be located in the vicinity of the QGO... (< 10 m), aimed at keeping interference on the sensitive detector lines as low as possible. For sensor heating, the O2 module requires a separate mains connection facility.

18.8.1 Inputs and outputs

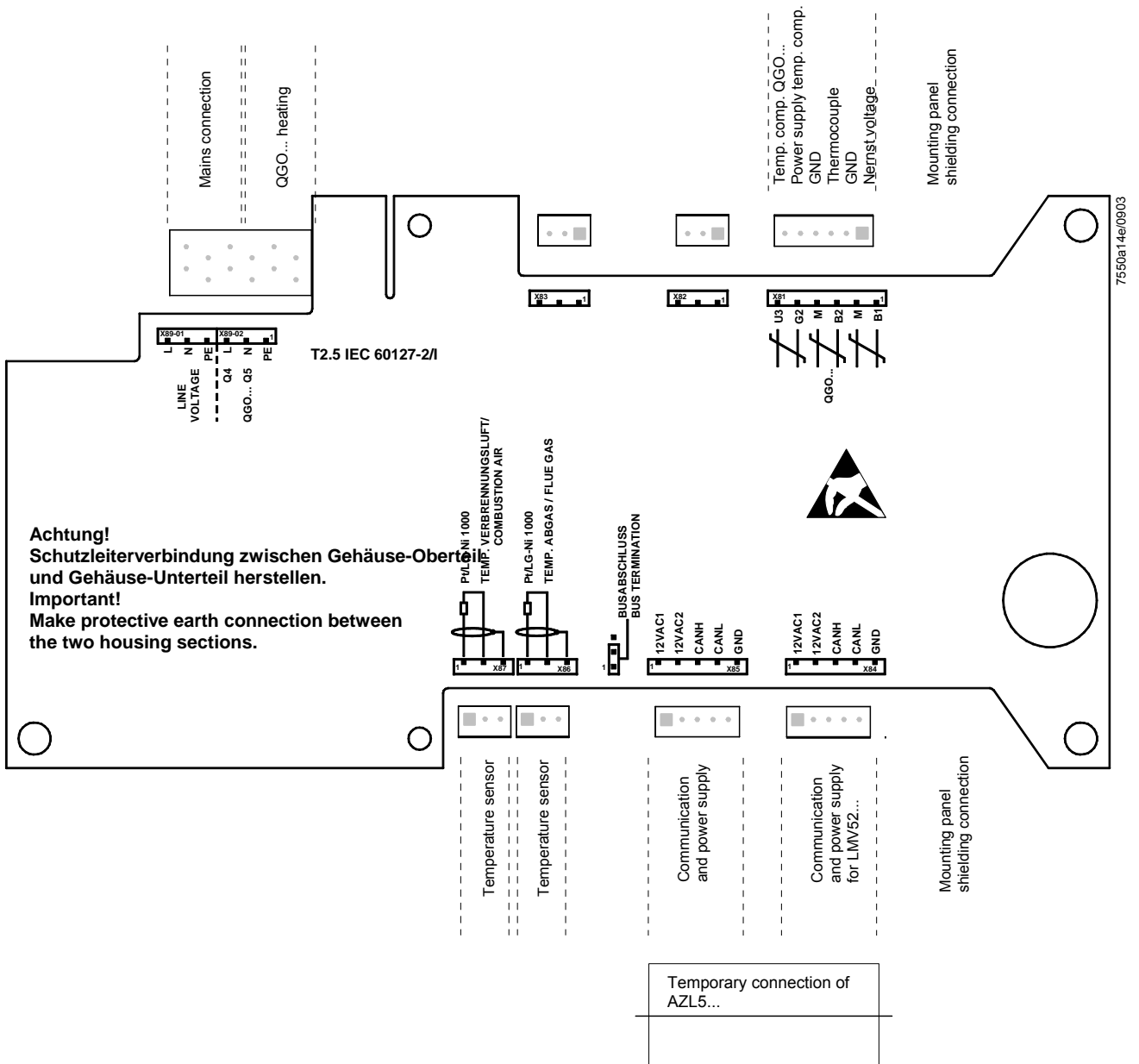

7550a14e/0903

QGO20...

Montageanleitung
 Mounting instruction
 Instruction de montage
 Monteringsanvisning
 Montage-aanwijzing

Istruzioni di montaggio
 Asennusohje
 Instrucciones de montaje
 Monteringsinstruktion
 Montasjeanvisning



7842mb01/1200

Fühler aus Keramik - zerbrechlich
 Ceramic detector - fragile
 Sonde en céramique - fragile

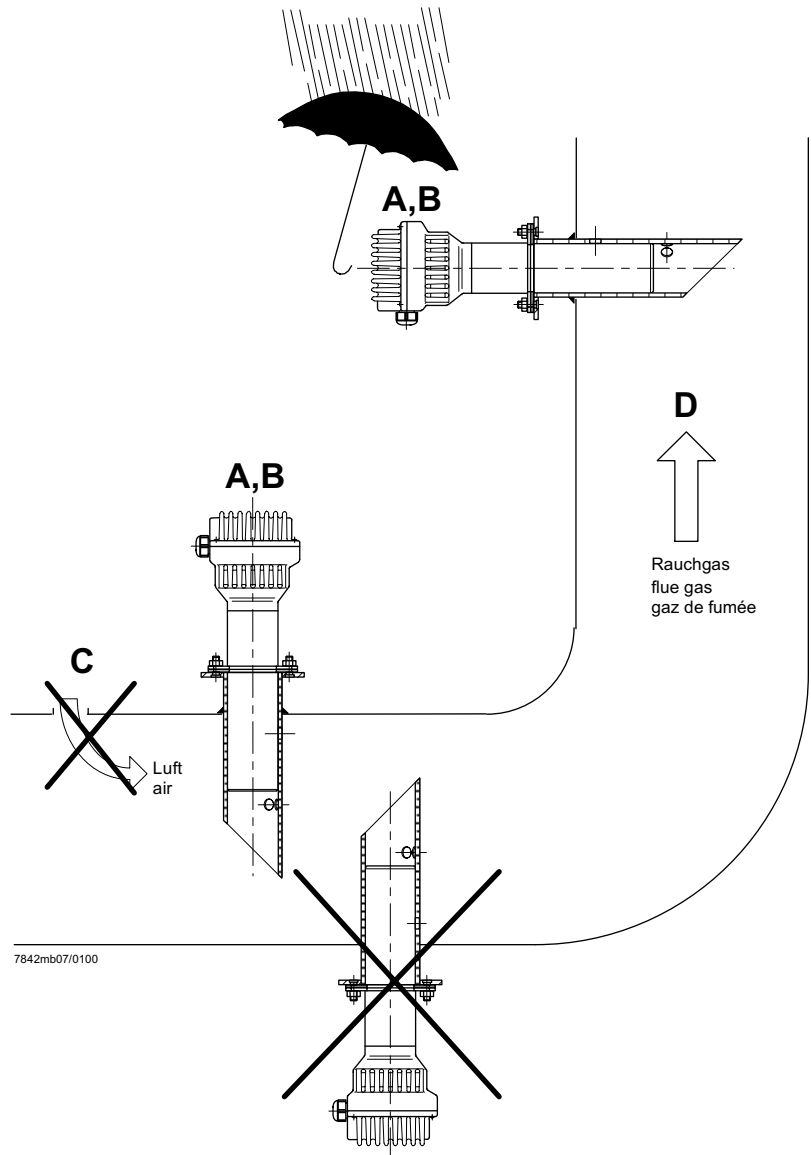

7842mb07/0100

O₂-Fühler QGO20... und Rauchgassammler AGO20...

Voraussetzungen für eine korrekte messtechnische Erfassung des O₂-Gehaltes der Rauchgase:

A - QGO20... **nur** mit Rauchgassammler AGO20... einsetzen

B - Einbauort des QGO20... so nahe am Brenner wie möglich, in einem Bereich ohne Turbulenzen und Inhomogenitäten. Nicht direkt im Bereich von Klappen oder Bögen montieren. Idealer Abstand: 5 x Kamindurchmesser.

C - Zwischen Brenner und Fühler darf keine Luft in die Rauchgase gelangen.

D - Strömungsgeschwindigkeit 1...10 m/s. Rauchgastemperatur am Messort ≤ 300°C

O₂-detector type QGO20... and flue gas collector type AGO20...

Presupposition for the correct measurement of the O₂ content of the flue gases:

A - Use QGO20... **only** with flue gas collector type AGO20...

B - Mounting position of the QGO as close as possible to the burner, in a homogenous area without any turbulences. Do not mount the QGO20... in the area of dampers or curves. Ideal distance: Five times the diameter of the stack.

C - No air must be allowed to join the flue gases on their way from the burner to the detector.

D - Flow velocity 1...10 m/s. Flue gas temperature at the measuring position ≤ 300°C

Sonde O₂ QGO20... et collecteur des gaz de fumée AGO20...

Conditions requises pour une détection correcte de la teneur en O₂ des gaz de fumée:

A - Utiliser le QGO20... **exclusivement** avec le collecteur des gaz de fumée AGO20...

B - Lieu de montage du QGO20... le plus près possible du brûleur, dans un domaine homogène sans turbulences. Ne pas le monter dans le domaine des clapets ou dans les courbes. Distance idéale: Cinq fois le diamètre de la cheminée.

C - Entre le brûleur et la sonde, il ne doit pas pénétrer d'air dans les gaz de fumée.

D - Vitesse d'écoulement 1...10 m/s. Température des gaz fumée au lieu de la mesure ≤ 300°C

Anschluss-Schema

6-adriges abgeschirmtes Kabel. Adern möglichst paarweise verdreht. Abschirmung an Klemme GND des RPO... . Abschirmung nicht mit Schutzleiter oder M verbinden!

Anschlusskabel z.B.:

LifYCY 6 x 2 x 0,20 / 22 oder
LiYCY 6 x 2 x 0,20

B1 (+)	Signal O ₂ -Messzelle
M (-)	Masse für B1, B2
B2 (+)	Thermoelement-Spannung
M (-)	
U3 (+)	Signal Temperaturkompensations- element
G2 (-)	Speisung Temperaturkompensations- element
GND	Masse für Anschirmung
3 x 1,5 mm ² :	
Q4	Fühlerheizung (AC 230 V)
Q5	Fühlerheizung (AC 230 V)

⏏ Erde*



Vorsicht bei den Anschlüssen U3 und G2!
Ein Fehlverdrahten der Anschlüsse führt zu einem Ausfall des Kompensationselementes.

* Am RPO... steht nur 1 Erdleiterklemme zur Verfügung. Beide Erdleiter müssen auf **eine** Klemme geführt werden.

Wiring diagram

Shielded 6-core cable. Wires should be twisted in pairs. Screen must be connected to terminal GND of the RPO... . Do not connect the shielding to the protective earth or M!

Connecting cable e.g.:

LifYCY 6 x 2 x 0,20 / 22 or
LiYCY 6 x 2 x 0,20

B1 (+)	Signal from O ₂ -measuring cell
M (-)	Ground for B1, B2
B2 (+)	Thermocouple voltage
M (-)	
U3 (+)	Signal from temperature compensation element
G2 (-)	Power supply for temperature compensation element
GND	Ground for screening
3 x 1,5 mm ² :	
Q4	QGO... detector heating (AC 230 V)
Q5	QGO... detector heating (AC 230 V)

⏏ Earth*



Caution when connecting U3 and G2!
Faulty wiring leads to failure of the compensation element.

* At the RPO..., there is only 1 earth terminal available. Both earth wires must be connected to **the same** earth terminal.

Schéma de raccordement

Câble blindé à 6 brins. Brins torsadés si possible par paires. Blindage sur la borne GND du RPO... . Ne pas connecter le blindage avec le conducteur de protection ou M!

Câble de raccordement p.ex.:

LifYCY 6 x 2 x 0,20 / 22 ou
LiYCY 6 x 2 x 0,20

B1 (+)	Signal de la cellule de mesure d'O ₂
M (-)	Masse pour B1, B2
B2 (+)	Tension de thermocouple
M (-)	
U3 (+)	Signal de l'élément de compensation de température
G2 (-)	Alimentation de l'élément de compensation de température
GND	Masse du blindage
3 x 1,5 mm ² :	
Q4	Chauffage de sonde QGO... (AC 230 V)
Q5	Chauffage de sonde QGO... (AC 230 V)

⏏ Terre*



Prière de faire attention lors des raccordements U3 et G2. Une erreur de câblage des fils de raccordement conduit à une destruction de l'élément de compensation.

* Le RPO... ne dispose que d'une seule borne de mise à la terre. Les deux fils de mise à la terre doivent être connectés sur **la même** borne.

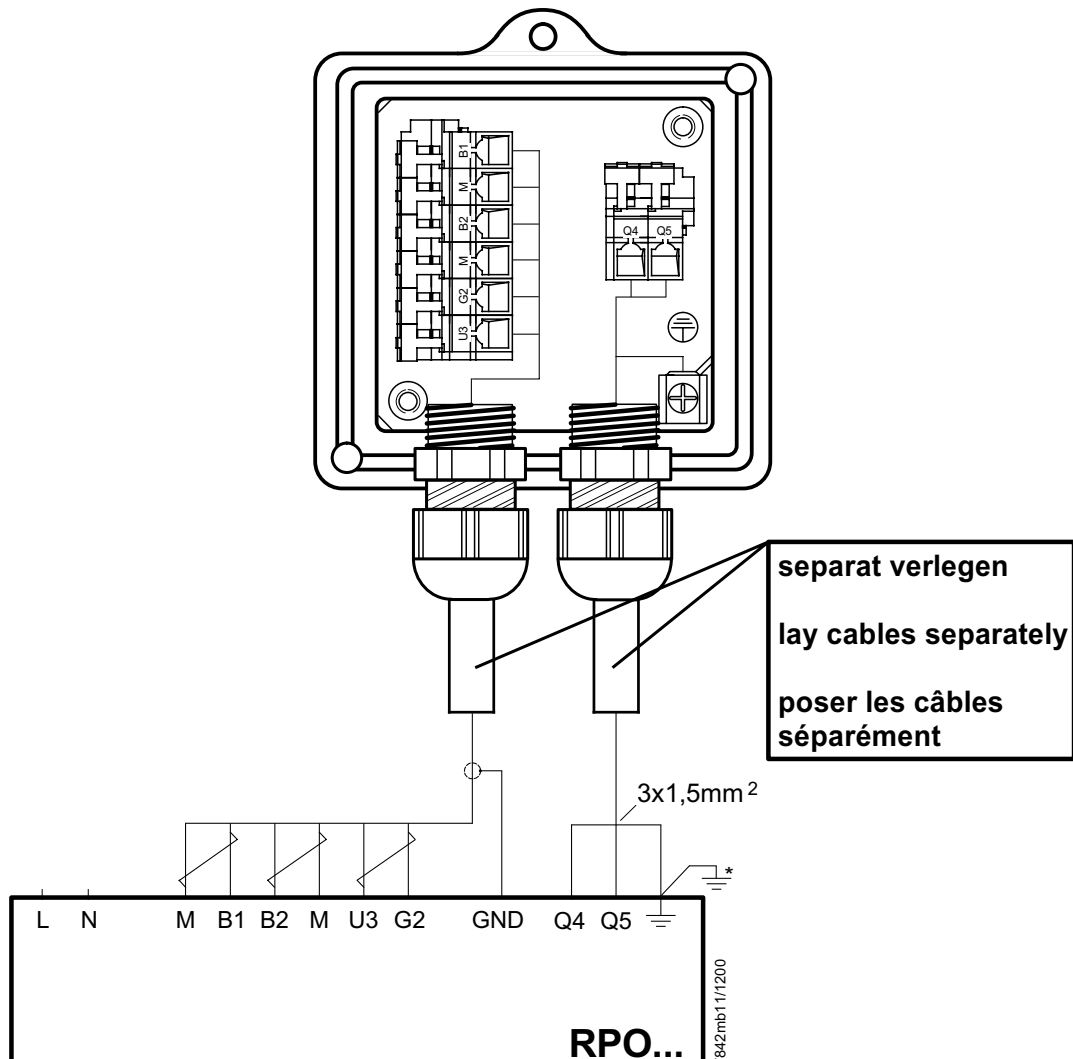

Hinweise für Installation und Inbetriebnahme

- Distanz zwischen Wand des Rauchgaskanals und Rauchgasaustritt (B) des AGO20... min. 10 mm
- Die Kaminisolierung darf nicht über den Anschlussflansch hinausragen und dadurch den Fühlerkopf isolieren (therm. Überlastung). Der Fühlerkopf muss frei bleiben! Strahlungswärme vermeiden; z.B. durch Wärmeleitbleche
- Bei der ersten Inbetriebnahme ist das Mess-System ca. 2 Stunden vor Gebrauch einzuschalten. Bei kurzen Abschaltungen der Anlage (1-2 Wochen) ist es empfehlenswert, das Mess-System (QGO... und RPO) nicht auszuschalten.
- Während des Aufheizvorganges kann der Fühler falsch messen.



- QGO20... nie im kalten Zustand bei laufendem Brenner im Kamin einsetzen.
- Nach Fühlertausch, Ansteuerung der Fühlerheizung überprüfen.
- Spannung an Q4 - Q5 muss im 2 s Takt pulsieren.
- **Sofort ausschalten** falls Spannung nicht pulsieret
 ↳ RPO austauschen

Commissioning and Installation Guide

- The distance between the wall of the flue gas duct and the flue gas outlet (B) of the AGO20... must be a minimum of 10 mm
- The insulation of the chimney must not project beyond the connecting flange, thus insulating the head of the sensor (thermal overload). The head of the sensor must remain uncovered! Avoid heat due to radiation, e.g. through thermal conductive plates
- When starting up the plant for the first time, the measuring system should be switched on approx. 2 hours prior to usage. If the plant is switched off for short periods of the time (1 to 2 weeks), it is recommended to leave the measuring system (QGO... and RPO) switched on.
- During the heating up phase, the detector could deliver an incorrect signal.



- Never use a cold QGO20... in the flueway while burner is operating.
- After changing the sensor, check the proper functioning of the sensor's heating element
- Voltage at Q4 - Q5 must pulsate at 2-s intervals
- If voltage does not pulsate, **switch equipment off immediately**
 ↳ replace RPO

Instructions de mise en service et installation

- La distance entre la paroi de la conduite de gaz et la sortie des gaz de fumée (B) du AGO20... doit être d'au moins 10 mm.
- L'isolation de la cheminée ne doit pas dépasser la bride de raccordement, c'est-à-dire couvrir la tête de la sonde (surcharge thermique). La tête de la sonde ne doit pas être couverte! Éviter la chaleur de rayonnement, p.ex. par tôles thermoconductrices
- Lors de la première mise en service, le dispositif de mesure doit être raccordé environ 2 heures avant l'utilisation. En cas de courtes interruptions de l'installation (1-2 semaines), il est recommandé de ne pas déclencher le dispositif de mesure (QGO... et RPO).
- Pendant l'opération d'échauffement, il est possible que la sonde ne mesure pas correctement.



- Ne jamais introduire le QGO20... à l'état froid ou le laisser introduit dans la cheminée quand le brûleur est en marche.
- Lors d'un changement de sonde, vérifier le signal de chauffage de celle-ci.
- Les tensions aux bornes Q4 - Q5 doivent commuter toutes les 2 s.
- **Déconnecter immédiatement** en cas de non-commutation des tensions
 ↳ Echanger le RPO

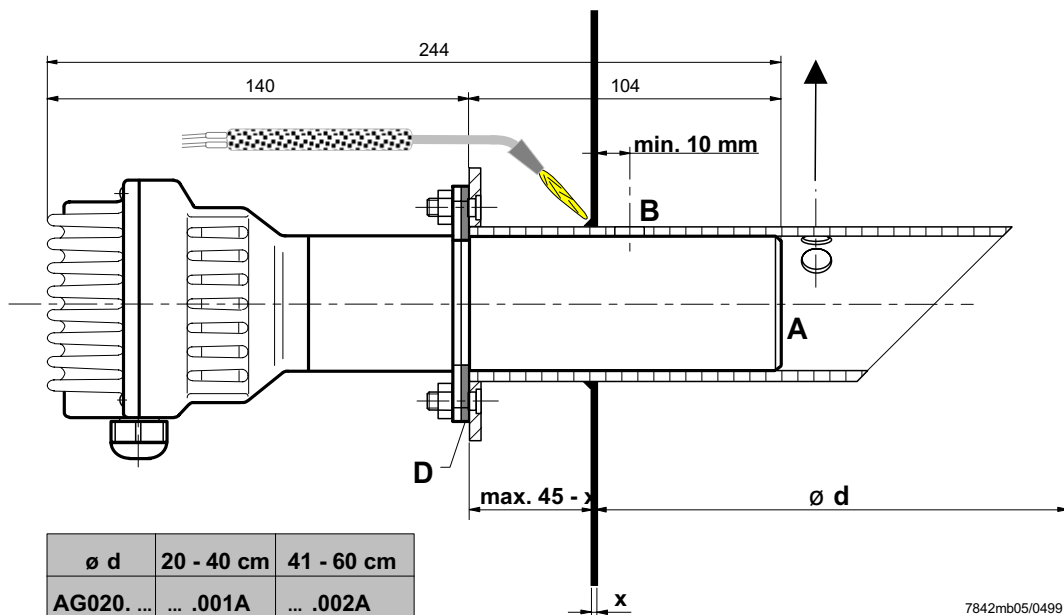

7842mb05/0499

Kerben beachten!
Observe notches!
Attention aux entailles!

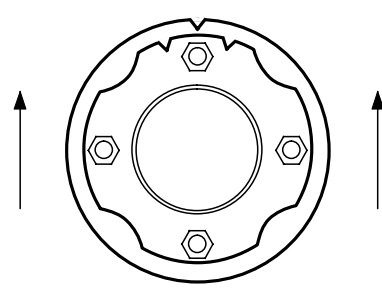

7842mb06/0499

Legende:
 Strömungsrichtung
 Direction of flow of flue gases
 Direction du courant des gaz de fumée

Maßbilder / Dimensions / Encombrements

QGO20...

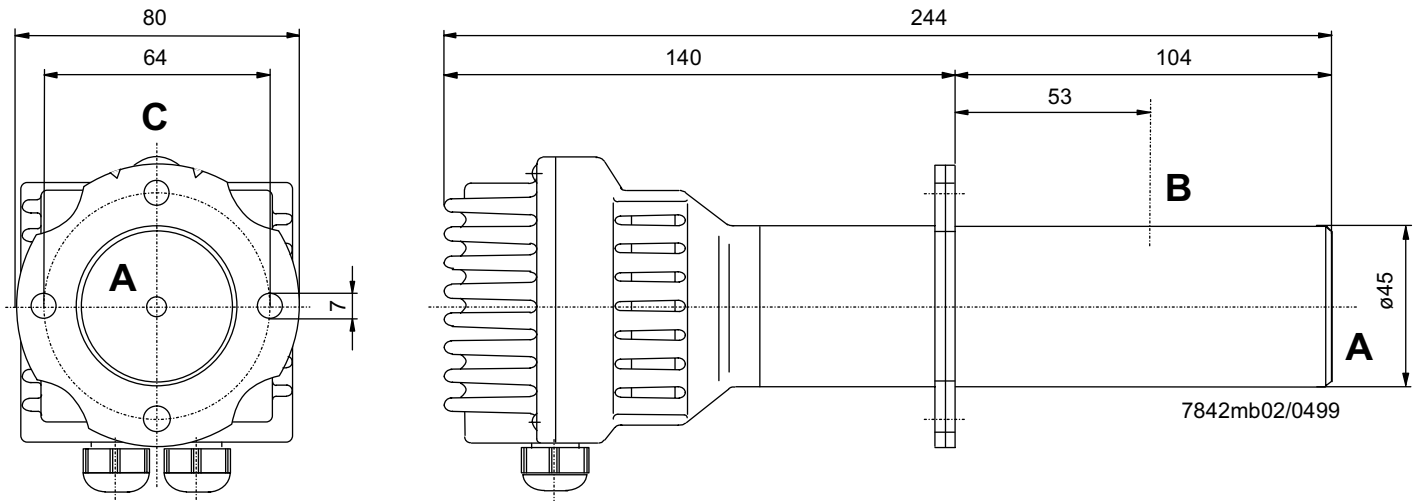

AGO20...

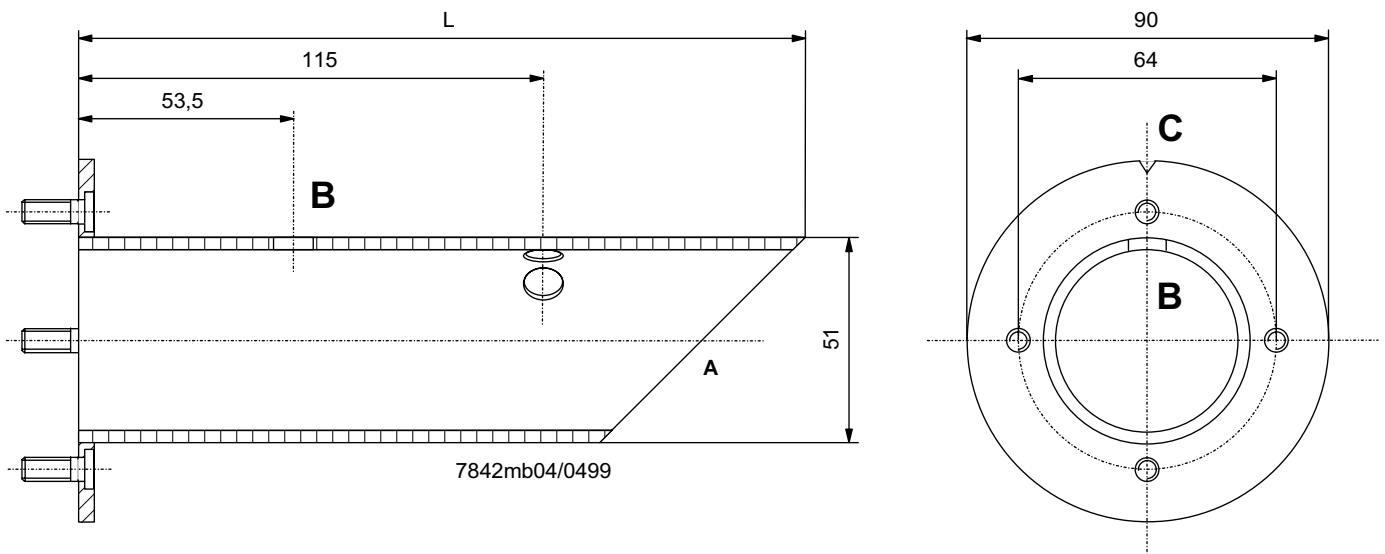

L = 180 mm für AGO20.001A
L = 260 mm für AGO20.002A

A = Rauchgaseintritt
B = Rauchgasaustritt
C = Kerbe
D = Flachdichtung (beiliegend)

L = 180 mm for AGO20.001A
L = 260 mm for AGO20.002A

A = Flue gas inlet
B = Flue gas outlet
C = Notch
D = Flat seal (enclosed)

L = 180 mm pour AGO20.001A
L = 260 mm pour AGO20.002A

A = Entrée du gaz de fumée
B = Sortie de gaz de fumée
C = Entaille
D = Joint d'étanchéité plat (inclus)

Technical Data PLL52...

LMV52... basic unit

Refer to chapter *Technical Data!*

PLL52...

Mains voltage «X89-01»	AC 120 V -15 % / +10 %	AC 230 V -15 % / +10 %
Safety class	I with parts according to II as per DIN EN 60730-1	
Mains frequency	50 / 60 Hz ±6 %	
Power consumption	Ca. 4 VA	Ca. 4 VA
Degree of protection	IP54, housing closed	
Transformer AGG5.210		
- Primary side	AC 120 V	
- Secondary side	AC 12 V (3x)	
Transformer AGG5.220		
- Primary side	AC 230 V	
- Secondary side	AC 12 V (3x)	

Environmental conditions

Storage	DIN EN 60 721-3-1
Climatic conditions	class 1K3
Mechanical conditions	class 1M2
Temperature range	-20...+60 °C
Humidity	< 95 % r.h.
Transport	DIN EN 60 721-3-2
Climatic conditions	class 2K2
Mechanical conditions	class 2M2
Temperature range	-30...+70 °C
Humidity	< 95 % r.h.
Operation	DIN EN 60 721-3-3
Climatic conditions	class 3K5
Mechanical conditions	class 3M2
Temperature range	-20...+60 °C
Humidity	< 95 % r.h.



Condensation, formation of ice or ingress of water are not permitted!

Terminal ratings, cable lengths and cross-sectional areas

LMV52... basic unit

Refer to chapter «Technical Data / LMV5... and AZL5...!»

PLL52...

Cable lengths / cross-sectional areas	
Electrical connection «X89»	Screw terminals up to max. 2.5 mm ²
Cable lengths	≤10 m to QGO20...
Cross-sectional areas	Refer to description of QGO20... Twisted pairs

Analog inputs:

Fresh air temperature detector	Pt1000 / LG-Ni1000
Flue gas temperature detector	Pt1000 / LG-Ni1000
QGO20...	Refer to Data Sheet N7842
Interface	Communication bus for LMV52...

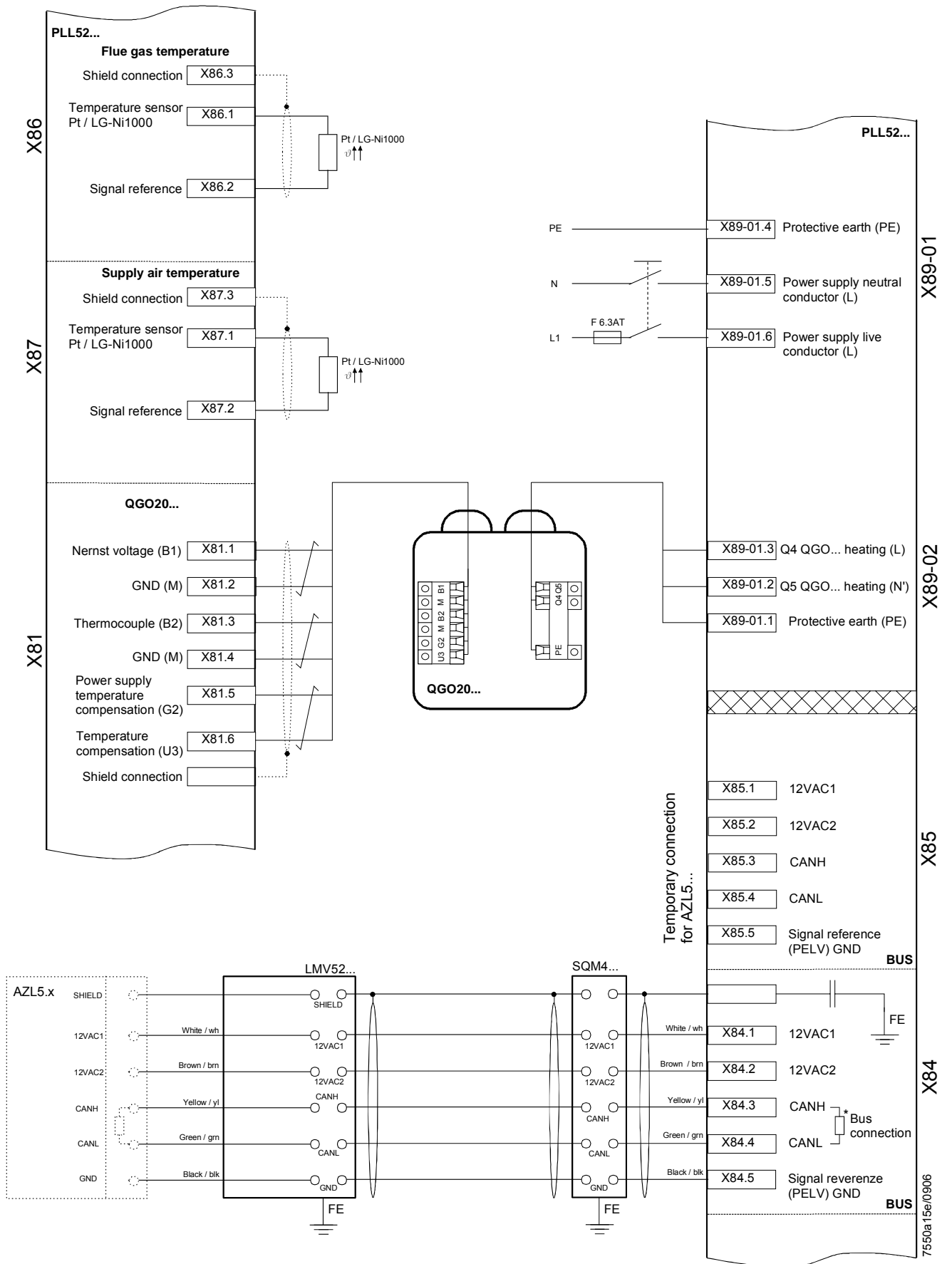

KOSTAL INVERTER

Connection and programming
for electronically controlled burners with

**LMV2x/3x, LMV5x, ETAMATIC
and INVERTER regulation**

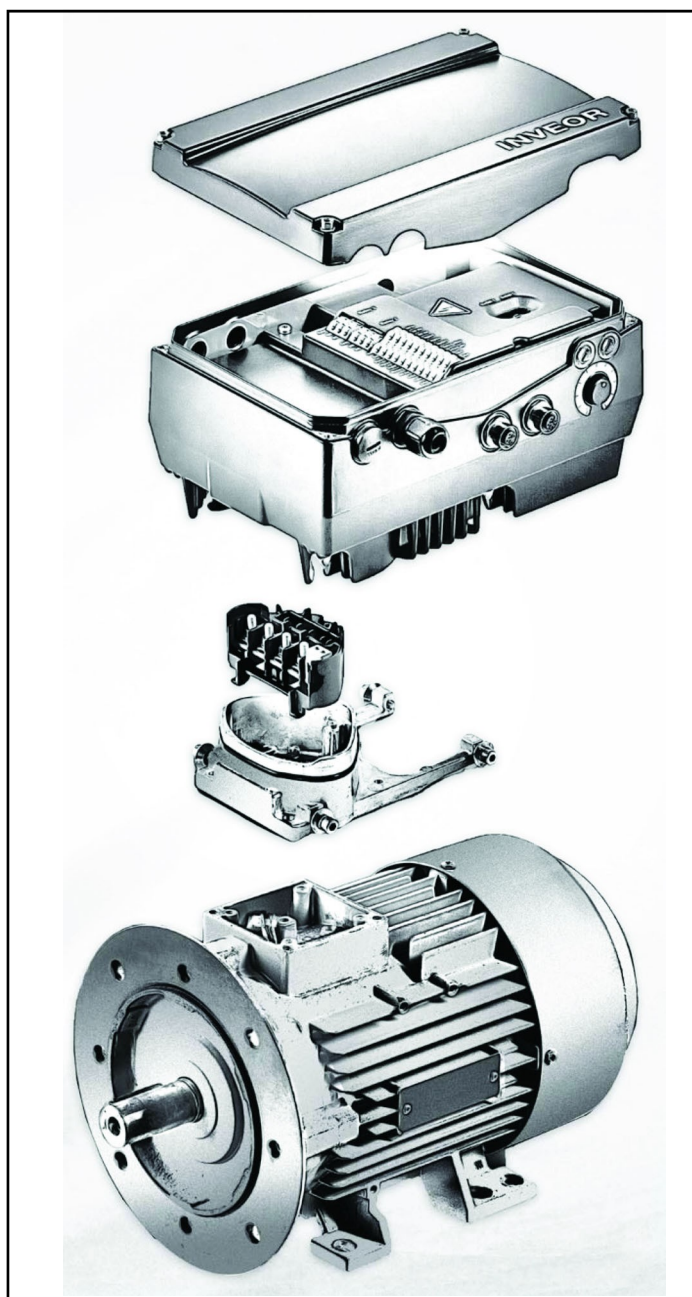

**Service Manual
TECHNICAL
INSTRUCTIONS**

Table of contents:

INVERTER identification, 3

User interface communication (on request), 4

Electrical connections, 5

Motor connection variants for INVERTERS sizes A, B and C, 5

Motor connection variants for INVERTER size D, 6

Connection of INVERTER signals and commands, 7

Electrical connections and parameter configuration, 7

0-10V / 4-20mA analogue input configuration, 8

Configuration of control contact / INVERTER starting and stopping, 9

Configuration of INVERTER start / stop parameters and operating mode, 10

Motor data, 11

Output signal variant for reading motor rpm (optional), 12

Brake chopper connections, 14

Burner terminal with INVERTER interface, 16

IDENTIFICAZIONE INVERTER

INVEOR M_x IV_{xx} PW_{xx} LP_{xx} AP_{xx} GH_{xx} DK_{xx} CO_{xx} 1

1 2 3 4 5 6 7 8 9 10

Key		Key	
1	Drive controller series: INVEOR	6	Application circuit board: AP12 - Standard AP13 - CANopen
2	Installation location/size: motor-integrated - M, size: α, A, B, C, D	7	Control: DK01 - Standard (without membrane keypad) DK04 – With membrane keypad
3	Input voltage : IV02 - 230 V	8	Housing : GH10 – standard heat sink (black painted)
4	Recommended motor rating : kW: 0.55; 0.75; 1.1; 1.5; 2.2; 3.0; 4.0; 5.5; 7.5; 11.0; 15.0; 18.5; 22.0	9	Firmware version : CO00 - Standard CO01 - Specific
5	Printed circuit boards : LP01 / LP03 – Standard (without brake chopper); LP02 / LP04 – Standard (with brake chopper);	10	Equipment generation: 1 – current version

The **LMV5x** device controls fan motor rpm via a sensor and commands it via the inverter with a **4÷20mA** signal.

The **LMV3x/LMV2x** device controls fan motor rpm via a sensor and commands it via the inverter with a **0÷10V** signal.

Generally, the inverter curve goes from 50% to 100% of motor rpm. As well as improving burner regulation, this allows for a saving in terms of fan motor consumption.

INVEOR M INVERTER SIZES

**TAGLIE
INVERTER INVEOR M...**



α



A



B



C



D



User interface

COMMUNICATION (on request)

The drive controller can be put in operation in the following ways:

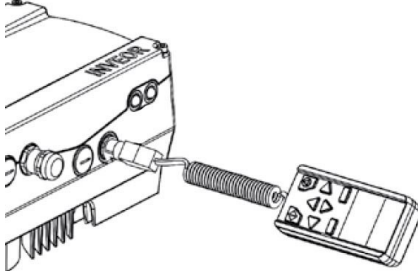

Attention: Contact the manufacturer to order the most suitable device.

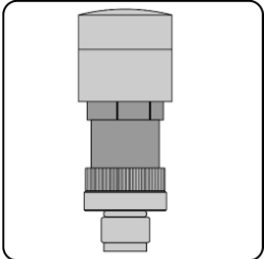
USB adaptor for PC	
Via the INVERTER PC software	
	
INVEOR MMI remote display:	
<p>INVEOR MMI is a portable display on which all inverter parameters can be viewed and changed. Manual available on the KOSTAL website.</p>	
Bluetooth connection:	
<p>Using the Bluetooth adaptor you can connect via app from any device. Download the app for Android / iOS from the Google Play Store / App Store.</p>	
<p>The Bluetooth adaptor is required to create a Bluetooth connection with the inverter. To view and change the inverter parameters, use an external interface device – tablet or mobile phone. Download the app for Android / iOS from the Google Play Store / App Store.</p>	

ELECTRICAL CONNECTIONS

Motor connection variants for INVERTERS sizes A, B and C

Star or delta connection for speed controller integrated on the motor

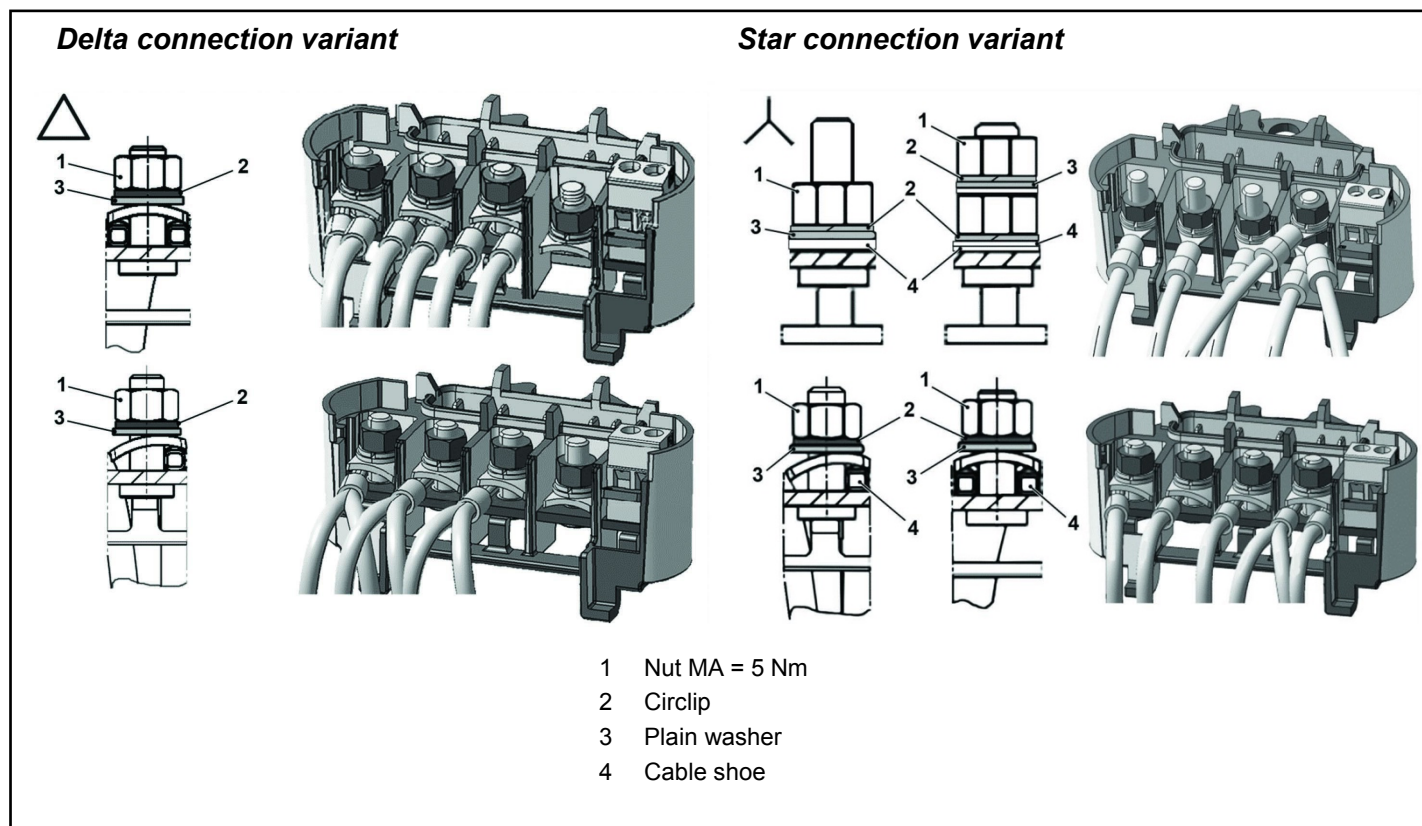
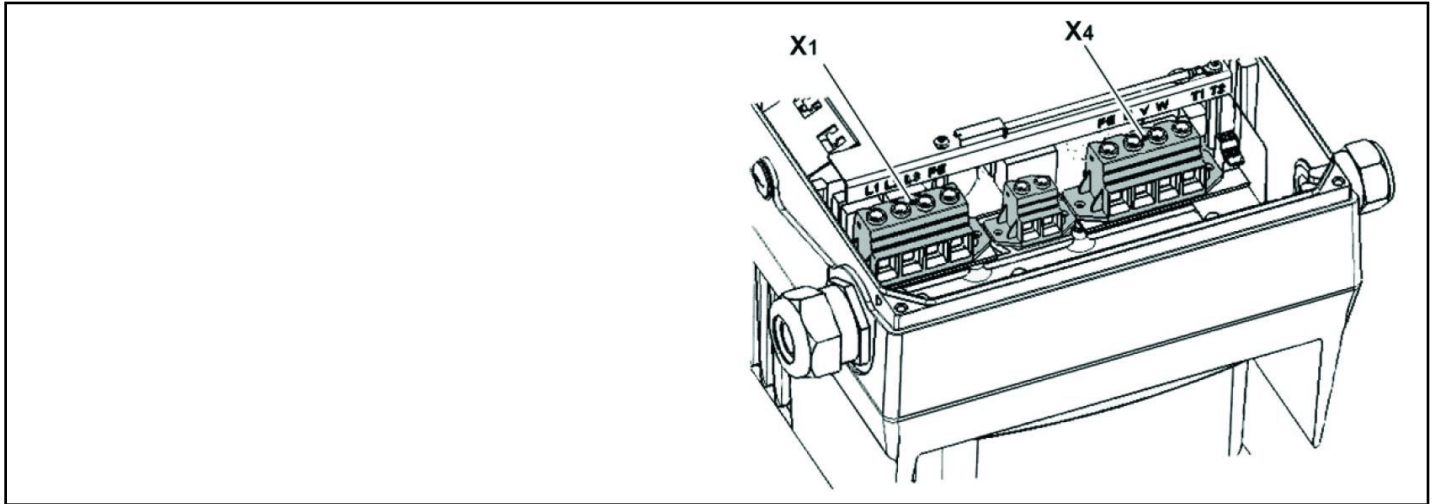

Fig. 1

Motor connection variants for INVERTER size D



X1 terminal no.	Designation	Assignment
1	L1	Mains phase 1
2	L2	Mains phase 2
3	L3	Mains phase 3
4	PE	Protective conductor

Tab. 1 - X1 terminal assignment - 3 x 400 VAC

X4 terminal no.	Designation	Assignment
1	PE	Protective conductor
2	U	Mains phase 1
3	V	Mains phase 2
4	W	Mains phase 3

Tab. 2 - X1 terminal assignment - 3 x 400 VAC

Fig. 2 – Assembly sequence: Connection box – adapter plate size D

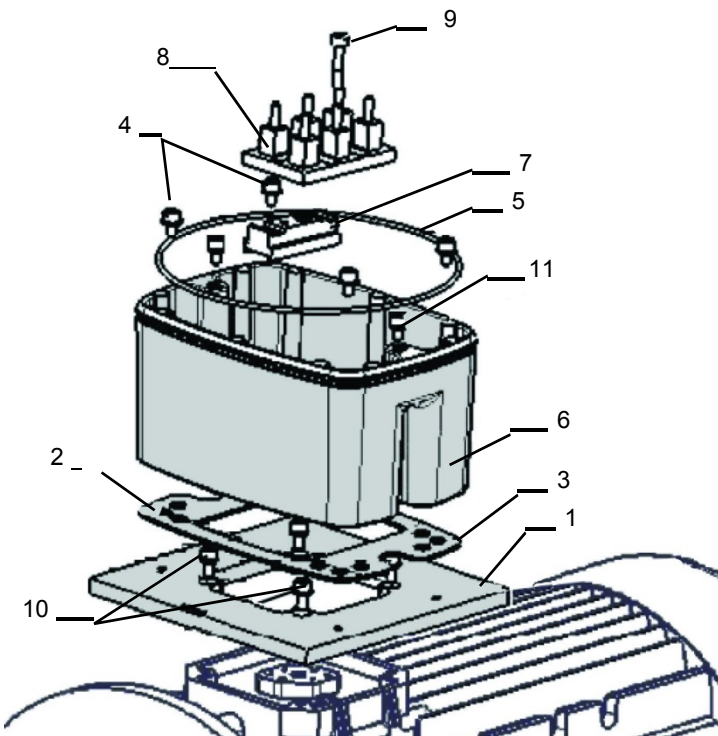

Key:

- 1 Adapter plate option (variant)
- 2 Holes depending on motor
- 3 Seal
- 4 Retaining bolts with spring elements
- 5 O-ring seal
- 6 INVEOR / adapter plate support
- 7 Terminal heightening option
- 8 Original terminal (not included)
- 9 Extended screw option (for pos.7)
- 10 Retaining bolts with spring elements option
- 11 INVEOR/support retaining bolts

Connection of INVERTER signals and commands

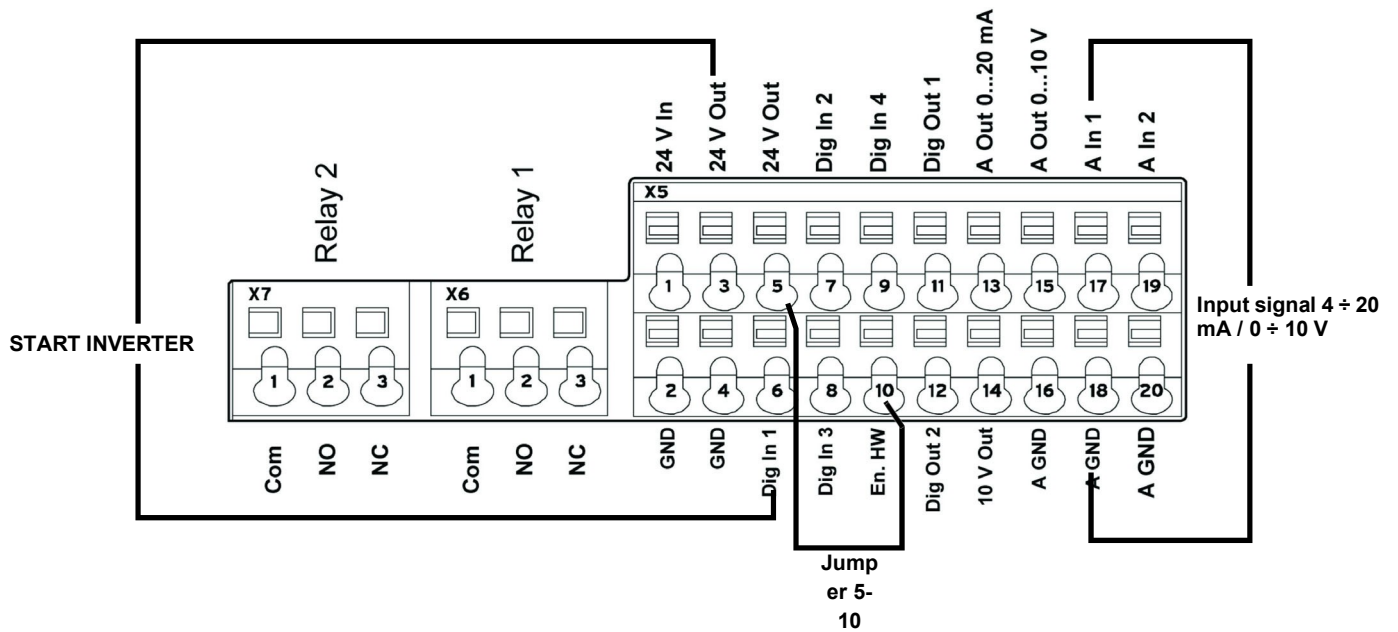

Electrical connections and parameter configuration

There are 2 relays on the INVERTER. Connecting terminals X7-1-2-3 and X6-1-2-3 are used for:

LMV2/3x: Relay 1 is used as a safety contact on the safety loop series of the equipment. Relay 2 is used as a fault indicator on the burner panel front.

LMV5x / ETAMATIC: Relay 1 is used as a contact for control of fan motor start. Relay 2 is used as a fault indicator of the INVERTER to the LMV5x / ETAMATIC equipment.

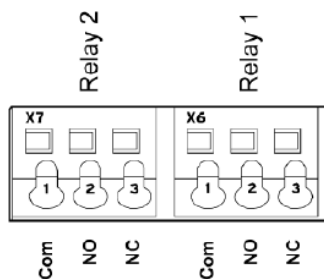

Parameter		
1.181	Automatic reset function	Automatic reset of faults. The INVERTER resets the fault after the set time. Set value = 30 seconds
1.182	Automatic reset numbers	With the reset function the maximum number of automatic resets can be limited. Set value = 0 (maximum number of automatic resets)
4.190	Relay 1 functions	Select the operating mode of relay 1. Set value = LMV2x/3x..= 11 (NC inverted error) Set value = LMV5x / ETAMATIC = 19 (motor is in NO function)
4.210	Relay 2 functions	Select the operating mode of relay 2. Set value = LMV2x/3x..= 11 (NC inverted error) Set value = LMV5x / ETAMATIC = 11 (NC inverted error)
4.210	V O operation	Set value = 10 (NO error)

0-10V / 4-20mA analogue input configuration

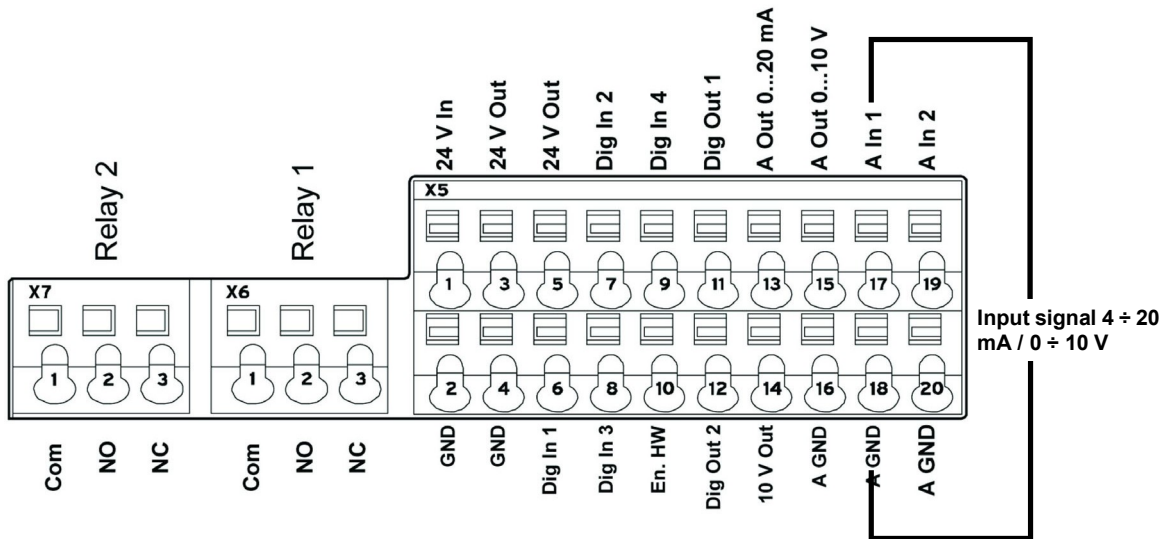

Input AI1 can be configured as voltage or current input. It is configured as 4-20mA input current for LMV5-Etamatic, and 0-10V input voltage for LMV2x/3x.

4.020	Input type AI1	Specifies the input type, whether voltage or current. 1= Voltage input 0-10V (LMV2x/3x) 2= Current input 0/4-20mA (LMV5 ETAMATIC)
4.021	AI1 Standard low	Specifies the minimum value of the analogue input as a percentage of the range. E.g.: 0... 10 V or 0...20 mA = 0 %...100 % 2... 10 V or 4...20 mA = 20 %...100 % Set value = 20% for LMV2x/3x, LMV5x, ETAMATIC
4.022	AI1 Standard high	Specifies the maximum value of the analogue input as a percentage of the range at 10V or 20mA. Set value = 100%
4.023	AI1 Response time	Specifies the deadband on the input signal. Set value = 1%
4.024	AI1 Filter time	An input change is taken into consideration after this time. If it is too short, a wire break error may appear if the 4-20 mA signal goes to 0 for a short time. Set value = 4 seconds
4.030	AI1 Input function	Specifies whether the input is 0 = analogue / 1 = digital input. Set value = 0 analogue
4.033	AI1 Measure unit, input 1	Specifies the unit of measurement of input 1. Set value = 0 (%)
4.034	AI1 Lower limit	Specifies the lower limit of input 1. Set value = 0 (%)
4.035	AI1 Upper limit	Specifies the upper limit of input 1. Set value = 100 (%)
4.036	AI1 Wire break time, 5s	Specifies the time after which the fault appears if input AI1 is interrupted (wire break). Set value = 5 seconds
4.037	AI1 Inversion	Inverts the signal of input 1. Set value = 0 (disabled)

Configuration of control contact / INVERTER starting and stopping

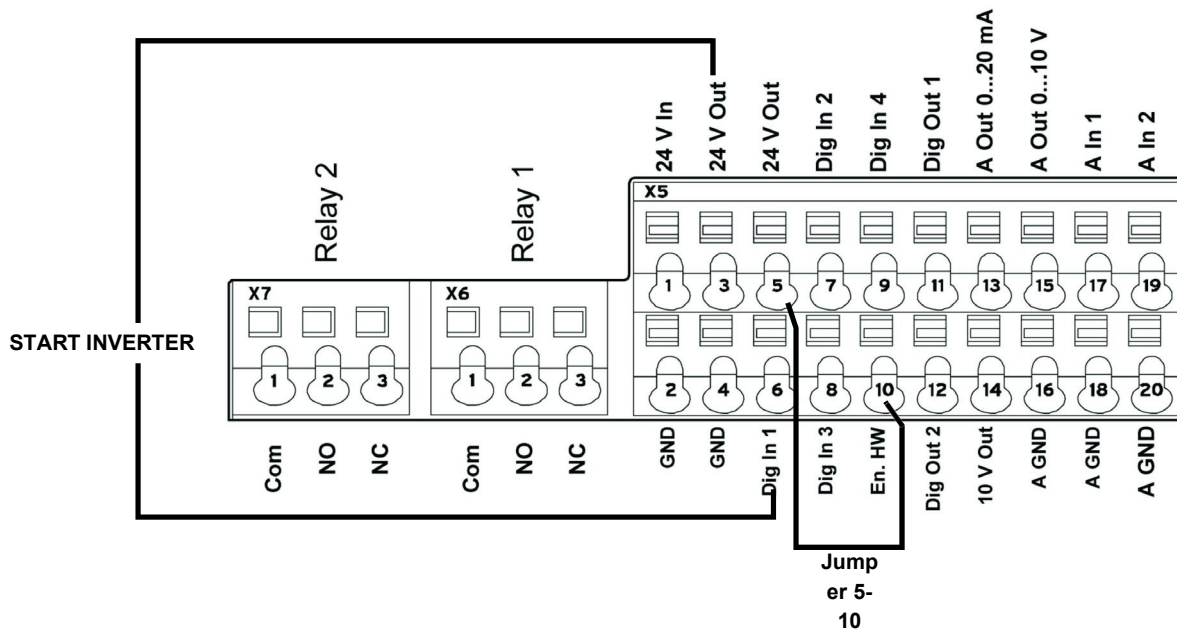

Terminal	
X5-3 (24V Out)... X5-6 (Digit In1)..	Bringing 24V to terminal X5-6 enables INVERTER operation and the contact that switches it on/off. On LMV2/3x X5-3 (24V Out) also powers the motor speed encoder.
X5-5 (24V Out) connected with X5-10 (En.HW)...	Required to enable braking ramp xxxx

Configuration of INVERTER start / stop parameters and operating mode

Parameter		
1.020	Min. frequency (Hz)	Minimum input frequency in Hz. Set value = 0 Hz (LMV2x-3x / LMV5x) Set value = > 35 Hz (ETAMATIC)
1.021	Max. frequency (Hz)	Maximum input frequency in Hz. Set value = 51,5 Hz (LMV2x-3x / LMV5x) Set value = 50 Hz (ETAMATIC)
1.050	Ramp 1 Braking time 1	Braking time at switch-off to reach the speed of 0 Hz after the start/stop contact has opened (not used). Set value = 10 seconds
1.051	Ramp 1 Acceleration time 1	Acceleration time 1 is the time necessary for the drive controller to accelerate from 0 Hz to maximum frequency (not used). Set value = 10 seconds
1.052	Ramp 2 Braking time 2	Braking time at switch-off to reach the speed of 0 Hz after the start/stop contact has opened. Set value = 10 seconds
1.053	Ramp 2 Acceleration time 2	Acceleration time 2 is the time necessary for the drive controller to accelerate from 0 Hz to maximum frequency. Set value = 10 seconds
1.054	Selects ramp used	Digital input 1 (dig In1 / X5-6) selects the ramp used. Set value = 1 (parameters 1.052 and 1.053)
1.088	Quick stop	Not used but set. Set value = 10 seconds
1.100	Operating mode	Frequency control mode: specifies the operating mode of the INVERTER. In our case it is always frequency control (0). Set value = 0
1.130	Reference set point	Determines the source from which the reference value is read. In our case it is always analogue input AI1. Set value = 1 (analogue input 1)
1.131	Enabling software	Depending on the change made, the motor may start immediately. Selection of the source for enabling control. Set value = 0
1.132	Start-up protection	Selection of behaviour in response to enabling software. Set value = 1 (Start only with rising edge at input of control enable)
1.150	Motor rotation direction	Do not change this parameter. To invert the direction of rotation, invert 2 of the 3 INVERTER / MOTOR cabling wires, so that the INVERTERS always have the same setting. Set value = 1 forwards only / clockwise rotation (no changes to direction of rotation are possible)

Motor data

The motor data depend on the type of motor used. Refer to the data shown on the motor nameplate. Follow the steps below:

- Enter the motor data;
- Activate the motor recognition function;
- If the operation ends successfully, enter the remaining parameters.

During the recognition phase, the INVERTER measures some parameters and changes some settings.

N.B.: At each start-up of the recognition programme, recheck all the parameters in this manual.

Parameter		
33.001	Motor type	Selection of motor type. Set value = 1 (asynchronous motor)
33.010	Motor I ² t factor	Not used. Only for encoders. Set value = 100%
33.011	I ² t time	Not used. Only for encoders Set value = 30 seconds
33.015	R optimisation	If necessary, this parameter can be used to optimise the start-up behaviour. Not used Set value = 100%
33.016	Motor phase control	The "Motor connection interrupted" error monitoring (error 45) can be enabled/disabled with this parameter. Set value = 1 (enabled control)
33.031	Motor current	Maximum motor current. Set value = motor nameplate current value in amps
33.032	Motor rating	Motor shaft rating. Set value = motor nameplate rating value in watts
33.034	Motor rpm	Motor rpm. Set value = motor nameplate speed in rpm
33.035	Motor frequency	Nominal motor frequency. Set value = motor nameplate frequency in Hz
33.050	Stator resistance	Recognised by INVERTER. Set value = automatically detected, value in Ohm
33.105	Leakage inductance	Recognised by INVERTER. Set value = automatically detected, value in henry
33.110	Motor voltage	Nominal motor voltage. Set value = 400V
33.111	Motor cos phi	Data on motor nameplate. Set value = 0,xx
33.138	Holding current time	Needed to stop the motor!! After braking it is held at continuous current for a specified time interval. Ensure that there is no overheating in this phase. Recommended time: max 5 s. Set value = 0 seconds

Activate the “Motor identification” function and follow the instructions proposed by the INVERTER, then change the parameters described below. The image shows the software screen on the PC.

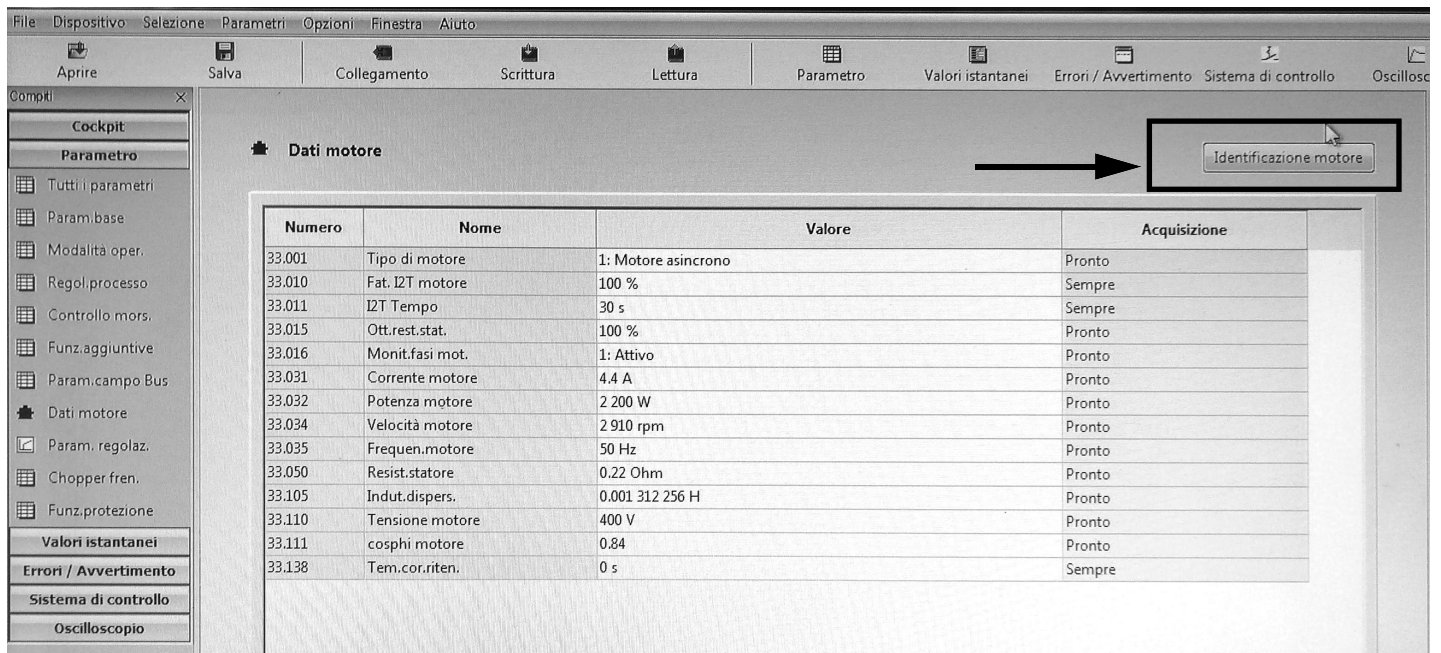

Parameter		
34.010	Control type	Open-loop asynchronous motor. Set value = 100 (open-loop asynchronous motor)
34.020	Flying restart	Set value = 1 (enabled)
34.021	Flying restart time	Calculated by Inverter. Set value = value calculated by INVERTER in ms
34.090	Speed controller Kp	Calculated by the inverter during the motor recognition phase. Reset it to 2000 after motor recognition. Set value = 2000 mA/rad/sec
34.091	Speed controller Tn	Calculated by the inverter during the motor recognition phase. Reset it to 7.5 seconds after motor recognition. Set value = 7.5 seconds
34.110	Slip trimmer	If set to 1 the function is enabled. If set to 0 the motor performs as if connected to the mains. If compensation is enabled, the system aligns the stator frequency with the rotor. As a result, the actual motor rpm increase and are brought in line with the theoretical motor nameplate rpm. The motor is supplied with the same voltage and frequency, but the current increases and the rpm are brought to the nameplate data. Set value = 1 (compensation for slippage)

Output signal variant for reading motor rpm (optional)

To have a 4-20 mA analogue output that indicates the motor rpm to the terminals X5-13 (Aout 0-20 mA) and X5-16 (A GND), set the parameters below:

Parameter		
4.100	Analogue output AO1	Selection of analogue output options. In our case, to have an output proportional to the rpm, set 19. Set value = 19 (actual rpm)
4.101	Minimum value of analogue output AO1	Output signal at 0-20 mA. To obtain a 4-20 mA signal with (4 mA = 0 motor rpm), follow the example: if motor rpm are a maximum 2900, calculate: $2900 / 20 \times 4 = 580$, which is the negative value corresponding to 0 mA from which to start. Therefore: 0 mA = - 580, 20 mA = 2900 Set value = - xxx (-580 in the example)
4.102	Maximum value of analogue output AO1	Maximum rpm value for 20 mA. Set value = xxxx (2900 in the above example)

NOTE 1	If the system enters pendulum mode with LMV.. / ETAMATIC, adjust parameters 34.090 and 34.091 by increasing them, in particular parameter 34.090 , in steps of 100mA/rad/sec.
NOTE 2	With LMV 2x/3x with INVERTER control, the device controls the standby rpm with param. 653 . If, after the fan is switched off, the device LMV 2x/3x sees that the motor continues to run, error 83 diagnostic 32 appears. This occurs if there is significant fan inertia (e.g. on burners with very heavy forward curved blades), then always disable parameter 653, setting it to 0 .
NOTE 3	With LMV 2x/3x the signal 0-10V for motor rpm control during standardisation is brought to approximately 9.7 V and the fan motor rpm is saved. According to the LMV manual, the INVERTER should be set to max 52.5 Hz During standardisation, the INVERTER is driven at approximately 51 ÷ 51.5 Hz and may go out of absorption range with the motor. For this reason, set the INVERTER to max 51.5 Hz. During standardisation, the INVERTER will reach 50Hz and the over-absorption problem will be reduced.
NOTE 4	If the <u>analogue wire break fault</u> is displayed on the INVERTER and the 4-20 mA inverter signal continues to oscillate between 1 ÷ 6 mA, it does not always mean that the LMV 2x/3x or ETAMATIC equipment is faulty. It could be due to the old firmware of the INVERTER and should therefore be updated. If this is the case, contact the Service Centre.

FAULTS / PROBLEMS.. SOLUTIONS		
Parameter 36.020	If error 36 appears	Problems detected in the mains supply. By setting this parameter to 0, the INVERTER no longer checks the mains and the error message disappears. It is recommended to leave the parameter set to 1.
Parameter 33.105	If mains voltage drops during operation	When the mains voltage drops, the INVERTER decreases the motor rpm. To reduce this change, set the parameter to 0, which should solve the problem.

Brake chopper connections

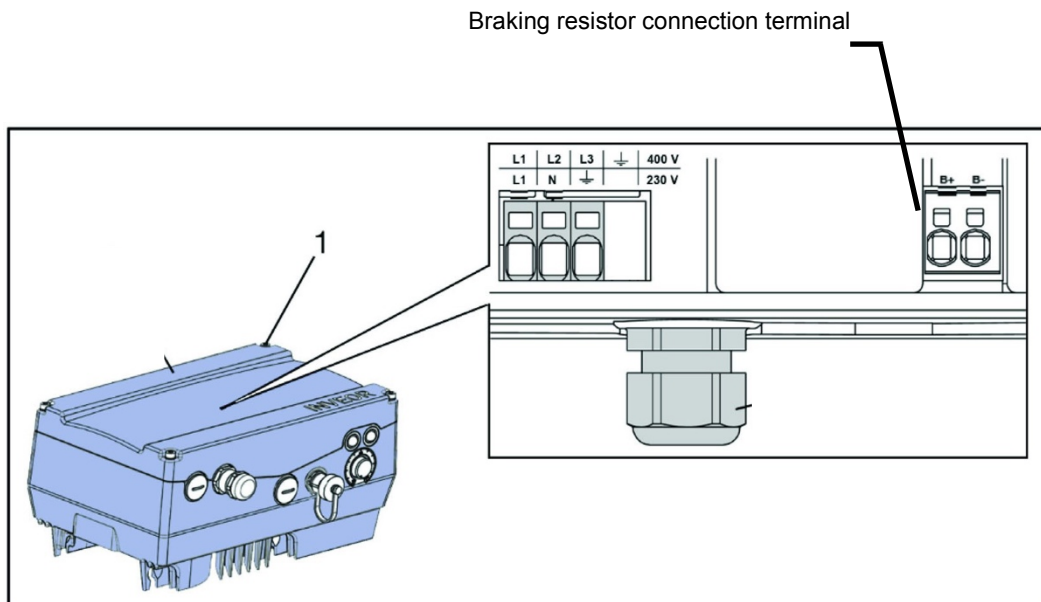

Brake chopper connections

Terminal no.	Designation	Assignment
1	B+	Braking resistor connection (+)
2	B-	Braking resistor connection (-)

Optional assignment of brake chopper

Parameter	
Braking resistor	Enabled or disabled

Braking resistors

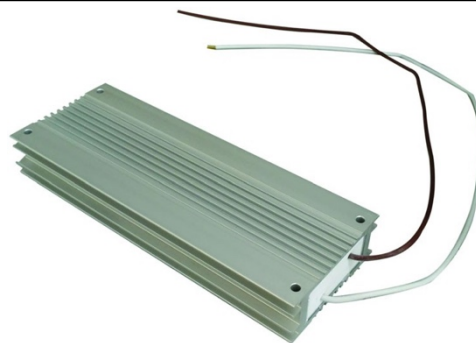

Burner terminal block with interface INVERTER

Versioni bruciatore con LMV2x/3x

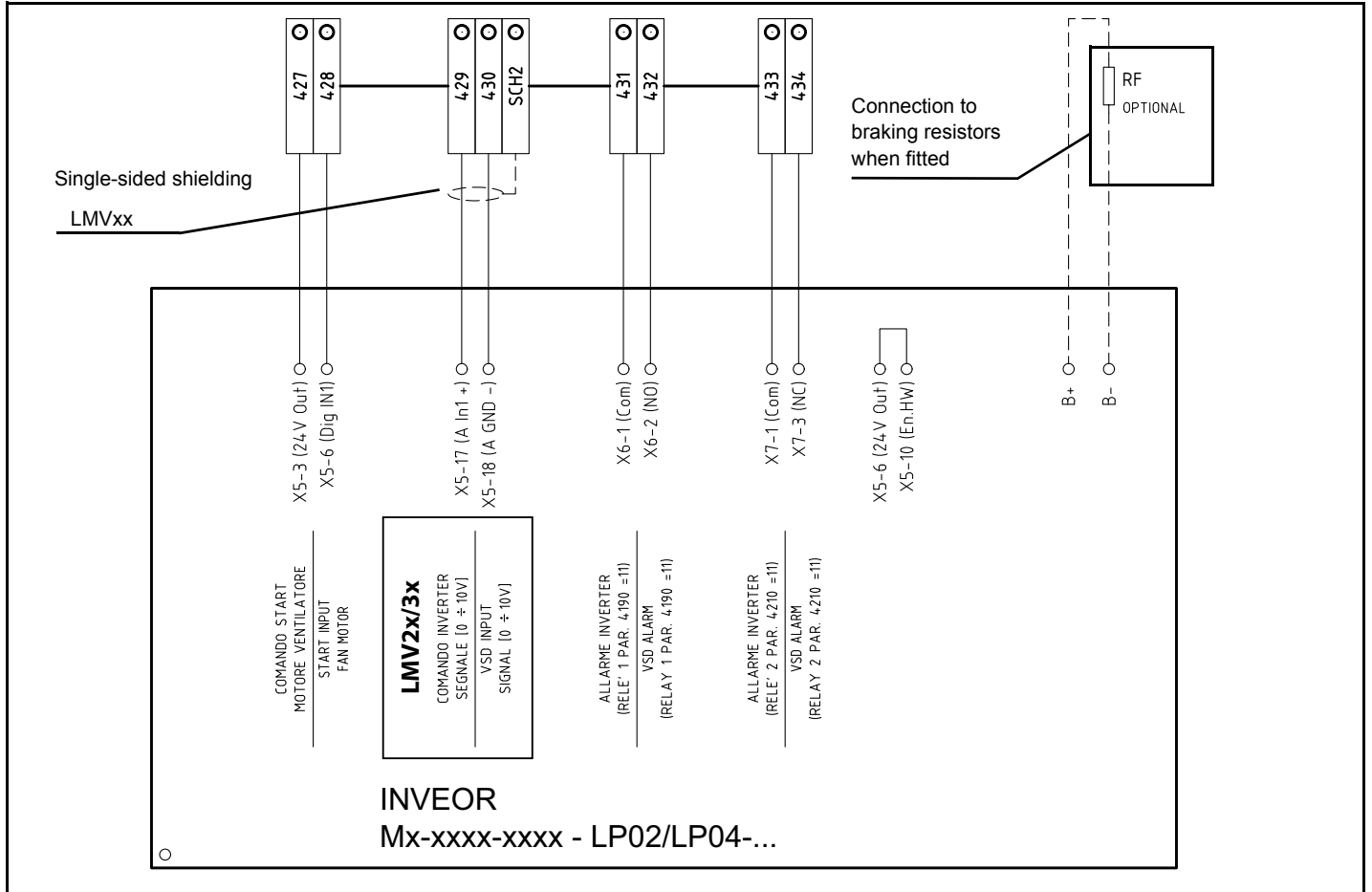

Versioni bruciatore con LMV5x o ETAMATIC

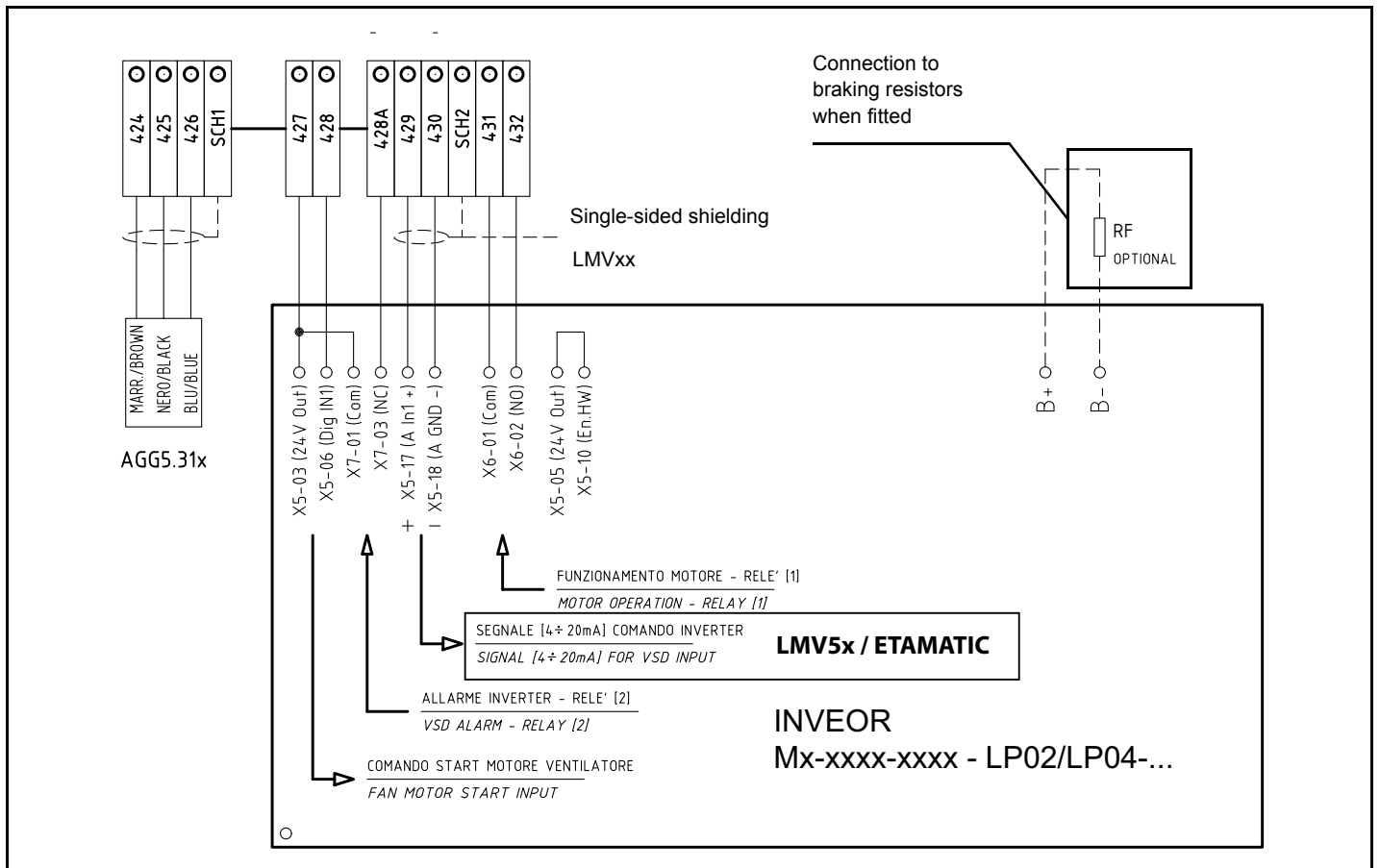



C.I.B. UNIGAS S.p.A.
Via L.Galvani, 9 - 35011 Campodarsego (PD) - ITALY
Tel. +39 049 9200944 - Fax +39 049 9200945/9201269
web site: www.cibunigas.it - e-mail: cibunigas@cibunigas.it

Note: specifications and data subject to change. Errors and omissions excepted.