

PG60

PG70

PG81

Light oil burners
Progressive / Fully-modulating

MANUAL OF INSTALLATION - USE - MAINTENANCE

CIB UNIGAS

BURNERS - BRUCIATORI - BRULERS - BRENNER - QUEMADORES - ГОРЕЛКИ

DANGERS, WARNINGS AND NOTES OF CAUTION

THIS MANUAL IS SUPPLIED AS AN INTEGRAL AND ESSENTIAL PART OF THE PRODUCT AND MUST BE DELIVERED TO THE USER.

INFORMATION INCLUDED IN THIS SECTION ARE DEDICATED BOTH TO THE USER AND TO PERSONNEL FOLLOWING PRODUCT INSTALLATION AND MAINTENANCE.

THE USER WILL FIND FURTHER INFORMATION ABOUT OPERATING AND USE RESTRICTIONS, IN THE SECOND SECTION OF THIS MANUAL. WE HIGHLY RECOMMEND TO READ IT.

CAREFULLY KEEP THIS MANUAL FOR FUTURE REFERENCE.

1) GENERAL INTRODUCTION

- The equipment must be installed in compliance with the regulations in force, following the manufacturer's instructions, by qualified personnel.
- Qualified personnel means those having technical knowledge in the field of components for civil or industrial heating systems, sanitary hot water generation and particularly service centres authorised by the manufacturer.
- Improper installation may cause injury to people and animals, or damage to property, for which the manufacturer cannot be held liable.
- Remove all packaging material and inspect the equipment for integrity. In case of any doubt, do not use the unit - contact the supplier.

The packaging materials (wooden crate, nails, fastening devices, plastic bags, foamed polystyrene, etc), should not be left within the reach of children, as they may prove harmful.

- Before any cleaning or servicing operation, disconnect the unit from the mains by turning the master switch OFF, and/or through the cut-out devices that are provided.
- Make sure that inlet or exhaust grilles are unobstructed.
- In case of breakdown and/or defective unit operation, disconnect the unit. Make no attempt to repair the unit or take any direct action.

Contact qualified personnel only.

Units shall be repaired exclusively by a servicing centre, duly authorised by the manufacturer, with original spare parts and accessories.

Failure to comply with the above instructions is likely to impair the unit's safety.

To ensure equipment efficiency and proper operation, it is essential that maintenance operations are performed by qualified personnel at regular intervals, following the manufacturer's instructions.

- When a decision is made to discontinue the use of the equipment, those parts likely to constitute sources of danger shall be made harmless.
- In case the equipment is to be sold or transferred to another user, or in case the original user should move and leave the unit behind, make sure that these instructions accompany the equipment at all times so that they can be consulted by the new owner and/or the installer.
- This unit shall be employed exclusively for the use for which it is meant. Any other use shall be considered as improper and, therefore, dangerous.

The manufacturer shall not be held liable, by agreement or otherwise, for damages resulting from improper installation, use and failure to comply with the instructions supplied by the manufacturer. The occurrence of any of the following circumstances may cause explosions, polluting unburnt gases (example: carbon monoxide CO), burns, serious harm to people, animals and things:

- Failure to comply with one of the WARNINGS in this chapter
- Incorrect handling, installation, adjustment or maintenance of the burner
- Incorrect use of the burner or incorrect use of its parts or optional supply

2) SPECIAL INSTRUCTIONS FOR BURNERS

- The burner should be installed in a suitable room, with ventilation openings complying with the requirements of the regulations in force, and sufficient for good combustion.
- Only burners designed according to the regulations in force should be used.
- This burner should be employed exclusively for the use for which it was designed.
- Before connecting the burner, make sure that the unit rating is the same as delivery mains (electricity, gas oil, or other fuel).
- Observe caution with hot burner components. These are, usually, near to the flame and the fuel pre-heating system, they become hot during the unit operation and will remain hot for some time after the burner has stopped.

When the decision is made to discontinue the use of the burner, the user shall have qualified personnel carry out the following operations:

- a Remove the power supply by disconnecting the power cord from the mains.
- b Disconnect the fuel supply by means of the hand-operated shut-off valve and remove the control handwheels from their spindles.

Special warnings

- Make sure that the burner has, on installation, been firmly secured to the appliance, so that the flame is generated inside the appliance fire-box.
- Before the burner is started and, thereafter, at least once a year, have qualified personnel perform the following operations:
 - a set the burner fuel flow rate depending on the heat input of the appliance;
 - b set the flow rate of the combustion-supporting air to obtain a combustion efficiency level at least equal to the lower level required by the regulations in force;
 - c check the unit operation for proper combustion, to avoid any harmful or polluting unburnt gases in excess of the limits permitted by the regulations in force;
 - d make sure that control and safety devices are operating properly;
 - e make sure that exhaust ducts intended to discharge the products of combustion are operating properly;
 - f on completion of setting and adjustment operations, make sure that all mechanical locking devices of controls have been duly tightened;
 - g make sure that a copy of the burner use and maintenance instructions is available in the boiler room.
- In case of a burner shut-down, reset the control box by means of the RESET pushbutton. If a second shut-down takes place, call the Technical Service, **without trying to RESET further**.
- The unit shall be operated and serviced by qualified personnel only, in compliance with the regulations in force.

3) GENERAL INSTRUCTIONS DEPENDING ON FUEL USED

3a) ELECTRICAL CONNECTION

- For safety reasons the unit must be efficiently earthed and installed as required by current safety regulations.
- It is vital that all safety requirements are met. In case of any doubt, ask for an accurate inspection of electrics by qualified personnel, since the manufacturer cannot be held liable for damages that may be caused by failure to correctly earth the equipment.
- Qualified personnel must inspect the system to make sure that it is adequate to take the maximum power used by the equipment shown on the equipment rating plate. In particular, make sure that the system cable cross section is adequate for the power absorbed by the unit.
- No adaptors, multiple outlet sockets and/or extension cables are permitted to connect the unit to the electric mains.
- An omnipolar switch shall be provided for connection to mains, as required by the current safety regulations.
- The use of any power-operated component implies observance of a few basic rules, for example:
 - do not touch the unit with wet or damp parts of the body and/or with bare feet;
 - do not pull electric cables;
 - do not leave the equipment exposed to weather (rain, sun, etc.) unless expressly required to do so;
 - do not allow children or inexperienced persons to use equipment;
- The unit input cable shall not be replaced by the user. In case of damage to the cable, switch off the unit and contact qualified personnel to replace. When the unit is out of use for some time the electric switch supplying all the power-driven components in the system (i.e. pumps, burner, etc.) should be switched off.

3b) FIRING WITH GAS, LIGHT OIL OR OTHER FUELS

GENERAL

- The burner shall be installed by qualified personnel and in compliance with regulations and provisions in force; wrong installation can cause injuries to people and animals, or damage to property, for which the manufacturer cannot be held liable.
- Before installation, it is recommended that all the fuel supply system pipes be carefully cleaned inside, to remove foreign matter that might impair the burner operation.
- Before the burner is commissioned, qualified personnel should inspect the following:
 - a the fuel supply system, for proper sealing;
 - b the fuel flow rate, to make sure that it has been set based on the firing rate required of the burner;
 - c the burner firing system, to make sure that it is supplied for the designed fuel type;
 - d the fuel supply pressure, to make sure that it is included in the range shown on the rating plate;
 - e the fuel supply system, to make sure that the system dimensions are adequate to the burner firing rate, and that the system is equipped with all the safety and control devices required by the regulations in force.
- When the burner is to remain idle for some time, the fuel supply tap or taps should be closed.

SPECIAL INSTRUCTIONS FOR USING GAS

Have qualified personnel inspect the installation to ensure that:

- a the gas delivery line and train are in compliance with the regulations and provisions in force;
 - b all gas connections are tight;
 - c the boiler room ventilation openings are such that they ensure the air supply flow required by the current regulations, and in any case are sufficient for proper combustion.
- Do not use gas pipes to earth electrical equipment.
 - Never leave the burner connected when not in use. Always shut the gas valve off.
 - In case of prolonged absence of the user, the main gas delivery valve to the burner should be shut off.

Precautions if you can smell gas

- a do not operate electric switches, the telephone, or any other item likely to generate sparks;
 - b immediately open doors and windows to create an air flow to purge the room;
 - c close the gas valves;
 - d contact qualified personnel.
- Do not obstruct the ventilation openings of the room where gas appliances are installed, to avoid dangerous conditions such as the development of toxic or explosive mixtures.

DIRECTIVES AND STANDARDS

Gas burners

European directives

- Regulation 2016/426/UE (appliances burning gaseous fuels)
- 2014/35/UE (Low Tension Directive)
- 2014/30/UE (Electromagnetic compatibility Directive)
- 2006/42/EC (Machinery Directive)

Harmonized standards

- UNI EN 676 (Automatic forced draught burners for gaseous fuels)
- EN 55014-1 (Electromagnetic compatibility- Requirements for household appliances, electric tools and similar apparatus)
- EN 60204-1:2006 (Safety of machinery – Electrical equipment of machines.)
- CEI EN 60335-1 (Specification for safety of household and similar electrical appliances);
- CEI EN 60335-2-102 (Household and similar electrical appliances. Safety. Particular requirements for gas, oil and solid-fuel burning appliances having electrical connections).
- UNI EN ISO 12100:2010 (Safety of machinery - General principles for design - Risk assessment and risk reduction);

Light oil burners

European directives

- 2014/35/UE (Low Tension Directive)
- 2014/30/UE (Electromagnetic compatibility Directive)
- 2006/42/EC (Machinery Directive)

Harmonized standards

- UNI EN 267-2011(Automatic forced draught burners for liquid fuels)
- EN 55014-1 (Electromagnetic compatibility- Requirements for household appliances, electric tools and similar apparatus)
- EN 60204-1:2006 (Safety of machinery – Electrical equipment of machines.)
- CEI EN 60335-1 (Specification for safety of household and similar electrical appliances);
- CEI EN 60335-2-102 (Household and similar electrical appliances. Safety. Particular requirements for gas, oil and solid-fuel burning appliances having electrical connections).
- UNI EN ISO 12100:2010 (Safety of machinery - General principles for design - Risk assessment and risk reduction);

Heavy oil burners

European Directives

- 2014/35/UE (Low Tension Directive)
- 2014/30/UE (Electromagnetic compatibility Directive)
- 2006/42/EC (Machinery Directive)

Harmonized standards

- UNI EN 267(Automatic forced draught burners for liquid fuels)
- EN 55014-1 (Electromagnetic compatibility- Requirements for household appliances, electric tools and similar apparatus)
- EN 60204-1:2006 (Safety of machinery – Electrical equipment of machines.)
- CEI EN 60335-1 (Specification for safety of household and similar electrical appliances);
- CEI EN 60335-2-102 (Household and similar electrical appliances. Safety. Particular requirements for gas, oil and solid-fuel burning appliances having electrical connections).
- UNI EN ISO 12100:2010 (Safety of machinery - General principles for design - Risk assessment and risk reduction);

Gas - Light oil burners

European Directives

- Regulation 2016/426/UE (appliances burning gaseous fuels)
- 2014/35/UE (Low Tension Directive)
- 2014/30/UE (Electromagnetic compatibility Directive)
- 2006/42/EC (Machinery Directive)

Harmonized standards

- UNI EN 676 (Automatic forced draught burners for gaseous fuels)
- UNI EN 267 (Automatic forced draught burners for liquid fuels)
- EN 55014-1 (Electromagnetic compatibility- Requirements for household appliances, electric tools and similar apparatus)
- EN 60204-1:2006 (Safety of machinery – Electrical equipment of machines.)
- CEI EN 60335-1 (Specification for safety of household and similar electrical appliances);
- CEI EN 60335-2-102 (Household and similar electrical appliances. Safety. Particular requirements for gas, oil and solid-fuel burning appliances having electrical connections).
- UNI EN ISO 12100:2010 (Safety of machinery - General principles for design - Risk assessment and risk reduction);

Gas - Heavy oil burners

European directives:

- Regulation 2016/426/UE (appliances burning gaseous fuels)
- 2014/35/UE (Low Tension Directive)
- 2014/30/UE (Electromagnetic compatibility Directive)
- 2006/42/EC (Machinery Directive)

Harmonized standards

- UNI EN 676 (Automatic forced draught burners for gaseous fuels)
- EN 55014-1 (Electromagnetic compatibility- Requirements for household appliances, electric tools and similar apparatus)
- EN 60204-1:2006 (Safety of machinery – Electrical equipment of machines.)
- CEI EN 60335-1 (Specification for safety of household and similar electrical appliances);
- CEI EN 60335-2-102 (Household and similar electrical appliances. Safety. Particular requirements for gas, oil and solid-fuel burning appliances having electrical connections).
- UNI EN ISO 12100:2010 (Safety of machinery - General principles for design - Risk assessment and risk reduction);

Industrial burners

European directives

- Regulation 2016/426/UE (appliances burning gaseous fuels)
- 2014/35/UE (Low Tension Directive)
- 2014/30/UE (Electromagnetic compatibility Directive)
- 2006/42/EC (Machinery Directive)

Harmonized standards

- EN 55014-1 (Electromagnetic compatibility- Requirements for household appliances, electric tools and similar apparatus)
- EN 746-2 (Industrial thermoprocessing equipment - Part 2: Safety requirements for combustion and fuel handling systems)
- UNI EN ISO 12100:2010 (Safety of machinery - General principles for design - Risk assessment and risk reduction);
- EN 60204-1:2006 (Safety of machinery – Electrical equipment of machines.)
- EN 60335-2 (Electrical equipment of non-electric appliances for household and similar purposes. Safety requirements)

Burner data plate

For the following information, please refer to the data plate:

- burner type and burner model: must be reported in any communication with the supplier
- burner ID (serial number): must be reported in any communication with the supplier
- date of production (year and month)
- information about fuel type and network pressure

| | |
|--------------|----|
| Type | -- |
| Model | -- |
| Year | -- |
| S.Number | -- |
| Output | -- |
| Oil Flow | -- |
| Fuel | -- |
| Category | -- |
| Gas Pressure | -- |
| Viscosity | -- |
| El.Supply | -- |
| El.Consump. | -- |
| Fan Motor | -- |
| Protection | -- |
| Drwaing n° | -- |
| P.I.N. | -- |

SYMBOLS USED



WARNING!

Failure to observe the warning may result in irreparable damage to the unit or damage to the environment



DANGER!

Failure to observe the warning may result in serious injuries or death.



WARNING!

Failure to observe the warning may result in electric shock with lethal consequences

Figures, illustrations and images used in this manual may differ in appearance from the actual product.

BURNER SAFETY

The burners - and the configurations described below - comply with the regulations in force regarding health, safety and the environment. For more in-depth information, refer to the declarations of conformity that are an integral part of this Manual.



DANGER! Incorrect motor rotation can seriously damage property and injure people.

Residual risks deriving from misuse and prohibitions

The burner has been built in order to make its operation safe; there are, however, residual risks.



Do not touch any mechanical moving parts with your hands or any other part of your body. Injury hazard
Do not touch any parts containing fuel (i.e. tank and pipes). Scalding hazard
Do not use the burner in situations other than the ones provided for in the data plate.
Do not use fuels other than the ones stated.
Do not use the burner in potentially explosive environments.
Do not remove or by-pass any machine safety devices.
Do not remove any protection devices or open the burner or any other component while the burner is running.
Do not disconnect any part of the burner or its components while the burner is running.
Untrained staff must not modify any linkages.



After any maintenance, it is important to restore the protection devices before restarting the machine.
All safety devices must be kept in perfect working order.
Personnel authorized to maintain the machine must always be provided with suitable protections.



ATTENTION: while running, the parts of the burner near the generator (coupling flange) are subject to overheating. Where necessary, avoid any contact risks by wearing suitable PPE.

PART I: INSTALLATION

GENERAL FEATURES

Monobloc burners of this series are made in die-cast aluminium housing with relative flange to work on heating generators. The output range is from 150kW to 1900kW (according to the model). They can be provided in progressive or fully-modulating version.

The fuel coming from the supply line, is pushed by the pump to the nozzle and then into the combustion chamber, where the mixture between fuel and air takes place and consequently the flame.

In the burners, the mixture between fuel and air, to perform clean and efficient combustion, is activated by atomisation of oil into very small particles. This process is achieved making pressurised oil pass through the nozzle.

The pump main function is to transfer oil from the tank to the nozzle at required quantity and pressure. To adjust pressure, pumps are provided with a pressure governor (except some models for which a separate adjusting valve is provided). Other pumps are provided with two pressure governors: one for high and one for low pressure (in double-stage systems with one nozzle).

In the double-stage burners, the electric actuator, that moves the air damper, allows the optimisation of the gas flue values, as to get an efficient combustion. The position of the combustion head determines the burner output. The air (comburent) and fuel (light oil) are forced into the combustion chamber, as to let the flame light up.

How to interpret the burner's "Performance curve"

To check if the burner is suitable for the boiler to which it must be installed, the following parameters are needed:

- furnace input, in kW or kcal/h ($\text{kW} = \text{kcal/h} / 860$);
- backpressure (data are available on the boiler ID plate or in the user's manual).

Example:

Furnace input: 600kW

Backpressure: 4mbar

In the "Performance curve" diagram (Fig. 1), draw a vertical line matching the furnace input value and an horizontal line matching the backpressure value. The burner is suitable if the intersection point A is inside the performance curve.

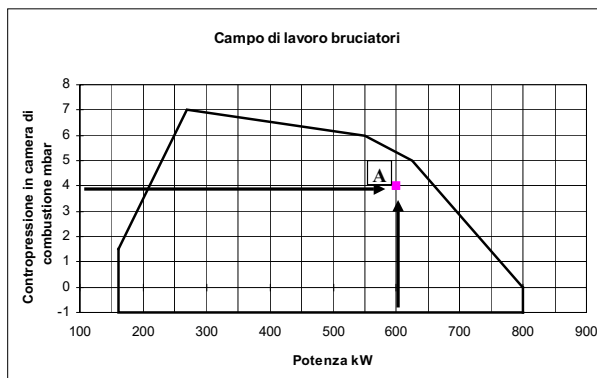

Fig. 1

Data are referred to standard conditions: atmospheric pressure at 1013mbar, ambient temperature at 15°C

Burner model identification

Burners are identified by burner type and model. Burner model identification is described as follows.

| Type PG60 | Model | G- | PR. | S. | * | A. |
|-----------------------------------|---|-----------|------------|-----------|----------|-----------|
| (1) | (2) | (3) | (4) | (5) | (6) | (6) |
| (1) BURNER TYPE | PG60-PG70-PG81 | | | | | |
| (2) FUEL | G - Light oil A - Biodiesel K - Kerosene | | | | | |
| (3) OPERATION(Available versions) | PR - Progressive MD - Fully modulating | | | | | |
| (4) BLAST TUBE | S - Standard L - Extended | | | | | |
| (5) DESTINATION COUNTRY | * - see data plate* | | | | | |
| (6) BURNER VERSION | A - Standard Y - Speciale | | | | | |

Technical specifications

| BURNERS | | PG60 | PG70 | PG81 |
|-----------------------|-------------------|--------------------------------|-------------|-------------|
| Output | min. -max. kW | 151 - 791 | 291 - 1047 | 264-1900 |
| Fuel | | Light oil | | |
| Light oil rate | min. -max. kg/h | 13 - 67 | 25 - 88 | 22-160 |
| Kerosene rate | min. -max. kg/h | 12,6 - 66 | 24 - 87 | 22-159 |
| Light Oil viscosity | cSt @ 40°C | 2 - 7,4 | | |
| Light Oil density | kg/m ³ | 840 | | |
| Power supply | | 400V 3N ~ 50Hz | | |
| Approx. weight | kg | 55 | 85 | 85 |
| Operation | | Progressive - Fully modulating | | |
| Operating temperature | °C | -10 ÷ +50 | | |
| Storage Temperature | °C | -20 ÷ +60 | | |
| Working service(*) | | Intermittent | | |

Electrical data 50 Hz

Possible voltages, check the actual three-phase and single-phase supply voltage on the burner data plate.

| | | | | |
|-------------------------------------|----|---------------------------------------|-----|------|
| Power supply Triphase | V | 230 / 400 3 a.c. | | |
| Auxiliary power supply Mono Phase | V | 115 2 a.c. / 220 2 a.c. / 230 1N a.c. | | |
| | Hz | 50 | | |
| Fan motor | kW | 1,1 | 2,2 | 3,0 |
| Separated pump motor (*if supplied) | kW | - | - | 0,55 |
| Total power consumption | kW | 1,6 | 2,7 | 4,05 |

Electrical data 60 Hz

Possible voltages, check the actual three-phase and single-phase supply voltage on the burner data plate.

| | | | | |
|-------------------------------------|----|--|------|------|
| Power supply Triphase | V | 220 / 230 / 265 / 277 / 380 / 400 / 440 / 460 / 480 / 525 3 a.c. | | |
| Auxiliary power supply Mono Phase | V | 110 / 120 / 220 / 230 2 a.c. / 230 1N a.c. | | |
| | Hz | 60 | | |
| Fan motor | kW | 1,32 | 2,64 | 3,6 |
| Separated pump motor (*if supplied) | kW | - | - | 0,66 |
| Total power consumption | kW | 1,82 | 3,14 | 4,76 |



WARNING: Burners are suitable only for indoor operation with a maximum relative humidity of 80%

(*)NOTE ON THE BURNER WORKING SERVICE:

- Burners provided with Siemens LOA24 control box: for safety reasons, one controlled shutdown must take place every 24 hours.
- Burners provided with Siemens LMO24-44 control box: the control box automatically stops after 24h of continuous working. The control box immediately starts up, automatically.

(**) The distance between the measurement surface and the burner body is 1 meter (UNI EN ISO 3744)

Performance curves

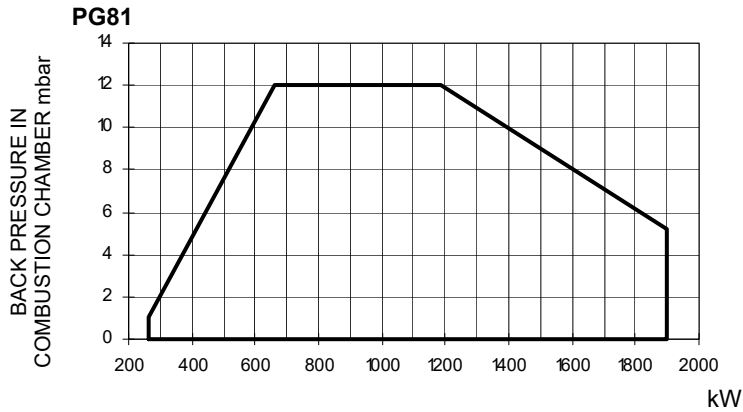
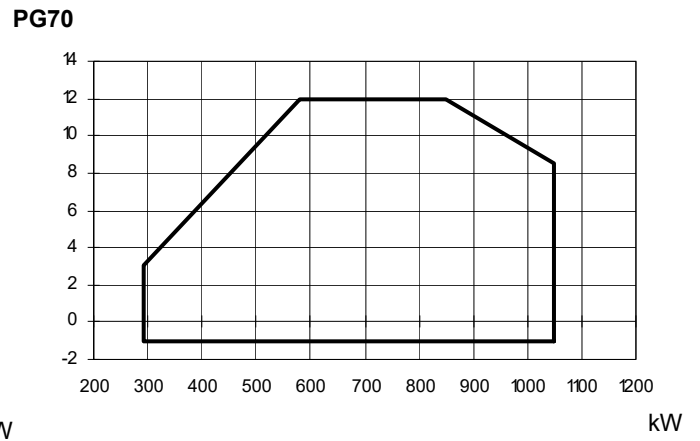
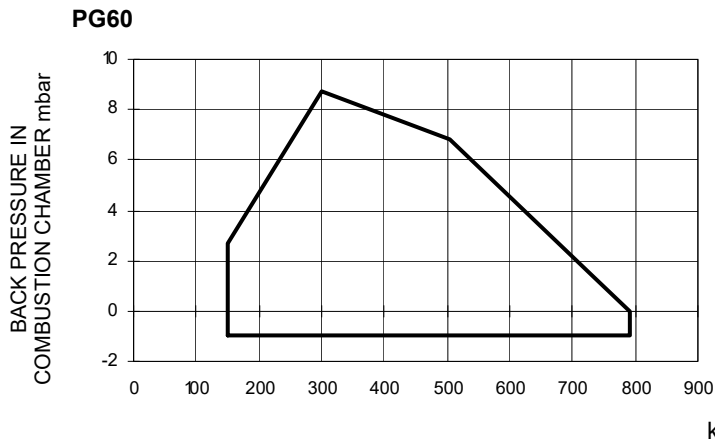

To get the input in kcal/h, multiply value in kW by 860.

Data are referred to standard conditions: atmospheric pressure at 1013mbar, ambient temperature at 15°C.

NOTE: The performance curve is a diagram that represents the burner performance in the type approval phase or in the laboratory tests, but does not represent the regulation range of the machine. On this diagram the maximum output point is usually reached by adjusting the combustion head to its "MAX" position (see paragraph "Adjusting the combustion head"); the minimum output point is reached setting the combustion head to its "MIN" position. During the first ignition, the combustion head is set in order to find a compromise between the burner output and the generator specifications, that is why the minimum output may be different from the Performance curve minimum.

Overall dimensions (mm)

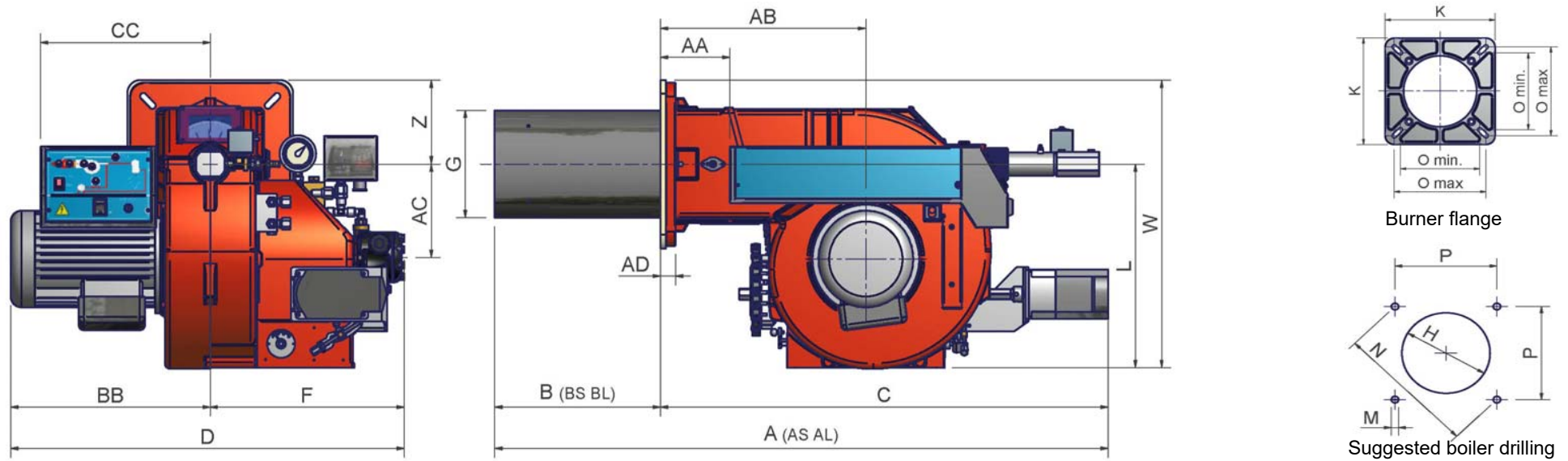

8

| | AS | AL | AA | BS | BL | BB | C | CC | D | F | G | K | H | L | Omin | Omax | P | M | N | P | W | Z |
|-------------|------|------|-----|-----|-----|-----|-----|-----|-----|-----|-----|-----|-----|-----|------|------|-----|-----|-----|-----|-----|-----|
| PG60 | 1014 | 1212 | 99 | 244 | 442 | 314 | 770 | 362 | 729 | 415 | 153 | 240 | 182 | 344 | 190 | 190 | 190 | M10 | 269 | 190 | 464 | 120 |
| PG70 | 1147 | 1297 | 130 | 310 | 460 | 373 | 837 | 317 | 736 | 363 | 198 | 300 | 228 | 374 | 216 | 250 | 233 | M10 | 330 | 233 | 529 | 155 |
| PG81 | 1177 | 1327 | 139 | 340 | 490 | 373 | 837 | 382 | 736 | 363 | 234 | 300 | 264 | 376 | 216 | 250 | 233 | M10 | 330 | 233 | 531 | 155 |

*B, C = measure referred to burner fitted with standard blast tube

*BL, CL = measure referred to burner fitted with extended blast tube

(PG60, PG70, PG81) HYDRAULIC DIAGRAMS

Fig. 3 - 3I2G-24 v0 Hydraulic diagram

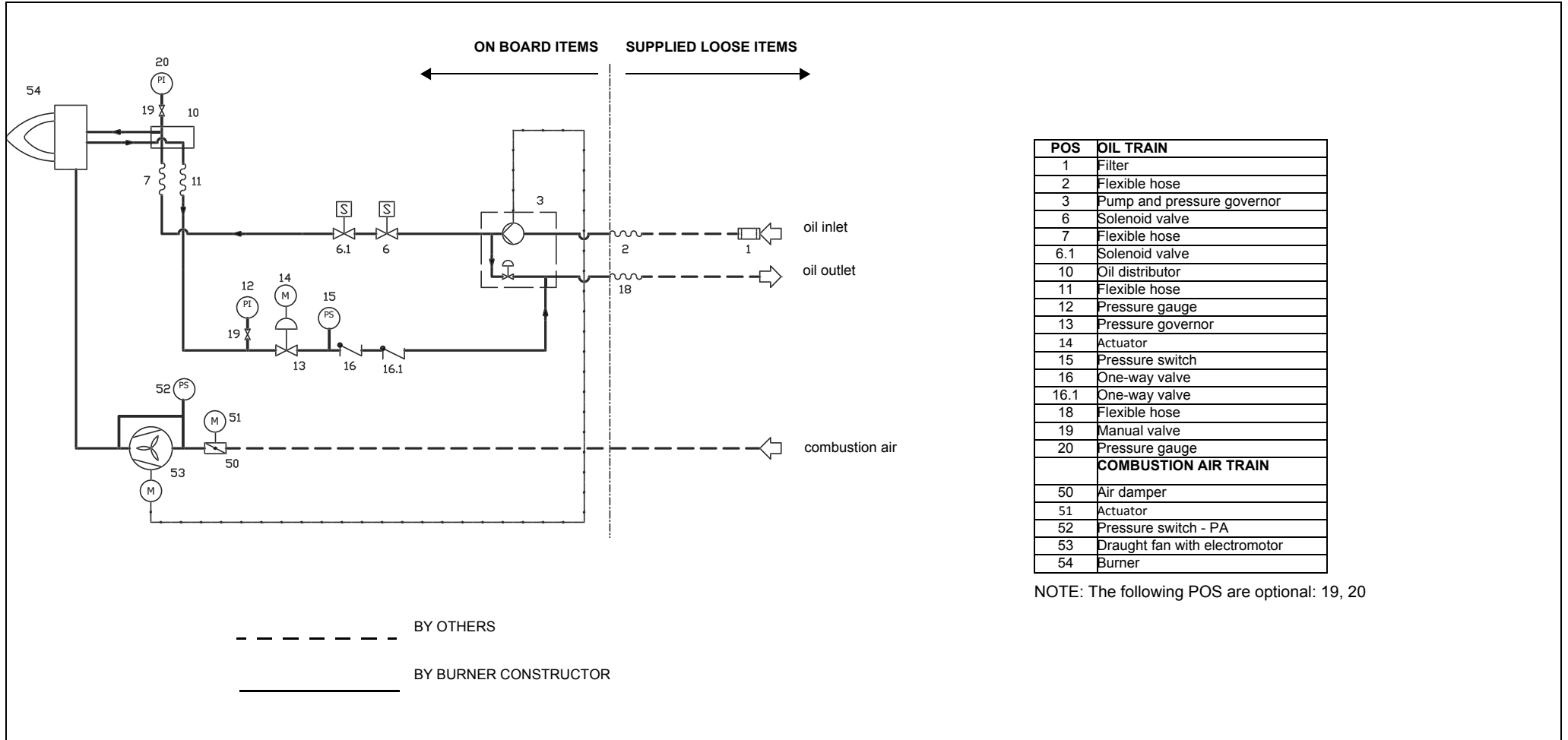
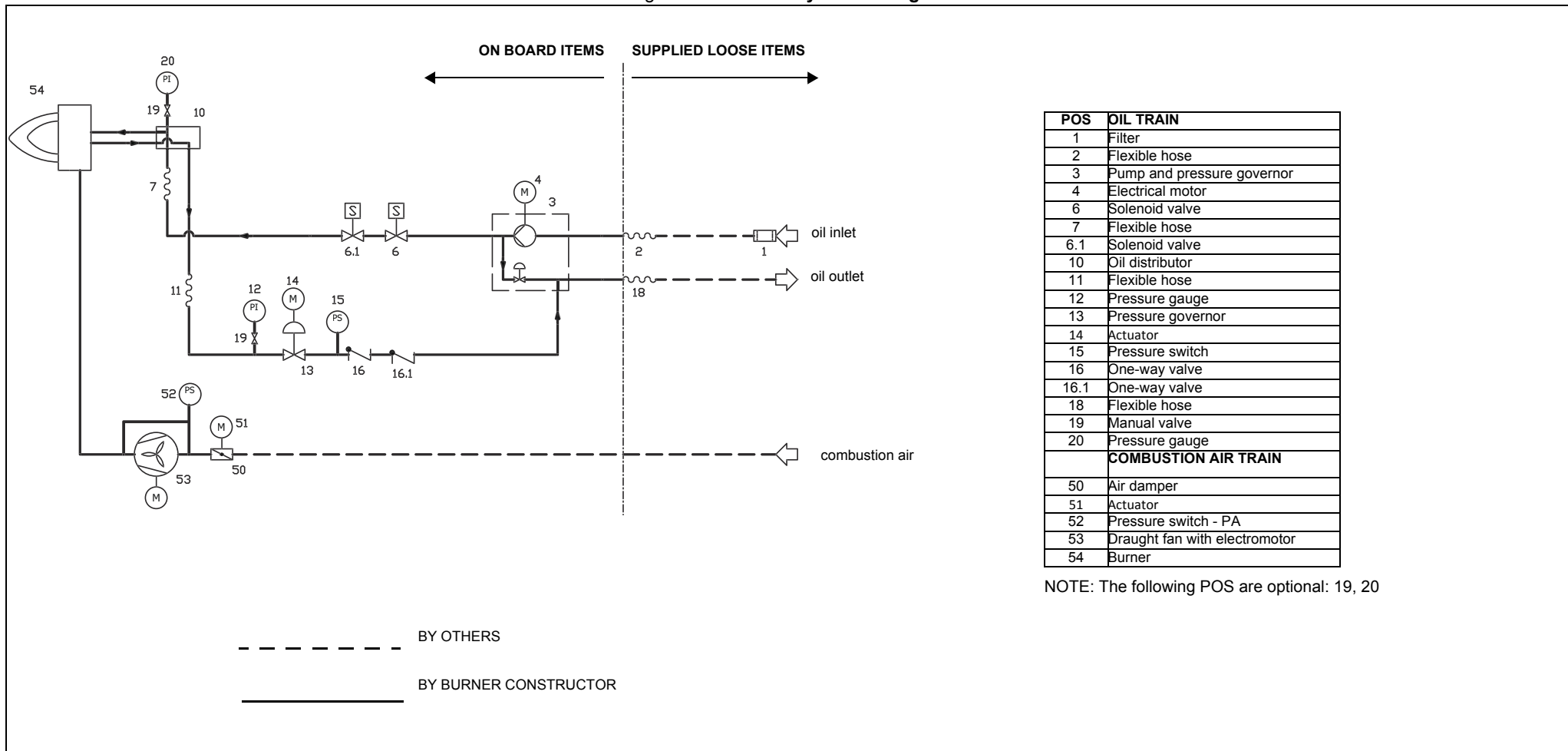

Fig. 4 - 3I2G-23 v0 Hydraulic diagram



NOTE: The following POS are optional: 19, 20

Fig. 5

MOUNTINGS AND CONNECTIONS

Transport and storage



ATTENTION! The equipment must be installed in compliance with the regulations in force, following the manufacturer's instructions, by qualified personnel. All handling operations must be carried out with appropriate resources and qualified personnel



ATTENTION: Use intact and correctly dimensioned hoisting equipment, conforms to the local regulations and health and safety regulations. Do not stand under lifted loads.

If the product must be stored, avoid humid and corrosive places. Observe the temperatures stated in the burner data table at the beginning of this manual.

Packing

The burners are dispatched in wooden packages whose dimensions are:

PG60: 1200 x 670 x 540 mm (L x P x H)

PG70-PG81: 1400 x 1000 x 220 mm (L x P x H)

Packing cases of this kind are affected by humidity and are not suitable for stacking. The following are placed in each packing case.

- 1 burner;
- 2 light oil flexible hoses;
- 1 light oil filter;
- 1 gasket to be inserted between the burner and the boiler;
- 1 envelope containing this manual.

To get rid of the burner's packing, follow the procedures laid down by current laws on disposal of materials.

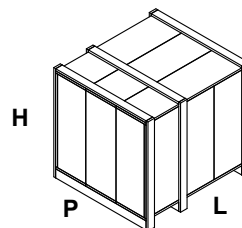

Fitting the burner to the boiler

To install the burner into the boiler, proceed as follows:

- 1 make a hole on the closing door of the combustion chamber as described on paragraph "Overall dimensions")
- 2 place the burner to the boiler: lift it up and handle it according to the procedure described on paragraph "Handling the burner";
- 3 place the stud bolts (5) on boiler's door, according to the burner drilling template described on paragraph "Overall dimensions";
- 4 fasten the stud bolts;
- 5 place the gasket on the burner flange;
- 6 install the burner into the boiler;
- 7 fix the burner to the stud bolts, by means of the fixing nuts, according to the next picture.
- 8 After fitting the burner to the boiler, ensure that the gap between the blast tube and the refractory lining is sealed with appropriate insulating material (ceramic fibre cord or refractory cement).

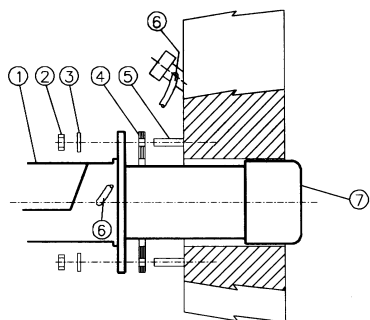

Keys

- 1 Burner
- 2 Fixing nut
- 3 Washer
- 4 Sealing gasket
- 5 Stud bolt
- 7 Blast tube

Handling the burner



ATTENTION! The handling operations must be carried out by specialised and trained personnel. If these operations are not carried out correctly, the residual risk for the burner to overturn and fall down still persists.

To move the burner, use means suitable to support its weight (see paragraph "Technical specifications").

Matching the burner to the boiler

The burners described in this manual have been tested with combustion chambers that comply with EN676 regulation and whose dimensions are described in the diagram. In case the burner must be coupled with boilers with a combustion chamber smaller in diameter or shorter than those described in the diagram, please contact the supplier, to verify that a correct matching is possible, with respect of the application involved. To correctly match the burner to the boiler verify the type of the blast tube. Verify the necessary input and the pressure in combustion chamber are included in the burner performance curve; otherwise the choice of the burner must be revised consulting the burner manufacturer. To choose the blast tube length follow the instructions of the boiler manufacturer. In absence of these consider the following:

- Cast-iron boilers, three pass flue boilers (with the first pass in the rear part): the blast tube must protrude no more than **Dist** = 100 mm into the combustion chamber. (please see the picture below)
- Pressurised boilers with flame reversal: in this case the blast tube must penetrate **Dm** 50 ÷ 100 mm into combustion chamber in respect to the tube bundle plate.(please see the picture below)

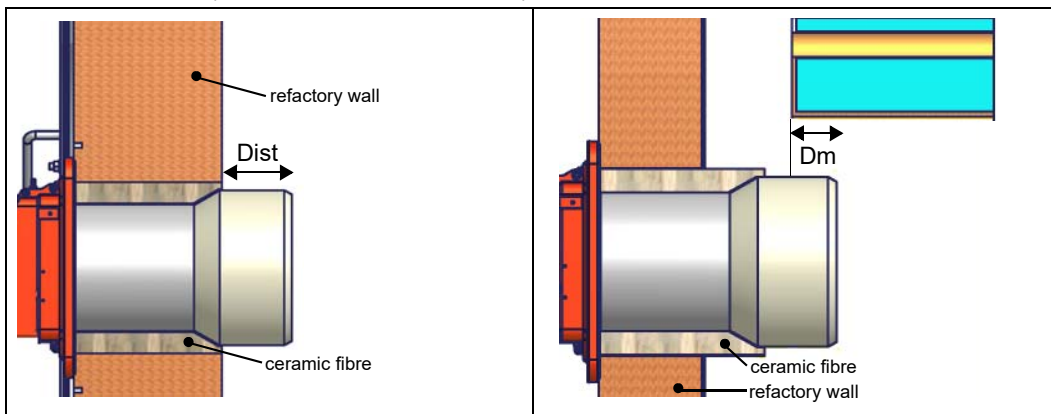

ATTENTION! Carefully seal the free space between blast tube and the refractory lining with ceramic fibre rope or other suitable means.

The length of the blast tubes does not always allow this requirement to be met, and thus it may be necessary to use a suitably-sized spacer to move the burner backwards or to design a blast tube that suits the utilisation (please, contact the manufacturer).

Hydraulic diagrams for light oil supplying circuits

Fig. 2 - Gravity circuit

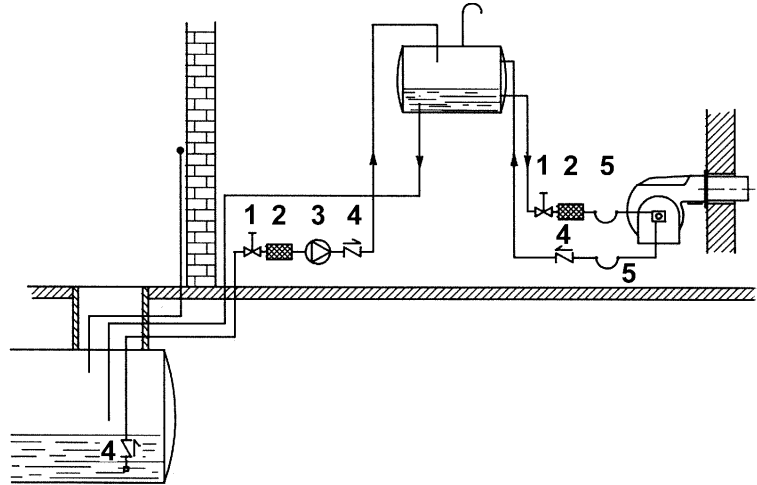

Fig. 3 - Ring circuit

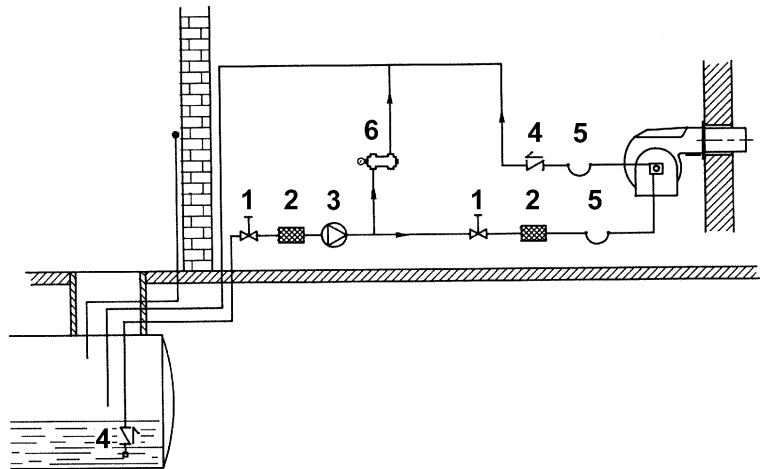
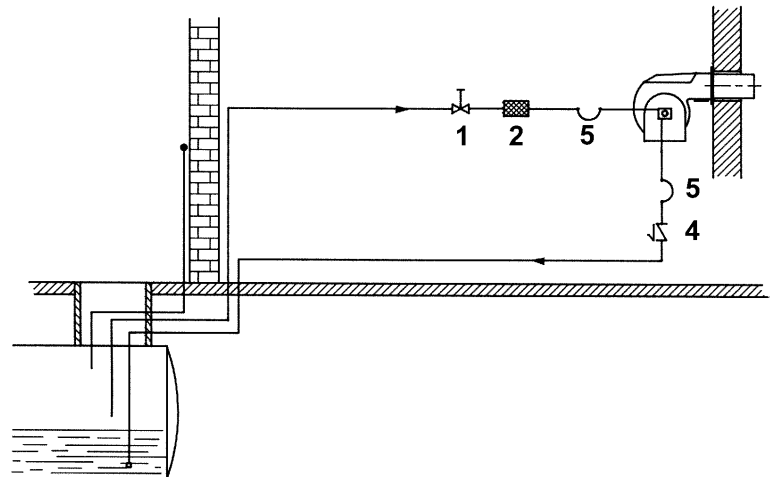

Fig. 4 - Suction circuit



Key

- 1 Manual valve
- 2 Light oil filter
- 3 Light oil feeding pump
- 4 One way valve
- 5 Flexible hoses
- 6 Relief valve

NOTE: in plants where gravity or ring feed systems are provided, install an automatic interception device (see n. 4 - Fig. 5).

Installation diagram of light oil pipes

⚠ PLEASE READ CAREFULLY THE “WARNINGS” CHAPTER AT THE BEGINNING OF THIS MANUAL.

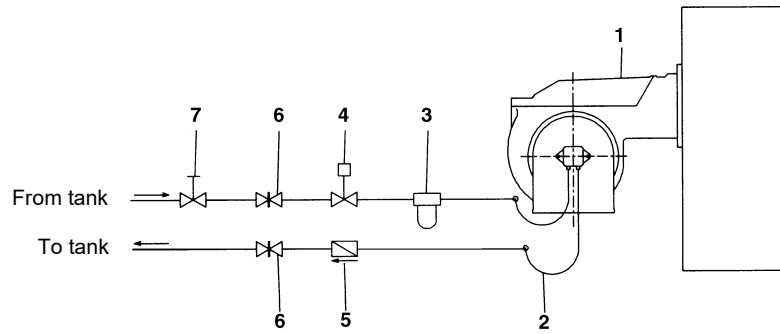

Fig. 5 - Double-pipe system

The burner is supplied with filter and flexible hoses, all the parts upstream the filter and downstream the return flexible hose, must be installed by the customer. As far as the hoses connection, see the related paragraph.

Key

- 1 Burner
- 2 Flexible hoses (fitted)
- 3 Light oil filter (fitted)
- 4 Automatic interceptor (*)
- 5 One-way valve (*)
- 6 Gate valve
- 7 Quick-closing gate-valve (outside the tank or boiler rooms)

(*) Only for installations with gravity, siphon or forced circulation feed systems. If the device installed is a solenoid valve, a timer must be installed to delay the valve closing.

The direct connection of the device without a timer may cause pump breaks.

The provided pumps can be installed both into single-pipe and double-pipe systems.

Single-pipe system: a single pipe drives the oil from the tank to the pump's inlet. Then, from the pump, the pressurised oil is driven to the nozzle: a part comes out from the nozzle while the other part goes back to the pump. In this system, the by-pass plug, if provided, must be removed and the optional return port, on the pump's body, must be sealed by steel plug and washer.

Double-pipe system: as for the single pipe system, a pipe that connects the tank to the pump's inlet is used besides another pipe that connects the pump's return port to the tank, as well. The excess of oil goes back to the tank: this installation can be considered self-bleeding. If provided, the inside by-pass plug must be installed to avoid air and fuel passing through the pump.

Burners are factory-set for double-stage systems. They can be suited for single-pipe system (recommended in the case of gravity feed) as described before. To change from a 1-pipe system to a 2-pipe-system, insert the by-pass plug **G** (as for ccw-rotation- referring to the pump shaft).

Caution: Changing the direction of rotation, all connections on top and side are reversed.

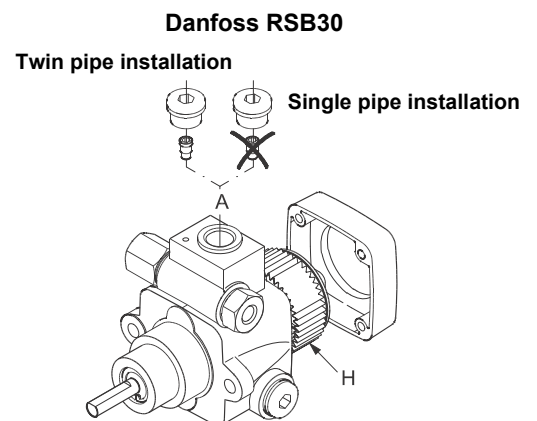
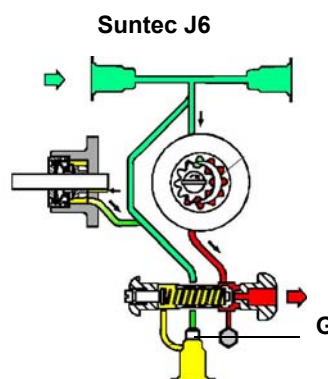
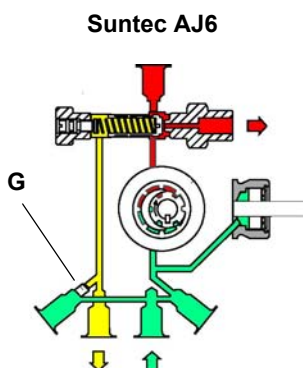

Suntec TA

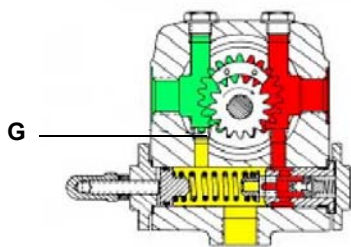

Danfoss KSM..L

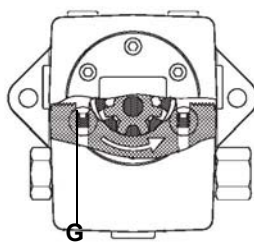

About the use of fuel pumps

- Do not use fuel with additives to avoid the possible formation over time of compounds which may deposit between the gear teeth, thus obstructing them.
- After filling the tank, wait before starting the burner. This will give any suspended impurities time to deposit on the bottom of the tank, thus avoiding the possibility that they might be sucked into the pump.
- On initial commissioning a "dry" operation is foreseen for a considerable length of time (for example, when there is a long suction line to bleed). To avoid damages inject some lubrication oil into the vacuum inlet.
- Care must be taken when installing the pump not to force the pump shaft along its axis or laterally to avoid excessive wear on the joint, noise and overloading the gears.
- Pipes should not contain air pockets. Rapid attachment joint should therefore be avoided and threaded or mechanical seal junctions preferred. Junction threads, elbow joints and couplings should be sealed with removable seal component. The number of junctions should be kept to a minimum as they are a possible source of leakage.
- Do not use PTFE tape on the suction and return line pipes to avoid the possibility that particles enter circulation. These could deposit on the pump filter or the nozzle, reducing efficiency. Always use O-Rings or mechanical seal (copper or aluminium gaskets) junctions if possible.
- An external filter should always be installed in the suction line upstream the fuel unit.



ATTENTION: before the burner first start, it is mandatory to fill the adduction pipes with diesel fuel and bleed out residual air bubbles. Prior to switching on the burner, check direction of rotation of the pump motor by briefly pressing the starter switch; ensure there are no anomalous sounds during equipment operation, and only then turn on the burner. Neglect to comply with this requirement will invalidate the burner warranty.

Light oil pumps

The pumps provided with these burners can be:

- PG60: Suntec AJ6
- PG70: Suntec J6/Danfoss RSB30
- PG81: Suntec TA2 / Danfoss KSM50 / HP- UHE-A

| Pump Suntec AJ6 | |
|------------------------|----------------------------|
| Viscosity | 2.8 - 75 cSt |
| Oil temperature | 60°C max |
| Inlet maximum pressure | 2 bar |
| Inlet minimum pressure | - 0.45 bar to avoid gasing |
| Rated speed | 3600 rpm max. |

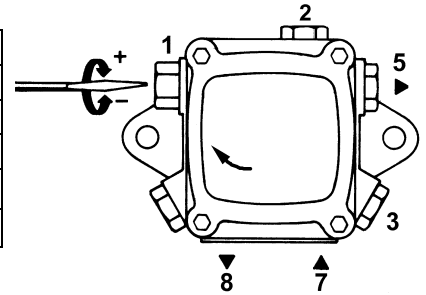

| Suntec J6 - J7 | |
|-----------------------|----------------------------|
| Oil viscosity | 2.8 - 200 cSt |
| Oil temperature | 0 - 90°C |
| Min. suction pressure | - 0,45 bar to avoid gasing |
| Max. suction pressure | 1.5 bar |
| Max. return pressure | 1.5 bar |
| Rotation speed | 3600 rpm max. |

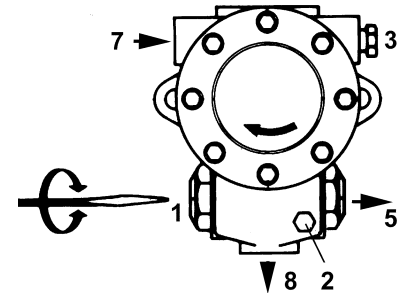

Key

- 1 Pressure governor
- 2 Pressure gauge
- 3 Vacuum gauge
- 5 Nozzle
- 7 Suction
- 8 Return

Danfoss RSB

| | |
|-------------------------|------------------------|
| Oil viscosity | 2,5 ÷ 200 cSt |
| Oil temperature | -10 ÷ 120°C |
| Inlet maximum pressure | 4 bar |
| Maximum return pressure | 4 bar |
| Minimum inlet pressure | - 0,45 to avoid gasing |
| Rotation speed max. | 3600 rpm |

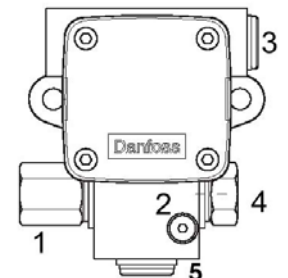

Key

- 1 Pressure governor
- 2 Pressure gauge
- 3 Suction
- 4 To nozzle
- 5 Return

| Suntec TA.. | |
|-----------------------|----------------------------|
| Oil viscosity | 3 ÷ 75 cSt |
| Oil temperature | 0 ÷ 150°C |
| Min. suction pressure | - 0.45 bar to avoid gasing |
| Max. suction pressure | 5 bar |
| Max. return pressure | 5 bar |
| Rotation speed | 3600 rpm max. |

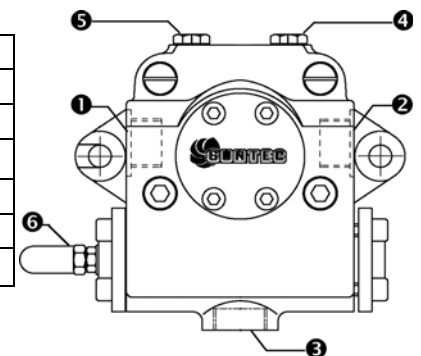

- 1 Inlet G1/2
- 2 To the nozzle G1/2
- 3 Return G1/2
- 4 Pressure gauge port G1/4
- 5 Vacuum gauge port G1/4
- 6 Pressure governor

| | |
|----------------------------|----------------------------|
| HP-Technick UHE-A.. | |
| Oil viscosity | 3 ÷ 75 cSt |
| Oil temperature | 0 ÷ 150°C |
| Min. suction pressure | - 0.45 bar to avoid gasing |
| Max. suction pressure | 5 bar |
| Max. return pressure | 5 bar |
| Rotation speed | 3600 rpm max. |

- 1.Connection for manometer 1 – delivery (M1) – G1/4
- 2.Connection for manometer 2 – suction (M2) – G1/4
- 3.Connection for manometer 3 (M3)
- A. Suction connection– G1/2
- D. Direct - clockwise
- I. Indirect – counter clockwise
- R. By-pass connection– G1/2
- S. Delivery connection – G1/2
- VR. After removal of cover screw: pressure regulation

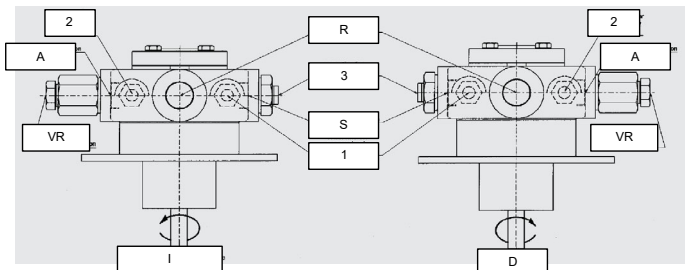

| | |
|-----------------------|---------------------------|
| Danfoss KSM.. | |
| Oil viscosity | 2.5 ÷ 450 cSt |
| Oil temperature | -10 ÷ 160 °C |
| Max. suction pressure | 4 bar |
| Min. suction pressure | -0.45 bar to avoid gasing |
| Max. return pressure | 4 bar |
| Rotation speed | 3450 rpm max |

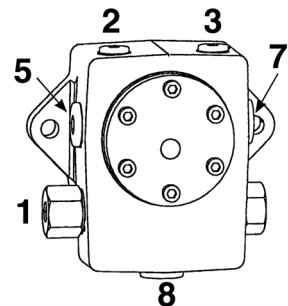

Key

- 1 Pressure governor
- 2 Pressure / vacuum gauge port to measure inlet pressure/vacuum
- 3 Pressure gauge port
- 5 Suction
- 7 To nozzle
- 8 Return

Diesel filters (available on request)







| | Item | Note | Connection | Max. operating pressure | Max. operating temperature | Filtering degree | Protection |
|---|-------------|------|------------|-------------------------|----------------------------|------------------|------------|
| 5 | 20151PE (*) | - | 3/8" | 1 bar | -20, 60 °C | 100 µ | - |
| 6 | 20201PL (*) | - | 3/8" | 1 bar | -20, 60 °C | 100 µ | - |
| 7 | GA70501 | - | 1" | 4 bar | 90 °C | 100 µ | IP65 |

(*) Supplied per pilot diesel fuel if present

Connecting the light oil flexible hoses

To connect the flexible light oil hoses to the pump, proceed as follows, according to the pump provided:

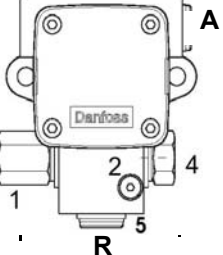
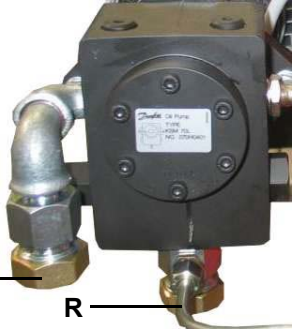
- 1 remove the closing nuts **A** and **R** on the inlet and return connections of the pump;
- 2 screw the rotating nut of the two flexible hoses on the pump **being careful to avoid exchanging the inlet and return lines**: see the arrows marked on the pump that show the inlet and the return (see previous paragraph).

| Suntec AJ6 | Suntec J6 | Danfoss RSB30 |
|--|--|--|
|  |  |  |
| Danfoss KSM | Suntec TA | HP Technik UHE-A |
|  |  |  |

Light oil circuit

The fuel is pushed into the pump 1 to the nozzle 3 at the delivery pressure set by the pressure governor. The solenoid valve 2 set the fuel immission into the combustion chamber. The part of fuel that is not burnt goes back to the tank through the return circuit. The fuel amount to be burnt is adjusted by means of the burner actuator according to the adjustments set (see page 23).

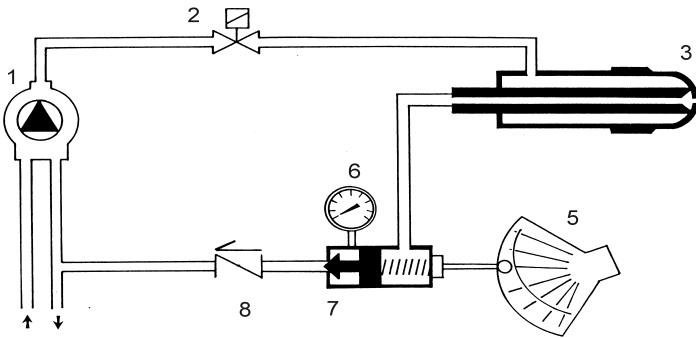

Fig. 6 - Stand-by

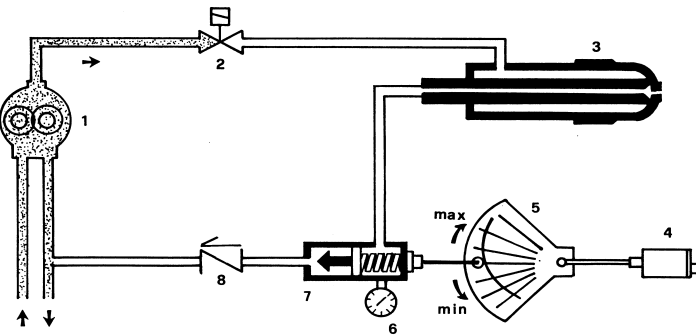

Fig. 7 - Prepurge

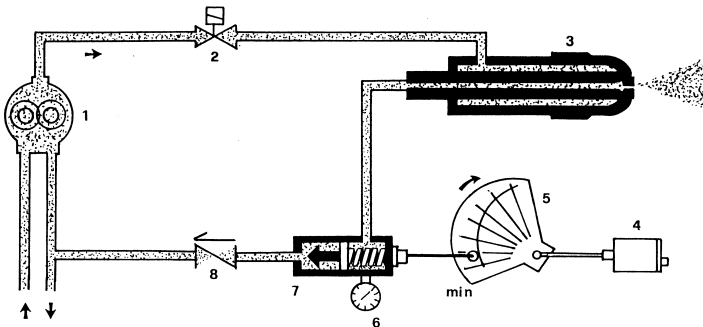

Fig. 8 - Low flame

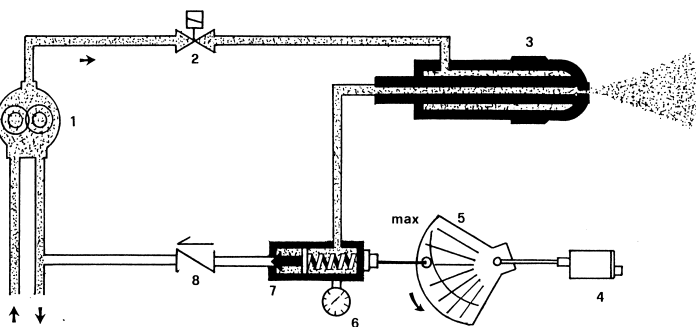
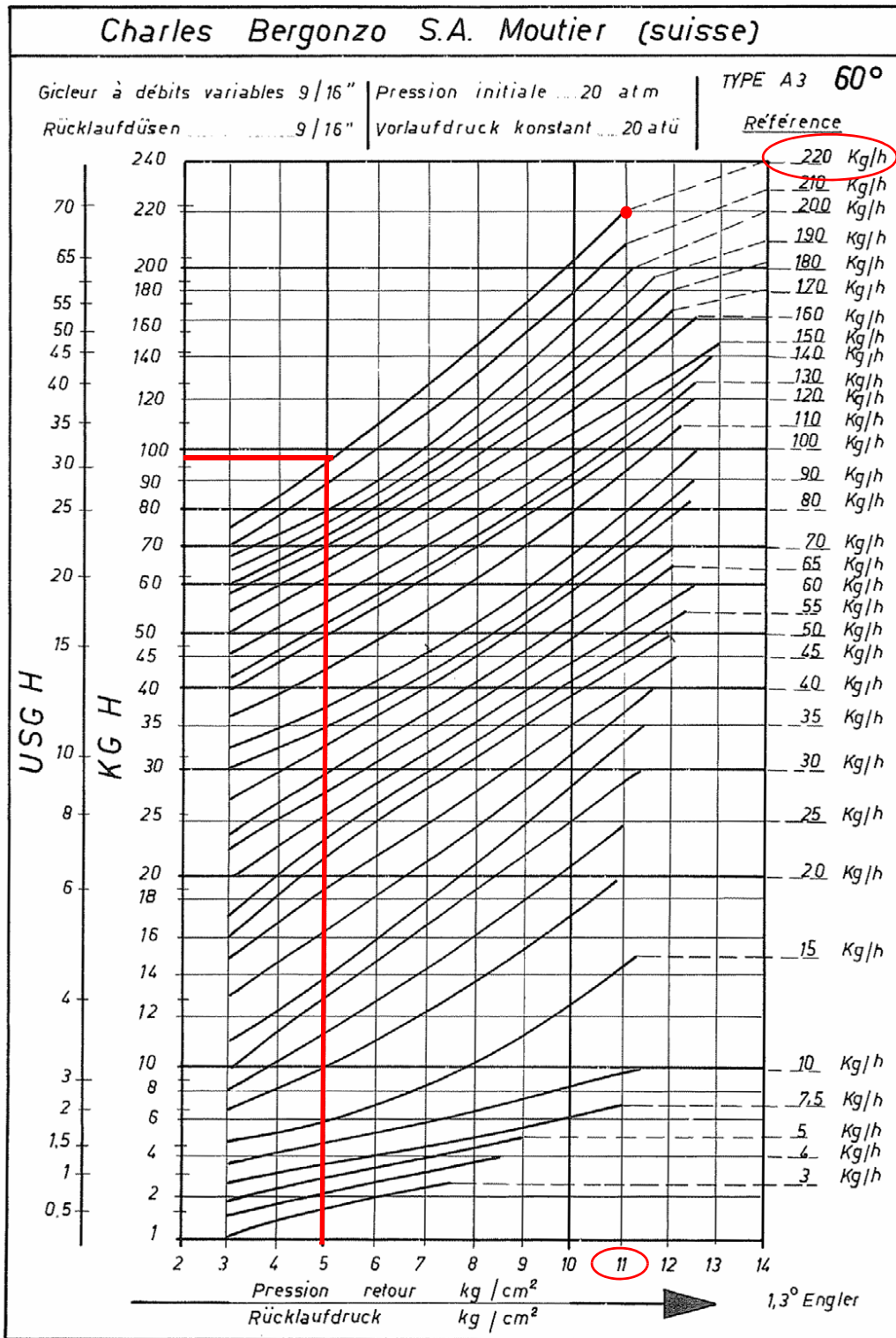

Fig. 9 - High flame

Key

- 1 Light oil pump
- 2 Light oil solenoid valve
- 3 Nozzle
- 4 Servocontrol
- 5 Adjusting cam
- 6 pressure gauge
- 7 Pressure regulator
- 8 One-way valve

The oil flow rate can be adjusted choosing a nozzle that suits the boiler/utilisation output and setting the delivery and return pressure values according to the ones quoted on the following charts.



Example (Bergonzo): if a 220kg/h flow rate BERGONZO nozzle is provided, set the return pressure at 11bar, supply at 20bar on the delivery to get a 220kg/h flow rate. If the return pressure needed is 5bar, instead, act on the **V** adjusting screw on the pressure governor. The flow rate will then be about 95kg/h (see the example showed on the Bergonzo diagram).

FLUIDICS KW3...60°

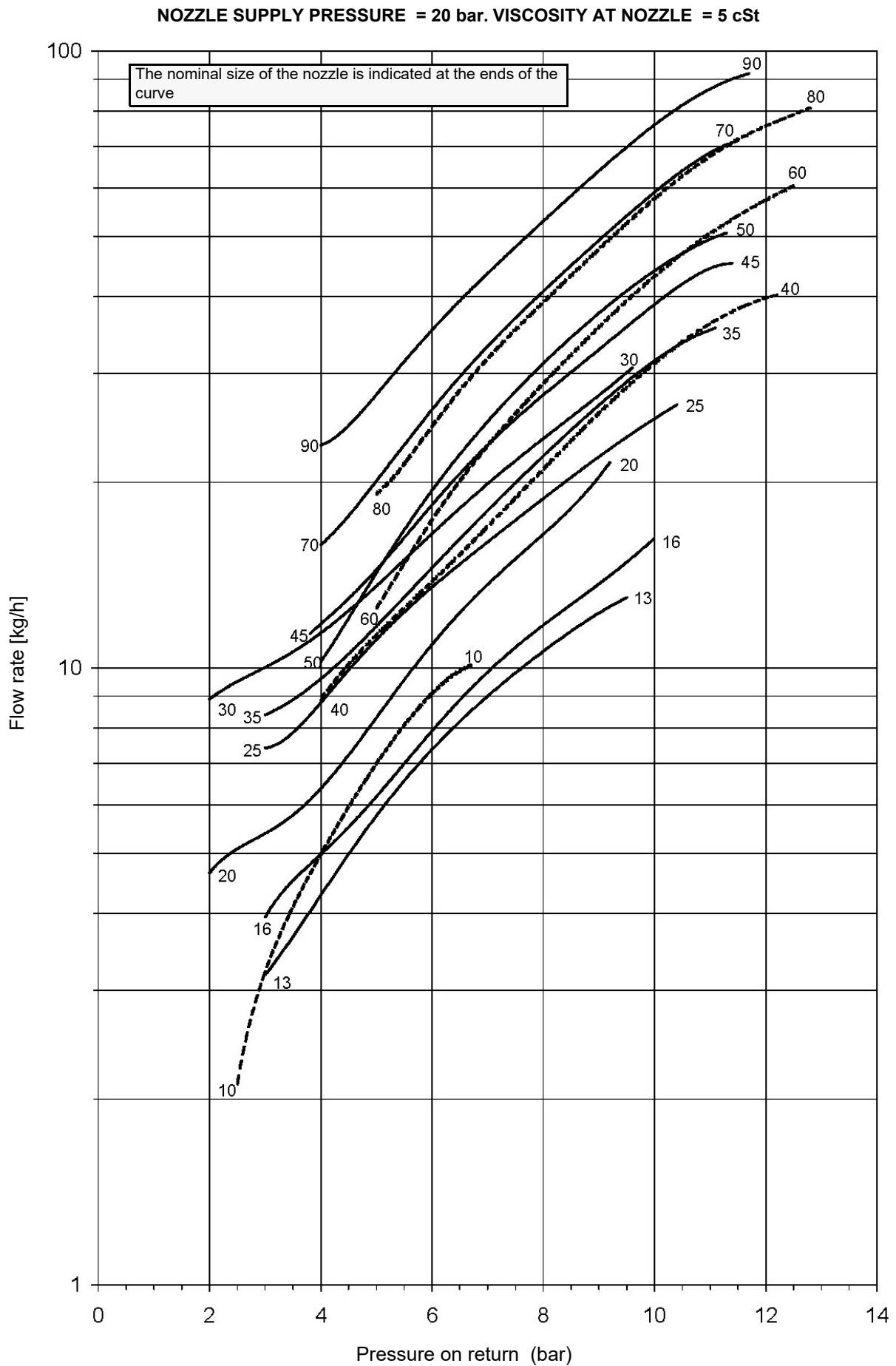

FLUIDICS KW3...60°

NOZZLE SUPPLY PRESSURE = 20 bar. VISCOSITY AT NOZZLE = 5 cSt

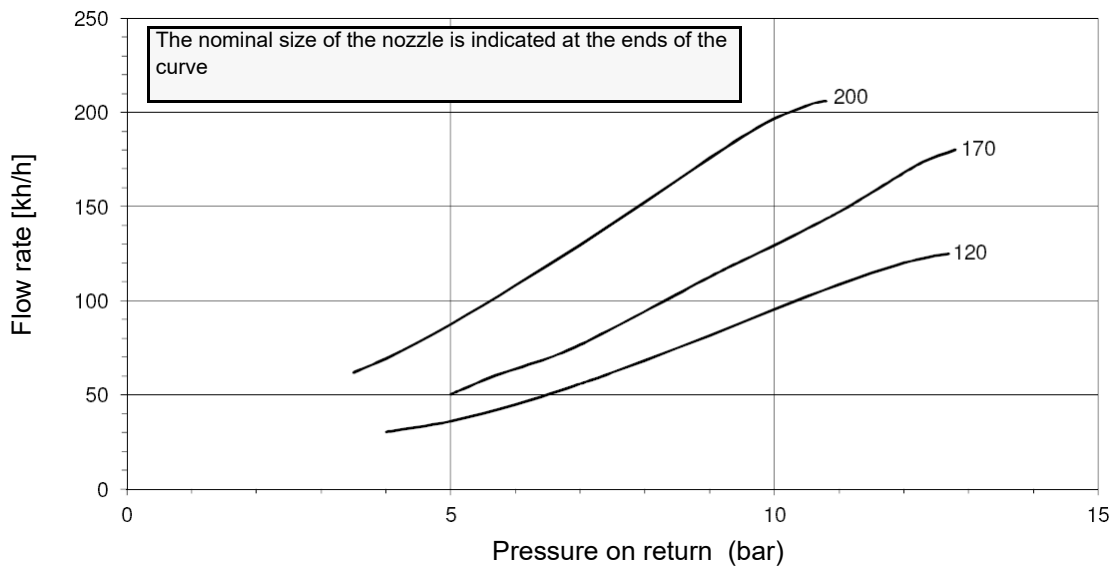
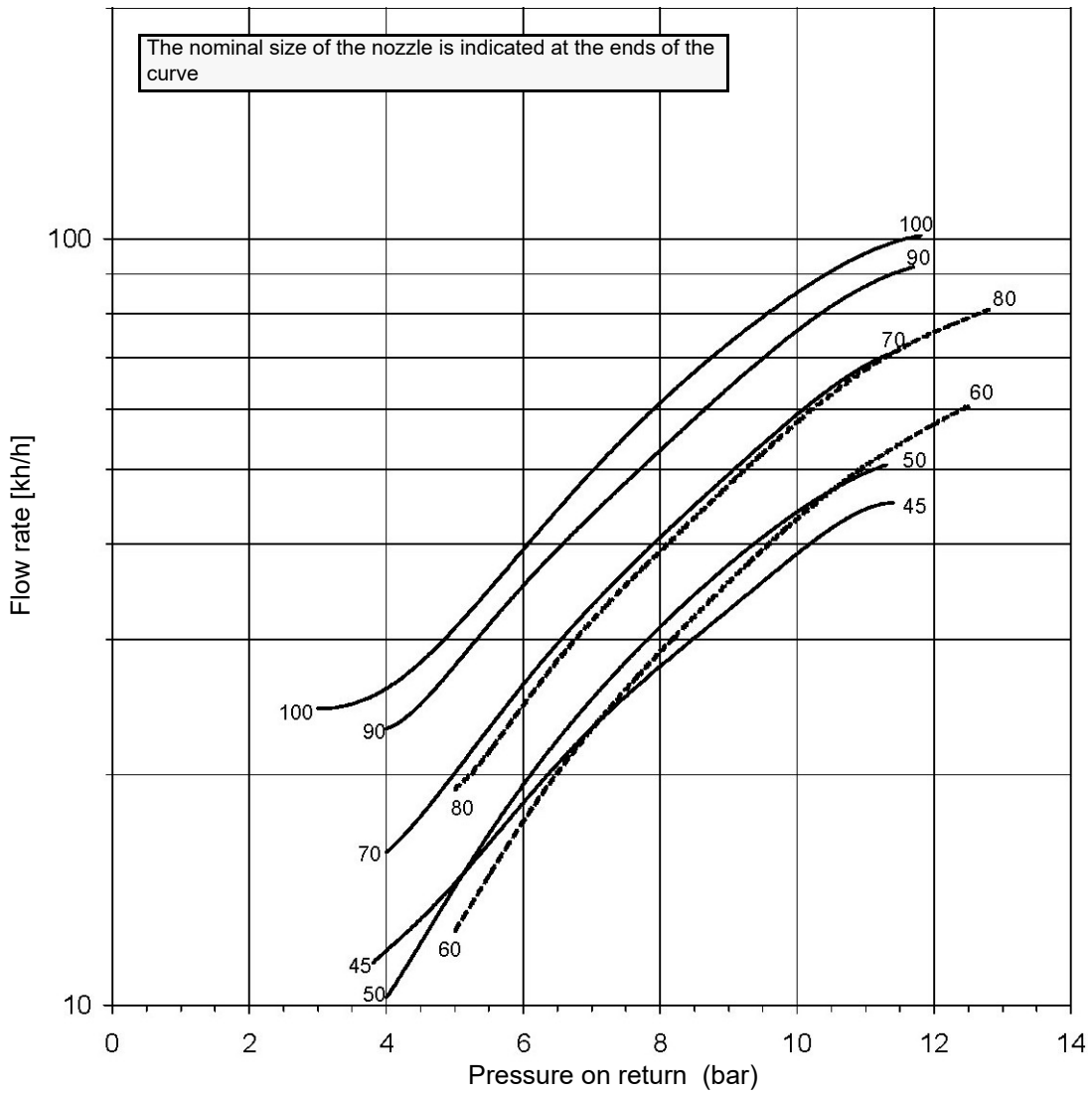

FLUIDICS KW3...60°

NOZZLE SUPPLY PRESSURE = 20 bar. VISCOSITY AT NOZZLE = 5 cSt

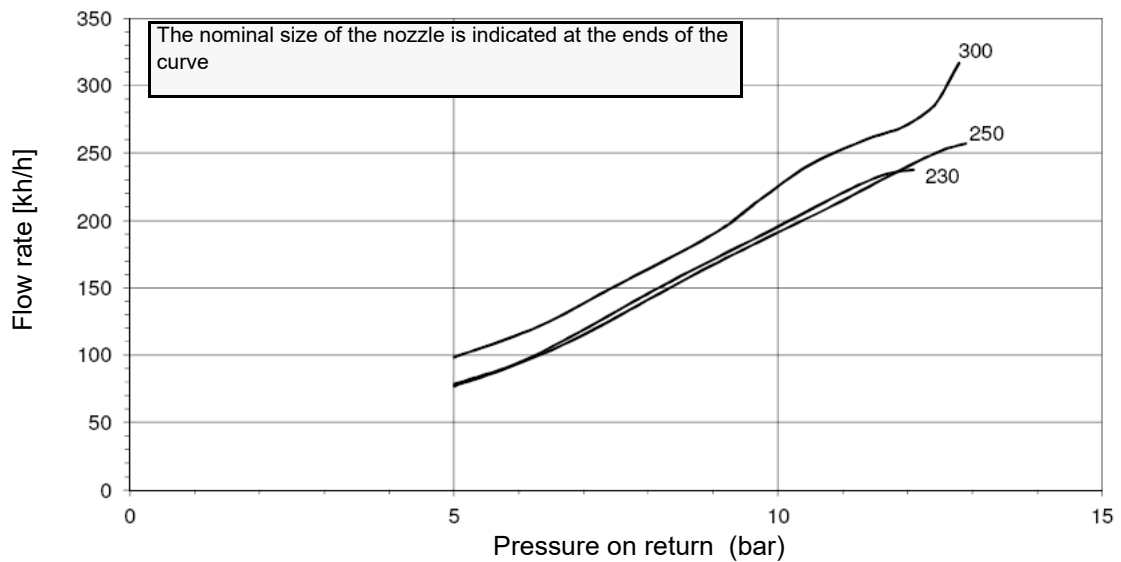
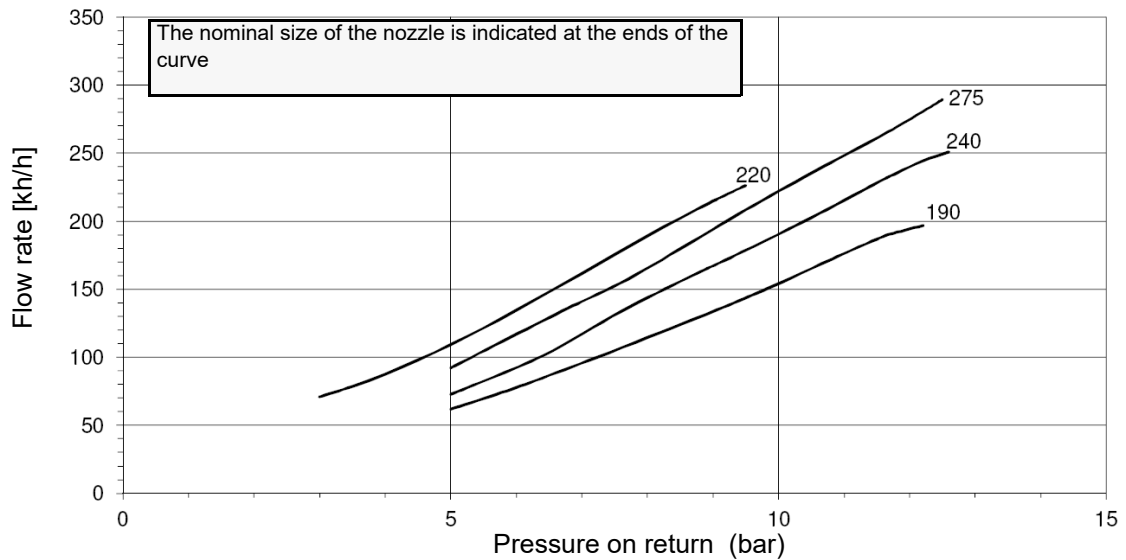
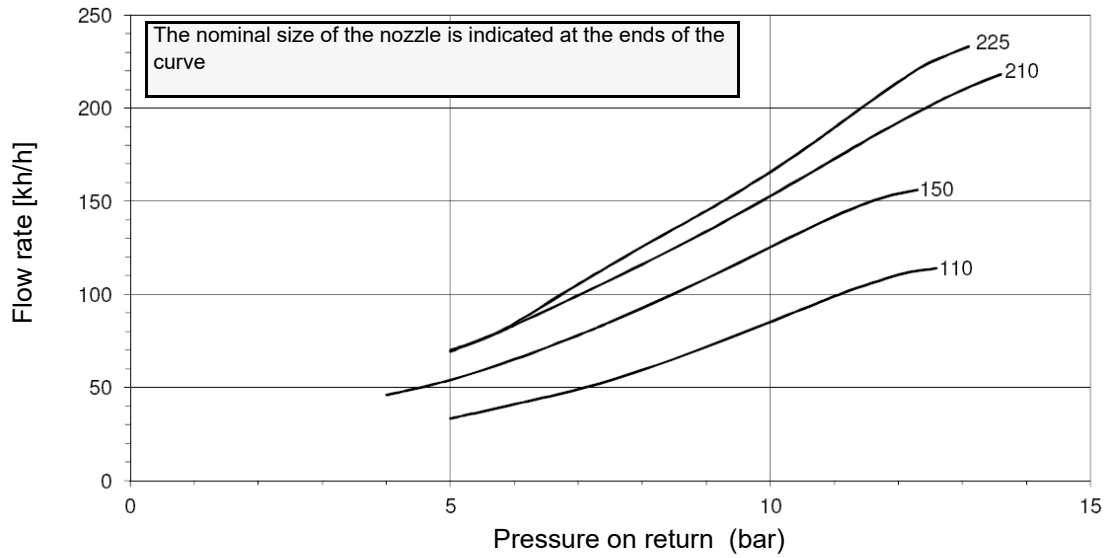

ADJUSTMENTS

Adjustments - brief description

| | |
|--|--|
|  | ATTENTION: before starting the burner up, be sure that the manual cutoff valves are open. Be sure that the mains switch is closed. |
| | Before starting up the burner, make sure that the return pipe to the tank is not obstructed. Any obstruction would cause the pump seal to break. |
| | ATTENTION: During commissioning operations, do not let the burner operate with insufficient air flow (danger of formation of carbon monoxide); if this should happen, make the gas decrease slowly until the normal combustion values are achieved. |

| | |
|---|---|
|  | IMPORTANT! the combustion air excess must be adjusted according to the in the following chart: |
|---|---|

| Recommended combustion parameters | | |
|-----------------------------------|---------------------------------|--------------------------------|
| Fuel | Recommended (%) CO ₂ | Recommended (%) O ₂ |
| Light oil | 11.5 ÷ 13 | 2.9 ÷ 4.9 |

Adjust the air and fuel flow rates at the maximum output ("high flame") first, by means of the air damper and the adjusting cam respectively.

- Check that the combustion parameters are in the suggested limits.
- Then, adjust the combustion values corresponding to the points between maximum and minimum: set the foil shape of the adjusting cam. The adjusting cam sets the air/fuel ratio in those points, regulating the opening-closing of the fuel governor.
- Set, now, the low flame output, acting on the low flame microswitch of the actuator in order to avoid the low flame output increasing too much or that the flues temperature gets too low to cause condensation in the chimney.

Adjustment procedure

To change the burner setting during the testing in the plant, follow the next procedure, according to the actuator model provided (mod. Berger or mod. Siemens).

- PG60: Berger STA12../Siemens SQN72..
- PG70-PG81: Berger STM30.. / Siemens SQM40..

Adjustment by the Berger actuator

- 1 Open the electrical panel to check the motor rotation and act directly on its contactor (see next picture): keep pressed until the oil circuit is charged.

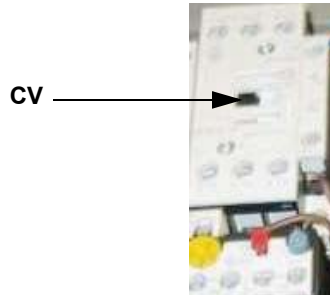

- 2 bleed the air from the **M** pressure gauge port (Fig. 13) by loosening the cap without removing it, then release the contactor.

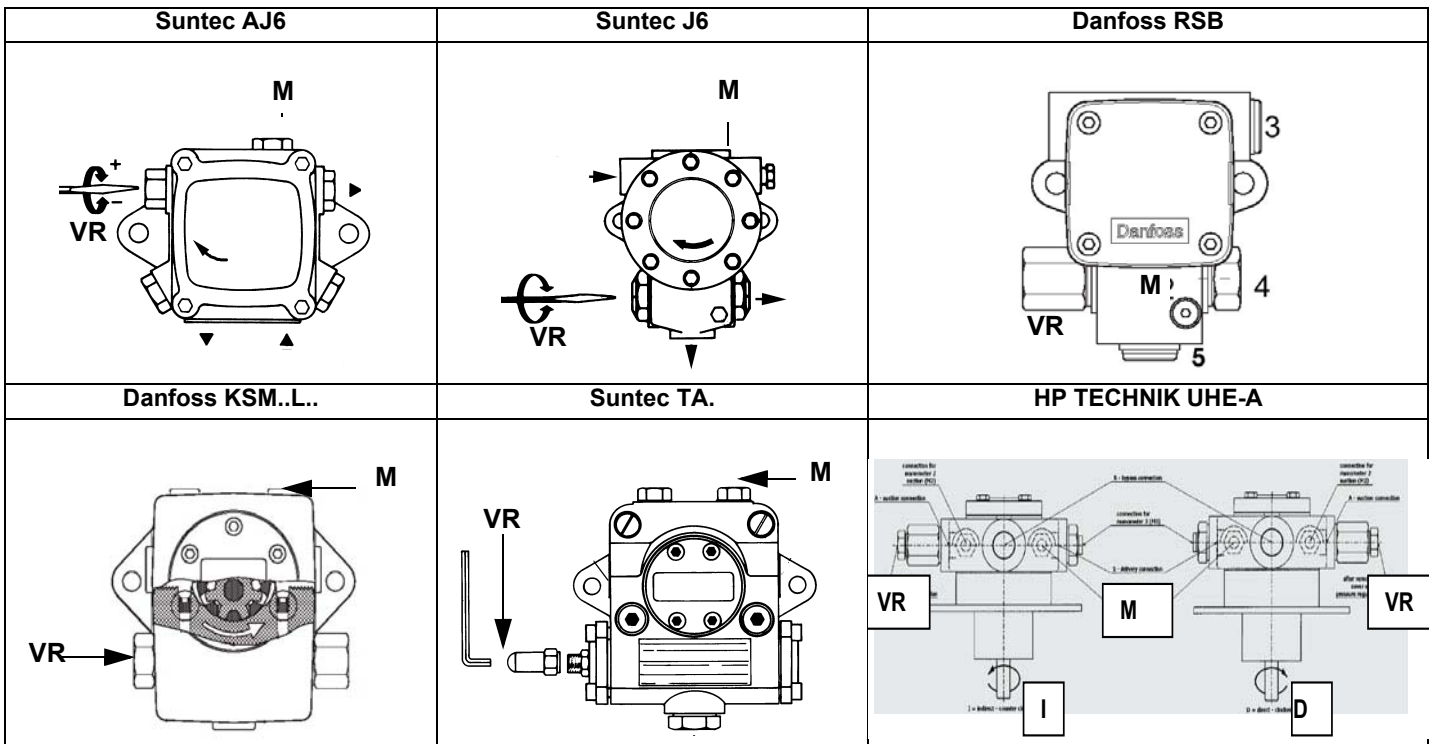
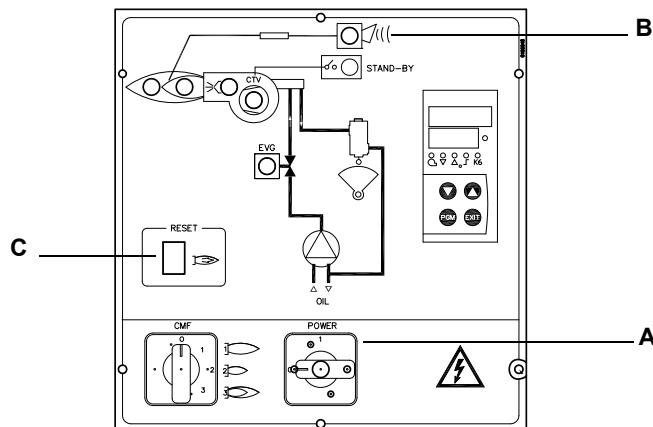

Fig. 13

- 3 Before starting the burner up, drive the high flame actuator microswitch matching the low flame one (in order to let the burner operates at the lowest output) to safely achieve the high flame stage .
- 4 Turn the burner on by means of its main switch **A**: if the burner locks (LED **B** on in the control panel) press the RESET button (**C**) on the control panel (see next picture) - see chapter "OPERATION" on page 29.



- 5 be sure that the actuator cam for the "Startup enabling signal" (when used) is 5° more than the ignition cam;
- 6 start the burner up by means of the thermostat series and wait until the pre-purge time comes to an end;
- 7 drive the burner to high flame stage, by means fo the thermostat **TAB**.

8 Then move progressively the microswitch to higher values until it reaches the high flame position; always check the combustion values and eventually adjusting the oil pressure (see next step).

- PG60: Berger STA12../Siemens SQN72..
- PG70-PG81: Berger STM30.. / Siemens SQM40..
- **Attention:Berger actuator: cams can be moved manually**
- **Siemens actuator: set the MAN/AUTO lever to MAN to move the cams, remember to set it to AUTO once the adjustment is accomplished.**

Berger STA12..

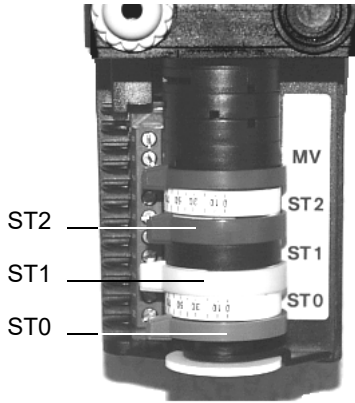

- ST2 High flame
- ST0 Stand-by and Ignition
- ST1 Low flame
- MV Startup enabling signal

Siemens SQN72

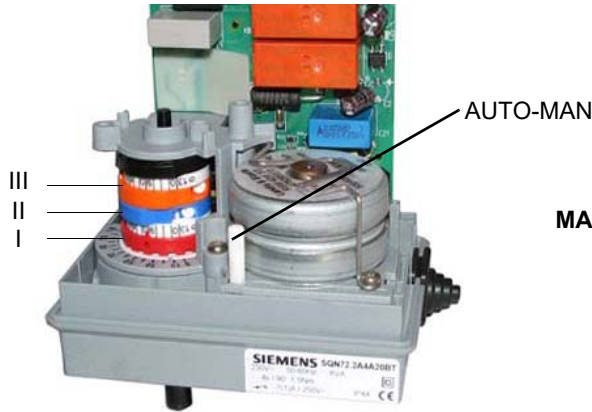

- I = High flame cam
- II = Ignition position
- III = Low flame

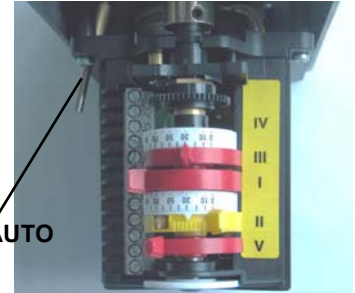

Berger STM30

Actuator cams

- I High flame
- II Stand-by and Ignition
- III Low flame
- V Startup enabling signal

SQM40.265 Actuator cams

Version with flame control LMO 24.255 / 44.255

- (RD) I High flame
- (BU) II Stand-by
- (OG) III Low flame
- (YE) IV -
- (BK) V -
- (GN) VI Advance stroke limitation cam - set +5° to cam (BU) II

Version with flame control LAL 2.25

- (RD) I High flame
- (BU) II Stand-by
- (OG) III Low flame
- (YE) IV -
- (BK) V -
- (GN) VI -

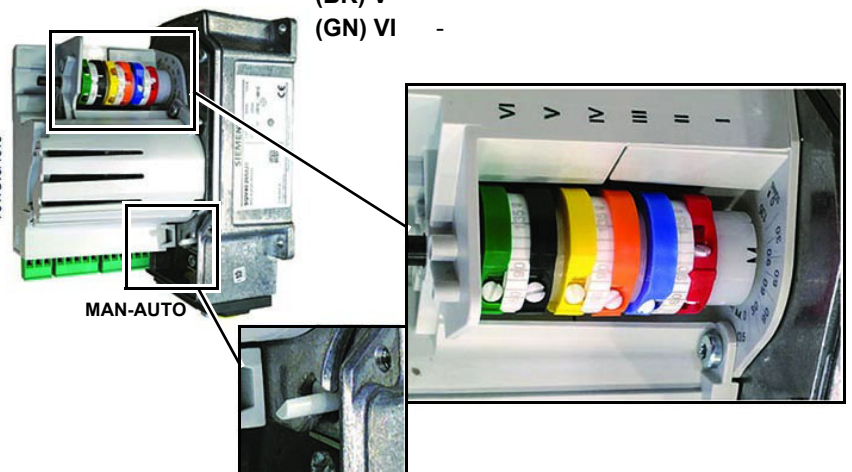
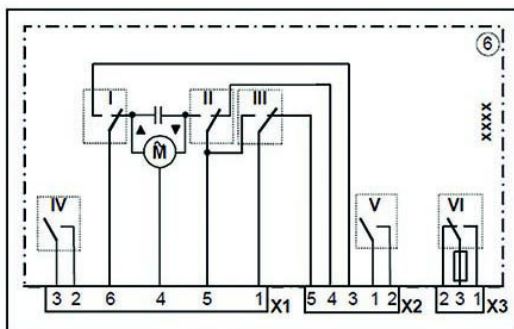

9 the nozzle supply pressure is already factory-set and must not be changed. Only if necessary, adjust the supply pressure as follows (see related paragraph);insert a pressure gauge into the port shown on Fig. 14-Fig. 15 and act on on the pump adjusting screw **VR** (see Fig. 13) as to get the nozzle pressure at 20bar (Bergonzo nozzles - see diagram on Fig. 10).

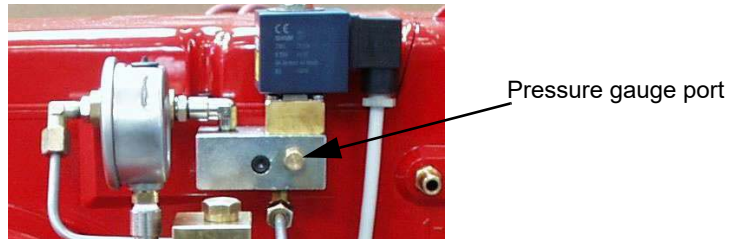

Fig. 14 - Light oil manifold (PG60)

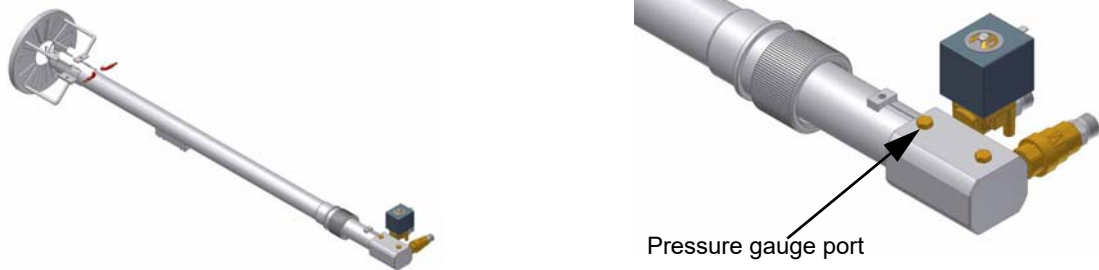

Fig. 15 - Combustion head with light oil gun (PG70 - PG81)

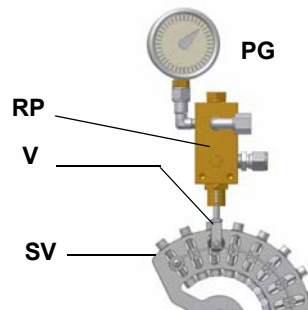
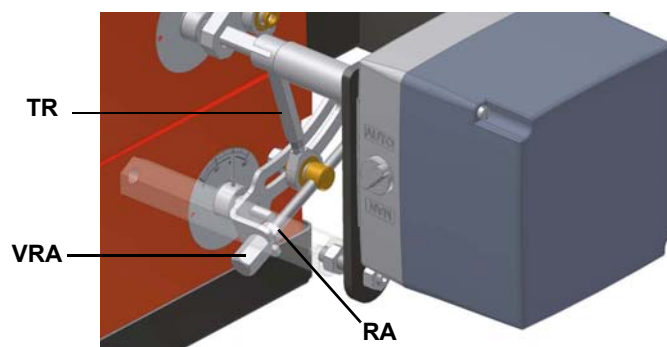

Fig. 16

- 10 in order to get the maximum oil flow rate, adjust the pressure (reading its value on the **PG** pressure gauge: checking always the combustion parameters, the adjustment is to be performed by means of the **SV** adjusting cam screw (see picture Fig. 16) when the cam has reached the high flame position.
- 11 To adjust the **air flow rate in the high flame stage**, loose the **RA** nut and screw **VRA** as to get the desired air flow rate: moving the rod **TR** towards the air damper shaft, the air damper opens and consequently the air flow rate increases, moving it far from the shaft the air damper closes and the air flow rate decreases.

Note: once the procedure is performed, be sure that the blocking nut **RA** is fasten. Do not change the position of the air damper rods.



- 12 The burner is factory-set with the head in its **MAX** position (maximum output).

PG60:

To let the burner operate at a lower output, turn clockwise the **VRT** screw and move progressively the combustion head back towards the **MIN** position.

PG70-PG81:

To let the burner operate at a lower output, loose the **VB** screw and move progressively the combustion head back towards the **MIN**

position, by turning clockwise the **VRT** ring nut. Fasten **VB** screw when the adjustment is accomplished.

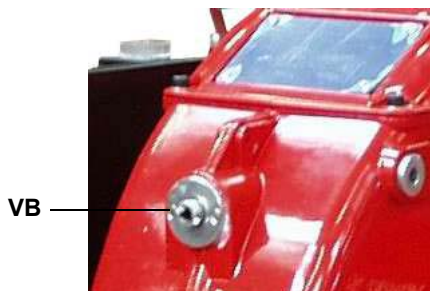

PG60

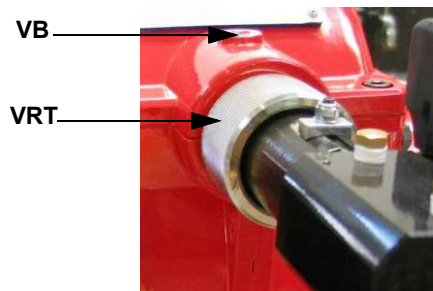

PG70-PG81



"MIN" position

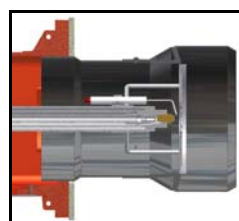

"MAX" position

Attention! if it is necessary to change the head position, repeat the air and gas adjustments described above.

- 13 the air and oil rate are now adjusted at the maximum power stage, go on with the point to point adjustment on the **SV** adjusting cam as to reach the minimum output point.

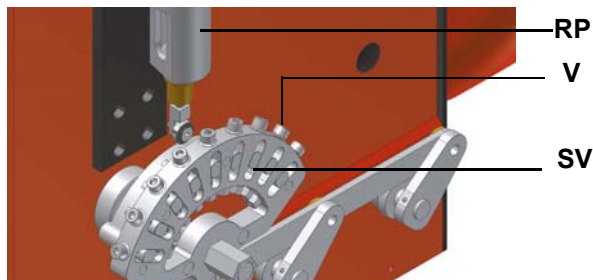
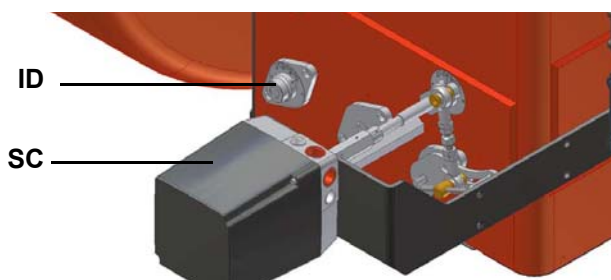

- 14 as for the point-to-point regulation in order to set the cam foil shape, move the low flame microswitch (cam III) a little lower than the maximum position (90°);
- 15 set the **TAB** thermostat to the minimum in order that the actuator moves progressively towards the low flame position;
- 16 move cam III (low flame) towards the minimum to move the actuator towards the low flame until the two bearings find the adjusting screw that refers to a lower position: screw **V** to increase the rate, unscrew to decrease, in order to get the pressure as showed on diagram in Fig. 10, according to the requested rate.
- 17 Move again cam III towards the minimum to meet the next screw on the adjusting cam and repeat the previous step; go on this way as to reach the desired low flame point.
- 18 The low flame position must never match the ignition position that is why cam III must be set 20°- 30° more than the ignition position.

Turn the burner off; then start it up again. If the adjustment is not correct, repeat the previous steps.

Oil pressure switch adjustment

Follow the below instruction, according to the pressure switch installed.

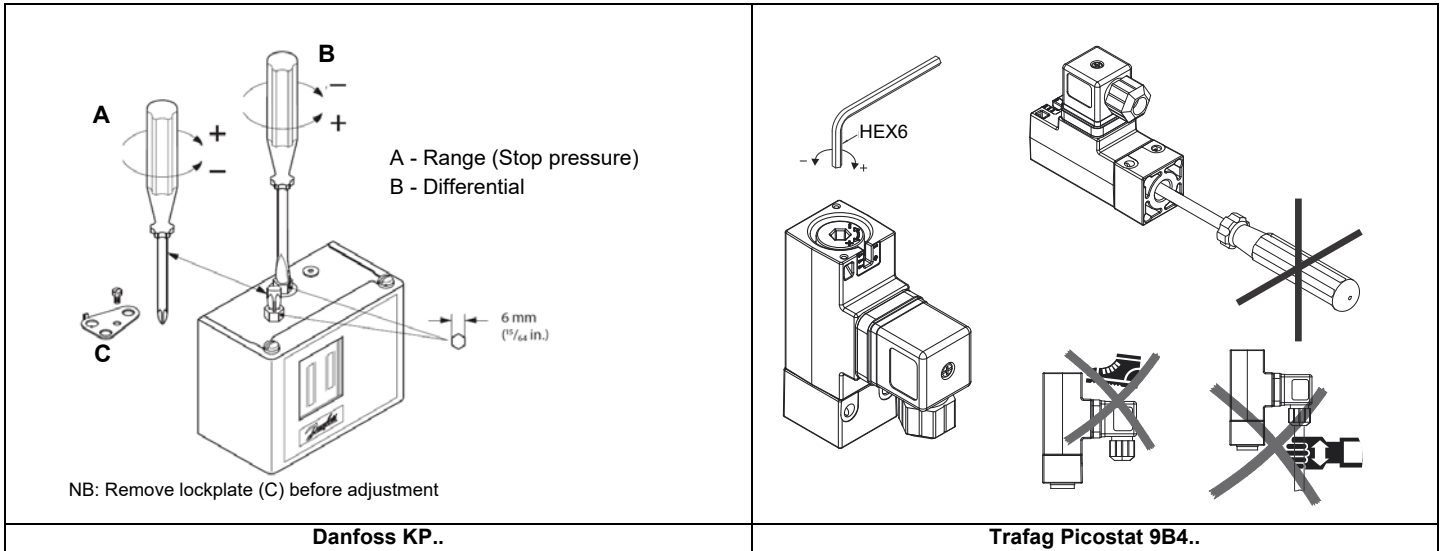

Minimum oil pressure switch (when provided)

The minimum oil pressure switch on the inlet line, checks that the pressure does not drop below a default value. The pressure switch must be set, say, at 10% under the pressure at the nozzle.

Maximum oil pressure switch

The oil pressure switch on the return line, checks that the pressure does not exceed a default value. This value must not be higher than the maximum acceptable pressure on the return line (this value is reported on the specification table). A pressure change on the return line could affect the combustion parameters: for this reason, the pressure switch must be set, say, at 20% over the pressure recorded during the combustion adjustment. The factory setting is 4 bar.

It is recommended to verify that the combustion parameters are within the range of acceptable values even against a pressure variation that gets close to the limit of the pressure switch.

This check should be carried out along the whole range of the burner output.

In case of unacceptable values, reduce from 20% to 15% the overpressure; later on, repeat the adjustments described above.

Fully-modulating burners

To adjust the fully-modulating burners, use the **CMF** switch on the burner control panel (see next picture), instead of the **TAB** thermostat as described on the previous paragraphs about the progressive burners. Go on adjusting the burner as described before, paying attention to use the CMF switch instead of **TAB**.

The **CMF** position sets the operating stages: to drive the burner to the high-flame stage, set CMF=1; to drive it to the low-flame stage, set CMF=2.

To move the adjusting cam set CMF=1 or 2 and then CMF=0.

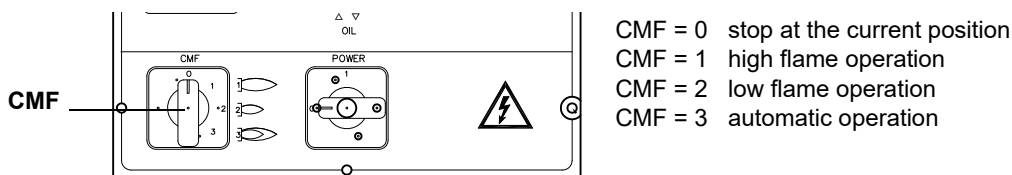

Calibration of air pressure switch (when provided)

To calibrate the air pressure switch, proceed as follows:

- Remove the transparent plastic cap.
- Once air and gas setting have been accomplished, startup the burner.
- During the pre-purge phase of the operation, turn slowly the adjusting ring nut **VR** in the clockwise direction (to increase the adjusting pressure) until the burner locks out, then read the value on the pressure switch scale and set it to a value reduced by 15%.
- Repeat the ignition cycle of the burner and check it runs properly.
- Refit the transparent plastic cover on the pressure switch.

PART II: OPERATION

LIMITATIONS OF USE

THE BURNER IS AN APPLIANCE DESIGNED AND CONSTRUCTED TO OPERATE ONLY AFTER BEING CORRECTLY CONNECTED TO A HEAT GENERATOR (E.G. BOILER, HOT AIR GENERATOR, FURNACE, ETC.), ANY OTHER USE IS TO BE CONSIDERED IMPROPER AND THEREFORE DANGEROUS.

THE USER MUST GUARANTEE THE CORRECT FITTING OF THE APPLIANCE, ENTRUSTING THE INSTALLATION OF IT TO QUALIFIED PERSONNEL AND HAVING THE FIRST COMMISSIONING OF IT CARRIED OUT BY A SERVICE CENTRE AUTHORIZED BY THE COMPANY MANUFACTURING THE BURNER.

A FUNDAMENTAL FACTOR IN THIS RESPECT IS THE ELECTRICAL CONNECTION TO THE GENERATOR'S CONTROL AND SAFETY UNITS (CONTROL THERMOSTAT, SAFETY, ETC.) WHICH GUARANTEES CORRECT AND SAFE FUNCTIONING OF THE BURNER.

THEREFORE, ANY OPERATION OF THE APPLIANCE MUST BE PREVENTED WHICH DEPARTS FROM THE INSTALLATION OPERATIONS OR WHICH HAPPENS AFTER TOTAL OR PARTIAL TAMPERING WITH THESE (E.G. DISCONNECTION, EVEN PARTIAL, OF THE ELECTRICAL LEADS, OPENING THE GENERATOR DOOR, DISMANTLING OF PART OF THE BURNER).

NEVER OPEN OR DISMANTLE ANY COMPONENT OF THE MACHINE.

OPERATE ONLY THE MAIN SWITCH, WHICH THROUGH ITS EASY ACCESSIBILITY AND RAPIDITY OF OPERATION ALSO FUNCTIONS AS AN EMERGENCY SWITCH, AND ON THE RESET BUTTON.

IN CASE OF A BURNER SHUT-DOWN, RESET THE CONTROL BOX BY MEANS OF THE RESET PUSHBUTTON. IF A SECOND SHUT-DOWN TAKES PLACE, CALL THE TECHNICAL SERVICE, WITHOUT TRYING TO RESET FURTHER.

WARNING: DURING NORMAL OPERATION THE PARTS OF THE BURNER NEAREST TO THE GENERATOR (COUPLING FLANGE) CAN BECOME VERY HOT, AVOID TOUCHING THEM SO AS NOT TO GET BURNT.

OPERATION



ATTENTION: before starting the burner up, be sure that the manual cutoff valves are open and check that the mains switch is closed.

- 1 Set to the ON position the switch A on the control panel of the burner.
- 2 Check the control box is not in the lockout position (light **B** must be off); in such a case reset it by the reset pushbutton **C**.
- 3 Check the series of thermostats (or pressure switches) sends the burner the signal to operate.
- 4 The startup sequence begins: the control box ignites the fan motor and energises the ignition transformer as well (signalled by the light **H** on the burner control panel).
- 5 At the end of the pre-purge stage, the light oil solenoid valve EVG1 is energised (signalled by the lamp **G** on the control panel) and the burner is on.
- 6 The ignition transformer is energized for few seconds after the ignition of the flame (post-ignition time) and at the end of this time is de-energised (light **H** off).
- 7 After the ignition the servocontrol moves to the high flame position for some seconds, then the operation begins and the burner switches to high flame or to low flame, according to the plant demand.
- 8 The high/low flame operation is showed by the **F** LED turning on/off.

Burner control panel

PG60

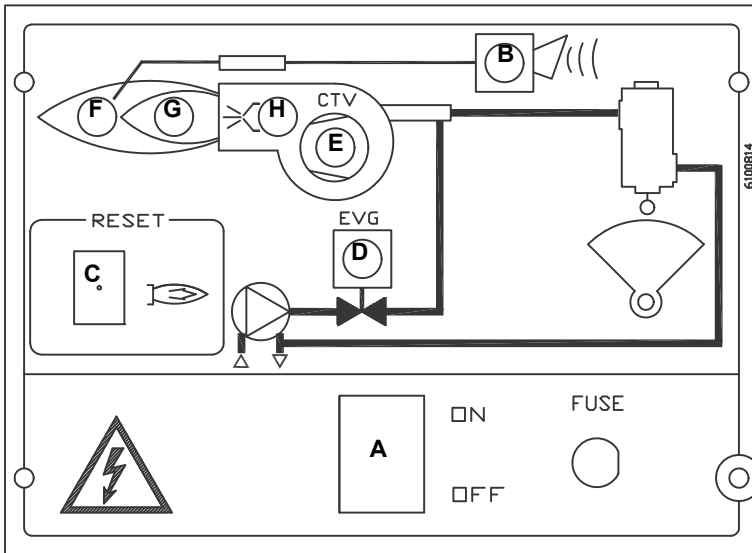

Fig. 17



P

PG70-PG81

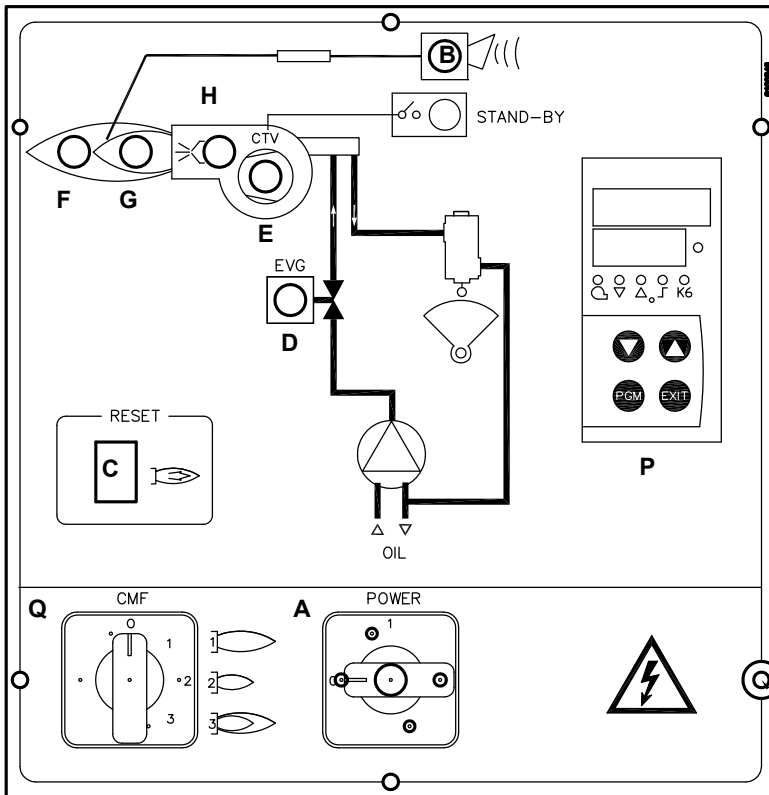

Fig. 18



P

Keys

- A ON-OFF main switch
- B Lockout signalling lamp
- C Conreol box release pushbutton
- D Signalling lamp for light oil solenoid valve opening
- E Thermal cutout intervention signalling lamp
- F High flame operation signalling lamp
- G Low flame operation signalling lamp
- H Ignition transformer operation signalling lamp
- P Siemens modulator
- Q Manual operation mode switch

PART III: MAINTENANCE

At least once a year carry out the maintenance operations listed below. In the case of seasonal servicing, it is recommended to carry out the maintenance at the end of each heating season; in the case of continuous operation the maintenance is carried out every 6 months.



WARNING: ALL OPERATIONS ON THE BURNER MUST BE CARRIED OUT WITH THE MAINS DISCONNECTED AND THE FUEL MANUAL CUTOFF VALVES CLOSED!

ATTENTION: READ CAREFULLY THE "WARNINGS" CHAPTER AT THE BEGINNING OF THIS MANUAL.

ROUTINE MAINTENANCE

- Check and clean the cartridge of the fuel filter, replace it if necessary (see next paragraph);
- carefully check for leaks, the fuel flexible hoses;
- check and clean the filter on the fuel pump: filter must be thoroughly cleaned at least once in a season to ensure correct working of the fuel unit. To remove the filter, unscrew the four screws on the cover. When reassemble, make sure that the filter is mounted with the feet toward the pump body. If the gasket between cover and pump housing should be damaged, it must be replaced;
- remove, check and clean the combustion head (page 32); when reassembling, carefully observe the measures on page 32;
- check the ignition electrodes and their ceramic insulators, clean, adjust and replace if necessary;
- remove and clean the oil nozzles (IMPORTANT: do not clean the nozzles using metallic or sharp utensils, use only solvents or steam); at the end of maintenance operations, refit the burner, turn it on and check the combustion. If in doubt, replace the defective nozzle/s. In case of intensive use of the burner, the nozzles must be replaced at the end of the working season;
- check and carefully clean the flame detection photoresistor, if necessary replace it and, if in doubt, check the detection current following the diagram on page 34;
- clean and grease levers and rotating parts.

Light oil filter maintenance

For correct and proper servicing, proceed as follows:

- 1 shut off fuel in the line section being serviced;
- 2 unscrew the tray;
- 3 remove the filter cartridge from its support and wash it with petrol or replace if necessary; check seal O-Ring, replace if necessary;
- 4 reassemble the tray and restore fuel flow.



Removing the combustion head and the oil gun

- 1 Remove the top cover **C**;
- 2 remove the photoresistor from its seat;
- 3 unscrew the revolving connectors (**E** in figure) on the fuel pipes (use 2 spanners to avoid loosening the connections attached to the distributor block);
- 4 loosen **VRT** screw to free the threaded rod **AR**, then screw out the 2 screws **V** holding the washer **R** and the screw **VRT** again;
- 5 remove the whole assembly as shown in the pictures;
- 6 clean the combustion head and the oil gun by means of a vacuum cleaner; to scrape off the scale use a metallic brush.

Note: to replace the combustion head reverse the procedure described above.

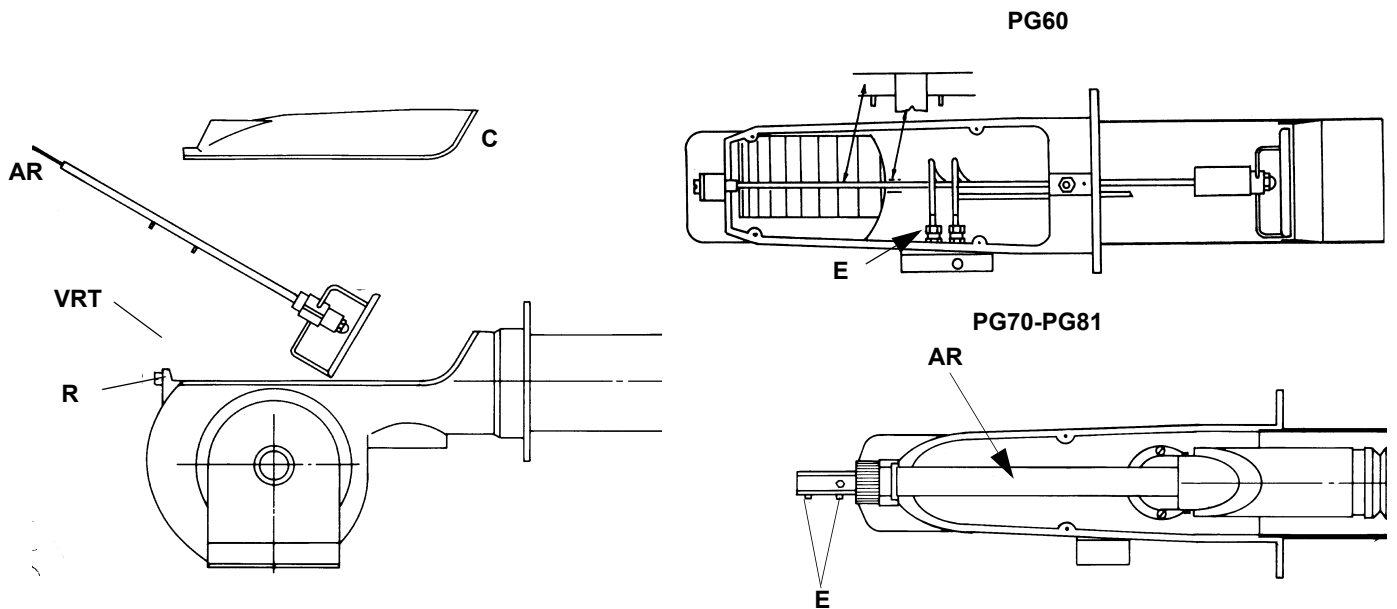

Fig. 19

Removing the oil gun (PG70-PG81)

Once the combustion head is removed, as described before, remove the oil gun as follows:

- 1 unscrew the connectors from the 2 oil pipes (**E** in figure) using 2 spanners to avoid loosening the connections attached to the distributor block);
- 2 loosen the screw **VB**
- 3 remove the gun with the light oil nozzle holder.
- 4 clean the oil gun by means of a vacuum cleaner; to scrape off the scale use a metallic brush
- 5 replace the oil gun, if necessary.

Note: To re-assemble, follow the procedure above in reversed order.

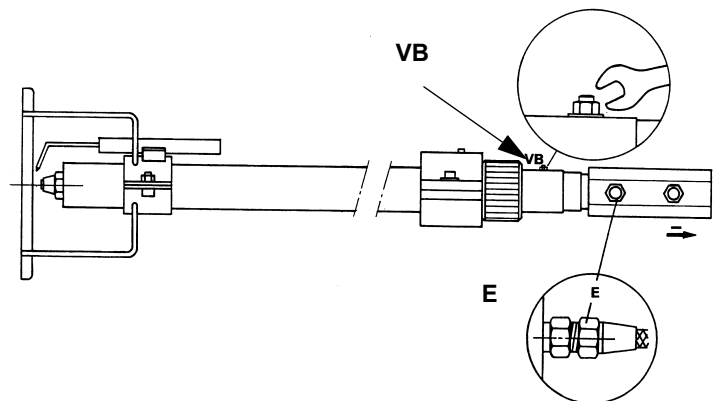

Fig. 20

Correct position of electrodes and combustion head



ATTENTION: avoid the electrodes to get in touch with metallic parts (blast tube, head, etc.), otherwise the boiler operation would be compromised. Check the electrodes position after any intervention on the combustion head.

To guarantee a good ignition the measures shown on the next picture Fig. 21 must be observed.
Be sure to tight the screw on the electrodes group before reassembling the combustion head.

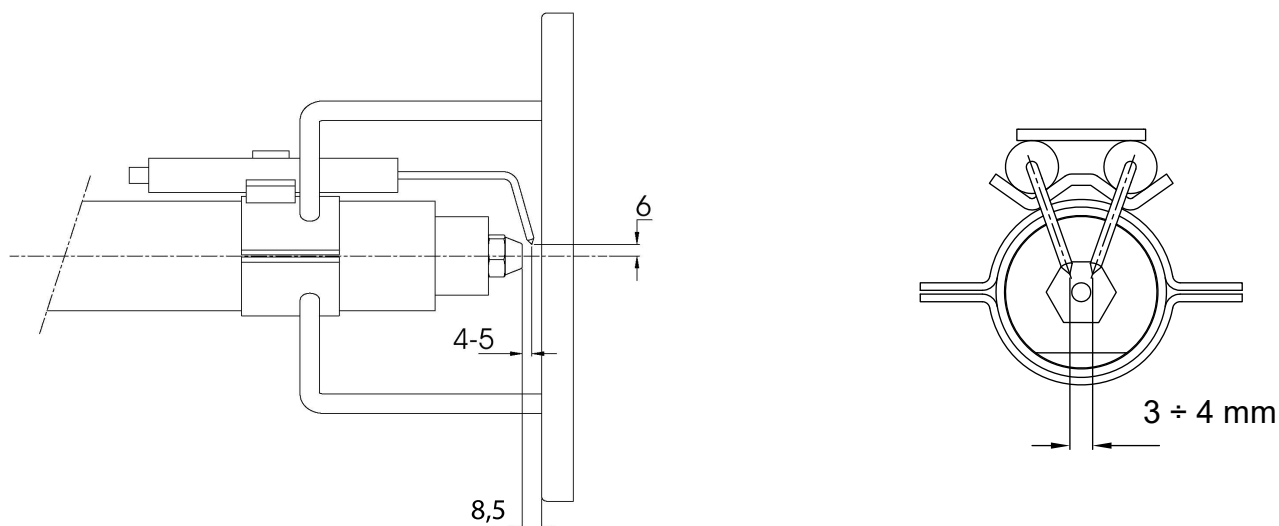

Fig. 21

Replacing the ignition electrodes



ATTENTION: avoid the electrodes to get in touch with metallic parts (blast tube, head, etc.), otherwise the boiler operation would be compromised. Check the electrodes position after any intervention on the combustion head.

To replace the ignition electrodes, proceed as follows:

- 1 remove the burner cover;
- 2 disconnect the electrodes cables;
- 3 remove the combustion head (see par. "Removing the combustion head");
- 4 loose screw that fasten the ignition electrodes;
- 5 remove the electrodes and replace them, referring to the values quoted on Fig. 21.

Cleaning and replacing the detection photoresistor

To clean/replace the photoresistor, proceed as follows:

- 1 disconnect the system from the electrical power supply;
- 2 shut off the fuel supply;
- 3 remove the photoresistor from its slot;
- 4 clean it using a clean cloth; do not use any burner cleansing sprays;
- 5 if necessary, replace it;
- 6 insert the photoresistor into its slot.

Checking the detection current

To measure the detection signal follow the diagram on the next picture. If the signal is not in the advised range, check the electrical contacts, the cleaning of the combustion head, the position of the photoresistor and if necessary replace it.

| Control box | Flame sensor | Minimum detection signal |
|-------------|--------------|--------------------------|
| LMO44 | QRB4 | 45 μ A |
| LAL2.. | QRB1 | 95 μ A |

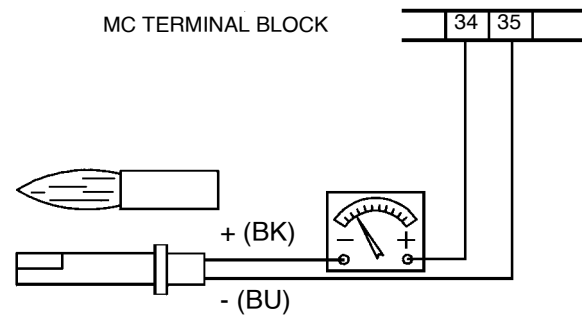

Fig. 22

Seasonal stop

To stop the burner in the seasonal stop, proceed as follows:

- 1 turn the burner's main switch to 0 (Off position)
- 2 disconnect the power mains
- 3 close the fuel manual valve of the supply line

Burner disposal

In case of disposal, follow the instructions according to the laws in force in your country about the "Disposal of materials".

TROUBLESHOOTING

| | THE BURNER DOESN'T START | THE BURNER REPEATS PRE-PURGE | NOISY FUEL PUMP | THE BURNER DOESN'T START AND STOPS | THE BURNER STARTS AND STOPS | THE BURNER DOESN'T SWITCH TO HIGH FLAME | THE BURNER STOPS DURING OPERATION | THE BURNER STOPS AND REPEATS THE CYCLE DURING OPERATION |
|--|--------------------------|------------------------------|-----------------|------------------------------------|-----------------------------|---|-----------------------------------|---|
| MAIN SWITCH OPEN | ● | | | | | | | |
| LINE FUSE INTERVENTION | ● | | | | | | | |
| MAX. PRESSURE SWITCH FAULT | ● | | | | | | | ● |
| FAN THERMAL CUTOUT INTERVENTION | ● | | | | | | | |
| AUXILIARY RELAIS FUSES INTERVENTION | ● | | | | | | | |
| CONTROL BOX FAULT | ● | ● | | ● | ● | | ● | |
| SERVOCONTROL FAULT | | | | | | ● | | |
| SMOKEY FLAME | | | | | ● | | ● | |
| IGNITION TRANSFORMER FAULT | | | | ● | | | | |
| IGNITION ELECTRODE DIRTY OR WRONG POSITIONED | | | | ● | | | | |
| DIRTY NOZZLE | | | | ● | | | ● | |
| FUEL SOLENOID VALVE DEFECTIVE | | | | ● | | | ● | |
| PHOTORESISTOR DIRTY OR DEFECTIVE | | | | | ● | | ● | |
| HI-LO FLAME THERMOSTAT DEFECTIVE | | | | | | ● | | |
| WRONG POSITION OF SERVOCONTROL CAMS | | | | | | ● | | |
| FUEL PRESSURE TOO LOW | | | | ● | | | | |
| DIRTY FUEL FILTERS | | | ● | ● | | | ● | |

ELECTRICAL WIRING DIAGRAMS

Wiring diagram 05-556 - Progressive Burners - PG60

Wiring diagram 05-1022 - Fully-modulating Burners - PG60

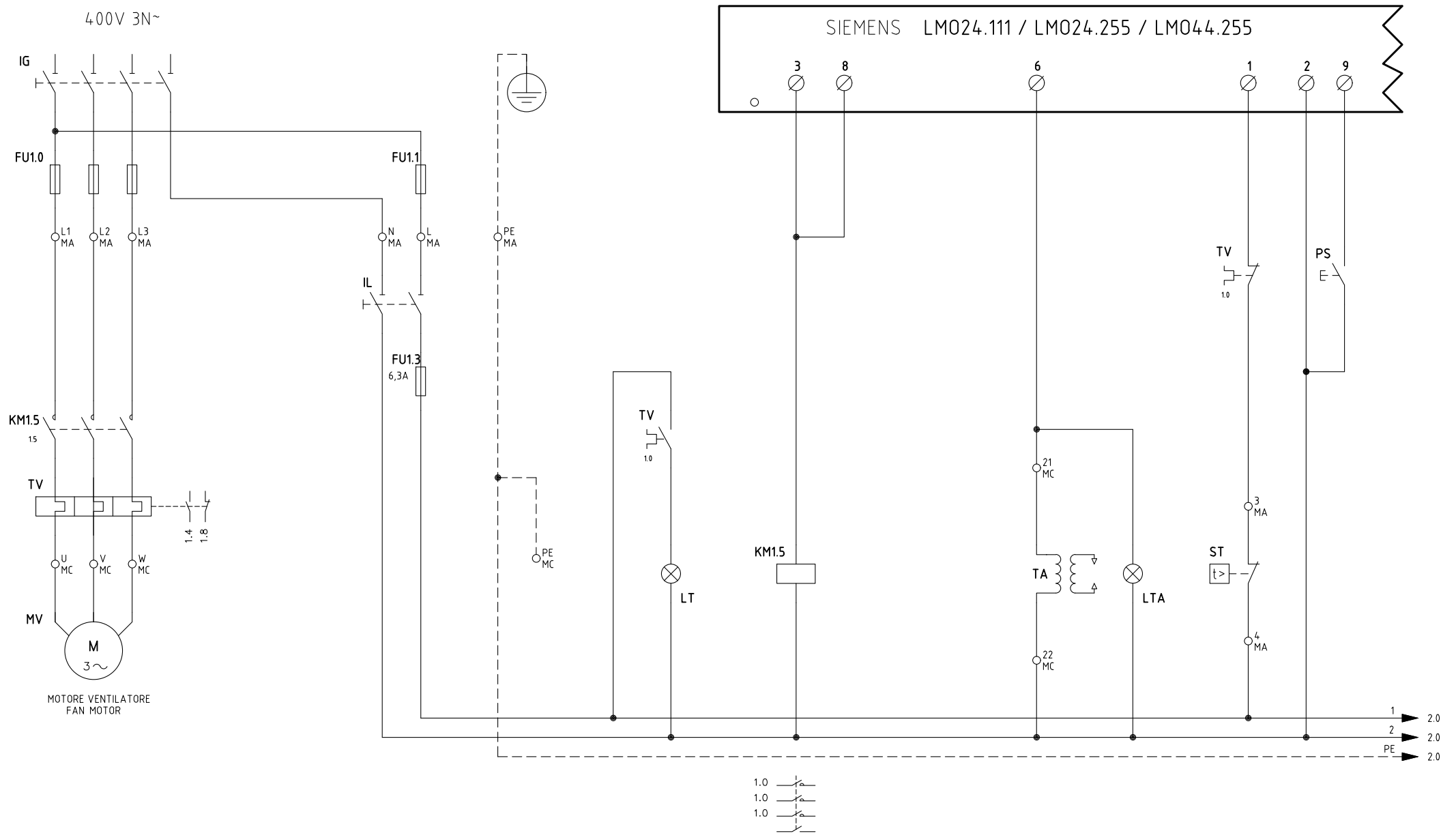

| | | | |
|-----------|------------|-------|--------|
| Data | 03/07/1997 | PREC. | FOGLIO |
| Revisione | 06 | / | 1 |
| Dis. N. | 05 - 0556 | SEGUE | TOTALE |
| | | 2 | 4 |

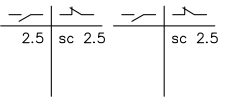
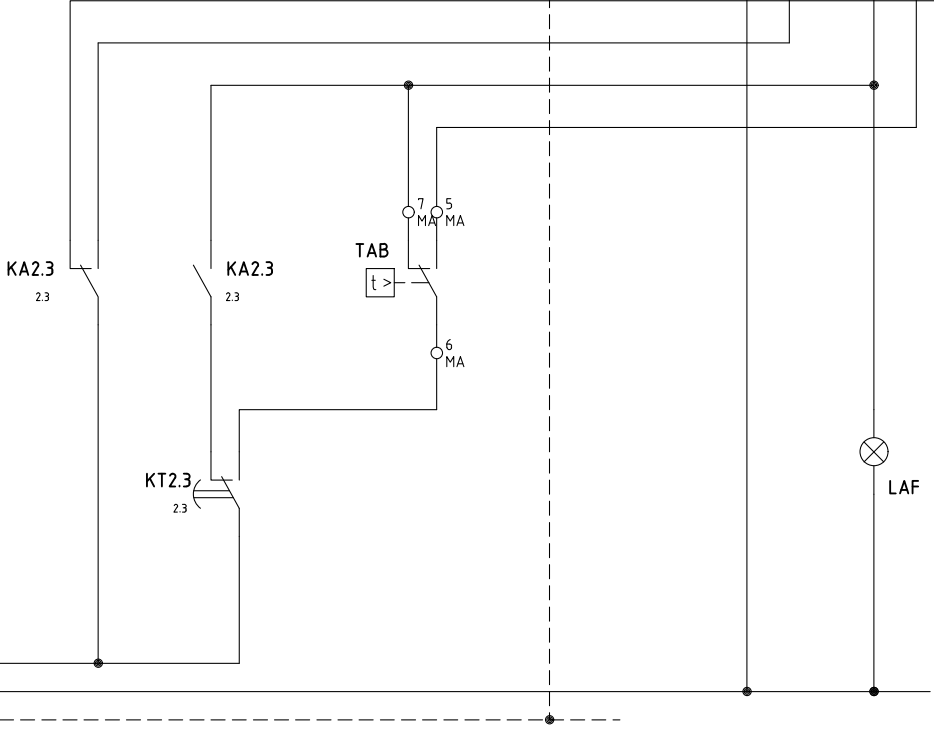
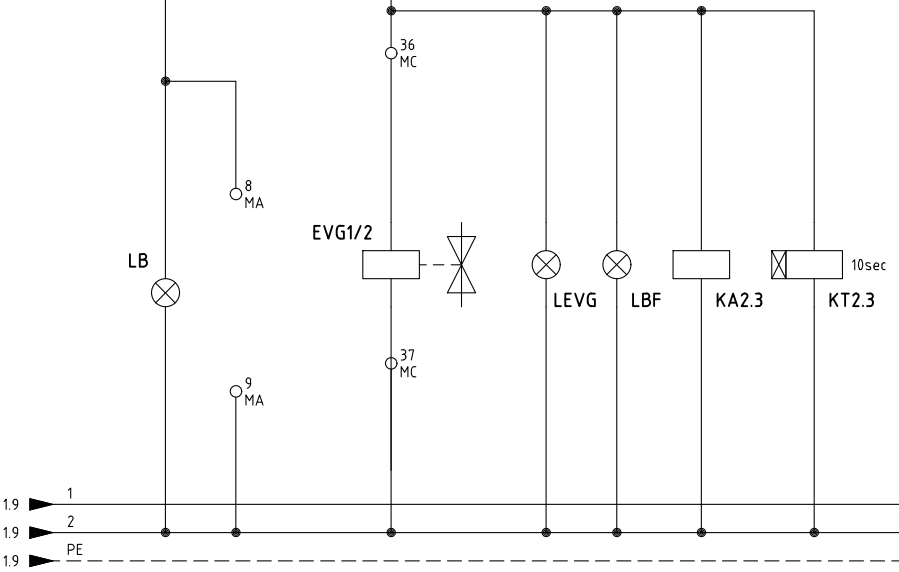
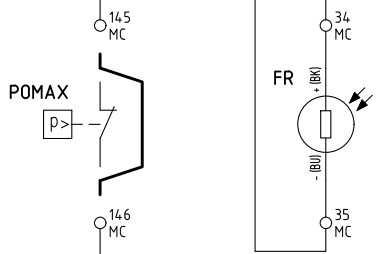
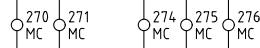
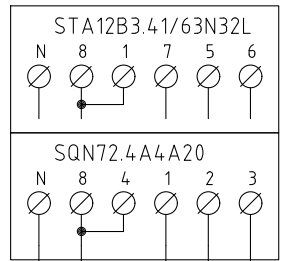
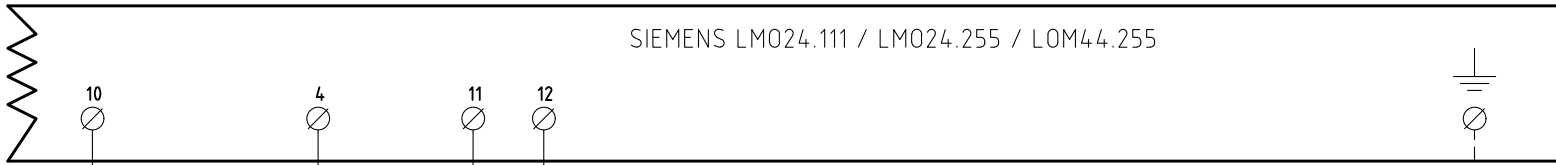

| | | | |
|-----------|------------|-------|--------|
| Data | 03/07/1997 | PREC. | FOGLIO |
| Revisione | 06 | 1 | 2 |
| Dis. N. | 05 - 0556 | SEGUE | TOTALE |
| | | 3 | 4 |

QUADRO QG - MORSETTIERA MA
 MORSETTIERA ALIMENTAZIONE
 SUPPLY TERMINAL BOARD

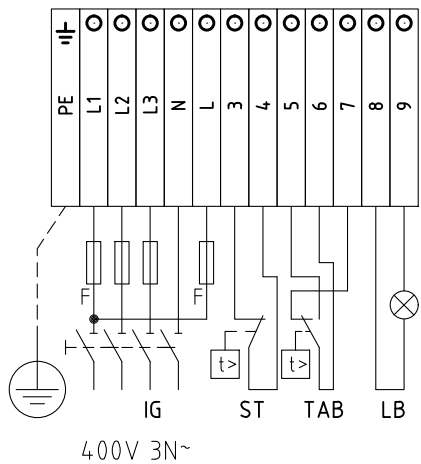

SERVOCOMANDO SERRANDA ARIA
 AIR DAMPER ACTUATOR
 BERGER STA12B3.41/63N32L

- ST2 ALTA FIAMMA
HIGH FLAME
- ST0 SOSTA E ACCENSIONE
STAND-BY AND IGNITION
- ST1 BASSA FIAMMA
LOW FLAME

QUADRO QG - MORSETTIERA MC
 MORSETTIERA COMPONENTI BRUCIATORE
 BURNER COMPONENT TERMINAL BOARD

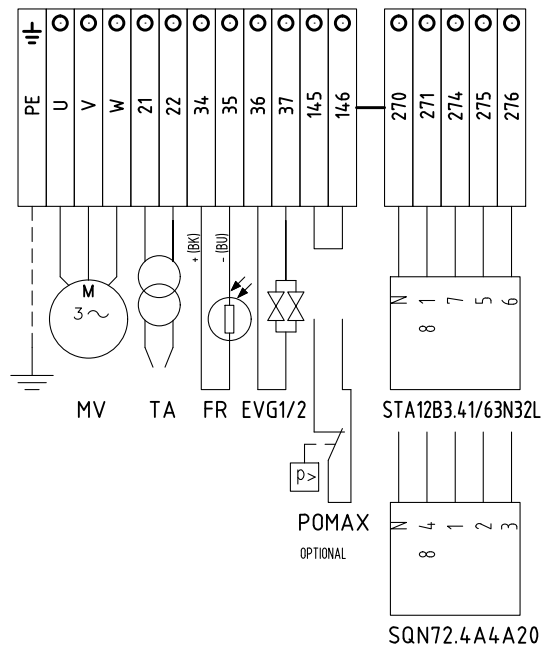

SERVOCOMANDO SERRANDA ARIA (ALTERNATIVO)
 AIR DAMPER ACTUATOR (ALTERNATIVE)
 SIEMENS SQN72.4A4A20

- I (ROSSO) ALTA FIAMMA
I (RED) HIGH FLAME
- II (BLU) SOSTA E ACCENSIONE
II (BLUE) STAND-BY AND IGNITION
- III (ARANCIO) BASSA FIAMMA
III (ORANGE) LOW FLAME

| | | | |
|-----------|------------|-------|--------|
| Data | 03/07/1997 | PREC. | FOGLIO |
| Revisione | 06 | 2 | 3 |
| Dis. N. | 05 - 0556 | SEGUE | TOTALE |
| | | 4 | 4 |

| SIGLA/ITEM | FOGLIO/SHEET | FUNZIONE | FUNCTION |
|-----------------------------------|--------------|--|--|
| EVG1/2 | 2 | ELETTROVALVOLE GASOLIO | LIGHT OIL ELECTRO VALVE |
| FR | 2 | FOTORESISTENZA RILEVAZIONE FIAMMA | PHOTORESISTOR FLAME DETECTOR |
| FU1.0 | 1 | FUSIBILI DI LINEA | LINE FUSES |
| FU1.1 | 1 | FUSIBILE DI LINEA | LINE FUSE |
| FU1.3 | 1 | FUSIBILE LINEA AUSILIARI | AUXILIARY LINE FUSE |
| IG | 1 | INTERRUTTORE GENERALE | MAINS SWITCH |
| IL | 1 | INTERRUTTORE LINEA AUSILIARI | AUXILIARY LINE SWITCH |
| KA2.3 | 2 | RELE' AUSILIARIO | AUXILIARY RELAY |
| KM1.5 | 1 | CONTATTORE MOTORE VENTILATORE | FAN MOTOR CONTACTOR |
| KT2.3 | 2 | RELE' TEMPORIZZATORE | DELAYED RELAY |
| LAF | 2 | LAMPADA SEGNALAZIONE ALTA FIAMMA BRUCIATORE | BURNER IN HIGH FLAME INDICATOR LIGHT |
| LB | 2 | LAMPADA SEGNALAZIONE BLOCCO FIAMMA | BURNER LOCK-OUT INDICATOR LIGHT |
| LBF | 2 | LAMPADA SEGNALAZIONE BASSA FIAMMA BRUCIATORE | BURNER IN LOW FLAME INDICATOR LIGHT |
| LEVG | 2 | LAMPADA SEGNALAZIONE APERTURA EVG | INDICATOR LIGHT FOR OPENING OF ELECTRO-VALVE EVG |
| LM024.111 / LM024.255 / LM044.255 | 1 | APPARECCHIATURA CONTROLLO FIAMMA | CONTROL BOX |
| LT | 1 | LAMPADA SEGNALAZIONE BLOCCO TERMICO MOTORE VENTILATORE | INDICATOR LIGHT FOR FAN OVERLOAD TRIPPED |
| LTA | 1 | LAMPADA SEGNALAZIONE TRASFORMATORE DI ACCENSIONE | IGNITION TRANSFORMER INDICATOR LIGHT |
| MV | 1 | MOTORE VENTILATORE | FAN MOTOR |
| POMAX | 2 | PRESSOSTATO DI MASSIMA PRESSIONE OLIO (OPTIONAL) | MAXIMUM OIL PRESSURE SWITCH (OPTIONAL) |
| PS | 1 | PULSANTE SBLOCCO FIAMMA (SOLO CON LM024) | LOCK-OUT RESET BUTTON (LM024 ONLY) |
| SQN72.4A4A20 | 2 | SERVOCOMANDO SERRANDA ARIA (ALTERNATIVO) | AIR DAMPER ACTUATOR (ALTERNATIVE) |
| ST | 1 | SERIE TERMOSTATI/PRESSOSTATI | SERIES OF THERMOSTATS OR PRESSURE SWITCHES |
| STA12B3.41/63N32L | 2 | SERVOCOMANDO SERRANDA ARIA | AIR DAMPER ACTUATOR |
| TA | 1 | TRASFORMATORE DI ACCENSIONE | IGNITION TRANSFORMER |
| TAB | 2 | TERMOSTATO/PRESSOSTATO ALTA-BASSA FIAMMA | HIGH-LOW THERMOSTAT/PRESSURE SWITCHES |
| TV | 1 | TERMICO MOTORE VENTILATORE | FAN MOTOR THERMAL |

| | | | |
|-----------|------------|-------|--------|
| Data | 03/07/1997 | PREC. | FOGLIO |
| Revisione | 06 | 3 | 4 |
| Dis. N. | 05 - 0556 | SEGUE | TOTALE |
| | | / | 4 |

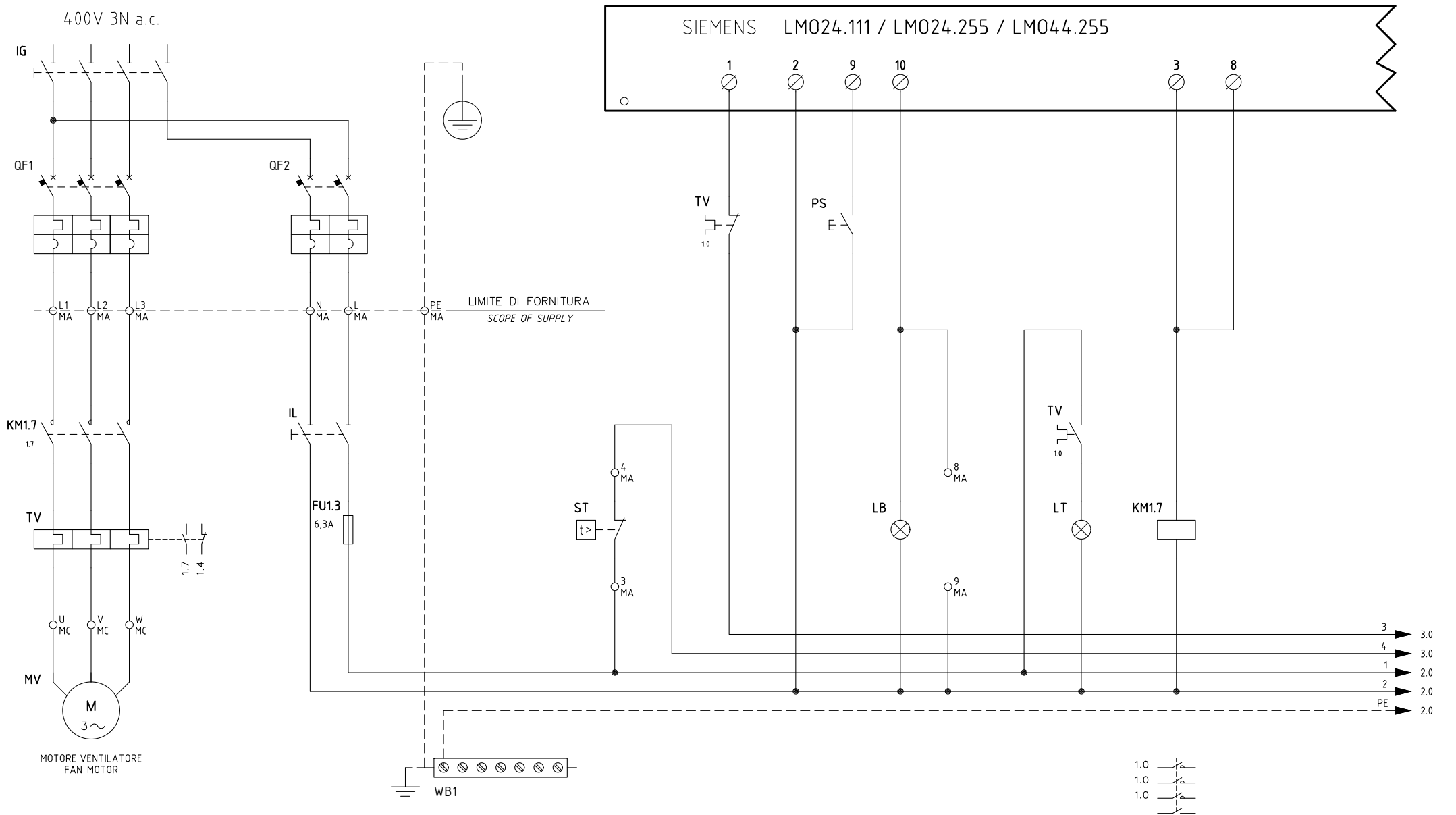

| | | | |
|-----------|------------|-------|--------|
| Data | 26/03/2014 | PREC. | FOGLIO |
| Revisione | 01 | / | 1 |
| Dis. N. | 05 - 1022 | SEGUE | TOTALE |
| | | 2 | 6 |

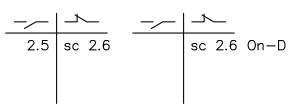
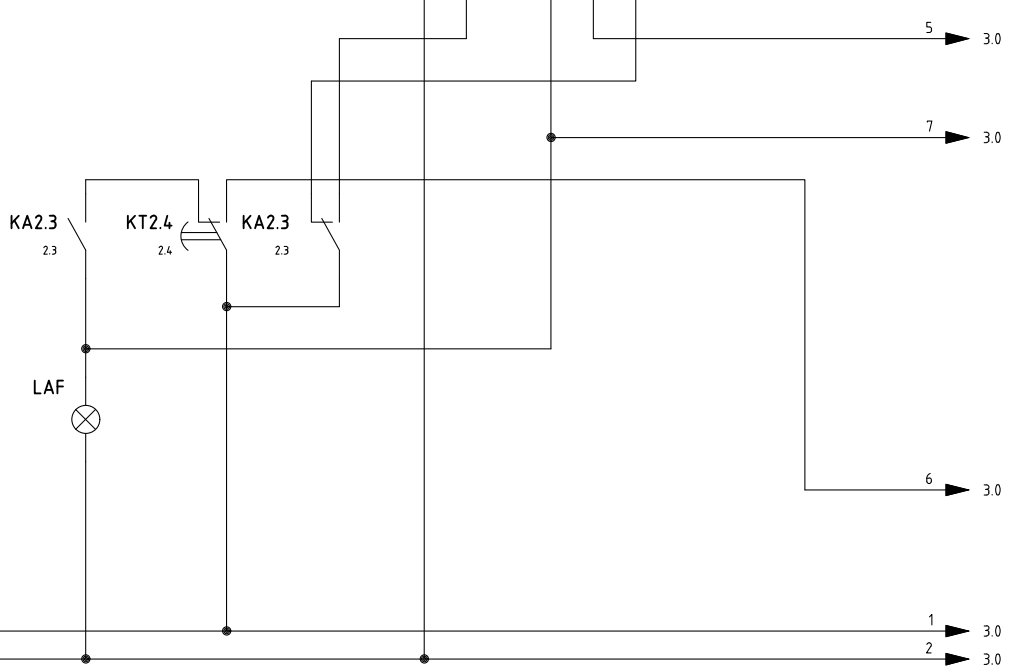
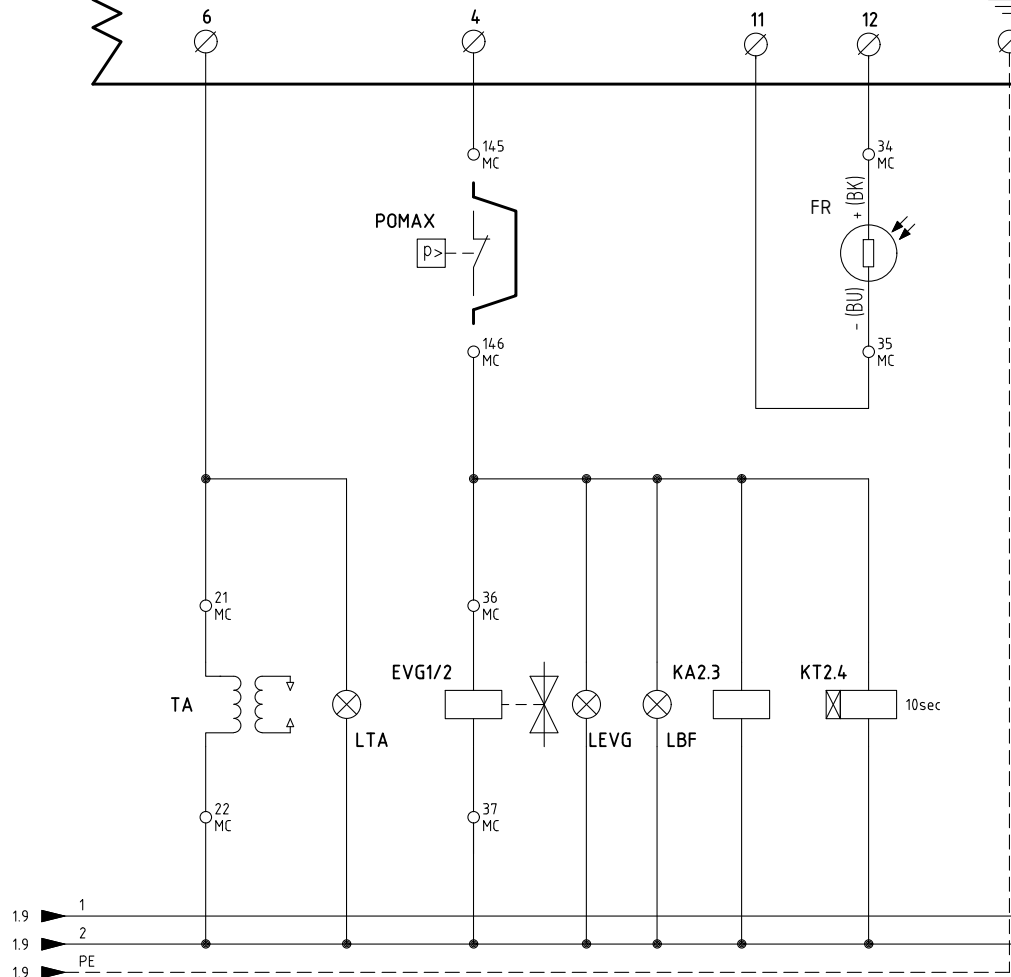
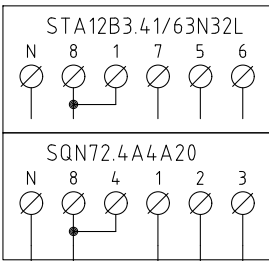
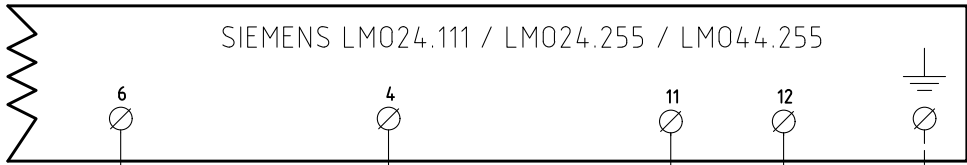

| | | | |
|-----------|------------|-------|--------|
| Data | 26/03/2014 | PREC. | FOGLIO |
| Revisione | 01 | 1 | 2 |
| Dis. N. | 05 - 1022 | SEGUE | TOTALE |
| | | 3 | 6 |

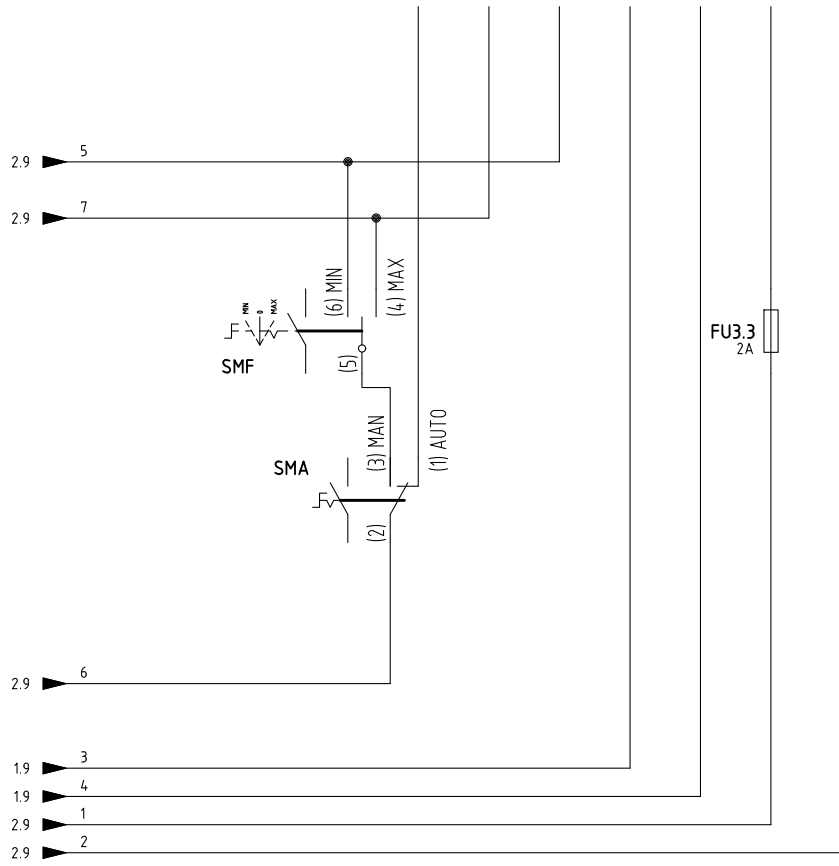
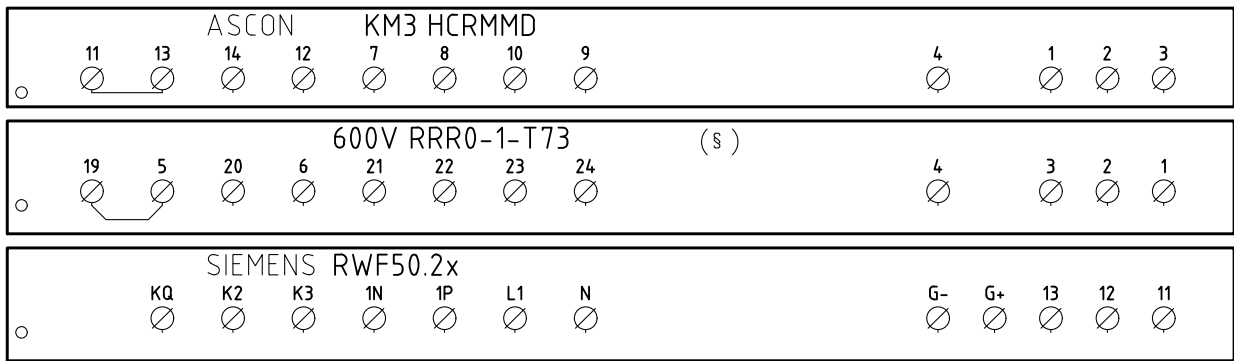

CAVO 7x0,75mmq
7x0,75mmq CABLE

CONN. 7 PINS

(xx)
ATTENZIONE COLLEGAMENTO SONDE CON CONNETTORE 7 POLI
WARNING PROBE CONNECTION WITH 7 PINS CONNECTOR

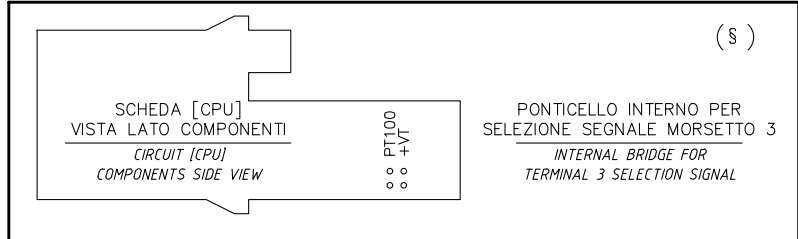

§
VERSIONE (PR) / VERSIONE (MD) CON RWF.. / 600V / KM3
(PR) VERSION / (MD) VERSION WITH RWF.. / 600V / KM3

| | | | |
|-----------|------------|-------|--------|
| Data | 26/03/2014 | PREC. | FOGLIO |
| Revisione | 01 | 2 | 3 |
| Dis. N. | 05 - 1022 | SEQUE | TOTALE |
| | | 4 | 6 |

(xx)
 ATTENZIONE COLLEGAMENTO SONDE CON CONNETTORE 7 POLI
 WARNING PROBE CONNECTION WITH 7 PINS CONNECTOR

KM3 HCRMMD

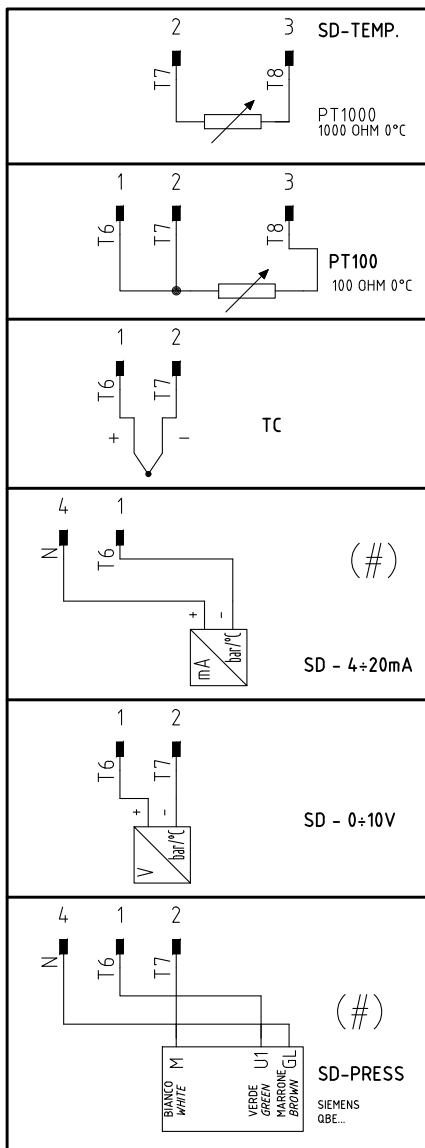

600V RRR0-1-T73

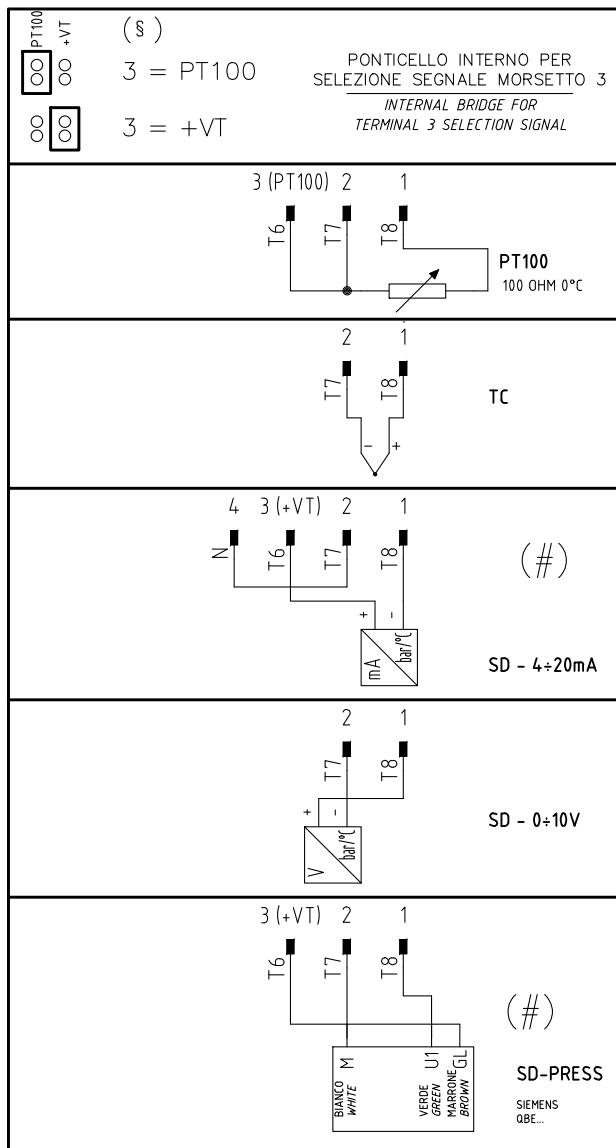

RWF50.2x

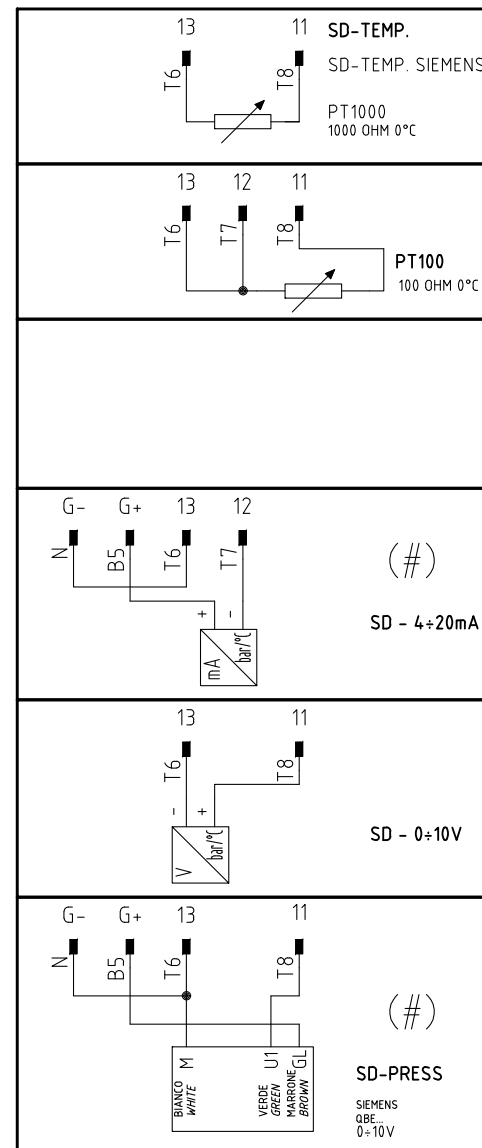

(#)
 COLLEGAMENTO SOLO PER
 TRASDUTTORI PASSIVI
 TRASDUCER PASSIVE
 CONNECTION ONLY

| | | | |
|-----------|------------|-------|--------|
| Data | 26/03/2014 | PREC. | FOGLIO |
| Revisione | 01 | 3 | 4 |
| Dis. N. | 05 - 1022 | SEQUE | TOTALE |
| | | 5 | 6 |

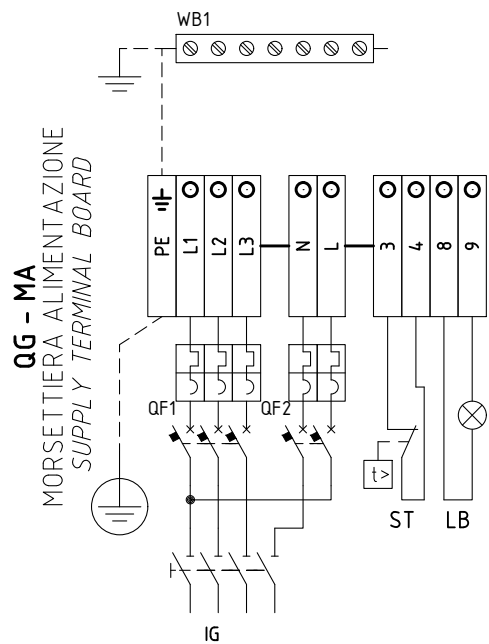

SERVOCOMANDO SERRANDA ARIA
 AIR DAMPER ACTUATOR
 BERGER STA12B3.41/63N32L

ST2 ALTA FIAMMA
 HIGH FLAME
 ST0 SOSTA E ACCENSIONE
 STAND-BY AND IGNITION
 ST1 BASSA FIAMMA
 LOW FLAME

SERVOCOMANDO SERRANDA ARIA (ALTERNATIVO)
 AIR DAMPER ACTUATOR (ALTERNATIVE)
 SIEMENS SQN72.4A4A20

I (ROSSO) ALTA FIAMMA
 I (RED) HIGH FLAME
 II (BLU) SOSTA E ACCENSIONE
 II (BLUE) STAND-BY AND IGNITION
 III (ARANCIO) BASSA FIAMMA
 III (ORANGE) LOW FLAME

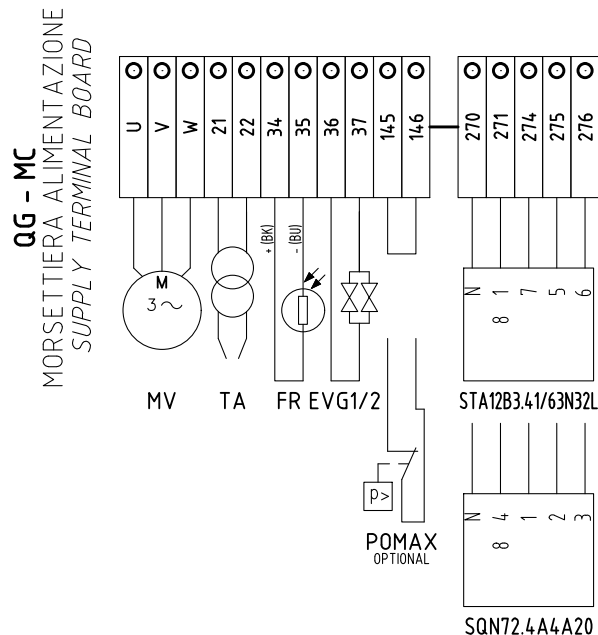

STA12B3.41/63N32L
 SQN72.4A4A20

| | | | |
|-----------|------------|-------|--------|
| Data | 26/03/2014 | PREC. | FOGLIO |
| Revisione | 01 | 4 | 5 |
| Dis. N. | 05 - 1022 | SEGUE | TOTALE |
| | | 6 | 6 |

| Sigla/Item | Foglio/Sheet | Funzione | Function |
|-------------------|--------------|--|---|
| 600V RRR0-1-T73 | 3 | REGOLATORE MODULANTE (ALTERNATIVO) | BURNER MODULATOR (ALTERNATIVE) |
| EVG1/2 | 2 | ELETTROVALVOLE GASOLIO | LIGHT OIL ELECTRO VALVES |
| FR | 2 | FOTORESISTENZA RILEVAZIONE FIAMMA | PHOTORESISTOR FLAME DETECTOR |
| FU1.3 | 1 | FUSIBILE LINEA AUSILIARI | AUXILIARY LINE FUSE |
| FU3.3 | 3 | FUSIBILE | FUSE |
| IG | 1 | INTERRUTTORE GENERALE | MAINS SWITCH |
| IL | 1 | INTERRUTTORE LINEA AUSILIARI | AUXILIARY LINE SWITCH |
| KA2.3 | 2 | RELE" AUSILIARIO | AUXILIARY RELAY |
| KM1.7 | 1 | CONTATTORE MOTORE VENTILATORE | FAN MOTOR CONTACTOR |
| KM3 HCRMMD | 3 | REGOLATORE MODULANTE (ALTERNATIVO) | BURNER MODULATOR (ALTERNATIVE) |
| KT2.4 | 2 | RELE" TEMPORIZZATORE | DELAYED RELAY |
| LAF | 2 | LAMPADA SEGNALAZIONE ALTA FIAMMA BRUCIATORE | BURNER IN HIGH FLAME INDICATOR LIGHT |
| LB | 1 | LAMPADA SEGNALAZIONE BLOCCO FIAMMA | BURNER LOCK-OUT INDICATOR LIGHT |
| LBF | 2 | LAMPADA SEGNALAZIONE BASSA FIAMMA BRUCIATORE | BURNER IN LOW FLAME INDICATOR LIGHT |
| LEVG | 2 | LAMPADA SEGNALAZIONE APERTURA [EVG] | INDICATOR LIGHT FOR OPENING OF ELECTRO-VALVE [EVG] |
| LM0... | 1 | APPARECCHIATURA CONTROLLO FIAMMA | CONTROL BOX |
| LT | 1 | LAMPADA SEGNALAZIONE BLOCCO TERMICO MOTORE VENTILATORE | INDICATOR LIGHT FOR FAN MOTOR OVERLOAD THERMAL CUTOUT |
| LTA | 2 | LAMPADA SEGNALAZIONE TRASFORMATORE DI ACCENSIONE | IGNITION TRANSFORMER INDICATOR LIGHT |
| MV | 1 | MOTORE VENTILATORE | FAN MOTOR |
| POMAX | 2 | PRESSOSTATO DI MASSIMA PRESSIONE OLIO (OPTIONAL) | MAXIMUM OIL PRESSURE SWITCH (OPTIONAL) |
| PS | 1 | PULSANTE SBLOCCO FIAMMA | FLAME UNLOCK BUTTON |
| QF1 | 1 | MAGNETOTERMICO PROTEZIONE ALIMENTAZIONE TRIFASE | THREE-PHASE POWER CIRCUIT BREAKER PROTECTION |
| QF2 | 1 | MAGNETOTERMICO PROTEZIONE LINEA AUSILIARI | AUXILIARY SUPPLY CIRCUIT BREAKER PROTECTION |
| RWF50.2x | 3 | REGOLATORE MODULANTE | BURNER MODULATOR |
| SMA | 3 | SELETTORE MANUALE/AUTOMATICO | MANUAL/AUTOMATIC SWITCH |
| SMF | 3 | SELETTORE MANUALE FUNZIONAMENTO MIN-0-MAX | MIN-0-MAX MANUAL OPERATION SWITCH |
| SQN72.4A4A20 | 2 | SERVOCOMANDO SERRANDA ARIA (ALTERNATIVO) | AIR DAMPER ACTUATOR (ALTERNATIVE) |
| ST | 1 | SERIE TERMOSTATI/PRESSOSTATI | SERIES OF THERMOSTATS OR PRESSURE SWITCHES |
| STA12B3.41/63N32L | 2 | SERVOCOMANDO SERRANDA ARIA | AIR DAMPER ACTUATOR |
| TA | 2 | TRASFORMATORE DI ACCENSIONE | IGNITION TRANSFORMER |
| TV | 1 | TERMICO MOTORE VENTILATORE | FAN MOTOR THERMAL |
| WB1 | 1 | BARRA DI TERRA | EARTH TERMINAL |

| | | | |
|-----------|------------|-------|--------|
| Data | 26/03/2014 | PREC. | FOGLIO |
| Revisione | 01 | 5 | 6 |
| Dis. N. | 05 - 1022 | SEGUE | TOTALE |
| | | / | 6 |

PG70 - PG81

Wiring diagram 07-352 - Progressive Burners - PG70-PG81

Wiring diagram 07-401 - Fully-modulating Burners PG70-PG81

400V 3N a.c.

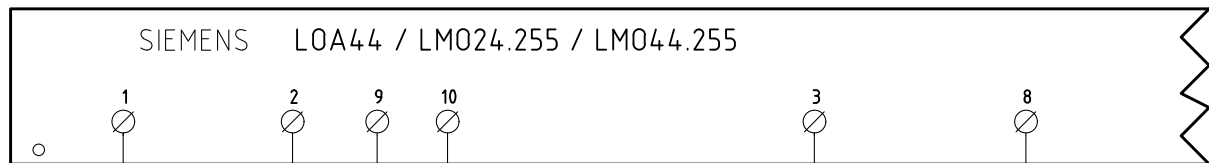
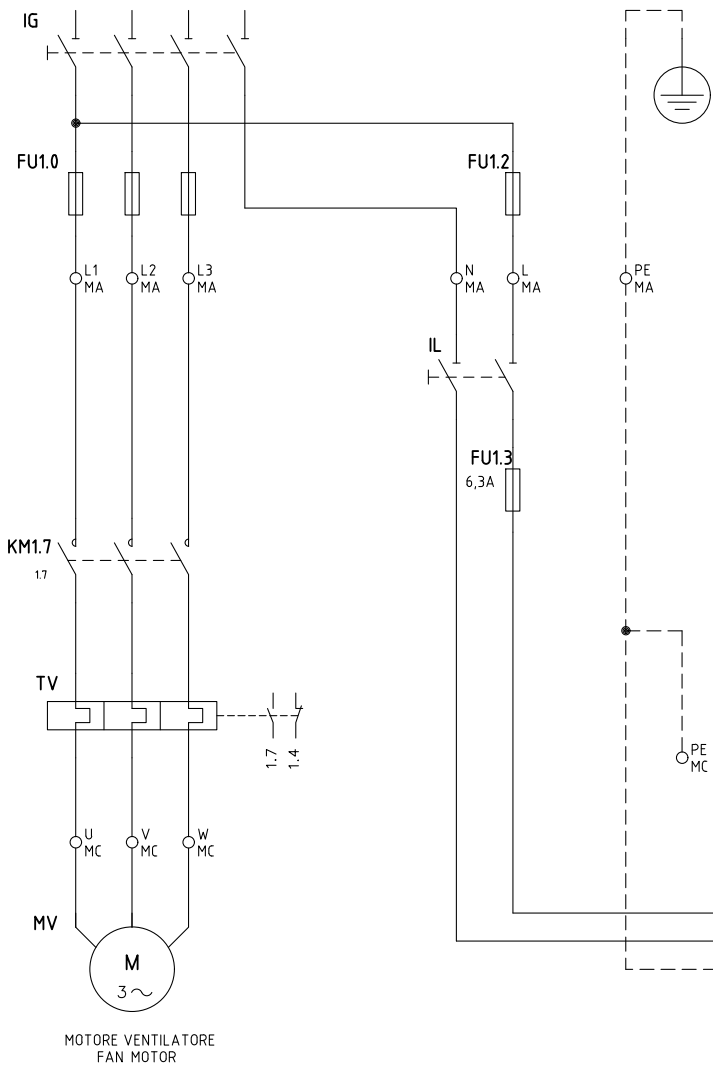

4 MA

3 MA

8 MA

9 MA

- 1 2.0
- 2 2.0
- PE 2.0
- 3 2.0
- 4 2.0

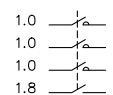

| | | | |
|-----------|------------|-------|--------|
| Data | 11/12/1996 | PREC. | FOGLIO |
| Revisione | 07 | / | 1 |
| Dis. N. | 07 - 0352 | SEGUE | TOTALE |
| | | 2 | 4 |

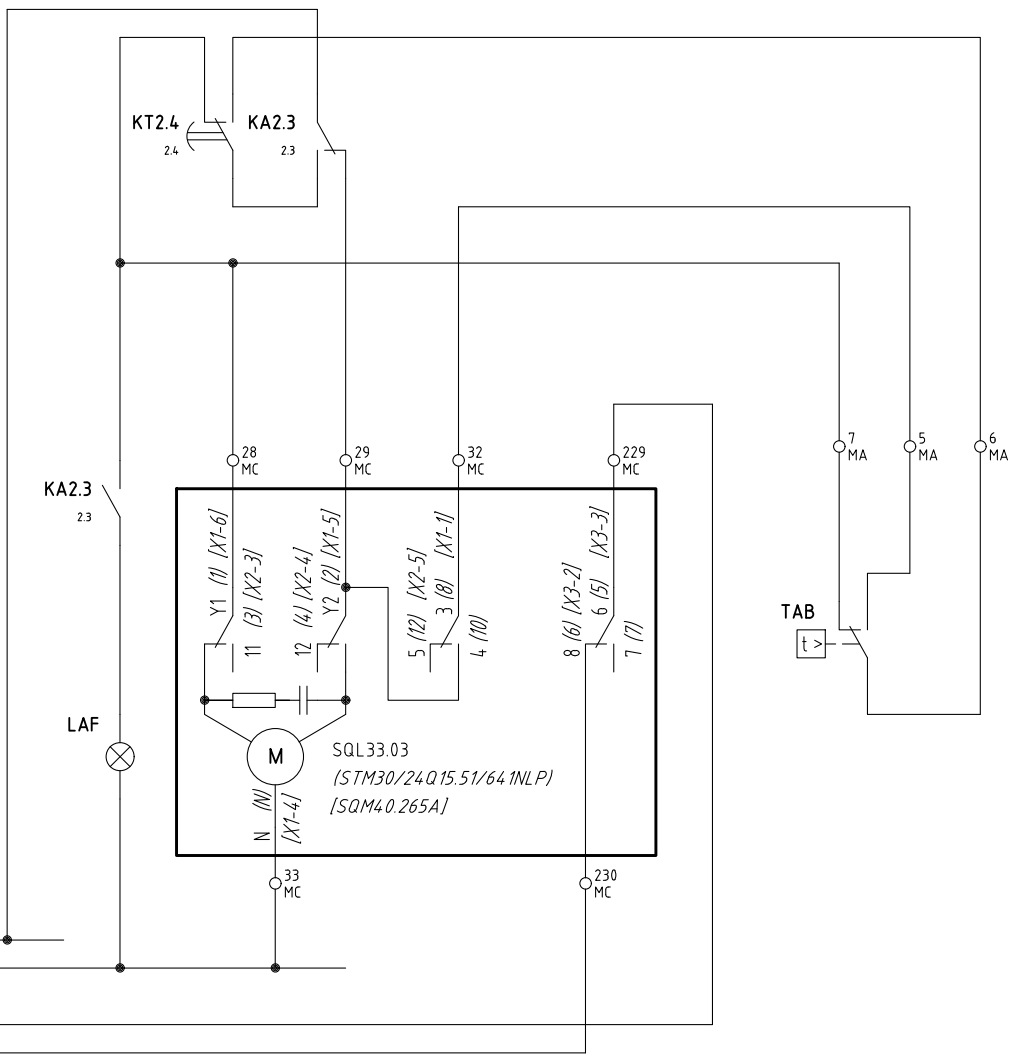
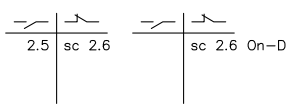
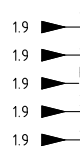
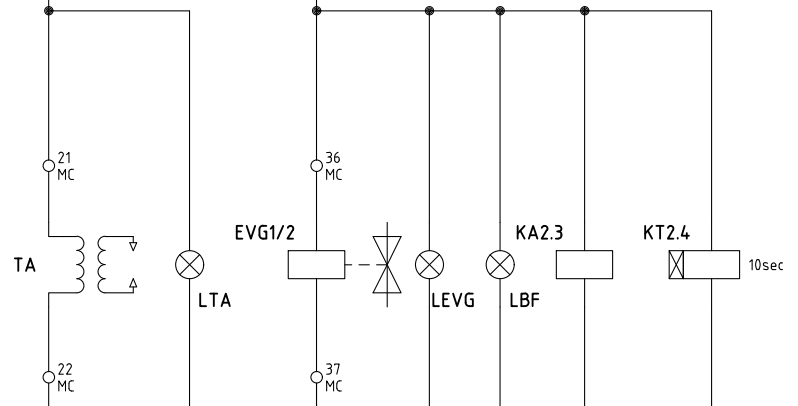
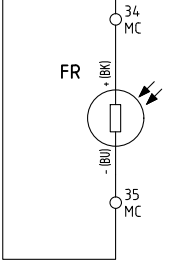
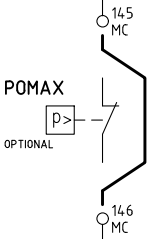
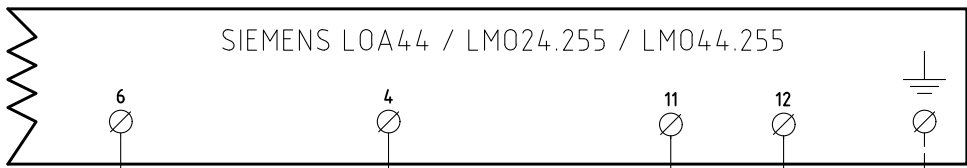

| | | | |
|-----------|------------|-------|--------|
| Data | 11/12/1996 | PREC. | FOGLIO |
| Revisione | 07 | 1 | 2 |
| Dis. N. | 07 - 0352 | SEGUE | TOTALE |
| | | 3 | 4 |

QG - MA
MORSETTIERA ALIMENTAZIONE
SUPPLY TERMINAL BOARD

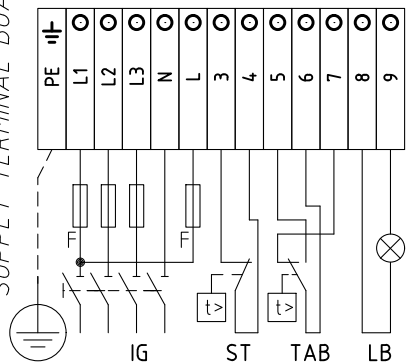

QG - MC
MORSETTIERA ALIMENTAZIONE
SUPPLY TERMINAL BOARD

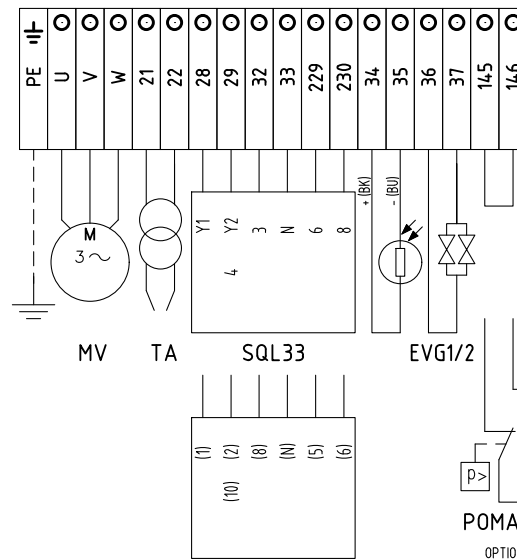

CAMME SERVOCOMANDO
SERVO CONTROL CAMS
SQL33.03

- Y1 ALTA FIAMMA
HIGH FLAME
- Y2 SOSTA E ACCENSIONE
STAND-BY AND IGNITION
- 3 BASSA FIAMMA
LOW FLAME
- 6 CONSENSO ALLA PARTENZA
INPUT TO START

SERVOCOMANDO SERRANDA ARIA (ALTERNATIVO)
AIR DAMPER SERVO CONTROL (ALTERNATIVE)
(STM30/24Q15.51/641NLP)

- I ALTA FIAMMA
HIGH FLAME
- II SOSTA E ACCENSIONE
STAND-BY AND IGNITION
- III BASSA FIAMMA
LOW FLAME
- V CONSENSO ALLA PARTENZA
INPUT TO START

SERVOCOMANDO SERRANDA ARIA (ALTERNATIVO)
AIR DAMPER SERVO CONTROL (ALTERNATIVE)
[SQM40.265A]

- I ALTA FIAMMA
HIGH FLAME
- II SOSTA E ACCENSIONE
STAND-BY AND IGNITION
- III BASSA FIAMMA
LOW FLAME
- VI CONSENSO ALLA PARTENZA
INPUT TO START

(STM30/24Q15.51/643NLP)



[SQM40.265A]

POMAX
OPTIONAL

| | | | |
|-----------|------------|-------|--------|
| Data | 11/12/1996 | PREC. | FOGLIO |
| Revisione | 07 | 2 | 3 |
| Dis. N. | 07 - 0352 | SEGUE | TOTALE |
| | | 4 | 4 |

| SIGLA/ITEM | FOGLIO/SHEET | FUNZIONE | FUNCTION |
|-------------------------------|--------------|--|--|
| [STM30/24Q15.51/64INLP] | 2 | SERVOCOMANDO SERRANDA ARIA (ALTERNATIVO) | AIR DAMPER ACTUATOR (ALTERNATIVE) |
| EVG1/2 | 2 | ELETTROVALVOLE GASOLIO | LIGHT OIL ELECTRO VALVE |
| FR | 2 | FOTORESISTENZA RILEVAZIONE FIAMMA | PHOTORESISTOR FLAME DETECTOR |
| FU1.0 | 1 | FUSIBILI DI LINEA | LINE FUSES |
| FU1.2 | 1 | FUSIBILE DI LINEA | LINE FUSE |
| FU1.3 | 1 | FUSIBILE LINEA AUSILIARI | AUXILIARY LINE FUSE |
| IG | 1 | INTERRUTTORE GENERALE | MAIN DISCONNECTOR |
| IL | 1 | INTERRUTTORE LINEA AUSILIARI | AUXILIARY LINE SWITCH |
| KA2.3 | 2 | RELE' AUSILIARIO | AUXILIARY RELAY |
| KM1.7 | 1 | CONTATTORE MOTORE VENTILATORE | FAN MOTOR CONTACTOR |
| KT2.4 | 2 | RELE' TEMPORIZZATORE | DELAYED RELAY |
| LAF | 2 | LAMPADA SEGNALAZIONE ALTA FIAMMA BRUCIATORE | BURNER IN HIGH FLAME INDICATOR LIGHT |
| LB | 1 | LAMPADA SEGNALAZIONE BLOCCO FIAMMA | BURNER LOCK-OUT INDICATOR LIGHT |
| LBF | 2 | LAMPADA SEGNALAZIONE BASSA FIAMMA BRUCIATORE | BURNER IN LOW FLAME INDICATOR LIGHT |
| LEVG | 2 | LAMPADA SEGNALAZIONE APERTURA EVG | INDICATOR LIGHT FOR OPENING OF ELECTRO-VALVE EVG |
| LOA44 / LM024.255 / LM044.255 | 1 | APPARECCHIATURA CONTROLLO FIAMMA | FLAME MONITOR DEVICE |
| LT | 1 | LAMPADA SEGNALAZIONE BLOCCO TERMICO MOTORE VENTILATORE | INDICATOR LIGHT FOR FAN OVERLOAD TRIPPED |
| LTA | 2 | LAMPADA SEGNALAZIONE TRASFORMATORE DI ACCENSIONE | IGNITION TRANSFORMER INDICATOR LIGHT |
| MV | 1 | MOTORE VENTILATORE | FAN MOTOR |
| POMAX | 2 | PRESSOSTATO DI MASSIMA PRESSIONE OLIO (OPTIONAL) | MAXIMUM OIL PRESSURE SWITCH (OPTIONAL) |
| PS | 1 | PULSANTE SBLOCCO FIAMMA | LOCK-OUT RESET BUTTON |
| SQL33.03 | 2 | SERVOCOMANDO SERRANDA ARIA | AIR DAMPER ACTUATOR |
| ST | 1 | SERIE TERMOSTATI/PRESSOSTATI | SERIES OF THERMOSTATS OR PRESSURE SWITCHES |
| TA | 2 | TRASFORMATORE DI ACCENSIONE | IGNITION TRANSFORMER |
| TAB | 2 | TERMOSTATO/PRESSOSTATO ALTA-BASSA FIAMMA | HIGH-LOW THERMOSTAT/PRESSURE SWITCHES |
| TV | 1 | TERMICO MOTORE VENTILATORE | FAN MOTOR THERMAL |
| [SQM40.265A] | 2 | SERVOCOMANDO SERRANDA ARIA (ALTERNATIVO) | AIR DAMPER ACTUATOR (ALTERNATIVE) |

| | | | |
|-----------|------------|-------|--------|
| Data | 11/12/1996 | PREC. | FOGLIO |
| Revisione | 07 | 3 | 4 |
| Dis. N. | 07 - 0352 | SEGUE | TOTALE |
| | | 1 | 4 |

400V 3N a.c.

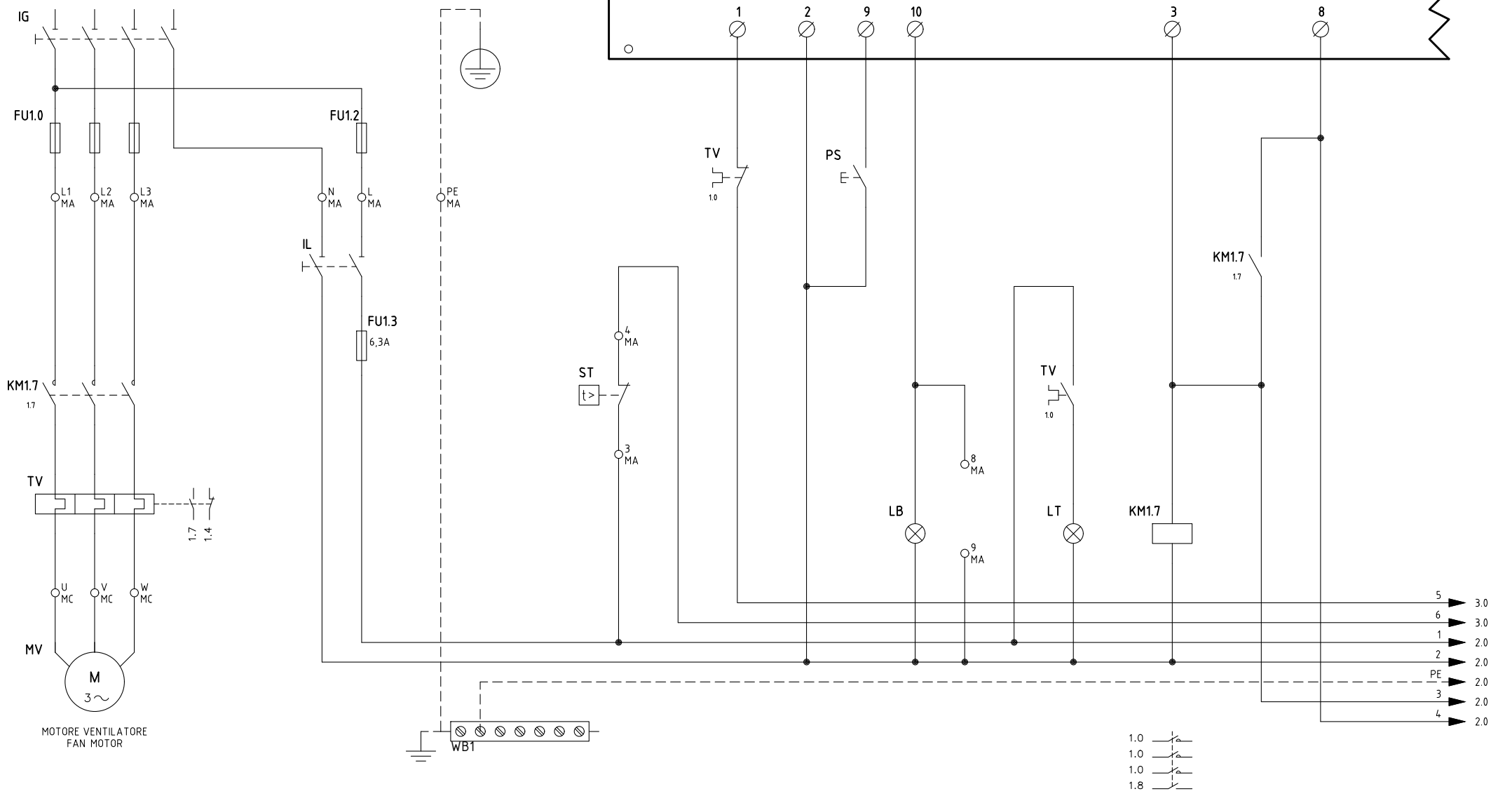

MOTORE VENTILATORE
FAN MOTOR

| | | | |
|-----------|------------|-------|--------|
| Data | 23/02/2000 | PREC. | FOGLIO |
| Revisione | 10 | / | 1 |
| Dis. N. | 07 - 0401 | SEGUE | TOTALE |
| | | 2 | 6 |

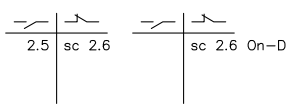
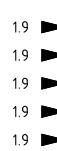
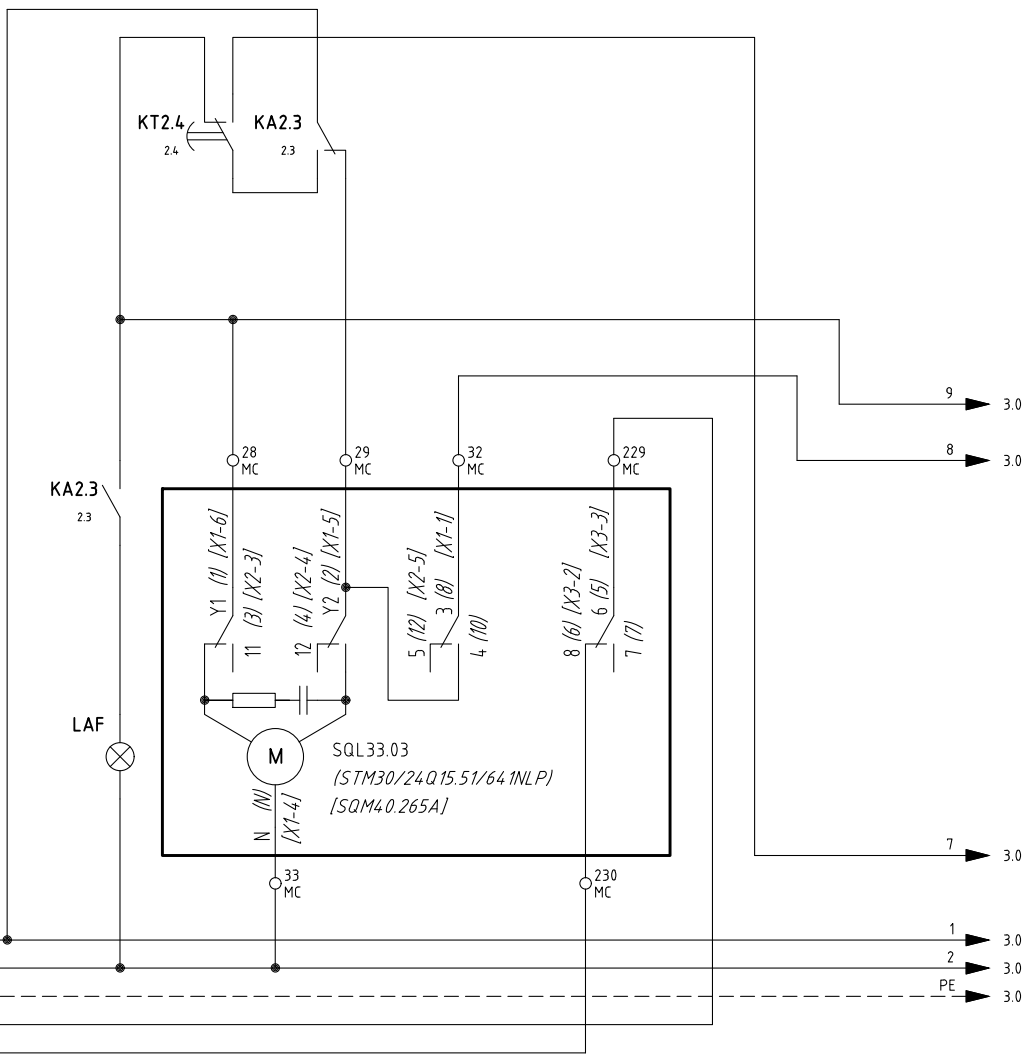
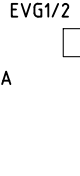
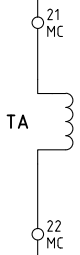
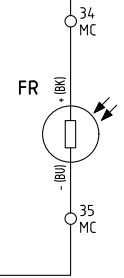
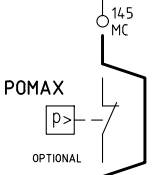
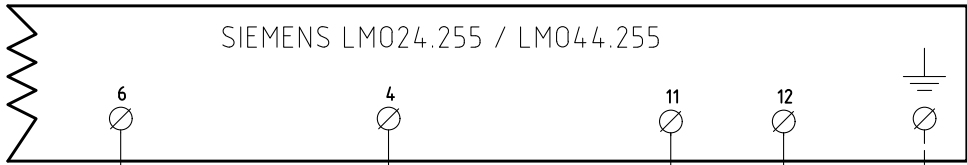

| | | | |
|-----------|------------|-------|--------|
| Data | 23/02/2000 | PREC. | FOGLIO |
| Revisione | 10 | 1 | 2 |
| Dis. N. | 07 - 0401 | SEGUE | TOTALE |
| | | 3 | 6 |

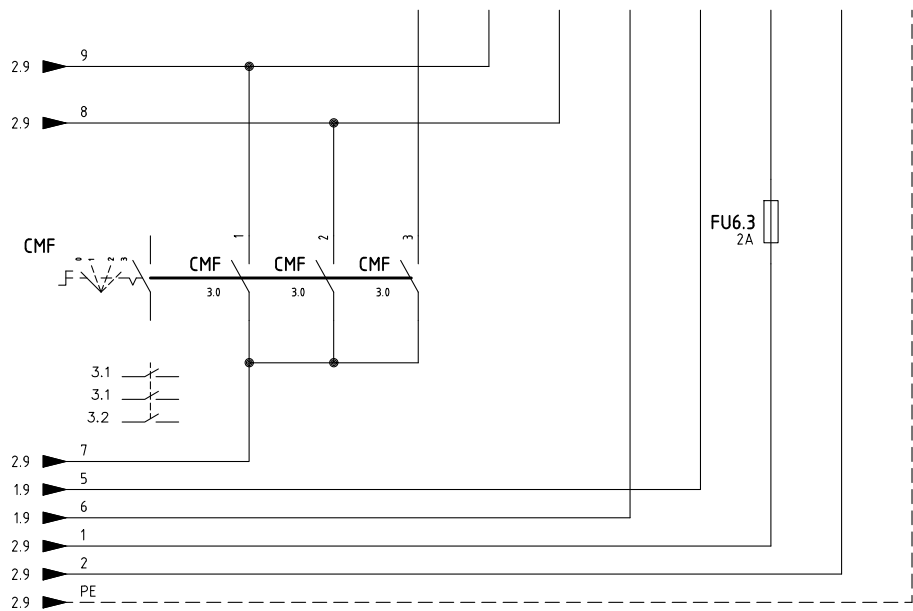
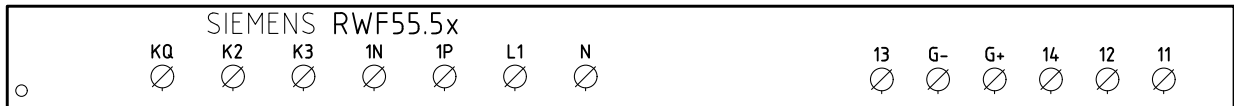
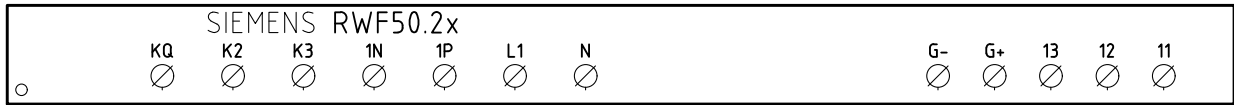
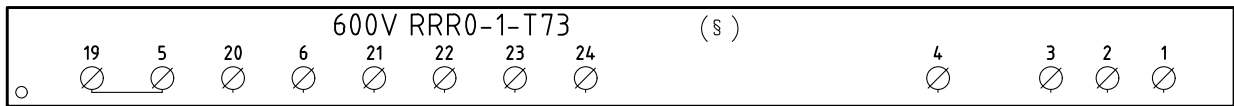
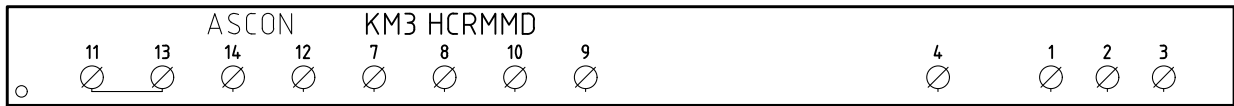

CONN. 7 PINS

- L1 MARRONE / BROWN
- N BLU / BLUE
- B5 ROSSO / RED
- T6 NERO / BLACK
- T7 BIANCO / WHITE
- T8 ARANCIO / ORANGE

CAVO 7x0,75mmq
7x0,75mmq CABLE

(xx)
ATTENZIONE COLLEGAMENTO SONDE CON CONNETTORE 7 POLI
WARNING PROBE CONNECTION WITH 7 PINS CONNECTOR

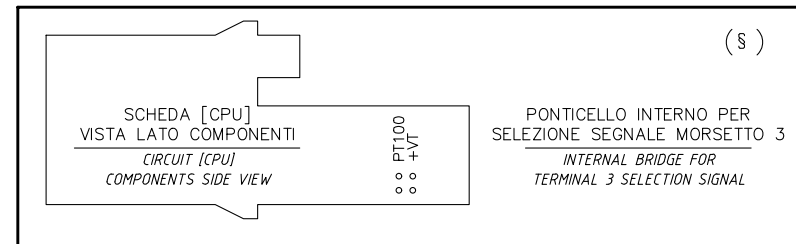

§
VERSIONE (PR) / VERSIONE (MD) CON RWF.. / 600V / KM3
(PR) VERSION / (MD) VERSION WITH RWF.. / 600V / KM3

| | | | |
|-----------|------------|-------|--------|
| Data | 23/02/2000 | PREC. | FOGLIO |
| Revisione | 10 | 2 | 3 |
| Dis. N. | 07 - 0401 | SEQUE | TOTALE |
| | | 4 | 6 |

(xx)

ATTENZIONE COLLEGAMENTO SONDE CON CONNETTORE 7 POLI
 WARNING PROBE CONNECTION WITH 7 PINS CONNECTOR

KM3 HCRMMD

600V RRR0-1-T73

RWF55.5x

RWF50.2x

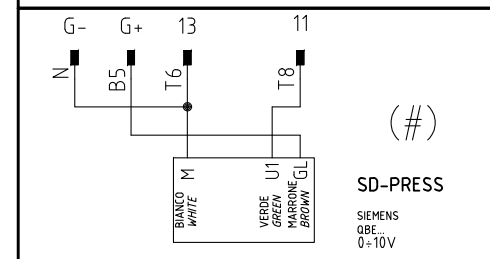
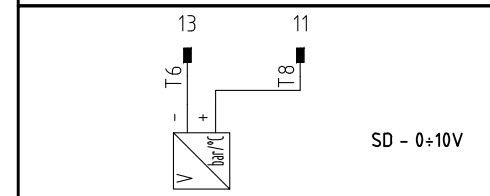
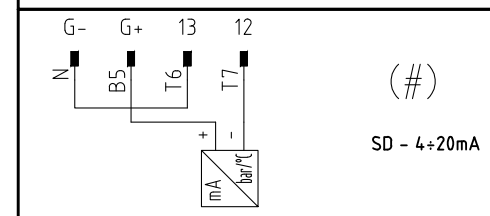
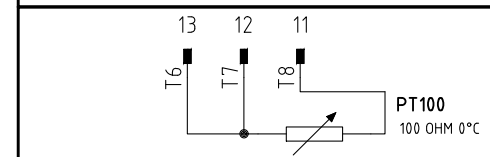
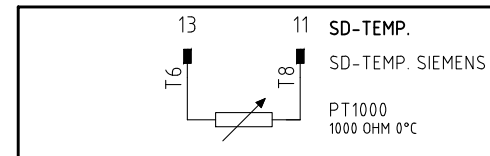
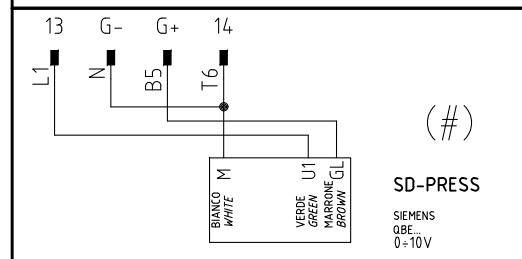
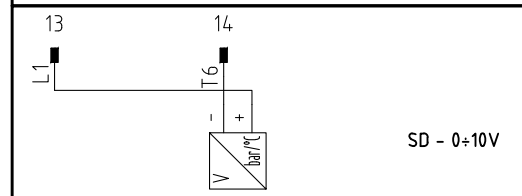
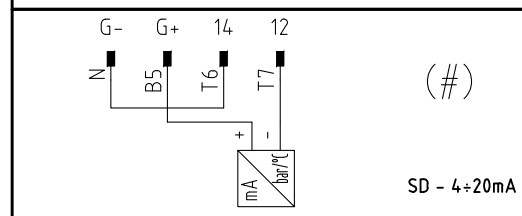
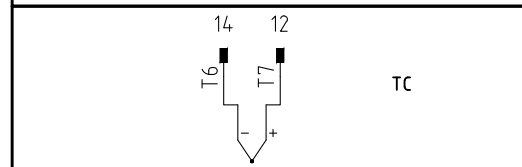
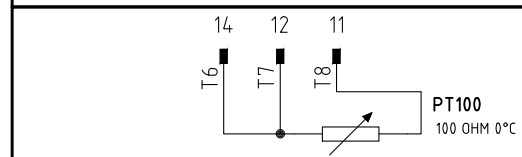
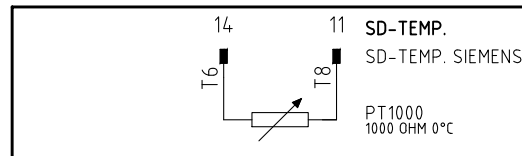
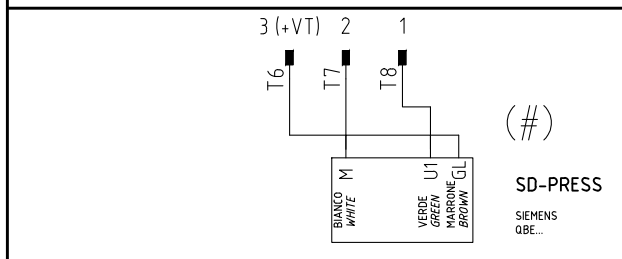
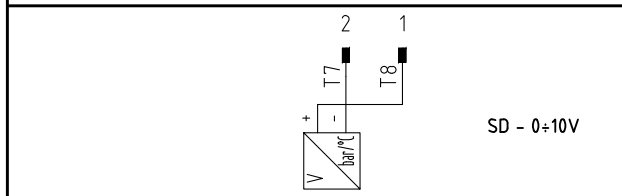
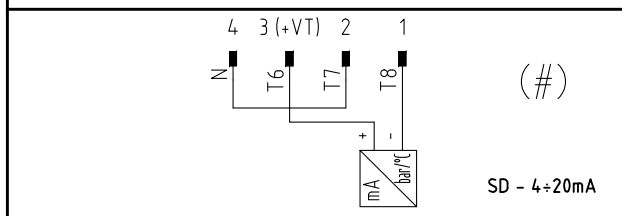
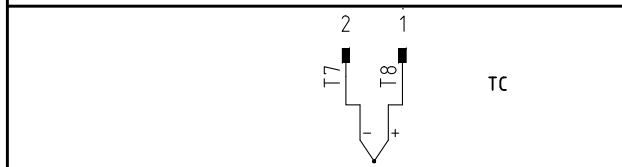
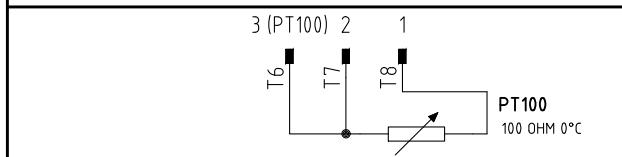
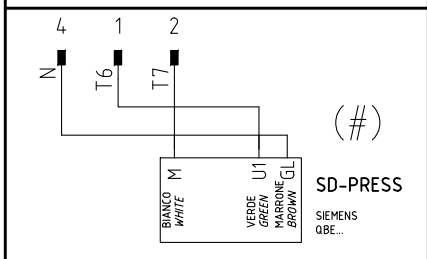
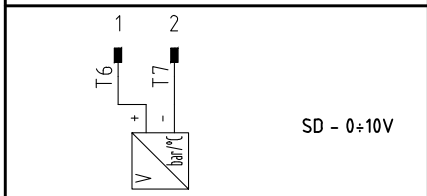
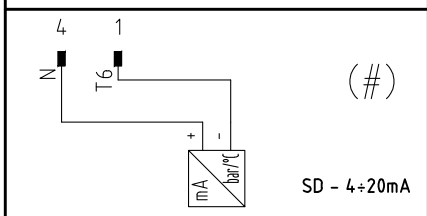
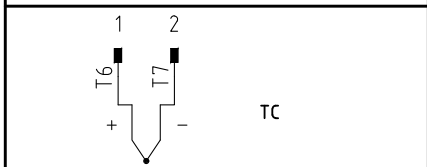
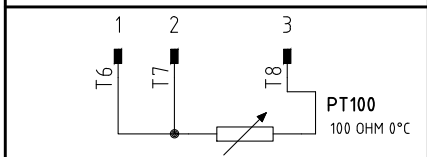
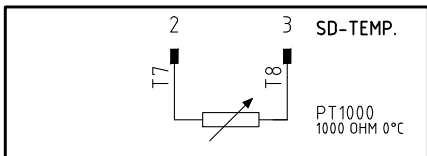

(#)

COLLEGAMENTO SOLO PER
 TRASDUTTORI PASSIVI
 TRASDUCER PASSIVE
 CONNECTION ONLY

| | | | |
|-----------|------------|-------|--------|
| Data | 23/02/2000 | PREC. | FOGLIO |
| Revisione | 10 | 3 | 4 |
| Dis. N. | 07 - 0401 | SEGUE | TOTALE |
| | | 5 | 6 |

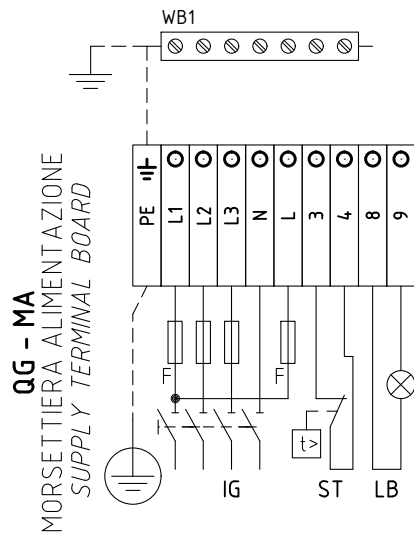

CAMME SERVOCOMANDO

ACTUATOR CAMS

SQL33.03

- Y1 ALTA FIAMMA
HIGH FLAME
- Y2 SOSTA E ACCENSIONE
STAND-BY AND IGNITION
- 3 BASSA FIAMMA
LOW FLAME
- 6 CONSENSO ALLA PARTENZA
INPUT TO START

SERVOCOMANDO SERRANDA ARIA (ALTERNATIVO)

AIR DAMPER ACTUATOR (ALTERNATIVE)

(STM30/24Q15.51/641NLP)

- I ALTA FIAMMA
HIGH FLAME
- II SOSTA E ACCENSIONE
STAND-BY AND IGNITION
- III BASSA FIAMMA
LOW FLAME
- V CONSENSO ALLA PARTENZA
INPUT TO START

SERVOCOMANDO SERRANDA ARIA (ALTERNATIVO)

AIR DAMPER ACTUATOR (ALTERNATIVE)

[SQM40.265A]

- I ALTA FIAMMA
HIGH FLAME
- II SOSTA E ACCENSIONE
STAND-BY AND IGNITION
- III BASSA FIAMMA
LOW FLAME
- VI CONSENSO ALLA PARTENZA
INPUT TO START

QG - MC
MORSETTIERA ALIMENTAZIONE
SUPPLY TERMINAL BOARD

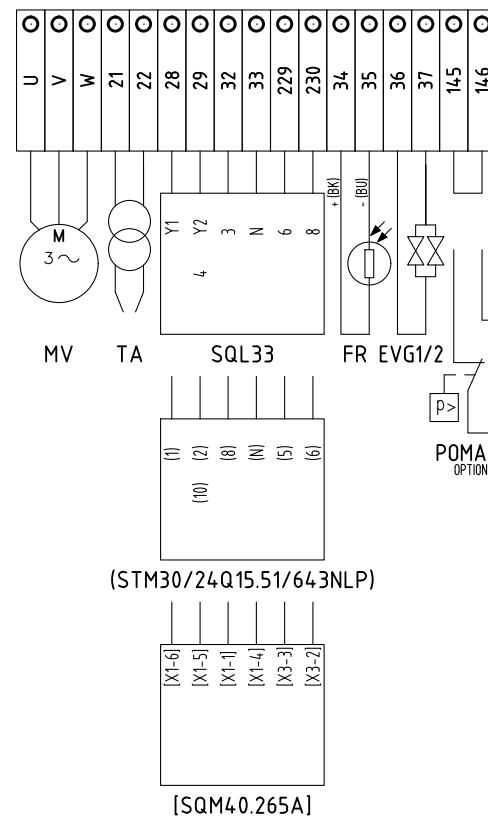

(STM30/24Q15.51/643NLP)

[SQM40.265A]

POMAX
OPTIONAL

| | | | |
|-----------|------------|-------|--------|
| Data | 23/02/2000 | PREC. | FOGLIO |
| Revisione | 10 | 4 | 5 |
| Dis. N. | 07 - 0401 | SEGUE | TOTALE |
| | | 6 | 6 |

| Sigla/Item | Foglio/Sheet | Funzione | Function |
|-------------------------|--------------|---|--|
| 600V RRR0-1-T73 | 3 | REGOLATORE MODULANTE (ALTERNATIVO) | BURNER MODULATOR (ALTERNATIVE) |
| (STM30/24Q15.51/641NLP) | 2 | SERVOCOMANDO SERRANDA ARIA (ALTERNATIVO) | AIR DAMPER ACTUATOR (ALTERNATIVE) |
| CMF | 3 | COMMUT. MANUALE FUNZ. 0)FERMO 1)ALTA FIAMMA 2)BASSA FIAMMA 3)AUTOMATICO | MANUAL SWITCH 0)OFF 1)HIGH FLAME 2)LOW FLAME 3)AUTOMATIC |
| EVG1/2 | 2 | ELETTROVALVOLE GASOLIO | LIGHT OIL ELECTRO VALVES |
| FR | 2 | FOTORESISTENZA RILEVAZIONE FIAMMA | PHOTORESISTOR FLAME DETECTOR |
| FU1.0 | 1 | FUSIBILI DI LINEA | LINE FUSES |
| FU1.2 | 1 | FUSIBILE DI LINEA | LINE FUSE |
| FU1.3 | 1 | FUSIBILE LINEA AUSILIARI | AUXILIARY LINE FUSE |
| FU6.3 | 3 | FUSIBILE | FUSE |
| IG | 1 | INTERRUTTORE GENERALE | MAINS SWITCH |
| IL | 1 | INTERRUTTORE LINEA AUSILIARI | AUXILIARY LINE SWITCH |
| KA2.3 | 2 | RELE" AUSILIARIO | AUXILIARY RELAY |
| KM1.7 | 1 | CONTATTORE MOTORE VENTILATORE | FAN MOTOR CONTACTOR |
| KM3 HCRMMD | 3 | REGOLATORE MODULANTE (ALTERNATIVO) | BURNER MODULATOR (ALTERNATIVE) |
| KT2.4 | 2 | RELE" TEMPORIZZATORE | DELAYED RELAY |
| LAF | 2 | LAMPADA SEGNALAZIONE ALTA FIAMMA BRUCIATORE | BURNER IN HIGH FLAME INDICATOR LIGHT |
| LB | 1 | LAMPADA SEGNALAZIONE BLOCCO FIAMMA | BURNER LOCK-OUT INDICATOR LIGHT |
| LBF | 2 | LAMPADA SEGNALAZIONE BASSA FIAMMA BRUCIATORE | BURNER IN LOW FLAME INDICATOR LIGHT |
| LEVG | 2 | LAMPADA SEGNALAZIONE APERTURA [EVG] | INDICATOR LIGHT FOR OPENING OF ELECTRO-VALVE [EVG] |
| LM024.255 / LM044.255 | 1 | APPARECCHIATURA CONTROLLO FIAMMA | CONTROL BOX |
| LT | 1 | LAMPADA SEGNALAZIONE BLOCCO TERMICO MOTORE VENTILATORE | INDICATOR LIGHT FOR FAN MOTOR OVERLOAD THERMAL CUTOUT |
| LTA | 2 | LAMPADA SEGNALAZIONE TRASFORMATORE DI ACCENSIONE | IGNITION TRANSFORMER INDICATOR LIGHT |
| MV | 1 | MOTORE VENTILATORE | FAN MOTOR |
| POMAX | 2 | PRESSOSTATO DI MASSIMA PRESSIONE OLIO (OPTIONAL) | MAXIMUM OIL PRESSURE SWITCH (OPTIONAL) |
| PS | 1 | PULSANTE SBLOCCO FIAMMA | FLAME UNLOCK BUTTON |
| PT100 | 4 | SONDA DI TEMPERATURA | TEMPERATURE PROBE |
| RWF50.2x | 3 | REGOLATORE MODULANTE | BURNER MODULATOR |
| RWF55.5x | 3 | REGOLATORE MODULANTE (ALTERNATIVO) | BURNER MODULATOR (ALTERNATIVE) |
| SD-PRESS | 4 | SONDA DI PRESSIONE | PRESSURE PROBE |
| SD-TEMP. | 4 | SONDA DI TEMPERATURA | TEMPERATURE PROBE |
| SD - 0÷10V | 4 | TRASDUTTORE USCITA IN TENSIONE | TRANSDUCER VOLTAGE OUTPUT |
| SD - 4÷20mA | 4 | TRASDUTTORE USCITA IN CORRENTE | TRANSDUCER CURRENT OUTPUT |
| SQL33.03 | 2 | SERVOCOMANDO SERRANDA ARIA | AIR DAMPER ACTUATOR |
| ST | 1 | SERIE TERMOSTATI/PRESSOSTATI | SERIES OF THERMOSTATS OR PRESSURE SWITCHES |
| TA | 2 | TRASFORMATORE DI ACCENSIONE | IGNITION TRANSFORMER |
| TC | 4 | TERMOCOPPIA | THERMOCOUPLE |
| TV | 1 | TERMICO MOTORE VENTILATORE | FAN MOTOR THERMAL |
| WB1 | 1 | BARRA DI TERRA | EARTH TERMINAL |
| [SQM40.265A] | 2 | SERVOCOMANDO SERRANDA ARIA (ALTERNATIVO) | AIR DAMPER ACTUATOR (ALTERNATIVE) |

| | | | |
|-----------|------------|-------|--------|
| Data | 23/02/2000 | PREC. | FOGLIO |
| Revisione | 10 | 5 | 6 |
| Dis. N. | 07 - 0401 | SEGUE | TOTALE |
| | | / | 6 |

APPENDIX

SIEMENS OIL BURNERS AUTOMATIC CONTROLLER LOA24

Use

LOA... safety devices are intended for use solely with QRB... photoresistors, for lighting and controlling low capacity forced air light oil burners with max. capacity 30 kg/h in accordance with standard DIN 4787.

The One or two flames are lit through electrical connections with or without post-ignition.

To replace LAI... AND LAB.. WITH LOA...

LOA... models can be used as replacement for LAI... and LAB.. controllers by means of the adapter KF8819 and without the need to change the electrical wiring. Because the LOA is smaller in dimensions, when it is used with the adapter the external dimensions are almost identical, which means that there is no need to move the reset button.

Performance

The controllers just need plugging in, so they can be mounted in almost any position: on the burner, on the electrical panel or on the control panel. The casing is made of robust heat-resistant plastic and contains:

- the thermic programmer operating a multiple switch control system with ambient temperature compensator
- flame signal amplifier with flame relay
- warning light indicating lockout and associated sealed reset button.

The plug-in socket, also made of robust heat-resistant plastic, contains the 12 terminals and also:

- 3 neutral terminals, ready wired up to terminal 2
- 4 earth terminals for earthing the burner
- 2 supplementary terminals numbered "31" and "32".

The socket has two openings at the bottom for the leads; 5 others with threaded connection for cable holders PG11 or 3/4UNP for non-metallic sleeves are located on a mobile stuffing box, one on either side and 3 on the front.

There are two flexible metal tongues on the sides of the socket for mounting.

To dismantle it only requires gentle pressure with a screw driver in the slot of the mounting guide. The base dimensions of the socket are exactly the same as for types LAB/LAI and there is no difference in the diameter of the reset button, the two mounting screws and the flange of the burner earth.

Safety at low voltage levels

Safety devices against any reduction in the mains voltage operate on a special electronic circuit which, in the event of the power supply falling below 165V~, stops the burner switching on without releasing the fuel and locks out the apparatus.

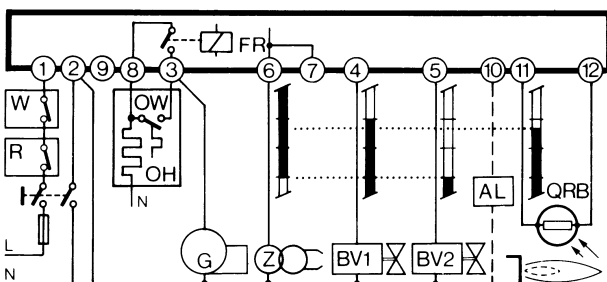

Wiring diagram of the program

To ensure correct wiring it is essential to observe local standards and follow the instructions of the burner manufacturer with regard to assembly and start-up.

Program's legend:

- Controller output signals
- ▤ Required input signals

- A' Burner start up with light oil pre-heater OH
- A Burner start-up without light oil pre-heater
- B Flame lit
- C Normal operation
- D Normal stop through R
- tw Oil pre-heating time until operational all clear given through contact OW

- t1 Pre-purge time
- t3 Pre-ignition time
- t2 Safety time
- t3n Post-ignition time
- t4 Interval between the flame lighting and energising of solenoid 2a at terminal 5

Internal layout

- AL Optical alarm
- BV. Fuel valve
- EK Reset button
- FR Flame relay
- fr Flame relay contacts
- FS Flame alight signal
- G Burner motor
- K Flame relay anchor to delay the tzi command in the event of a premature flame signal or endorse it where the signal is correct.
- OH light oil pre-heater
- OW Operational all-clear contact
- QRB Photo-resistant cell (flame detector)
- R Thermostat or pressure switch
- TZ Thermo-electric programmer (bimetal system)
- tz.. TZ contacts
- V Flame signal amplifier
- W Safety thermostat or pressure switch
- Z Ignition transformer

The above are safety devices!

To tamper with them in any way may have unforeseeable consequences!

Do not open them!

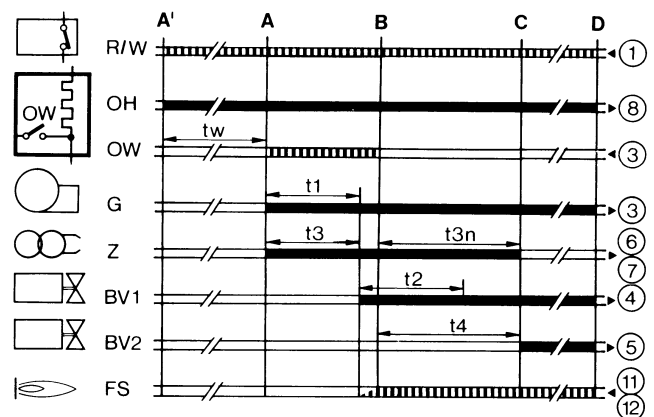

Technical characteristics

| | |
|---------------------|---|
| Voltage | 220V -15%..240V+10% or 100V -15%...110V+10% |
| Frequency | 50...60Hz +/- 6% |
| External fuse | max.10A slow action |
| Contact flow: | |
| - terminal 1 | 5A |
| - terminal 3 | 5A (incl.capacity absorbed by motor and pre-heater) |
| Terminal flow: | |
| terminals 4, 5 &10 | 1A |
| terminals 6&7 | 2A |
| terminal 8 | 5A |
| Absorbed cap | 3VA |
| Protection | IP40 |
| Permitted temp: | |
| operational | -20...+60°C |
| transport & storage | -50...+60°C |
| Emplacement | any |

Mass (weight)

controller 180g, socket 50g,
AGK accessories 12 g.

Commands in the event of operational interference

Stray light/premature ignition

During pre-purge and/or pre-ignition there should be no flamesignal. If there is a flame signal, eg from premature ignition due to a faulty solenoid, external light, short circuit in the photoresisto or wiring, malfunction in the flame signal amplifier, etc., at the end of pre-purge and safety time the controller locks out the burner and stops the fuel flow even during safety time.

Absence of flame

If there is no flame at the end of safety time the controller locks out immediately.

Absence of flame during operation

If there is no flame during operation the controller cuts off the supply of fuel and automatically initiates a fresh start-up programme: at the end of t4 the start-up programme ends.

Whenever there is a safety stop, terminals 3-8 and 11 are de-energised in less than 1 second; at the same time a remote lockout signal is transmitted through terminal 10. The controller can be reset after c. 50 seconds.

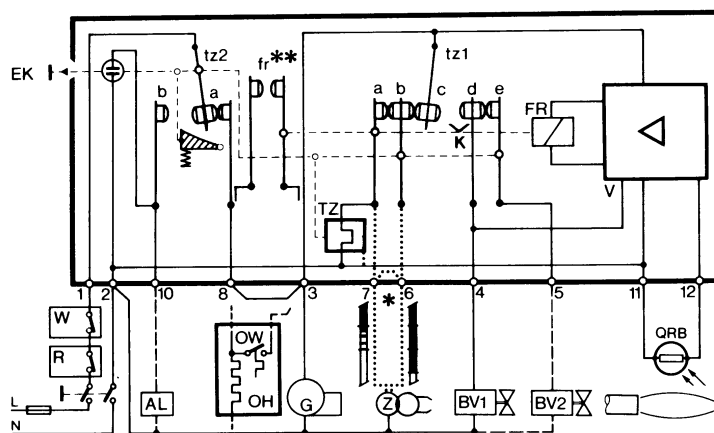

SIEMENS OIL BURNERS AUTOMATIC CONTROLLER SIEMENS LMO14 - LMO24 - LMO44

The LMO... burner controls are designed for the start-up and supervision of single- or 2-stage forced draught oil burners in intermittent operation. Yellow-burning flames are supervised with photoresistive detectors QRB..., blue-burning flames with blue-flame detectors QRC...

In terms of housing dimensions, electrical connections and flame detectors, the LMO... are identical to the LOA... oil burner controls.

Preconditions for startup

- Burner control is reset
- All contacts in the line are closed
- No undervoltage
- Flame detector is darkened, no extraneous light

Undervoltage

- Safety shut-down in the operating position takes place should the mains voltage drop below about AC 165 V
- Restart is initiated when the mains voltage exceeds about AC 175 V

Time supervision oil pre-heater

If the oil pre-heater's release contact does not close within 10 minutes, the burner control will initiate lock-out.

Controlled intermittent operation

After no more than 24 hours of continuous operation, the burner control will initiate an automatic safety shut-down followed by a restart.

Control sequence in the event of fault

If lock-out occurs, the outputs for the fuel valves and the ignition will immediately be deactivated (< 1 second).

| Cause | Response |
|---|----------|
| After a mains failure | Restart |
| After voltage has fallen below the undervoltage threshold | Restart |

| | |
|--|--|
| In the event of a premature, faulty flame signal during «t1» | Lock-out at the end of «t1» |
| In the event of a premature, faulty flame signal during «tw» | Prevention of start-up, lock-out after no more than 40 seconds |
| If the burner does not ignite during «TSA» | Lock-out at the end of TSA |
| In the event the flame is lost during operation | Max. 3 repetitions, followed by lock-out |
| Oil pre-heater's release contact does not close within 10 min. | Lock-out |

Lock-out

In the event of lock-out, the LMO... remains locked (lock-out cannot be changed), and the red signal lamp will light up. This status is also maintained in the case of a mains failure.

Resetting the burner

Whenever lock-out occurs, the burner control can immediately be reset. To do this, keep control the lock-out reset button depressed for about 1 second (< 3 seconds).

Ignition program with LMO24.113A2

If the flame is lost during «TSA», the burner will be reignited, but not later than at the end of «TSAmáx.». This means that several ignition attempts can be made during TSA (refer to «Program sequence»).

Limitation of repetitions

If the flame is lost during operation, a maximum of 3 repetitions can be made. If the flame is lost for the 4th time during operation, the burner will initiate lock-out. The repetition count is restarted each time controlled switching on by «R-W-SB» takes place.

Operation

Lock-out reset button «EK...» is the key operating element for resetting the burner control and for activating / deactivating the diagnostic functions.



 The multicolour «LED» is the key indicating element for both visual diagnosis and interface diagnosis.

- s Red
- l Yellow
- o Green

| Colour code table | | |
|--|--------------|-------------------|
| Status | Colour code | Colour |
| Oil pre-heater heats, waiting time «tw» | llllllllll | Yellow |
| Ignition phase, ignition controlled | lmlmlmlml | Yellow-off |
| Operation, flame o.k. | oooooooo | Green |
| Operation, flame not o.k. | omomomomo | Green-off |
| Undervoltage | lslslslsl | Yellow-red |
| Fault, alarm | ssssssssss | Red |
| Output of fault code (refer to Fault code table) | smsmsmsmsm | Red-off |
| Extraneous light prior to burner start-up | ososososo | Green-red |
| Interface diagnosis | ssssssssssss | Red flicker light |

Key

- m Off
- l Yellow
- o Green
- s Red

Diagnosis of cause of fault

After lock-out, the red fault signal lamp remains steady on. In that condition, the visual diagnosis of the cause of fault according to the error code table can be activated by pressing the lock-out reset button for more than 3 seconds.

| Error code table | |
|------------------|--|
| Blink code | Possible cause |
| 2 blinks ** | No establishment of flame at the end of TSA <ul style="list-style-type: none"> ● Faulty or soiled fuel valves ● Faulty or soiled flame detector ● Poor adjustment of burner, no fuel ● Faulty ignition |
| 3 blinks *** | Free |
| 4 blinks **** | Extraneous light on burner startup |
| 5 blinks ***** | Free |
| 6 blinks **** | Free |
| 7 blinks ***** | Too many losses of flme during operation (limitattion og the number of repetitions) <ul style="list-style-type: none"> ● Faulty or soiled fuel valves ● Faulty or soiled flame detector ● Poor adjustment of burner |
| 8 blinks ***** | Time supervision oil pre-heater |
| 9 blinks ***** | Free |
| 10 blinks ***** | Wiring error or internal error, output contacts |

During the time the cause of fault is diagnosed, the control outputs are deactivated.

- Burner remains shut down
- Fault status signal «AL» at terminal 10 is activated

The diagnosis of the cause of fault is quit and the burner switched on again by resetting the burner control.

Press lock-out reset button for about 1 second (< 3 seconds).

Connection diagram and internal diagram

LMO14

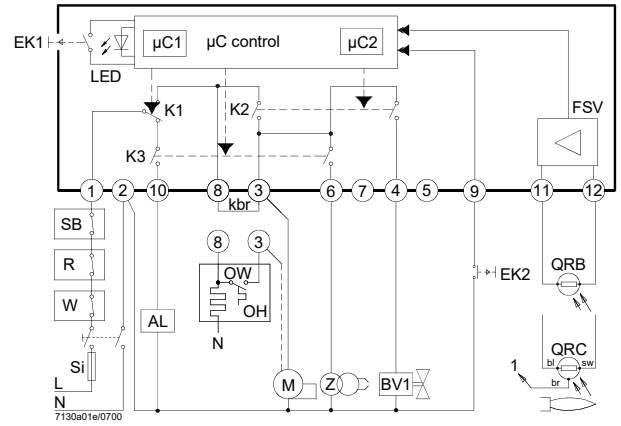

LMO24 - LMO44

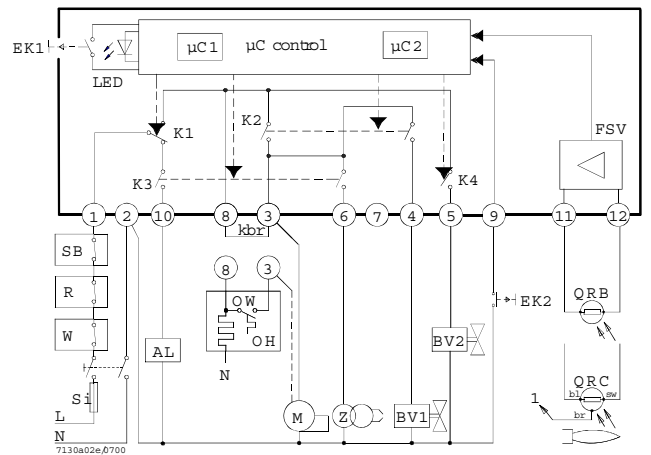

Control sequence

LMO14

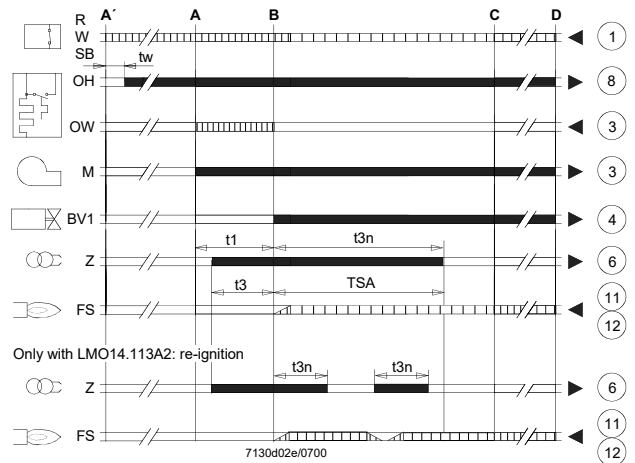

LMO24 - LMO44

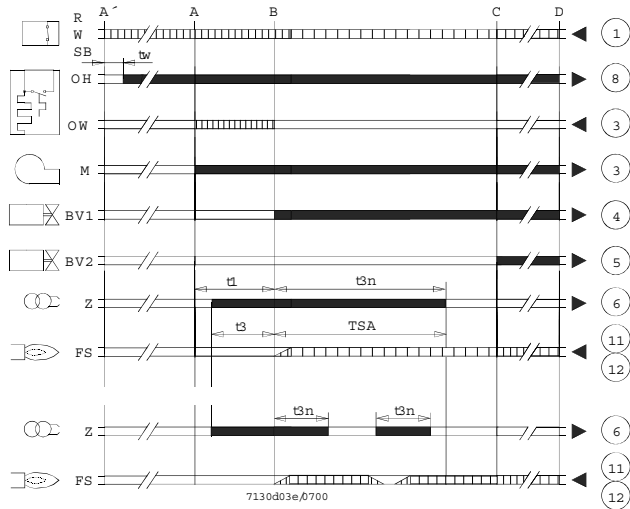

Key

- AL Alarm device
- kbr... Cable link (required only when no oil pre-heater is used)
- BV... Fuel valve
- EK1 Lock-out reset button
- EK2 Remote lock-out reset button
- FS Flame signal
- FSV Flame signal amplifier
- K... Contacts of control relay
- LED 3-colour signal lamps
- M Burner motor
- OW Release contact of oil pre-heater
- t1 Pre-purge time
- t3 Pre-ignition time
- t3n Post-ignition time
- A' Beginning of start-up sequence with burners using an oil pre-heater
- A Beginning of start-up sequence with burners using no oil pre-heater
- Controller output signals
- Required input signals
- OH Oil pre-heater
- QRB Photoresistive detector
- QRC Blue-flame detector
- bl = blue
- br = brown
- sw = black
- R Control thermostat or pressurestat
- SB Safety limit thermostat
- Si External primary fuse
- W Limit thermostat or pressure switch
- Z Ignition transformer
- t4 Interval from flame signal to release «BV2»
- TSA Ignition safety time
- tw Waiting time for oil pre-heating
- B Time of flame establishment
- C Operating position
- D Controlled shut-down by «R»
- μC1 Microcontroller 1
- μC2 Microcontroller 2

General unit data

| | |
|--------------------------------|--|
| Mains voltage | AC 230 V +10 % / -15 % AC 120 V +10 % / -15 % |
| Mains frequency | 50...60 Hz ±6 % |
| External primary fuse (Si) | 6.3A (slow) |
| Power consumption | 12 VA |
| Mounting orientation | optional |
| Weight | approx. 200 g |
| Degree of protection | IP40 (to be ensured through mounting) |
| Perm. cable lengths | max. 3m at line capacitance of 100 pF/m |
| Detector cable laid separately | 10 m |
| Remote reset laid separately | 20m |

| | LMO14 | LMO24 | LMO44 |
|-----------------------|-------|-------|-------|
| Terminal 1 | 5 A | 5 A | 5 A |
| Terminals 3 and 8 | 3 A | 5 A | 5 A |
| Terminals 4, 5 and 10 | 1 A | 1 A | 1 A |
| Terminals 6 | 1 A | 1 A | 2 A |

Flame supervision with QRB and QRC

| | QRB | QRC |
|--|--------|--------|
| Min. detector current required (with flame) | 45 μA | 70 μA |
| Min detector current permitted (without flame) | 5.5 μA | 5.5 μA |
| Max. possible with flame (typically) | 100 μA | 100 μA |

Measurement circuit for detector current

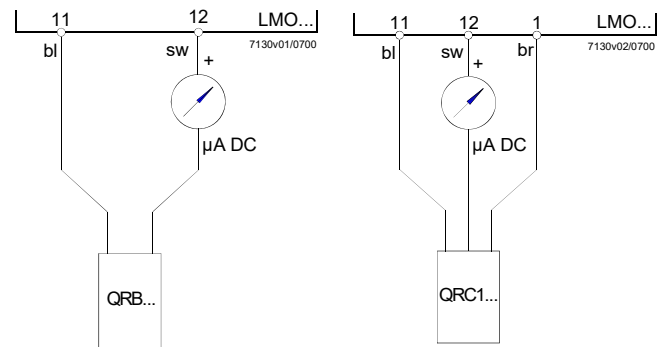

Key

- μA DC DC microammeter with an internal resistance of 5 kΩ max.
- bl Blue
- sw Black
- br Brown



C.I.B. UNIGAS S.p.A.
Via L.Galvani, 9 - 35011 Campodarsego (PD) - ITALY
Tel. +39 049 9200944 - Fax +39 049 9200945/9201269
web site: www.cibunigas.it - e-mail: cibunigas@cibunigas.it

Note: specifications and data subject to change. Errors and omissions excepted.

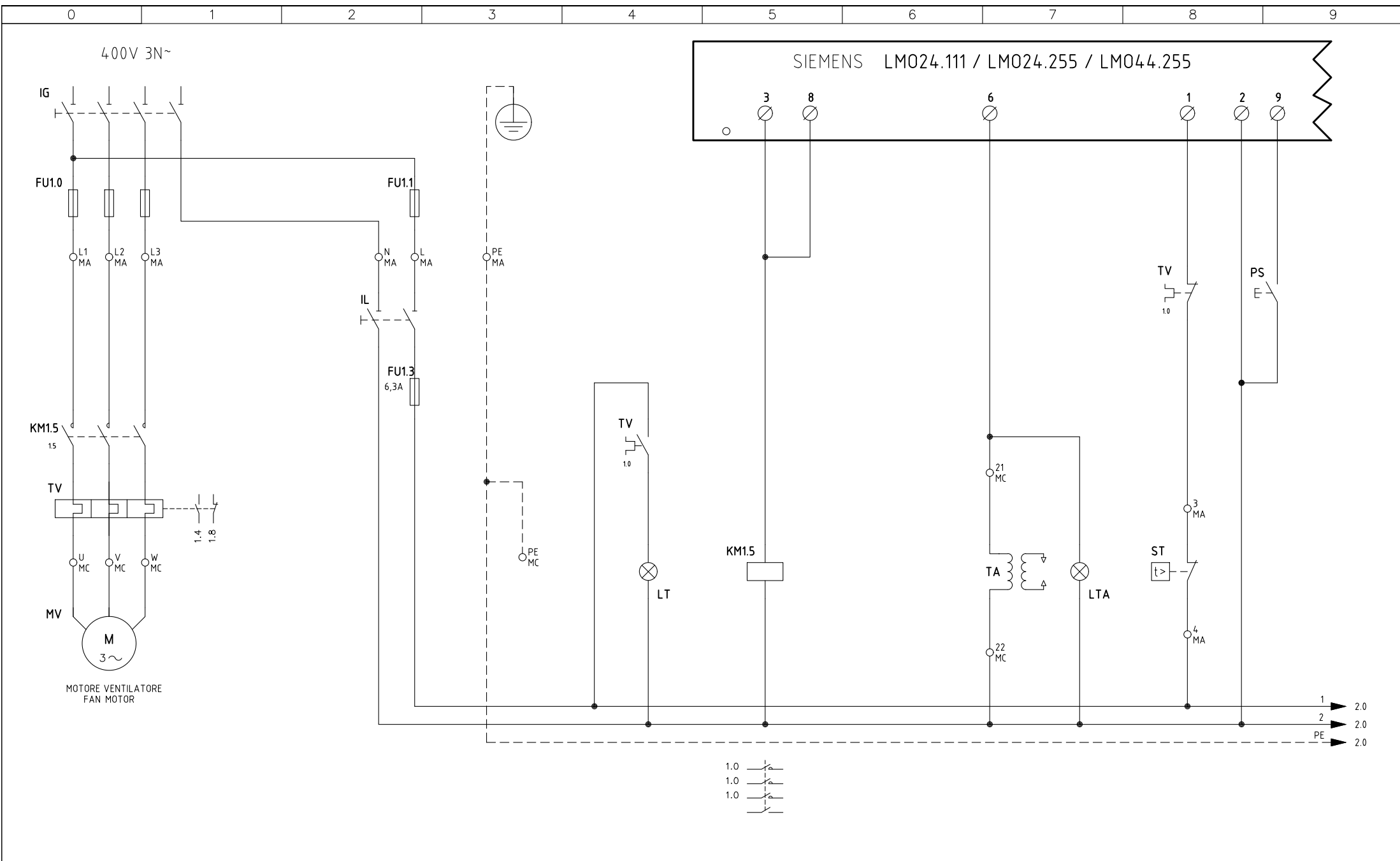

| | | | |
|------|--------------------------------------|----------|-----------|
| 05 | AGGIUNTO/ADDED "POMAX" | 30/07/12 | U. PINTON |
| 04 | SQN72.4A4A20 ADDED AND MICRO REMOVED | 00/05/10 | U. PINTON |
| 03 | SERVO-CONTROL MICRO MODIFIED | 06/04/05 | U. PINTON |
| 02 | LM024/44 ADDED | 17/12/01 | U. PINTON |
| 06 | AGGIUNTO/ADDED LM024.255 | 07/01/13 | U. PINTON |
| REV. | MODIFICA | DATA | FIRME |



| | |
|-------------|--|
| Impianto | TIPI/TYPES PG30 / PG60 MODELLO/MODEL G-.PR.x.xx.A |
| Descrizione | |

| | |
|------------------------|--------------------------------|
| Ordine | |
| Commessa | Data Controllato 07/01/2013 |
| Esecutore U. PINTON | Controllato S. MARCHETTI |

| | | | |
|-----------|------------|-------|--------|
| Data | 03/07/1997 | PREC. | FOGLIO |
| Revisione | 06 | / | 1 |
| Dis. N. | 05 - 0556 | SEGUE | TOTALE |
| | | 2 | 4 |

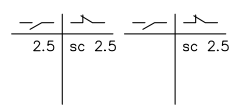
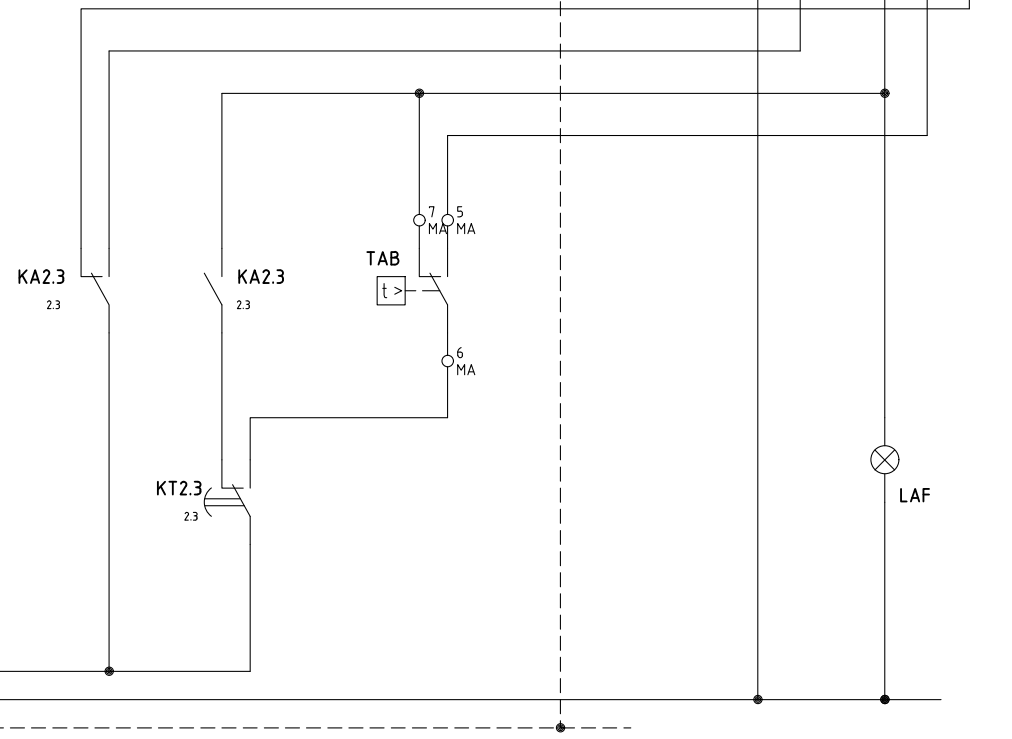
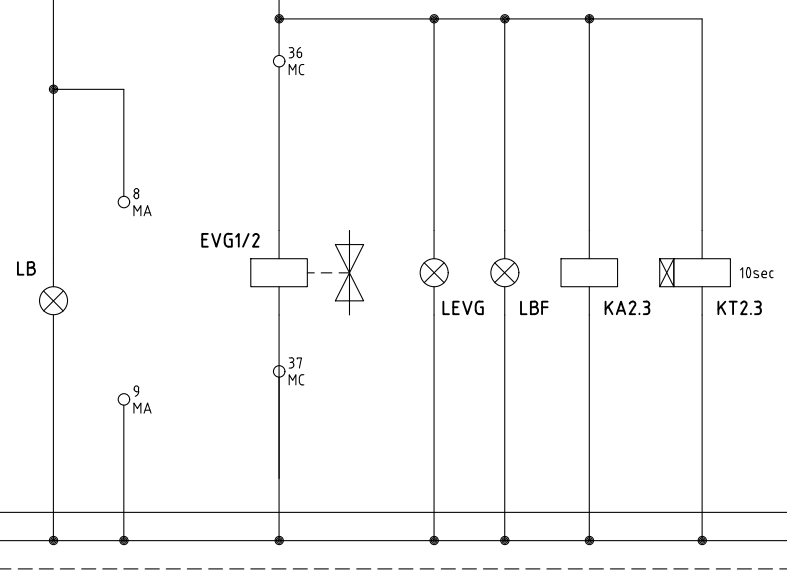
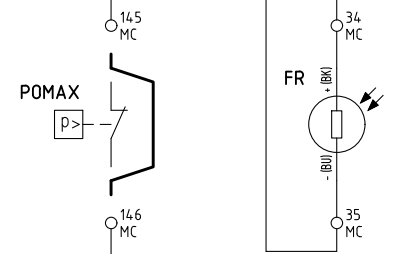
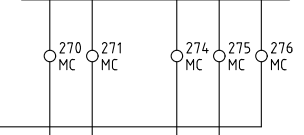
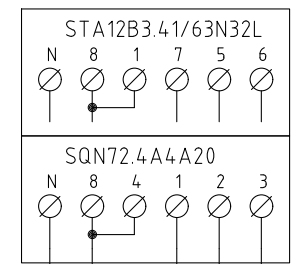
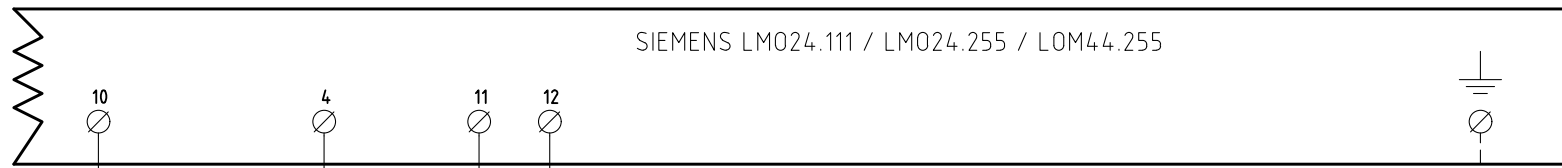

| | | | |
|-----------|------------|-------|--------|
| Data | 03/07/1997 | PREC. | FOGLIO |
| Revisione | 06 | 1 | 2 |
| Dis. N. | 05 - 0556 | SEGUE | TOTALE |
| | | 3 | 4 |

QUADRO QG - MORSETTIERA MA
 MORSETTIERA ALIMENTAZIONE
 SUPPLY TERMINAL BOARD

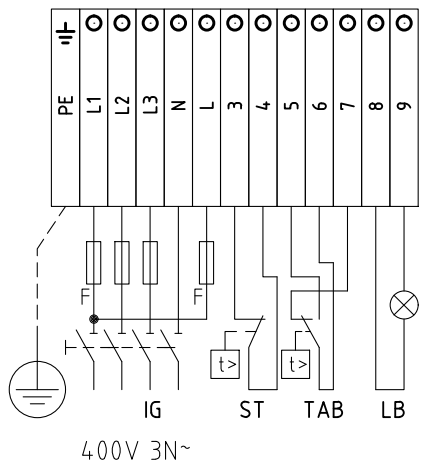

SERVOCOMANDO SERRANDA ARIA
 AIR DAMPER ACTUATOR
 BERGER STA12B3.41/63N32L

- ST2 ALTA FIAMMA
HIGH FLAME
- ST0 SOSTA E ACCENSIONE
STAND-BY AND IGNITION
- ST1 BASSA FIAMMA
LOW FLAME

QUADRO QG - MORSETTIERA MC
 MORSETTIERA COMPONENTI BRUCIATORE
 BURNER COMPONENT TERMINAL BOARD

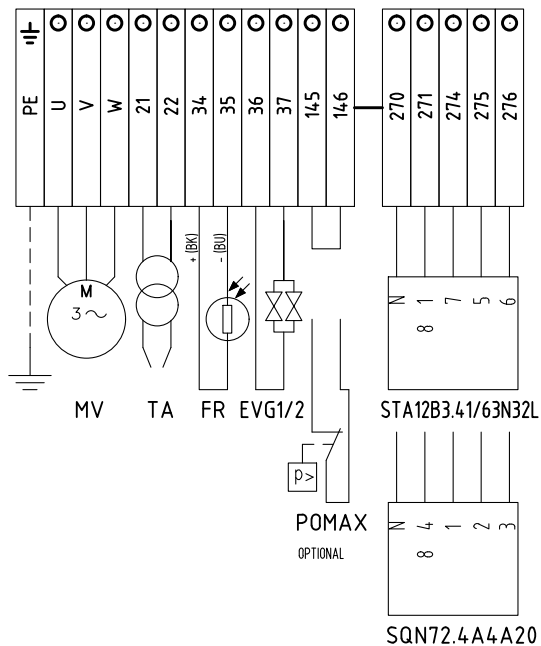

SERVOCOMANDO SERRANDA ARIA (ALTERNATIVO)
 AIR DAMPER ACTUATOR (ALTERNATIVE)
 SIEMENS SQN72.4A4A20

- I (ROSSO) ALTA FIAMMA
I (RED) HIGH FLAME
- II (BLU) SOSTA E ACCENSIONE
II (BLUE) STAND-BY AND IGNITION
- III (ARANCIO) BASSA FIAMMA
III (ORANGE) LOW FLAME

| | | | |
|-----------|------------|-------|--------|
| Data | 03/07/1997 | PREC. | FOGLIO |
| Revisione | 06 | 2 | 3 |
| Dis. N. | 05 - 0556 | SEGUE | TOTALE |
| | | 4 | 4 |

| SIGLA/ITEM | FOGLIO/SHEET | FUNZIONE | FUNCTION |
|-----------------------------------|--------------|--|--|
| EVG1/2 | 2 | ELETTROVALVOLE GASOLIO | LIGHT OIL ELECTRO VALVE |
| FR | 2 | FOTORESISTENZA RILEVAZIONE FIAMMA | PHOTORESISTOR FLAME DETECTOR |
| FU1.0 | 1 | FUSIBILI DI LINEA | LINE FUSES |
| FU1.1 | 1 | FUSIBILE DI LINEA | LINE FUSE |
| FU1.3 | 1 | FUSIBILE LINEA AUSILIARI | AUXILIARY LINE FUSE |
| IG | 1 | INTERRUTTORE GENERALE | MAINS SWITCH |
| IL | 1 | INTERRUTTORE LINEA AUSILIARI | AUXILIARY LINE SWITCH |
| KA2.3 | 2 | RELE' AUSILIARIO | AUXILIARY RELAY |
| KM1.5 | 1 | CONTATTORE MOTORE VENTILATORE | FAN MOTOR CONTACTOR |
| KT2.3 | 2 | RELE' TEMPORIZZATORE | DELAYED RELAY |
| LAF | 2 | LAMPADA SEGNALAZIONE ALTA FIAMMA BRUCIATORE | BURNER IN HIGH FLAME INDICATOR LIGHT |
| LB | 2 | LAMPADA SEGNALAZIONE BLOCCO FIAMMA | BURNER LOCK-OUT INDICATOR LIGHT |
| LBF | 2 | LAMPADA SEGNALAZIONE BASSA FIAMMA BRUCIATORE | BURNER IN LOW FLAME INDICATOR LIGHT |
| LEVG | 2 | LAMPADA SEGNALAZIONE APERTURA EVG | INDICATOR LIGHT FOR OPENING OF ELECTRO-VALVE EVG |
| LM024.111 / LM024.255 / LM044.255 | 1 | APPARECCHIATURA CONTROLLO FIAMMA | CONTROL BOX |
| LT | 1 | LAMPADA SEGNALAZIONE BLOCCO TERMICO MOTORE VENTILATORE | INDICATOR LIGHT FOR FAN OVERLOAD TRIPPED |
| LTA | 1 | LAMPADA SEGNALAZIONE TRASFORMATORE DI ACCENSIONE | IGNITION TRANSFORMER INDICATOR LIGHT |
| MV | 1 | MOTORE VENTILATORE | FAN MOTOR |
| POMAX | 2 | PRESSOSTATO DI MASSIMA PRESSIONE OLIO (OPTIONAL) | MAXIMUM OIL PRESSURE SWITCH (OPTIONAL) |
| PS | 1 | PULSANTE SBLOCCO FIAMMA (SOLO CON LM024) | LOCK-OUT RESET BUTTON (LM024 ONLY) |
| SQN72.4A4A20 | 2 | SERVOCOMANDO SERRANDA ARIA (ALTERNATIVO) | AIR DAMPER ACTUATOR (ALTERNATIVE) |
| ST | 1 | SERIE TERMOSTATI/PRESSOSTATI | SERIES OF THERMOSTATS OR PRESSURE SWITCHES |
| STA12B3.41/63N32L | 2 | SERVOCOMANDO SERRANDA ARIA | AIR DAMPER ACTUATOR |
| TA | 1 | TRASFORMATORE DI ACCENSIONE | IGNITION TRANSFORMER |
| TAB | 2 | TERMOSTATO/PRESSOSTATO ALTA-BASSA FIAMMA | HIGH-LOW THERMOSTAT/PRESSURE SWITCHES |
| TV | 1 | TERMICO MOTORE VENTILATORE | FAN MOTOR THERMAL |

| | | | |
|-----------|------------|-------|--------|
| Data | 03/07/1997 | PREC. | FOGLIO |
| Revisione | 06 | 3 | 4 |
| Dis. N. | 05 - 0556 | SEGUE | TOTALE |
| | | / | 4 |