

LO550

IDEA series

Light oil burners



MANUAL OF INSTALLATION - USE - MAINTENANCE

CIB UNIGAS

BURNERS - BRUCIATORI - BRULERS - BRENNER - QUEMADORES - ГОРЕЛКИ

TABLE OF CONTENTS

WARNINGS	3
PART I: INSTALLATION	5
GENERAL FEATURES 5	
<i>How to interpret the burner's "Performance curve"</i>	5
<i>Specifications</i>	6
<i>Performance curves</i>	6
<i>Overall dimensions</i>	7
MOUNTINGS AND CONNECTIONS	8
<i>Packing</i>	8
<i>Handling the burner</i>	8
<i>Fitting the burner to the boiler</i>	8
<i>Electrical connections</i>	9
<i>Installation diagram of light oil pipes</i>	11
<i>Bleed</i>	11
<i>About the use of fuel pumps</i>	11
<i>Oil pump</i>	12
<i>Connecting the light oil flexible hoses</i>	12
ADJUSTMENTS	13
<i>Adjusting the fuel flow rate</i>	13
<i>Priming the pump and adjusting the burner for single stage burners</i>	14
<i>Priming the pump and adjustments for double stage burners</i>	15
<i>Adjusting the combustion head</i>	16
PART II: OPERATION	17
OPERATION	17
<i>Single stage burners</i>	17
<i>Double stage burners</i>	17
<i>Burner control panel</i>	18
PART III: MAINTENANCE	19
ROUTINE MAINTENANCE	19
<i>Light oil filter maintenance</i>	19
<i>Removing the combustion head and the oil gun</i>	20
<i>Removing burner components plate</i>	21
<i>Removing the electrodes</i>	22
<i>Removing the nozzles</i>	22
<i>Checking the detection current</i>	23
<i>Cleaning and replacing the detection photoresistor</i>	24
<i>Burner control panel disassembly</i>	24
<i>Seasonal stop</i>	24
<i>Burner disposal</i>	24
TROUBLESHOOTING	25
BURNER EXPLODED VIEW	26
SPARE PARTS	28
ELECTRICAL WIRING DIAGRAMS	
APPENDIX	

WARNINGS

THIS MANUAL IS SUPPLIED AS AN INTEGRAL AND ESSENTIAL PART OF THE PRODUCT AND MUST BE DELIVERED TO THE USER.

INFORMATION INCLUDED IN THIS SECTION ARE DEDICATED BOTH TO THE USER AND TO PERSONNEL FOLLOWING PRODUCT INSTALLATION AND MAINTENANCE.

THE USER WILL FIND FURTHER INFORMATION ABOUT OPERATING AND USE RESTRICTIONS, IN THE SECOND SECTION OF THIS MANUAL. WE HIGHLY RECOMMEND TO READ IT.

CAREFULLY KEEP THIS MANUAL FOR FUTURE REFERENCE.

1) GENERAL INTRODUCTION

- The equipment must be installed in compliance with the regulations in force, following the manufacturer's instructions, by qualified personnel.
- Qualified personnel means those having technical knowledge in the field of components for civil or industrial heating systems, sanitary hot water generation and particularly service centres authorised by the manufacturer.
- Improper installation may cause injury to people and animals, or damage to property, for which the manufacturer cannot be held liable.
- Remove all packaging material and inspect the equipment for integrity.

In case of any doubt, do not use the unit - contact the supplier.

The packaging materials (wooden crate, nails, fastening devices, plastic bags, foamed polystyrene, etc), should not be left within the reach of children, as they may prove harmful.

- Before any cleaning or servicing operation, disconnect the unit from the mains by turning the master switch OFF, and/or through the cut-out devices that are provided.
- Make sure that inlet or exhaust grilles are unobstructed.
- In case of breakdown and/or defective unit operation, disconnect the unit. Make no attempt to repair the unit or take any direct action.

Contact qualified personnel only.

Units shall be repaired exclusively by a servicing centre, duly authorised by the manufacturer, with original spare parts.

Failure to comply with the above instructions is likely to impair the unit's safety.

To ensure equipment efficiency and proper operation, it is essential that maintenance operations are performed by qualified personnel at regular intervals, following the manufacturer's instructions.

- When a decision is made to discontinue the use of the equipment, those parts likely to constitute sources of danger shall be made harmless.
- In case the equipment is to be sold or transferred to another user, or in case the original user should move and leave the unit behind, make sure that these instructions accompany the equipment at all times so that they can be consulted by the new owner and/or the installer.
- For all the units that have been modified or have options fitted then original accessory equipment only shall be used.
- This unit shall be employed exclusively for the use for which it is meant. Any other use shall be considered as improper and, therefore, dangerous.

The manufacturer shall not be held liable, by agreement or otherwise, for damages resulting from improper installation, use and failure to comply with the instructions supplied by the manufacturer.

2) SPECIAL INSTRUCTIONS FOR BURNERS

- The burner should be installed in a suitable room, with ventilation openings complying with the requirements of the regulations in force, and sufficient for good combustion.
- Only burners designed according to the regulations in force should be used.
- This burner should be employed exclusively for the use for which it was designed.
- Before connecting the burner, make sure that the unit rating is the same as delivery mains (electricity, gas oil, or other fuel).
- Observe caution with hot burner components. These are, usually, near to the flame and the fuel pre-heating system, they become hot during the unit operation and will remain hot for some time after the burner has stopped.

When the decision is made to discontinue the use of the burner, the user

shall have qualified personnel carry out the following operations:

- a Remove the power supply by disconnecting the power cord from the mains.
- b) Disconnect the fuel supply by means of the hand-operated shut-off valve and remove the control handwheels from their spindles.

Special warnings

- Make sure that the burner has, on installation, been firmly secured to the appliance, so that the flame is generated inside the appliance firebox.
- Before the burner is started and, thereafter, at least once a year, have qualified personnel perform the following operations:
 - a set the burner fuel flow rate depending on the heat input of the appliance;
 - b set the flow rate of the combustion-supporting air to obtain a combustion efficiency level at least equal to the lower level required by the regulations in force;
 - c check the unit operation for proper combustion, to avoid any harmful or polluting unburnt gases in excess of the limits permitted by the regulations in force;
 - d make sure that control and safety devices are operating properly;
 - e make sure that exhaust ducts intended to discharge the products of combustion are operating properly;
 - f on completion of setting and adjustment operations, make sure that all mechanical locking devices of controls have been duly tightened;
 - g make sure that a copy of the burner use and maintenance instructions is available in the boiler room.
- In case of a burner shut-down, reset the control box by means of the RESET pushbutton. If a second shut-down takes place, call the Technical Service, **without trying to RESET further**.
- The unit shall be operated and serviced by qualified personnel only, in compliance with the regulations in force.

3) GENERAL INSTRUCTIONS DEPENDING ON FUEL USED

3a) ELECTRICAL CONNECTION

- For safety reasons the unit must be efficiently earthed and installed as required by current safety regulations.
 - It is vital that all safety requirements are met. In case of any doubt, ask for an accurate inspection of electricians by qualified personnel, since the manufacturer cannot be held liable for damages that may be caused by failure to correctly earth the equipment.
 - Qualified personnel must inspect the system to make sure that it is adequate to take the maximum power used by the equipment shown on the equipment rating plate. In particular, make sure that the system cable cross section is adequate for the power absorbed by the unit.
 - No adaptors, multiple outlet sockets and/or extension cables are permitted to connect the unit to the electric mains.
 - An omnipolar switch shall be provided for connection to mains, as required by the current safety regulations.
 - The use of any power-operated component implies observance of a few basic rules, for example:
 - do not touch the unit with wet or damp parts of the body and/or with bare feet;
 - do not pull electric cables;
 - do not leave the equipment exposed to weather (rain, sun, etc.) unless expressly required to do so;
 - do not allow children or inexperienced persons to use equipment;
 - The unit input cable shall not be replaced by the user.
- In case of damage to the cable, switch off the unit and contact qualified personnel to replace.
- When the unit is out of use for some time the electric switch supplying all the power-driven components in the system (i.e. pumps, burner, etc.) should be switched off.

3b) FIRING WITH GAS, LIGHT OIL OR OTHER FUELS

GENERAL

- The burner shall be installed by qualified personnel and in compliance with regulations and provisions in force; wrong installation can cause injuries to people and animals, or damage to property, for which the manufacturer cannot be held liable.
- Before installation, it is recommended that all the fuel supply system pipes be carefully cleaned inside, to remove foreign matter that might impair the burner operation.
- Before the burner is commissioned, qualified personnel should inspect the following:
 - a the fuel supply system, for proper sealing;
 - b the fuel flow rate, to make sure that it has been set based on the firing rate required of the burner;
 - c the burner firing system, to make sure that it is supplied for the designed fuel type;
 - d the fuel supply pressure, to make sure that it is included in the range shown on the rating plate;
 - e the fuel supply system, to make sure that the system dimensions are adequate to the burner firing rate, and that the system is equipped with all the safety and control devices required by the regulations in force.
- When the burner is to remain idle for some time, the fuel supply tap or taps should be closed.

SPECIAL INSTRUCTIONS FOR USING GAS

Have qualified personnel inspect the installation to ensure that:

- a the gas delivery line and train are in compliance with the regulations and provisions in force;
 - b all gas connections are tight;
 - c the boiler room ventilation openings are such that they ensure the air supply flow required by the current regulations, and in any case are sufficient for proper combustion.
- Do not use gas pipes to earth electrical equipment.
 - Never leave the burner connected when not in use. Always shut the gas valve off.
 - In case of prolonged absence of the user, the main gas delivery valve to the burner should be shut off.

Precautions if you can smell gas

- a do not operate electric switches, the telephone, or any other item likely to generate sparks;
 - b immediately open doors and windows to create an air flow to purge the room;
 - c close the gas valves;
 - d contact qualified personnel.
- Do not obstruct the ventilation openings of the room where gas appliances are installed, to avoid dangerous conditions such as the development of toxic or explosive mixtures.

DIRECTIVES AND STANDARDS

Gas burners

European directives:

- Directive 90/396/CEE - Gas Appliances;
- Directive 2006/95/EC on low voltage;
- Directive 2004/108/CEE on electromagnetic compatibility

Harmonised standards :

- UNI EN 676 (Gas Burners);
- CEI EN 60335-1(Household and similar electrical appliances - Safety. Part 1: General requirements;
- EN 50165 (Electrical equipment of non-electric appliances for household and similar purposes. Safety requirements.

Light oil burners

European directives:

- Directive 2006/95/EC on low voltage;
- Directive 2004/108/CEE on electromagnetic compatibility

Harmonised standards :

- CEI EN 60335-1(Household and similar electrical appliances - Safety. Part 1: General requirements;
- EN 50165 (Electrical equipment of non-electric appliances for household and similar purposes. Safety requirements.

National standards :

- UNI 7824: Monobloc nebulizer burners for liquid fuels. Characteristics and test methods

Heavy oil burners

European directives:

- Directive 2006/95/EC on low voltage;
- Directive 2004/108/CEE on electromagnetic compatibility

Harmonised standards :

- CEI EN 60335-1 Household and similar electrical appliances - SafetyPart 1: General requirements;
- EN 50165 Electrical equipment of non-electric appliances for household and similar purposes. Safety requirements.

National standards :

- UNI 7824: Monobloc nebulizer burners for liquid fuels. Characteristics and test methods

Gas - Light oil burners

European directives:

- Directive 90/396/CEE Gas Appliances;
- Directive 2006/95/EC on low voltage;
- Directive 2004/108/CEE on electromagnetic compatibility

Harmonised standards :

- UNI EN 676 Gas Burners
- CEI EN 60335-1(Household and similar electrical appliances - Safety. Part 1: General requirements;
- EN 50165 Electrical equipment of non-electric appliances for household and similar purposes. Safety requirements.

National standards :

- UNI 7824: Monobloc nebulizer burners for liquid fuels. Characteristics and test methods

Gas - Heavy oil burners

European directives:

- Directive 90/396/CEE - Gas Appliances;
- Directive 2006/95/EC on low voltage;
- Directive 2004/108/CEE on electromagnetic compatibility

Harmonised standards :

- UNI EN 676 (Gas Burners);
- CEI EN 60335-1(Household and similar electrical appliances - Safety. Part 1: General requirements;
- EN 50165 Electrical equipment of non-electric appliances for household and similar purposes. Safety requirements.

National standards :

- UNI 7824: Monobloc nebulizer burners for liquid fuels. Characteristics and test methods

PART I: INSTALLATION

GENERAL FEATURES

These burners are characterised by high performances and width in the performance curves, when the pressure in the combustion chamber is high. They are also characterised for other important functional features: there are plugs which can be easily connected to the boiler and to the detecting probes, a pressure plug in the combustion chamber, all mechanical components are mounted on a plate which can be quickly taken off for maintenance. The head is adjustable through a graduated screw. The gas train can be mounted either on the right side or on the left side.

The fuel coming from the supply line, is pushed by the pump to the nozzle and then into the combustion chamber, where the mixture between fuel and air takes place and consequently the flame.

In the burners, the mixture between fuel and air, to perform clean and efficient combustion, is activated by atomisation of oil into very small particles. This process is achieved making pressurised oil pass through the nozzle.

The pump main function is to transfer oil from the tank to the nozzle at required quantity and pressure. To adjust pressure, pumps are provided with a pressure governor.

The electric actuator moves the air damper and allows the optimisation of the gas flue values, as to get an efficient combustion. The position of the combustion head determines the burner output. The air (comburent) and fuel (light oil) are forced into the combustion chamber, as to let the flame light up.

How to interpret the burner's "Performance curve"

To check if the burner is suitable for the boiler to which it must be installed, the following parameters are needed:

- furnace input, in kW or kcal/h ($\text{kW} = \text{kcal/h} / 860$);
- backpressure (data are available on the boiler ID plate or in the user's manual).

Example:

Furnace input: 600kW

Backpressure: 4mbar

In the "Performance curve" diagram (Fig. 1), draw a vertical line matching the furnace input value and an horizontal line matching the backpressure value. The burner is suitable if the intersection point A is inside the performance curve.

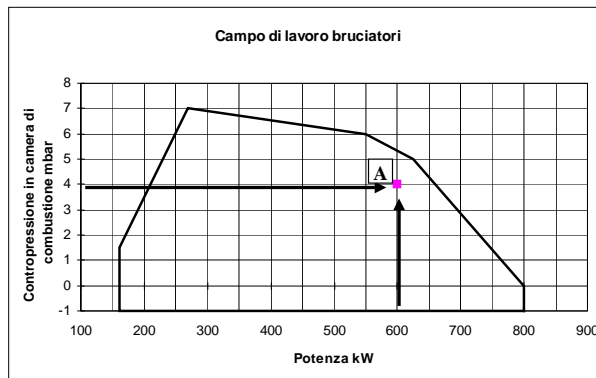

Fig. 1

Data are referred to standard conditions: atmospheric pressure at 1013mbar, ambient temperature at 15°C

Burner model identification

Burners are identified by burner type and model. Burner model identification is described as follows.

Type	LO550	Model	G-	AB.	S.	*	A.
(1)	(2)	(3)	(4)	(5)	(6)		
(1) BURNER TYPE	LO550						
(2) FUEL	G - Light oil A - Biodiesel						
(3) OPERATION(Available versions)	TN - Single-stage			AB - Double-stage			
(4) BLAST TUBE	S - Standard			L - Extended			
(5) DESTINATION COUNTRY	* - see data plate						
(6) BURNER VERSION	A - Standard						

Specifications

BURNERS		LO550	LO550
		G-TN.x.xx.A	G-AB.x.xx.A
Output	min. - max. kW	200 - 560	160 - 560
Fuel		Light oil	
Light oil rate	min. - max. kg/h	17 - 47	13,5 - 47
Viscosity	cSt @ 20 °C	2 - 7,4	
Oil inlet pressure	bar	2 max	
Power supply		220V-230V 1N a.c. 50Hz-60Hz 220V 2 a.c. 50Hz-60Hz	
Electric motor	kW	0,62	
Total power consumption	kW	0,92	
Index of protection		IP40	
Approx. weight	kg	50	
Operation		Single stage	Double stage
Operating temperature	°C	-10 ÷ +50	
Storage Temperature	°C	-20 ÷ +60	
Working service*		Intermittent	

*NOTE ON THE BURNER WORKING SERVICE:

- Burners provided with Siemens LOA24 control box: for safety reasons, one controlled shutdown must take place every 24 hours.
- Burners provided with Siemens LMO24-44 control box: the control box automatically stops after 24h of continuous working. The control box immediately starts up, automatically.

⚠ CAUTION: in case the fuel requested is biodiesel, some components must be replaced. Please, contact our Technical Dept. for further details.

Performance curves

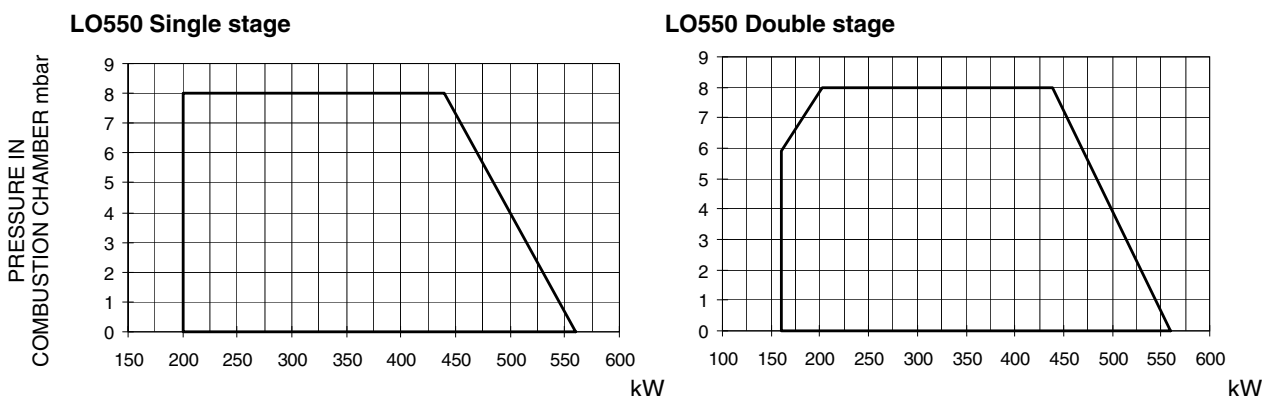

Data are referred to standard conditions: atmospheric pressure at 1013mbar, ambient temperature at 15°C

NOTE: The performance curve is a diagram that represents the burner performance in the type approval phase or in the laboratory tests, but does not represent the regulation range of the machine. On this diagram the maximum output point is usually reached by adjusting the combustion head to its "MAX" position (see paragraph "Adjusting the combustion head"); the minimum output point is reached setting the combustion head to its "MIN" position. During the first ignition, the combustion head is set in order to find a compromise between the burner output and the generator specifications, that is why the minimum output may be different from the Performance curve minimum.

Overall dimensions (mm)

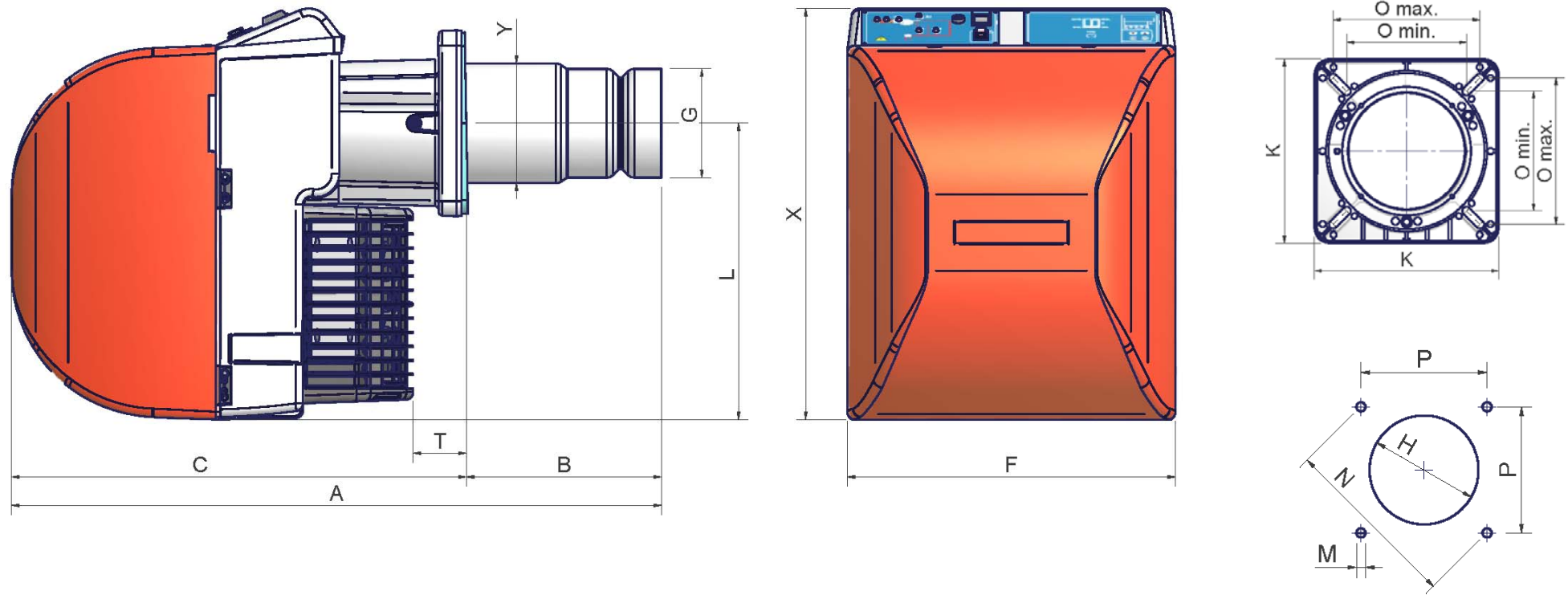

		A(S*)	A(L*)	B(S*)	B(L*)	C	F	G	H	K	L	M	N	Omin	Omax	P	T	X	Y
LO550	G-.TN.x.xx.A	843	943	253	353	590	426	141	175	241	384	M10	247	157	192	174	69	533	155
LO550	G-.AB.x.xx.A	843	943	253	353	590	426	141	175	241	384	M10	274	157	192	174	69	533	155

* S = STANDARD BLAST TUBE

* L = EXTENDED BLAST TUBE

MOUNTINGS AND CONNECTIONS

Packing

Burners are dispatched in cardboard packages whose dimensions are: 1030mmx530mmx270mm (LxPxH)
Packing cases of this kind are affected by humidity and are not suitable for stacking. The following are placed in each packing case.

- 1 burner;
- 2 light oil flexible hoses;
- 1 light oil filter;
- 1 gasket to be inserted between the burner and the boiler;
- 1 envelope containing this manual.

To get rid of the burner's packing, follow the procedures laid down by current laws on disposal of materials.

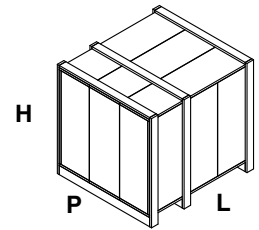

Handling the burner



ATTENTION! The handling operations must be carried out by specialised and trained personnel. If these operations are not carried out correctly, the residual risk for the burner to overturn and fall down still persists.

To move the burner, use means suitable to support its weight (see paragraph "Technical specifications").

Fitting the burner to the boiler

To install the burner into the boiler, proceed as follows:

- 1 make a hole on the closing door of the combustion chamber as described on paragraph "Overall dimensions")
- 2 place the burner to the boiler: lift it up and handle it according to the procedure described on paragraph "Handling the burner";
- 3 place the 4 stud bolts (5) on boiler's door, according to the burner's drilling template described on paragraph "Overall dimensions";
- 4 fasten the 4 stud bolts;
- 5 place the gasket on the burner flange;
- 6 install the burner into the boiler;
- 7 fix the burner to the stud bolts, by means of the fixing nuts, according to the next picture.
- 8 After fitting the burner to the boiler, ensure that the gap between the blast tube and the refractory lining is sealed with appropriate insulating material (ceramic fibre cord or refractory cement).

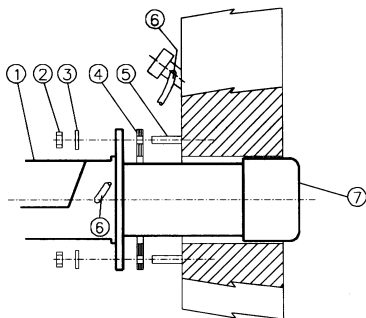

Keys

- 1 Burner
- 2 Fixing nut
- 3 Washer
- 4 Sealing gasket
- 5 Stud bolt
- 7 Blast tube

The burner is designed to work positioned according to the picture below. For different installations, please contact the Technical Department.

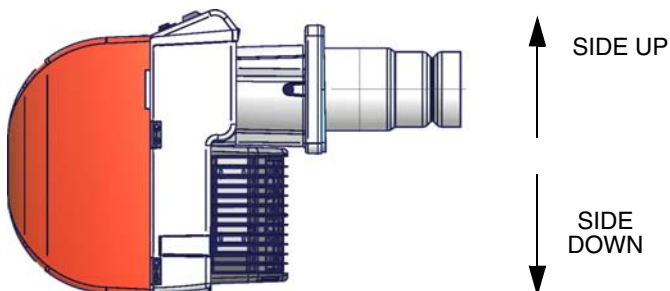

Electrical connections

	<p>Respect the basic safety rules. make sure of the connection to the earthing system. do not reverse the phase and neutral connections. fit a differential thermal magnet switch adequate for connection to the mains.</p>
	<p>ATTENTION: before executing the electrical connections, pay attention to turn the plant's switch to OFF and be sure that the burner's main switch is in 0 position (OFF) too. Read carefully the chapter "WARNINGS", and the "Electrical connections" section.</p>

	<p>WARNING: the burner is fitted with a bridge between terminals T6 and T8 on CN2-TAB connector (external side link, male connector); remove this bridge before thermostat connection.</p>
---	---

To execute the electrical connections, proceed as follows:

- 1 find the plug or the plugs, according to the model:
 - 7 poles plug for the power supply (for all models);
 - 4 poles plug (double-stage burners);
 - 3-poles plug;
- 2 execute the electrical connections to the plugs, according to hte burner model (see next paragraph);
- 3 once all the connections are accomplished, check the fan motor direction (sse next paragraphs);
- 4 now the burner is ready to start up.

Identification of linking connectors

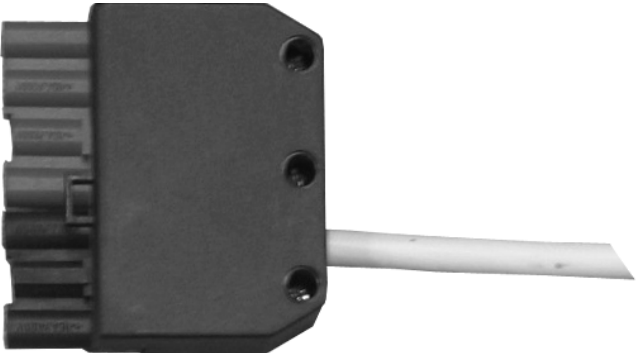
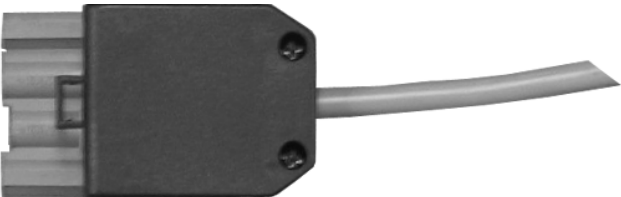
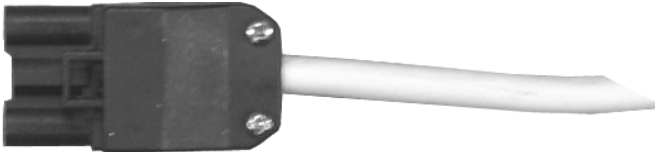
<p>Burner mains supply connector (Fig. 5, Fig. 7)</p>	 <p>Fig. 2</p>
<p>HIGH/LOW flame connector (progressive burners, Fig. 7)</p>	 <p>Fig. 3</p>
<p>Fan motor connector (Fig. 6 - Fig. 8)</p>	 <p>Fig. 4</p>

	<p>IMPORTANT: before operating the burner, be sure all connectors are linked as shown in the diagrams.</p>
--	---

● **Single stage burner connectors:**

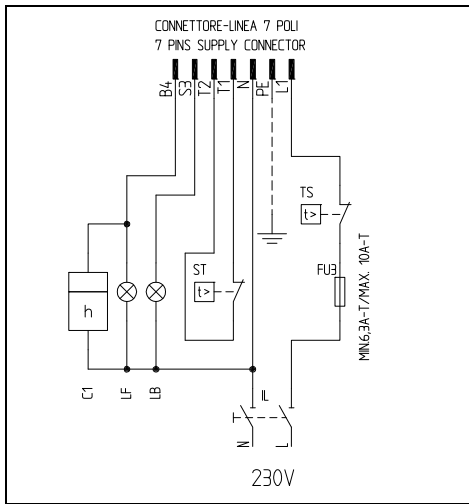

Fig. 5 - 7-poles connector

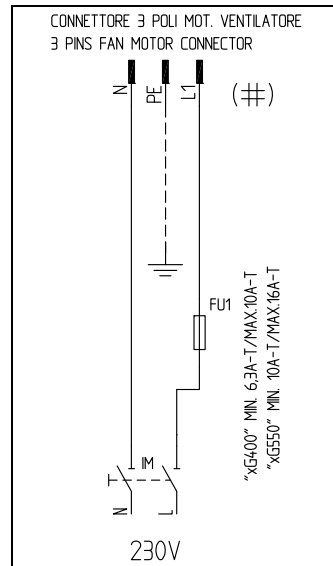

Fig. 6 - Electric motor 3-pole connector

● **Double-stage burner connectors:**

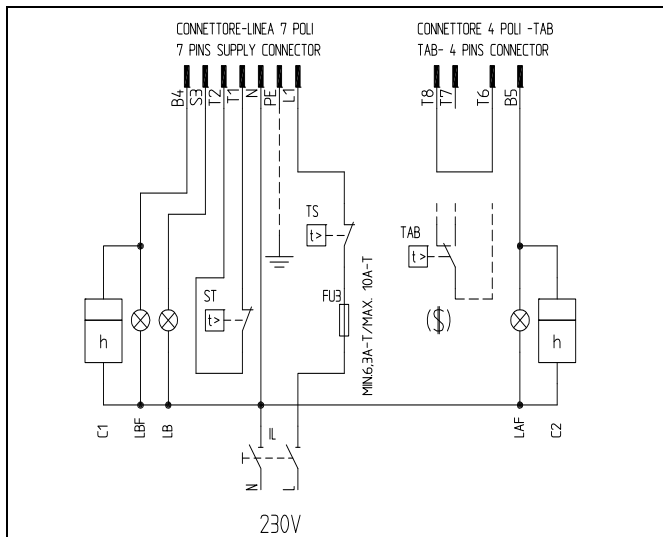

Fig. 7 7-poles and 4-poles connectors

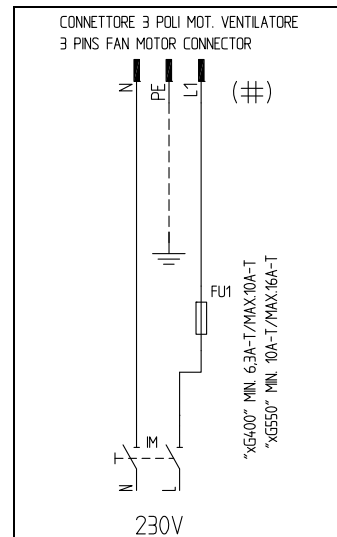

Fig. 8 Electric motor 3-poles connector

Key

- C1 LOW FLAME TIME METER
- C2 HIGH FLAME TIME METER
- FU1 FAN MOTOR LINE FUSE
- FU3 LINE FUSE
- IL BURNER LINE SWITCH
- IM FAN MOTOR LINE SWITCH
- KM1 FAN MOTOR CONTACTOR
- LAF BURNER IN HIGH FLAME INDICATOR LIGHT
- LB INDICATOR LIGHT FOR BURNER LOCK-OUT

- LBF BURNER IN LOW FLAME SIGNALLING LAMP
- MV FAN MOTOR
- ST THERMOSTATS O PRESSURE SWITCHES SERIE
- TAB HIGH LOW FLAME THERMOSTAT/PRESSURE SWITCH
- TS SAFETY THERMOSTAT/PRESSURE SWITCH
- CONN-MOTORE FAN MOTOR CONNECTOR
- CONN-LINEA BURNER POWER SUPPLY CONNNECTOR
- CONN-TAB HIGH-LOW FLAME CONNECTOR
- (\$) IF "TAB" USED REMOVE THE BRIDGE BETWEEN TERMINALS T6-T8

Installation diagram of light oil pipes

⚠ PLEASE READ CAREFULLY THE “WARNINGS” CHAPTER AT THE BEGINNING OF THIS MANUAL.

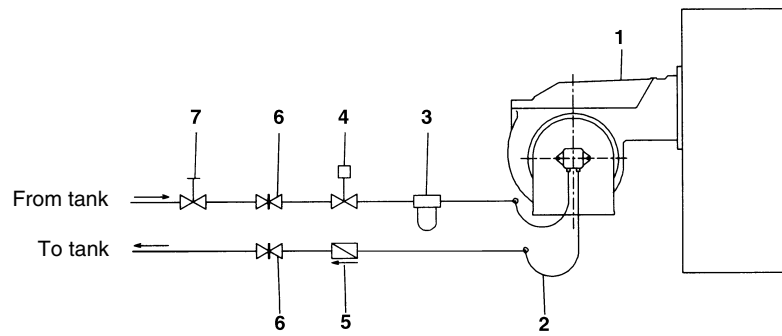

Fig. 9 - Double-pipe system

The burner is supplied with filter and flexible hoses, all the parts upstream the filter and downstream the return flexible hose, must be installed by the customer. As far as the hoses connection, see the related paragraph.

Key

- 1 Burner
- 2 Flexible hoses (fitted)
- 3 Light oil filter (fitted)
- 4 Automatic interceptor (*)
- 5 One-way valve (*)
- 6 Gate valve
- 7 Quick-closing gate-valve (outside the tank or boiler rooms)

(*) Only for installations with gravity, siphon or forced circulation feed systems. If the device installed is a solenoid valve, a timer must be installed to delay the valve closing. The direct connection of the device without a timer may cause pump breaks.

The provided pumps can be installed both into single-pipe and double-pipe systems.

Single-pipe system: a single pipe drives the oil from the tank to the pump's inlet. Then, from the pump, the pressurised oil is driven to the nozzle: a part comes out from the nozzle while the other part goes back to the pump. In this system, the by-pass plug, if provided, must be removed and the optional return port, on the pump's body, must be sealed by steel plug and washer.

Double-pipe system: as for the single pipe system, a pipe that connects the tank to the pump's inlet is used besides another pipe that connects the pump's return port to the tank, as well. The excess of oil goes back to the tank: this installation can be considered self-bleeding. If provided, the inside by-pass plug must be installed to avoid air and fuel passing through the pump.

Burners are factory-set for double-pipe systems. They can be suited for single-pipe system (recommended in the case of gravity feed) as described before.

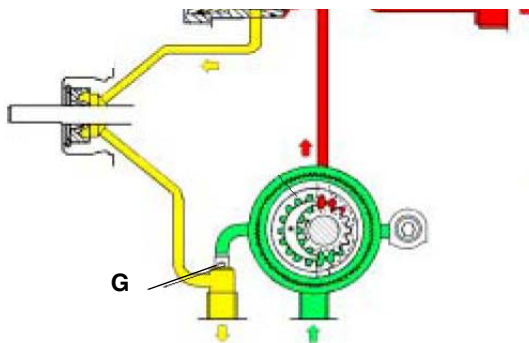

To change from a 1-pipe system to a 2-pipe-system, insert the by-pass plug **G** (as for ccw-rotation- referring to the pump shaft).

Caution: Changing the direction of rotation, all connections on top and side are reversed.

Bleed

Bleeding in two-pipe operation is automatic: it is assured by a bleed flat on the piston. In one-pipe operation, the plug of a pressure gauge port must be loosened until the air is evacuated from the system.

About the use of fuel pumps

- Make sure that the by-pass plug is not used in a single pipe installation, because the fuel unit will not function properly and damage to the pump and burner motor could result.
- Do not use fuel with additives to avoid the possible formation over time of compounds which may deposit between the gear teeth, thus obstructing them.
- After filling the tank, wait before starting the burner. This will give any suspended impurities time to deposit on the bottom of the tank, thus avoiding the possibility that they might be sucked into the pump.
- On initial commissioning a "dry" operation is foreseen for a considerable length of time (for example, when there is a long suction line to bleed). To avoid damages inject some lubrication oil into the vacuum inlet.
- Care must be taken when installing the pump not to force the pump shaft along its axis or laterally to avoid excessive wear on the joint, noise and overloading the gears.
- Pipes should not contain air pockets. Rapid attachment joint should therefore be avoided and threaded or mechanical seal junctions preferred. Junction threads, elbow joints and couplings should be sealed with removable seal component. The number of junctions should be kept to a minimum as they are a possible source of leakage.
- Do not use PTFE tape on the suction and return line pipes to avoid the possibility that particles enter circulation. These could deposit on the pump filter or the nozzle, reducing efficiency. Always use O-Rings or mechanical seal (copper or aluminium gaskets) junctions if possible.
- An external filter should always be installed in the suction line upstream of the fuel unit.

Oil pump

Pump Suntec AL65

Viscosity range	2 ÷ 12 (cSt) mm ² /s
Oil temperature	0 ÷ 60 °C
Inlet pressure	2 bar
Minimum inlet pressure	- 0,45 bar to avoid gasing
Maximum return pressure	2 bar
Rated speed	3600 rpm

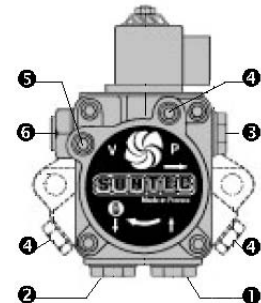

Keys

- 1 inlet (suction) G1/4
- 2 return and internal by-pass plug G1/4
- 3 outlet to the nozzle G1/8
- 4 pressure gauge port G1/8
- 5 vacuum gauge port G1/8
- 6 pressure adjusting screw

Connecting the light oil flexible hoses

To connect the flexible light oil hoses to the pump, proceed as follows, according to the pump provided:

- 1 remove the closing nuts **A** and **R** on the inlet and return connections of the pump;
- 2 screw the rotating nut of the two flexible hoses on the pump **being careful to avoid exchanging the inlet and return lines**: see the arrows marked on the pump that show the inlet and the return (see previous paragraph).

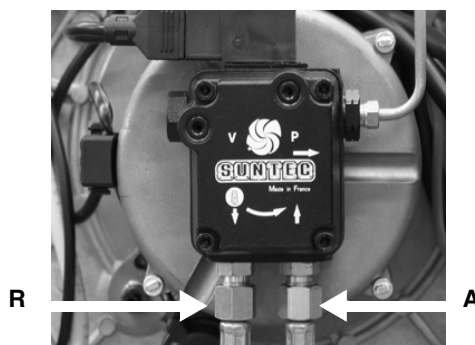

ADJUSTMENTS

	ATTENTION: before starting the burner up, be sure that the manual cutoff valves are open. Be sure that the mains switch is closed.
	Before starting up the burner, make sure that the return pipe to the tank is not obstructed. Any obstruction would cause the pump seal to break.
	ATTENTION: During commissioning operations, do not let the burner operate with insufficient air flow (danger of formation of carbon monoxide); if this should happen, make the fuel decrease slowly until the normal combustion values are achieved.

	IMPORTANT! the combustion air excess must be adjusted according to the in the following chart:
---	---

Recommended combustion parameters		
Fuel	Recommended (%) CO ₂	Recommended (%) O ₂
Light oil	11.5 ÷ 13	2.9 ÷ 4.9

Adjusting the fuel flow rate

The fuel rate is setting choosing properly sized nozzles and adjusting the fuel pressure at the pump inlet (see the diagram Fig. 10 and Fig. 11). To choose the nozzles refer to Tab. 2; for pump pressure regulation see pag. 12..

	Note: all pumps are set to 12 bar. The nozzle rate must be higher than the rate referred to the minimum burner output.
---	---

Key

EV	Fuel solenoid valve
EVG1	Fuel solenoid valve - low flame
EVG2	Fuel solenoid valve - high flame (only hi-lo flame burners)
EVGS	Safety light oil solenoid valve
M	Manometer
P	Pump

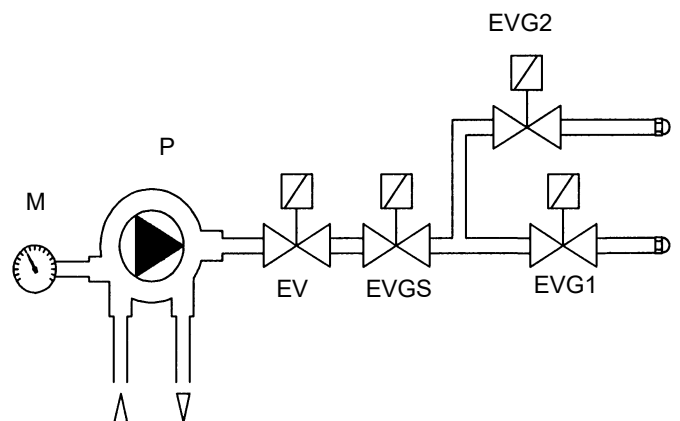

Fig. 2 - Double-stage burners

Choosing the light oil nozzles - single stage burners

NOZZLE (G.P.H.)	PUMP PRESSURE (bar)		
	10	12	14
	FUEL RATE kg/h		
4,00	15,19	16,64	17,98
4,50	17,09	18,72	20,23
5,00	18,99	20,81	22,47
5,50	20,89	22,89	24,72
6,00	22,79	24,97	26,97
6,50	24,69	27,05	29,21
7,00	26,59	29,13	31,46
7,50	28,49	31,21	33,71
8,30	31,53	34,54	37,30
9,50	36,09	39,53	42,70

Tab. 1

Choosing the light oil nozzles - double stage burners

FLOW RATE		OUTPUT kW	PUMP PRESSURE bar		
kg/h	kcal/h		10bar	12bar	14bar
30	306.300	356	3.50+4.50	3.00+4.00	3.00+3.50
35	357.350	416	4.00+5.00	3.50+5.00	3.50+4.00
40	408.400	475	4.50+6.00	4.00+5.50	4.00+5.00
45	459.450	534	5.00+6.50	4.50+6.00	4.00+6.00
50	510.500	594	5.50+7.50	5.00+7.00	4.50+6.50

Tab. 2



Prior to start up the burner, make sure that the return pipe to the tank is not obstructed. Any obstruction would cause the pump seal to break.

Priming the pump and adjusting the burner for single stage burners

- 1 remove the burner cover;
- 2 remove the solenoid valve coil **B** on pump (Fig. 13) to avoid the light oil to get into the combustion chamber;
- 3 start the burner up by means of the control panel switch (switch to ON - Fig. 20) and by means of the thermostats\pressure switches series;
- 4 when the EVG lamp turns to on (see chapter page 17) remove the photoresistor **FR** (Fig. 12) from its slot and light it up;
- 5 bleed the air from the **M** pressure gauge port of the pump, slightly loosening the cap and without removing it (Fig. 13);
- 6 turn the burner off;
- 7 replace the photoresistor **FR** (Fig. 12) into its slot;
- 8 reconnect the **B** coil on the pump (Fig. 13);
- 9 light the burner; if the burner locks, press the unlock pushbutton, placed on the upper side of the burner and repeat the steps above.
- 10 The oil flow rate depends on the choosen nozzle.
- 11 Checking the combustion values, adjust the air flow rate by means of the **VSB** (Fig. 14); screw to decrease the air rate or unscrew to increase it.
- 12 Replace the burner cover.

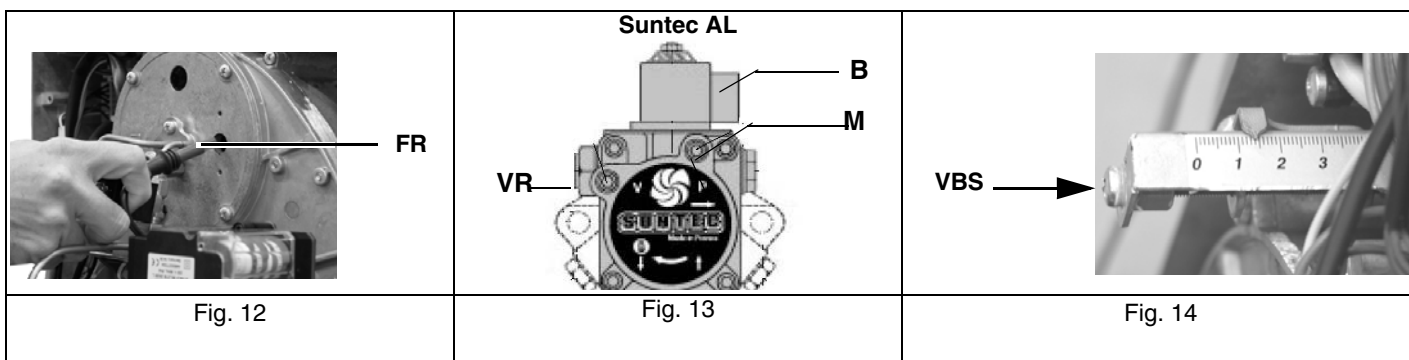

Priming the pump and adjustments for double stage burners

Before carrying out the adjustment it is necessary to start up the fuel pump, proceeding as follows:

- 1 remove the burner cover;
- 2 remove the solenoid valve coil **B** connector on pump (Fig. 15) to avoid the light oil to get into the combustion chamber;
- 3 start the burner up by means of the control panel switch (switch to ON - Fig. 20) and by means of the thermostats\pressure switches series;
- 4 when the EVG lamp turns to on (see chapter page 17) remove the photoresistor **FR** (Fig. 17) from its slot and light it up;
- 5 bleed the air from the **M** pressure gauge port of the pump, slightly loosening the cap and without removing it (Fig. 15);
- 6 turn the burner off;
- 7 replace the photoresistor **FR** (Fig. 17) into its slot;
- 8 reconnect the **B** coil on the pump (Fig. 15);
- 9 light the burner; if the burner locks, press the unlock pushbutton, placed on the upper side of the burner and repeat the steps above.
- 10 ;when the flame lights up, press the **P1** pushbutton (see Fig. 16) for a while to fill the second nozzle pipe;

NOTE: The oil flow rate depends on the choosen nozzle. The air rate can be adjusted by means of the air damper actuator cams (see picture below).

- 11 The cam that enables the second stage solenoid valve to open (EVG2 valve) must be set between the other two cams;
- 12 drive the burner to **high flame** by means of the thermostat **TAB** (if **TAB** is not present, insert a bridge between T6 and T8 contacts on the related connector (see page 9)
- 13 adjust the high flame air flow rate acting on the related cam, in order to get the right combustion values.
- 14 drive the burner to **low flame** by means of the thermostat **TAB** (or remove the bridge between T6 and T8 contacts on the related connector (see page 9)
- 15 adjust the low flame air flow rate acting on the related cam, in order to get the right combustion values.
- 16 Replace the actuator and burner covers.

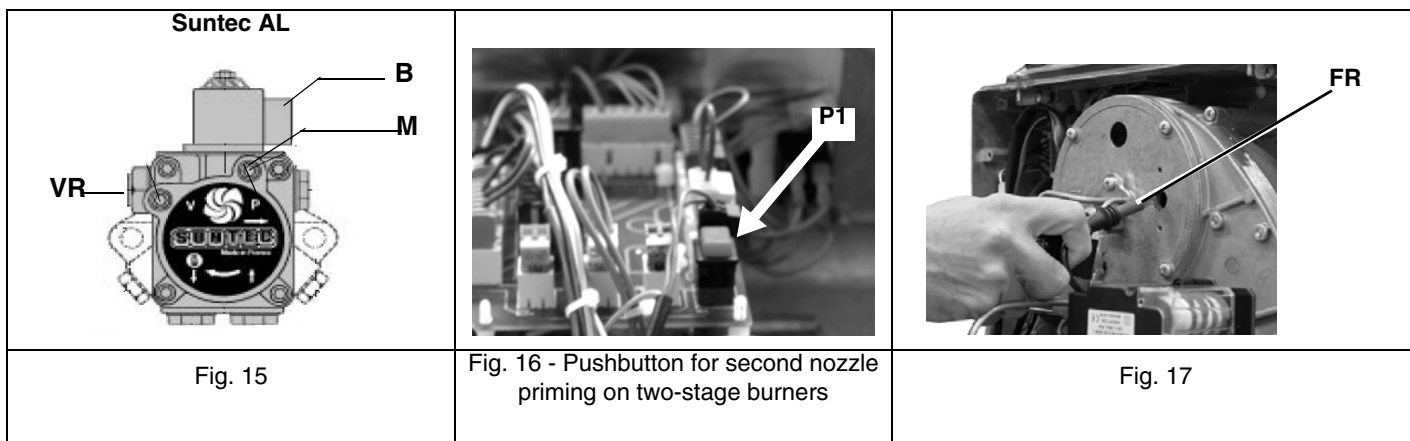

As for the setting, refer to this correspondence table.

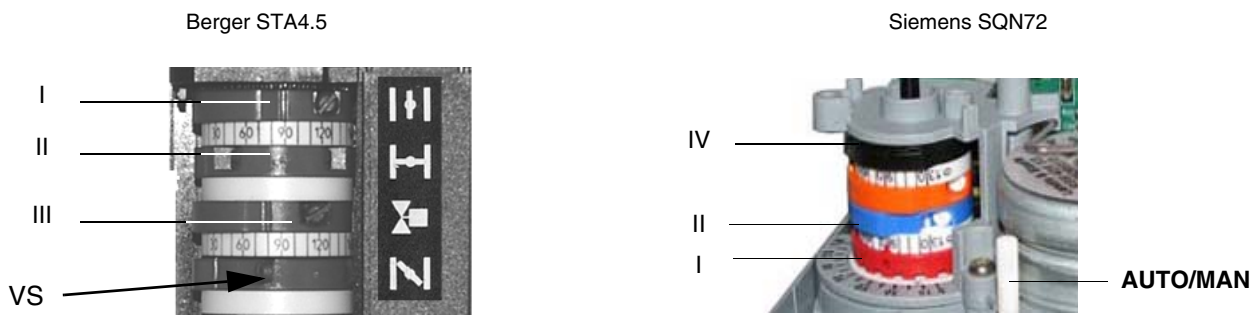

Refer to the next table for cams functions.

	BERGER STA	Siemens SQN72
"Air adjustment in high flame" cam	I	I (red)
Air adjustment in low flame - Stand-by - Ignition cam	II	II (blue)
Auxiliary cam for the opening consent to the second fuel valve	III	IV (black)

- Berger STA12: this actuator is not provided with the manual control of the air damper. The adjustment of the cams is carried out by means of a screwdriver, by twisting the **VS** screw located inside the cam.
- Siemens SQN72: a key is provided to move cams I and IV, the other cams can be moved by means of screws. On the Siemens actuator the AUTO/MAN mode is provided (see picture).

Adjusting the combustion head

The burner is set in the factory with the combustion head in the "MAX" position, corresponding to the maximum power (combustion head all-forward). To operate the burner at a lowest strenght, progressively shift back the combustion head, toward the "MIN" position, rotating the VRT screw clockwise (Fig. 18).

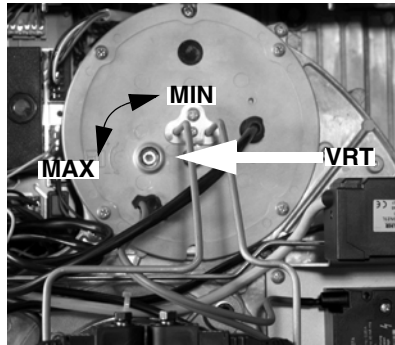

Fig. 18

Attention! if it is necessary to change the head position, repeat the air and gas adjustments described above.

PART II: OPERATION

LIMITATIONS OF USE

THE BURNER IS AN APPLIANCE DESIGNED AND CONSTRUCTED TO OPERATE ONLY AFTER BEING CORRECTLY CONNECTED TO A HEAT GENERATOR (E.G. BOILER, HOT AIR GENERATOR, FURNACE, ETC.), ANY OTHER USE IS TO BE CONSIDERED IMPROPER AND THEREFORE DANGEROUS.

THE USER MUST GUARANTEE THE CORRECT FITTING OF THE APPLIANCE, ENTRUSTING THE INSTALLATION OF IT TO QUALIFIED PERSONNEL AND HAVING THE FIRST COMMISSIONING OF IT CARRIED OUT BY A SERVICE CENTRE AUTHORIZED BY THE COMPANY MANUFACTURING THE BURNER.

A FUNDAMENTAL FACTOR IN THIS RESPECT IS THE ELECTRICAL CONNECTION TO THE GENERATOR'S CONTROL AND SAFETY UNITS (CONTROL THERMOSTAT, SAFETY, ETC.) WHICH GUARANTEES CORRECT AND SAFE FUNCTIONING OF THE BURNER.

THEREFORE, ANY OPERATION OF THE APPLIANCE MUST BE PREVENTED WHICH DEPARTS FROM THE INSTALLATION OPERATIONS OR WHICH HAPPENS AFTER TOTAL OR PARTIAL TAMPERING WITH THESE (E.G. DISCONNECTION, EVEN PARTIAL, OF THE ELECTRICAL LEADS, OPENING THE GENERATOR DOOR, DISMANTLING OF PART OF THE BURNER).

NEVER OPEN OR DISMANTLE ANY COMPONENT OF THE MACHINE.

OPERATE ONLY THE MAIN SWITCH, WHICH THROUGH ITS EASY ACCESSIBILITY AND RAPIDITY OF OPERATION ALSO FUNCTIONS AS AN EMERGENCY SWITCH, AND ON THE RESET BUTTON.

IN CASE OF A BURNER SHUT-DOWN, RESET THE CONTROL BOX BY MEANS OF THE RESET PUSHBUTTON. IF A SECOND SHUT-DOWN TAKES PLACE, CALL THE TECHNICAL SERVICE, WITHOUT TRYING TO RESET FURTHER.

WARNING: DURING NORMAL OPERATION THE PARTS OF THE BURNER NEAREST TO THE GENERATOR (COUPLING FLANGE) CAN BECOME VERY HOT, AVOID TOUCHING THEM SO AS NOT TO GET BURNT.

OPERATION

	<p>ATTENTION: before starting the burner up, be sure that the manual cutoff valves are open and check that the pressure upstream the gas train complies the value quoted on paragraph "Technical specifications".</p> <p>ATTENTION: READ CAREFULLY THE "WARNINGS" CHAPTER AT THE BEGINNING OF THIS MANUAL..</p>
---	---

Single stage burners

- Set Switch E on the burner control panel to ON position.
- Make sure that the control box is not in shutdown condition; if so, release by means of the release button (F in Fig. 19) on the burner control panel.
- Make sure that the set of thermostats (or pressure-switches) enables burner operation.
- The burner starting cycle begins and the control box starts the burner fan while the ignition transformer switches on at the same time.
- At the end of pre-purge, the fuel solenoid valve is energised and the burner switches on.
- The ignition transformer is on for a few seconds after the ignition of the flame (post-ignition time) after which it is de-energised.

Double stage burners

- Set Switch G on the burner control panel in ON position.
- Make sure that the control box is not in shutdown condition; if so, release by using the release button (F in Fig. 19 and H in) on the burner control panel.
- Make sure that the set of thermostats (or pressure-switches) enables burner operation.
- The burner starting cycle begins and the control box starts the burner fan while the ignition transformer switches on at the same time; pre-purge lasts for some seconds depending on the control box provided with the burner.
- At the end of pre-purge, the fuel solenoid valve (1st stage, EVG1) is energised as signalled (signal light on the control panel is on) and the burner starts up.
- The ignition transformer remains switched on for a few seconds after the ignition of the flame (post-ignition time), after which it is de-energised and the related signal light switches off.
- In this way, the burner is lit at low flame; after some seconds (depending on the control box installed) two-stage operation begins and the burner is either automatically driven to high flame or remains burning at low flame depending on the requests received from the system. Operation at high or low flame is signalled by the switching on/off of the related signalling lights A and F on the

control panel; signalling light F shows the opening of the solenoid valve that supplies the 2nd stage nozzle (high flame).

Burner control panel

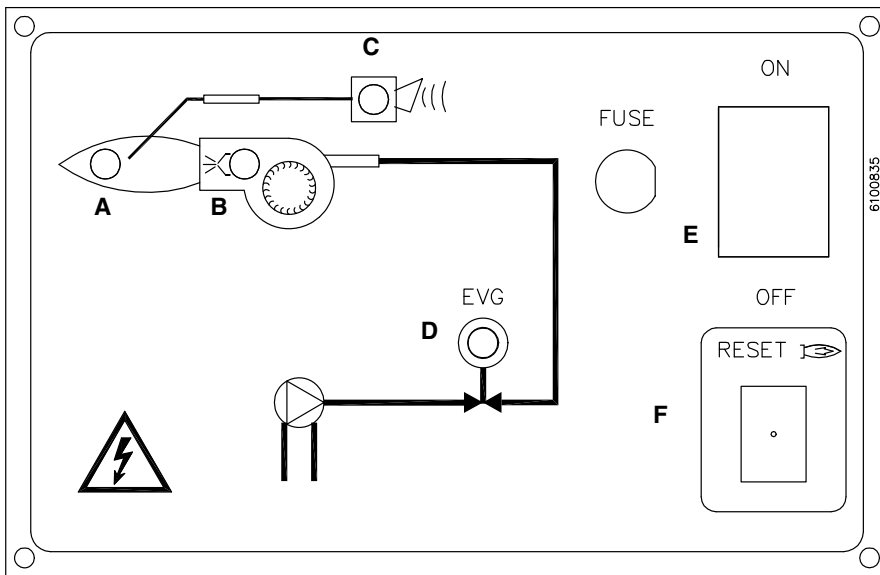

Keys

- A Burner operation signalling lamp
- B Ignition transformer operation signalling light
- C Lockout signalling lamp
- D Light oil solenoid valve operation signalling light
- E Mains switch
- F Reset pushbutton for flame control box

Fig. 19 - Single stage burner

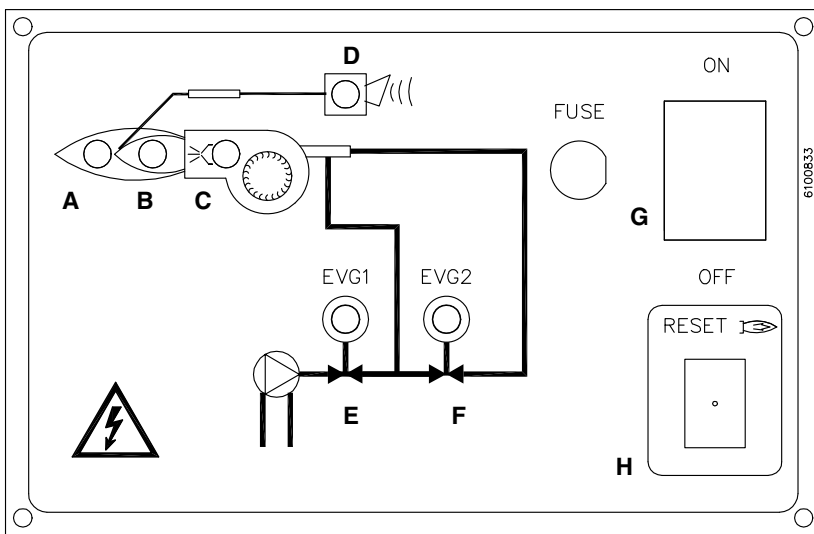

Key

- A High flame operation signalling light
- B Low flame operation light
- C Ignition transformer operation signalling light
- D Lockout signalling lamp
- E Low flame solenoid valve operation signalling light
- F High flame solenoid valve operation signalling light
- G Mains switch
- H Reset pushbutton for flame control box

Fig. 20 - Double stage burner

PART III: MAINTENANCE

At least once a year carry out the maintenance operations listed below. In the case of seasonal servicing, it is recommended to carry out the maintenance at the end of each heating season; in the case of continuous operation the maintenance is carried out every 6 months.



WARNING: ALL OPERATIONS ON THE BURNER MUST BE CARRIED OUT WITH THE MAINS DISCONNECTED AND THE FUEL MANUAL CUTOFF VALVES CLOSED!

ATTENTION: READ CAREFULLY THE "WARNINGS" CHAPTER AT THE BEGINNING OF THIS MANUAL..

ROUTINE MAINTENANCE

- Inspection and cleaning of the light oil filter cartridge; replace it if necessary;
- Check the overall condition of the flexible light oil hoses and make sure there are no signs of leakage;
- check and clean the filter on the fuel pump: filter must be thoroughly cleaned at least once in a season to ensure correct working of the fuel unit. To remove the filter, unscrew the four screws on the cover. When reassemble, make sure that the filter is mounted with the feet toward the pump body. If the gasket between cover and pump housing should be damaged, it must be replaced;
- disassemble, check and clean of the combustion head. When re-assembling carefully observe the measures quoted in Fig. 35;
- check and clean the ignition electrodes and respective ceramic insulators: clean, adjust, and replace if necessary;
- Disassemble and clean the light oil nozzles.



IMPORTANT: cleaning must be performed using solvent, not metal tools!

At the end of maintenance operations after first reassembling the burner, light the flame and check its shape, replacing the nozzle whenever a questionable flame shape appears. Whenever the burner is used intensely, we recommend preventively replacing the nozzle at the start of each heating season;

- Inspect and thoroughly clean the flame detection photoresistor and replace if necessary. In case of doubt, check the detection current after first starting the burner by following the procedure illustrated in Fig. 36;
- Clean and grease levers and rotating parts.

Light oil filter maintenance

For correct and proper servicing, proceed as follows:

- 1 shut off fuel in the line section being serviced;
- 2 unscrew the tray;
- 3 remove the filter cartridge from its support and wash it with petrol or replace if necessary; check seal O-Ring, replace if necessary;
- 4 reassemble the tray and restore fuel flow.



Removing the combustion head and the oil gun

- Slacken the light oil pipes T1 and T2 from the pump (Fig. 21).
- Disconnect the ignition cables CA1 and CA2 from the transformer (Fig. 22).
- Remove the 4 screws V1 - V4 shown in Fig. 23.

⚠ ATTENTION: the screw V1 is longer than the other and must be replaced in the same position!

- Withdraw the photoelectric cell FR from its housing (Fig. 24).

⚠ ATTENTION: avoid to withdraw the photoelectric cell drawing its cable!

- Remove the combustion head from its housing as shown in Fig. 25.

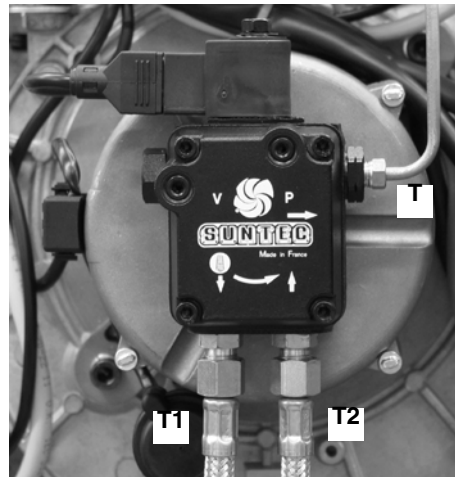

Fig. 21

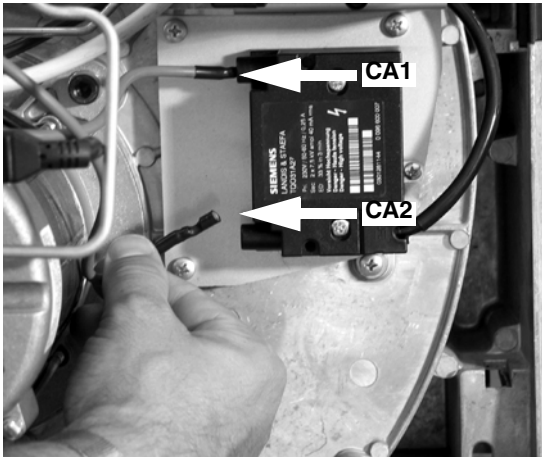

Fig. 22

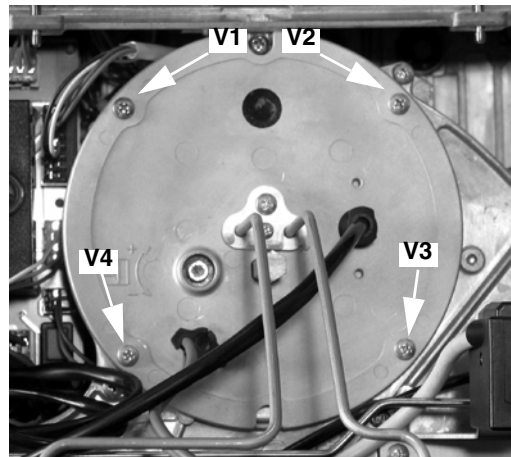

Fig. 23

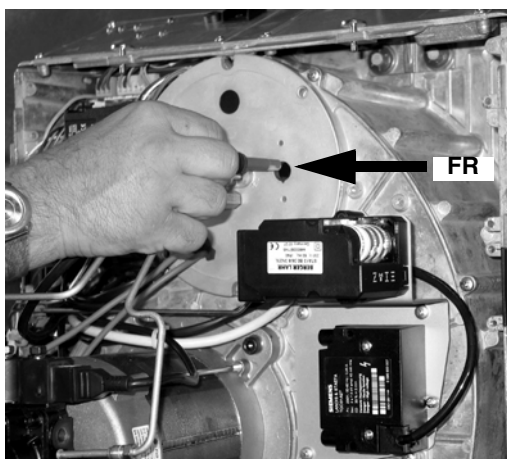

Fig. 24

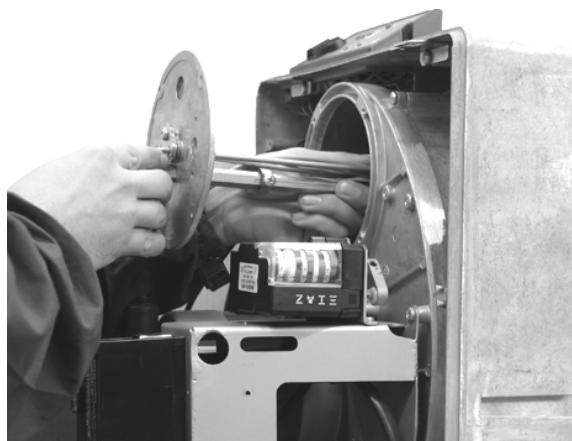

Fig. 25

Removing burner components plate

- Remove the combustion head (see page 20).
- Remove the 6 screws V5 - V10 which fasten the component plate (Fig. 26).
- Remove the rod T from its housing as shown in Fig. 27.
- Hook the burner components plate as shown in Fig. 28.

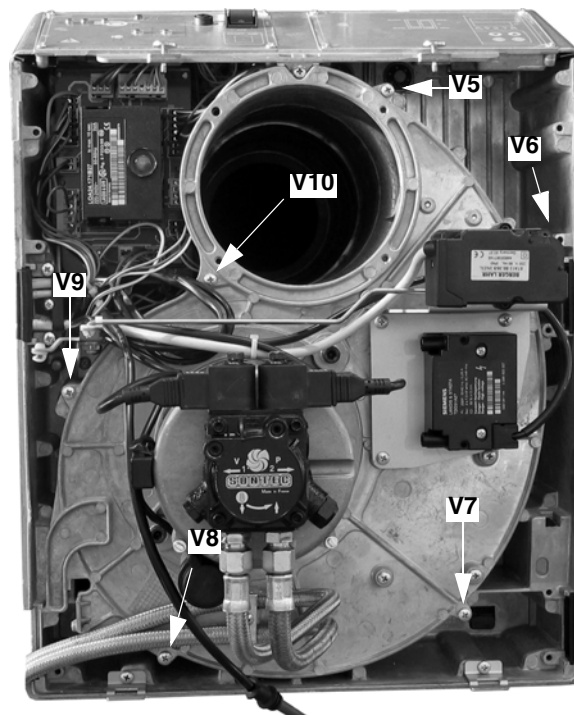

Fig. 26

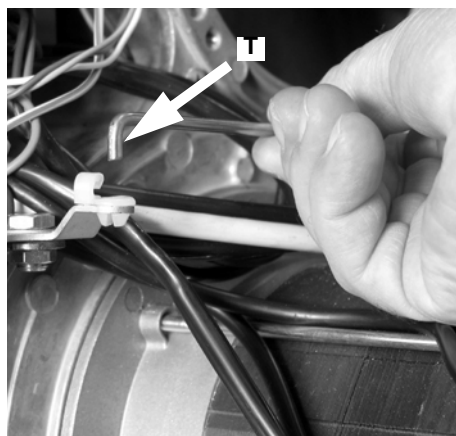

Fig. 27

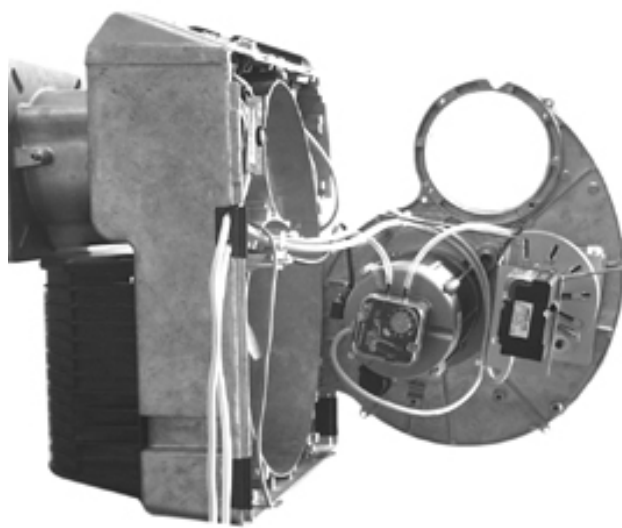

Fig. 28

Replacing burner components plate

- Reassemble burner components plate and tighten the 6 screws V5 - V10 (Fig. 26).
- Refit the rod T (Fig. 27).
- Reassemble the combustion head and tighten the 4 screws V1 - V4 (Fig. 28).

Removing the electrodes

- Remove the combustion head (page 20).
- Withdraw the screw VE and remove the electrodes from the support (Fig. 29 - Fig. 30).

Single stage burners

Double stage burners

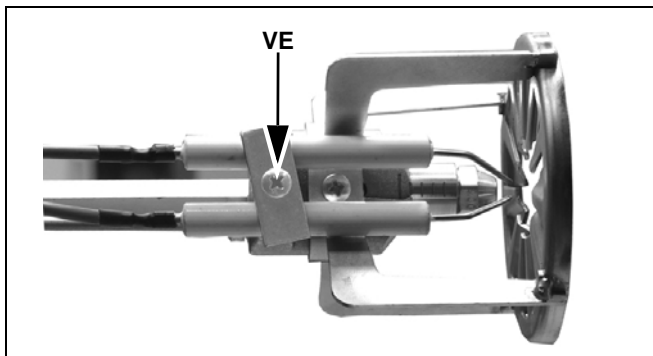

Fig. 29

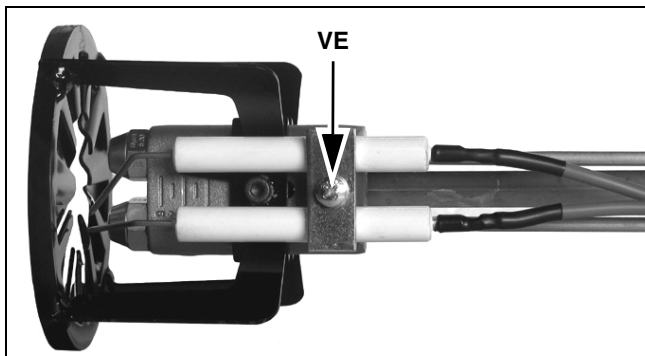

Fig. 30

Removing the nozzles

- Unscrew the Allen screw VT and remove the combustion head TC.
- Unscrew the nozzles using two wrenches (16 and 24 mm), as shown in Fig. 31 - Fig. 32.

Single stage burners

Double stage burners

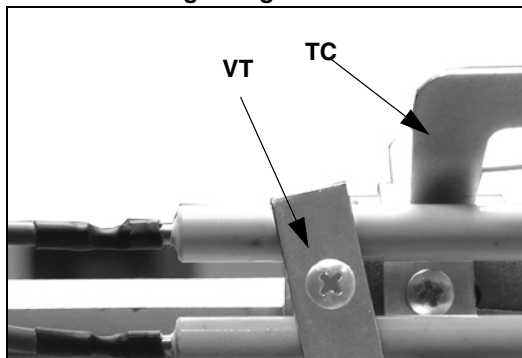

Fig. 31

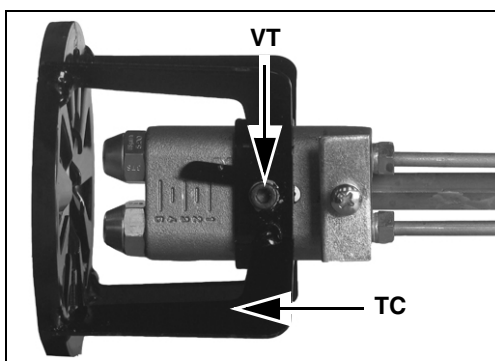

Fig. 32

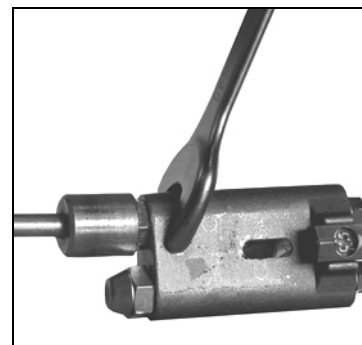



Fig. 33

Correct position of electrodes and combustion head

	<p>ATTENTION: avoid the electrodes to get in touch with metallic parts (blast tube, head, etc.), otherwise the boiler operation would be compromised. Check the electrodes position after any intervention on the combustion head.</p>
---	---

To ensure a good ignition, respect the measures (in mm) in Fig. 34 - Fig. 35.

Single stage burners

- A 7 ÷ 9
- B 4,5 ÷ 6
- C 10
- D 5

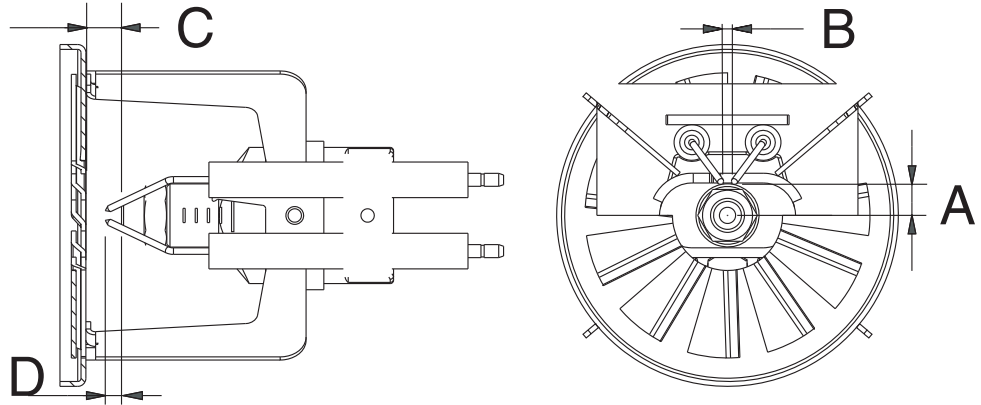

Fig. 34

High-Low flame burners

- A 9 ÷ 11
- B 4,5 ÷ 6
- C 8
- D 3

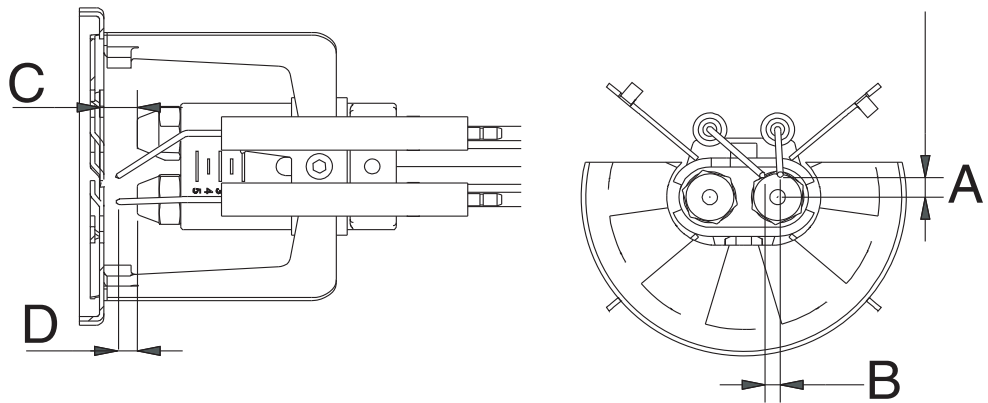

Fig. 35

Checking the detection current

To measure the detection signal follow the diagram on the next picture.

If the signal is not in the advised range, check the electrical contacts, the cleaning of the combustion head, the position of the photoreistor and if necessary replace it.

Minimum current intensity with flame	65 μ A
Maximum current intensity without flame	5 μ A
Maximum possible current intensity with flame	200 μ A

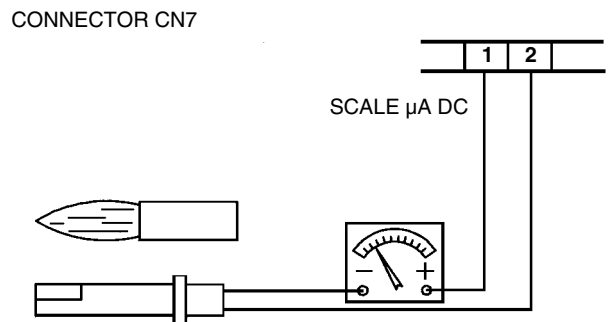

Fig. 36

Cleaning and replacing the detection photoresistor

To clean/replace the photoresistor, proceed as follows:

- 1 disconnect the system from the electrical power supply;
- 2 shut off the fuel supply;
- 3 remove the photoresistor from its slot;
- 4 clean it using a clean cloth; do not use any burner cleansing sprays;
- 5 if necessary, replace it;
- 6 insert the photoresistor into its slot.

Burner control panel disassembly

⚠ IMPORTANT: perform operations on the burner's electrical components only after first disconnecting the apparatus from the mains!

- 1 Remove the VQ screw that fastens the control panel to the burner head support (Fig. 37).
- 2 Remove the VF1 and VF3 screws from the rubber cable gland; the cables will remain in place because they are locked by the retainer fastened by the VF2 screw (Fig. 37).
- 3 Remove the rubber and cable gland unit FC from the housing (Fig. 38).
- 4 Connect the control panel to the burner body using the supports G provided as shown in Fig. 39.

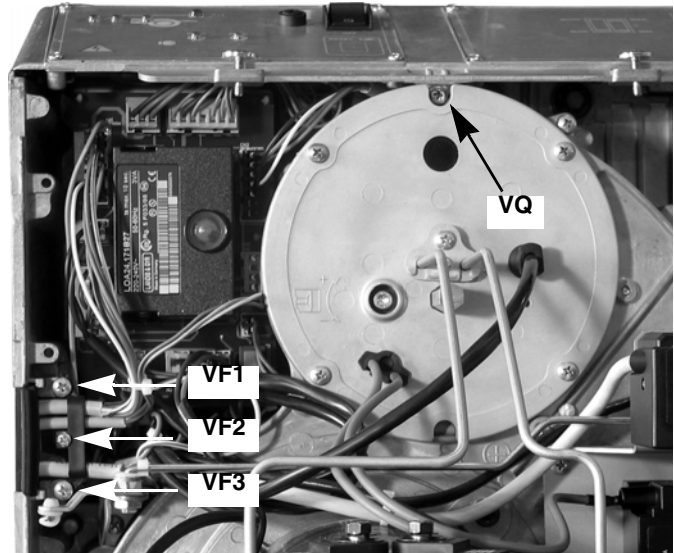

Fig. 37

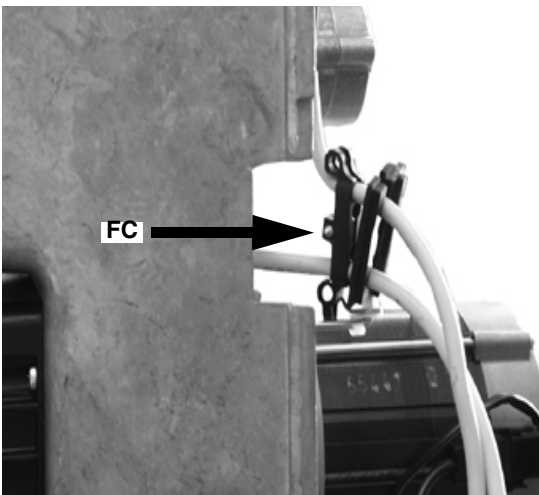

Fig. 38

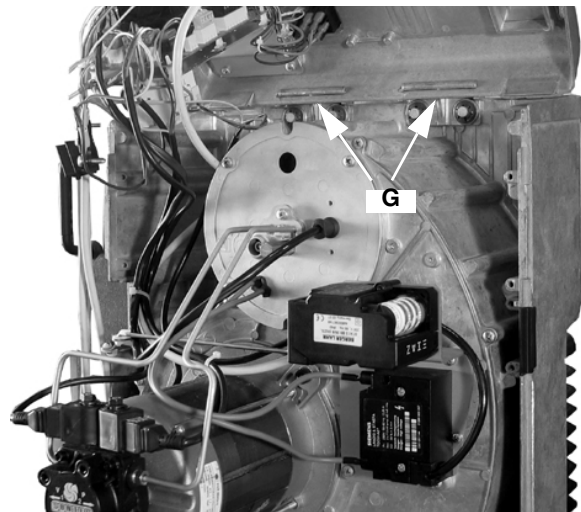

Fig. 39

Seasonal stop

To stop the burner in the seasonal stop, proceed as follows:

- 1 turn the burner's main switch to 0 (Off position)
- 2 disconnect the power mains
- 3 close the fuel manual valve of the supply line

Burner disposal

In case of disposal, follow the instructions according to the laws in force in your country about the "Disposal of materials".

TROUBLESHOOTING

	BURNER DOESN'T START	REPETITION OF PRE-PURGE	NOISY FUEL PUMP	BURNER DOESN'T START AND LOCKS	BURNER STARTS AND LOCKS	BURNER DOESN'T SWITCH TO HIGH FLAME	BURNER LOCK DURING OPERATION	BURNER LOCKS AND REPEATS CYCLE DURING OPERATION
MAINS SWITCH OPEN	●							
FUSES INTERVENTION	●							
MAXIMUM PRESSURE SWITCH FAULT	●							●
INTERVENTION OF THE FAN MOTOR THERMAL CUTOUT	●							
AUXILIARIES RELAY FUSES INTERVENTION	●							
FLAME CONTROL DEVICE FAULT	●	●		●	●		●	
SERVOCONTROL FAULT						●		
SMOKY FLAME					●		●	
IGNITION TRANSFORMER FAULT				●				
IGNITION ELECTRODE DIRTY OR BAD POSITION				●				
DIRTY NOZZLE				●				
FUEL SOLENOID VALVE DEFECTIVE				●			●	
PHORESISTANCE DIRTY OR DEFECTIVE					●		●	
HIGH - LOW FLAME THERMOSTAT DEFECTIVE						●		
BAD POSITION OF SERVOCONTROL CAMS						●		
FUEL LOW PRESSURE				●				
FUEL FILTERS DIRTY			●	●			●	

BURNER EXPLODED VIEW

ITEM	DESCRIPTION
1	BLAST TUBE
2	PUMP
3	COVER FIXING SCREW
4	AIR DAMPER ASSEMBLY
5	AIR INTAKE
6	PRESSURE PLUG
7	BRACKET
8	COVER
9	FAIRLEAD
10	PIPE
11	BURNER HOUSING
12	MOTOR SUPPORT PLATE
13	BURNER HOUSING HINGE
14	PLATE
15	FLANGE GASKET
16	FAN WHEEL
17	MOTOR
18	AIR FLAP
19	WASHER
20	WASHER
21	SCREW
22	CONNECTING ROD
23	ROD
24	BRACKET
25	TRANSFORMER
26	ACTUATOR

ITEM	DESCRIPTION
27	BRACKET
28	BRACKET
29	PANEL
30	EARTH PLATE
31	PRINTED BOARD CIRCUIT
32	CONTACTOR
33	PUSHBUTTON PROTECTION
34	SWITCH
35	FUSE
36	CONTROL BOX + SOCKET
37	FLANGE
38	SHORT IGNITION ELECTRODE
39	LONG IGNITION ELECTRODE
40	SOLENOID VALVE
41	PLATE
42	PLATE
43	ROD
44	NOZZLE
45	NOZZLE
46	NOZZLE HOLDER
47	UNIT FOR PIPE CONNECTION
48	COMBUSTION HEAD
49	PIPE
50	PIPE
51	PIPE
52	IGNITION CABLE

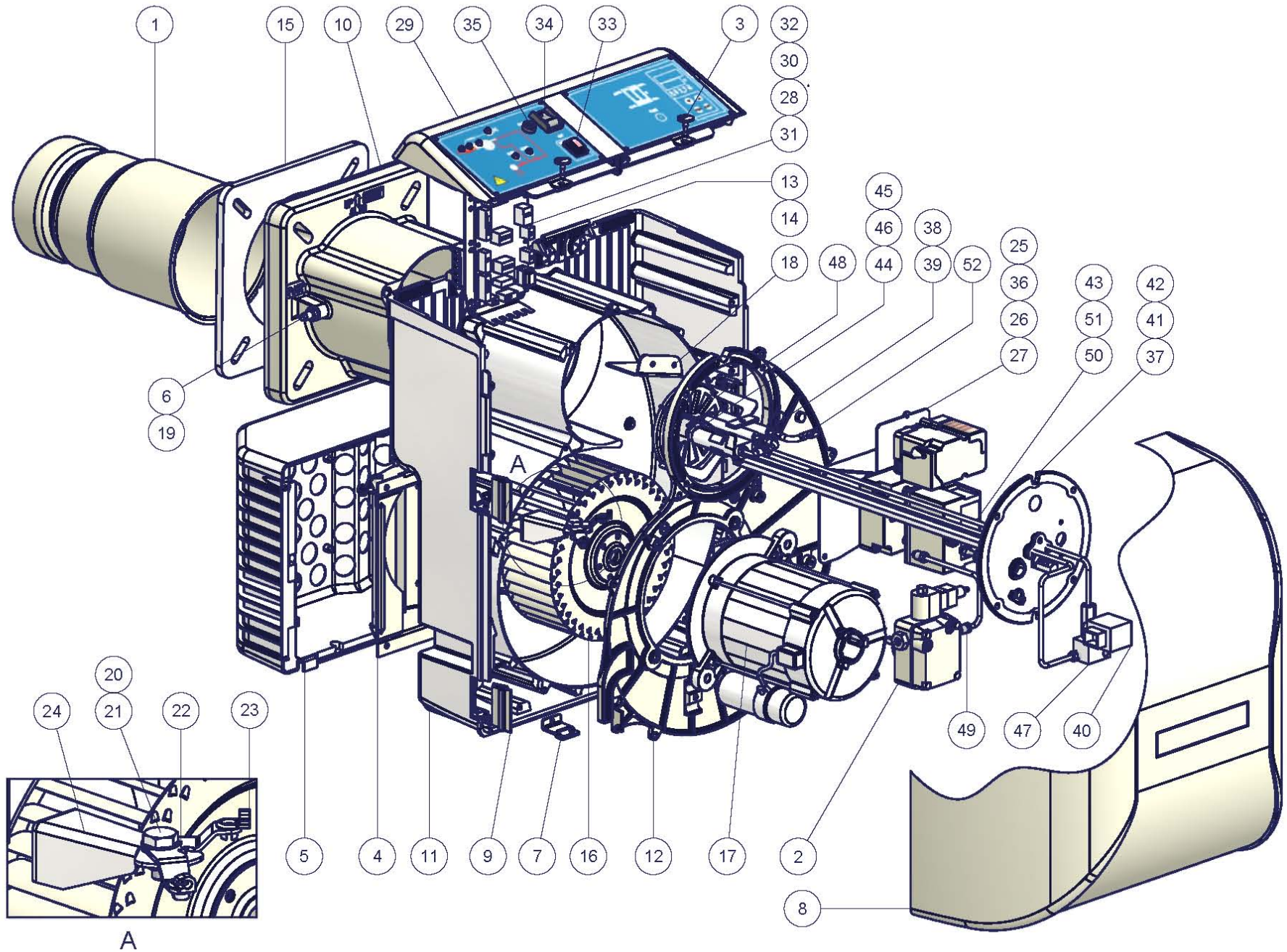

SPARE PARTS

Description	Code	
	LO550 TN	LO550 AB
COVER	1011801	1011801
CONTROL BOX (SIEMENS LOA..)	2020445	2020445
CONTROL BOX (SIEMENS LMO..)	2020453	2020453
SHORT IGNITION ELECTRODE	2080259	2080259
LONG IGNITION ELECTRODE	-	2080260
FUEL FILTER	2090025	2090025
GASKET	2110056	2110056
FAN WHEEL	2150049	2150049
IGNITION TRANSFORMER (FIDA)	2170302	-
IGNITION TRANSFORMER (COFI)	-	2170139
IGNITION TRANSFORMER (DANFOSS)	-	2170231
ELECTRIC MOTOR	2180711	2180711
SOLENOID VALVE	-	2190638
FLEXIBLE HOSE	2340001	2340001
ACTUATOR (mod. BERGER)	-	2480057
ACTUATOR (mod. SIEMENS)	-	24800A3
PHOTORESISTOR (mod. SIEMENS QRB..)	2510033	2510033
PUMP (mod. SUNTEC)	2590170	2590170
NOZZLE - 0.75-6.00GPH 45°	-	2610002
NOZZLE - 0.75-6.00GPH 60°	2610004	2610004
NOZZLE - 6.50-11.00GPH 60°	2610017	-
NOZZLE - 6.50-35.00 GPH 45°	-	2610016
COMBUSTION HEAD	3060199	3060198
BLAST TUBE (standard)	30900F5	30900F5
BLAST TUBE (extended)	30900F6	30900F6
IGNITION CABLES	6050153	6050153
PRINTED CIRCUIT BOARD	6100542	6100542

WIRING DIAGRAMS**Keys**

C1	LOW FLAME TIME METER
C2	HIGH FLAME TIME METER
EVG	LIGHT OIL ELECTRO-VALVE
FR	PHOTORESISTOR FLAME DETECTOR
FU1	FAN MOTOR LINE FUSE
FU2	LINE FUSE
FU3	BURNER LINE FUSE
IL	BURNER LINE SWITCH
IM	FAN MOTOR LINE SWITCH
KA2.3	AUXILIARY RELAY
KA2.4	AUXILIARY RELAY
KM1.1	FAN MOTOR CONTACTOR
KT2.4	DELAYED RELAY
LAF	BURNER IN HIGH FLAME INDICATOR LIGHT
LMO 24/44	SIEMENS CONTROL BOX
LOA24/44	SIEMENS CONTROL BOX
LB	INDICATOR LIGHT FOR BURNER LOCK-OUT
LBF	BURNER IN LOW FLAME INDICATOR LIGHT
LEVg1	INDICATOR LIGHT FOR OPENING OF ELECTRO-VALVE [EVG1]
LTA	IGNITION TRANSFORMER INDICATOR LIGHT
MV	FAN MOTOR
PS	LOCK-OUT RESET BUTTON (WITH LOA44 AND LMO.. ONLY)
SATRONIC DKO976 -	DKW976CONTROL BOX
SATRONIC DKW972	CONTROL BOX
SATRONIC TF976	CONTROL BOX
ST	SERIES OF THERMOSTATS OR PRESSURE SWITCHES
SW1	II° STAGE BURNER START BUTTON
TA	IGNITION TRANSFORMER
TAB	HIGH-LOW THERMOSTAT/PRESSURE SWITCHES
TS	SAFETY THERMOSTAT OR PRESSURE SWITCH

(\$) IF "TAB" USED REMOVE THE BRIDGE BETWEEN TERMINALS T6-T8

WARNING

- 1 - Electrical supply 230V 50/60Hz 1N a.c.
- 2 - Do not reverse phase with neutral
- 3 - Ensure burner is properly earthed

VERSIONE MONOSTADIO "TN"
"TN" SINGLE-STAGE VERSION

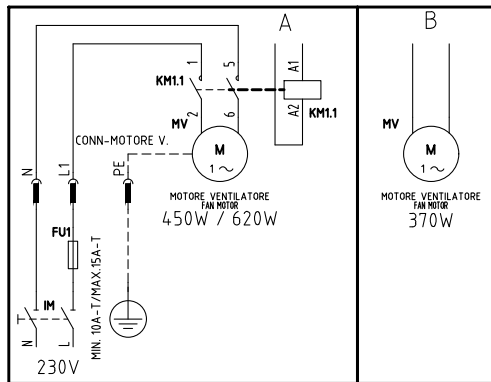
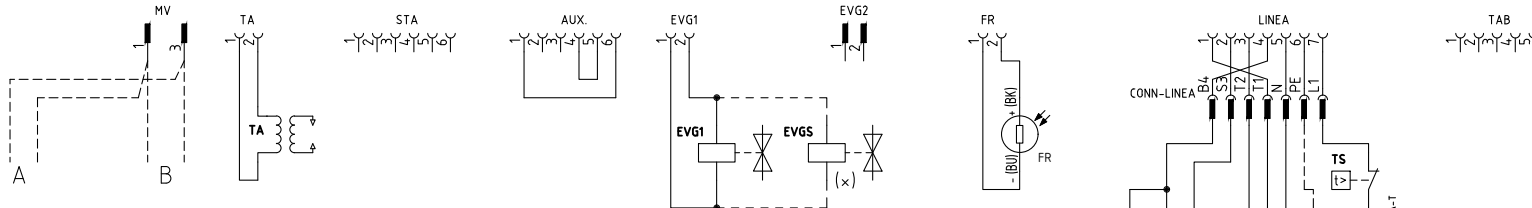
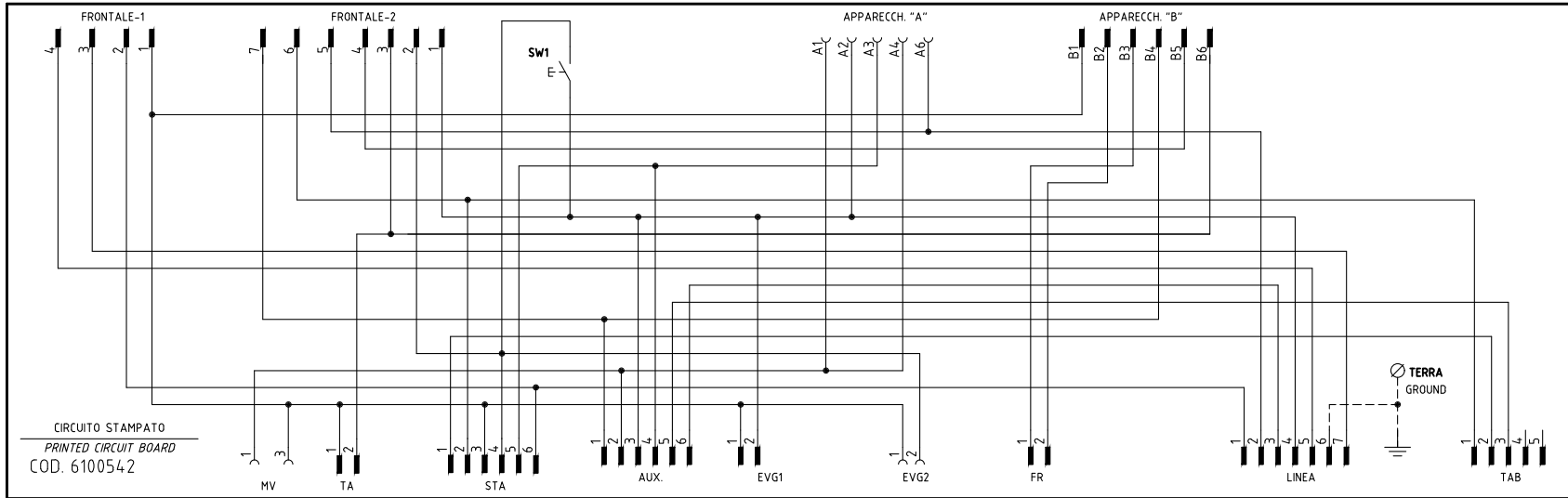
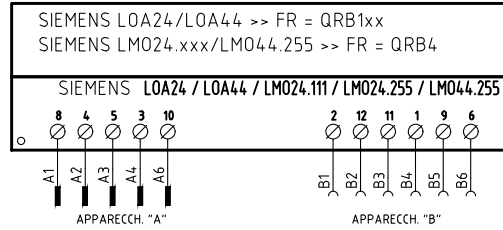
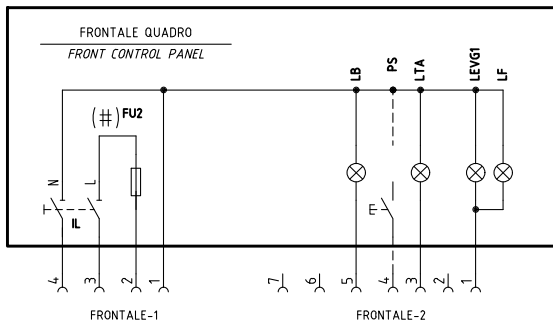

(x) EVGS = SOLO CON POTENZA > 400kW
EVGS = ONLY WITH OUTPUT > 400kW

(#) MOTORE VENTIL. 450W O 620W, FU2 = 6,3A F; MOTORE VENTIL. 370W, FU2 = 10A F
FAN MOTOR 450W OR 620W, FU2 = 6,3A F; FAN MOTOR 370W FU2 = 10A F

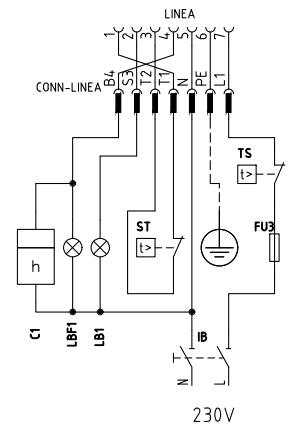

Data	13/10/2004	PREC.	FOGLIO
Revisione	06	/	1
Dis. N.	18 - 0049	SEGUE	TOTALE
		2	3

VERSIONE ALTA-BASSA FIAMMA "AB"
"AB" HIGH/LOW FLAME VERSION

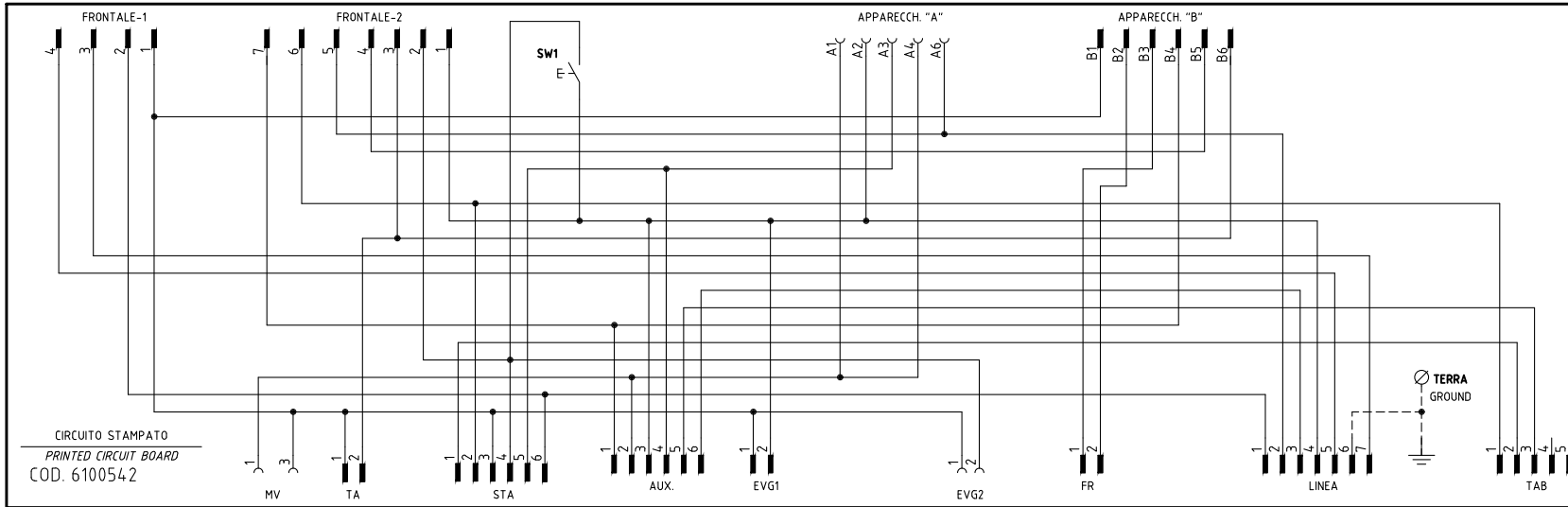
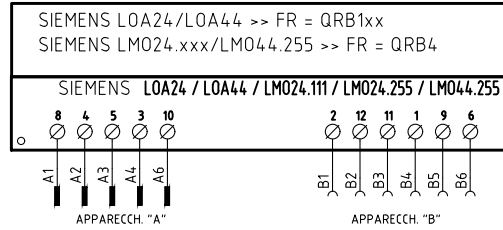
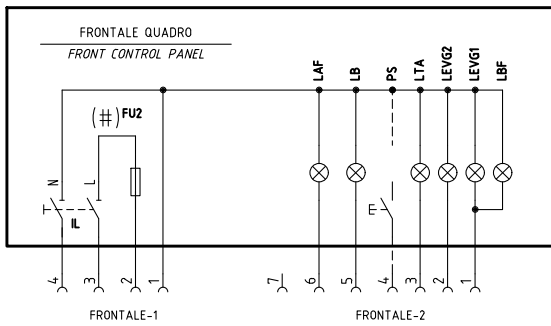

SERVOCOMANDO SERRANDA ARIA
AIR DAMPER ACTUATOR
STA4.5B0.37/63N30L

- I ALTA FIAMMA
HIGH FLAME
- II SOSTA - ACCENSIONE, BASSA FIAMMA
STAND-BY; IGNITION, LOW FLAME
- III APERTURA - EVG2
OPEN EVG2

SERVOCOMANDO SERRANDA ARIA (ALTERNATIVO)
AIR DAMPER ACTUATOR (ALTERNATIVE)
SQN72.2A4A20

- I (ROSSO) ALTA FIAMMA
I (RED) HIGH FLAME
- II (BLU) SOSTA - ACCENSIONE, BASSA FIAMMA
II (BLUE) STAND-BY; IGNITION, LOW FLAME
- IV (NERO) APERTURA EVG2
IV (BLACK) OPEN EVG2

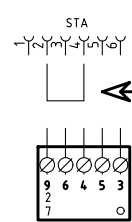
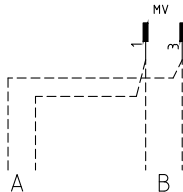

STA4.5B0.37/63N30L

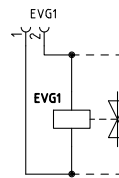
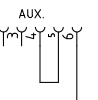
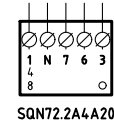

(x) EVGS = SOLO CON POTENZA > 400kW
EVGS = ONLY WITH OUTPUT > 400kW

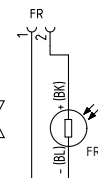
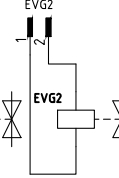

VERSIONE CON MARTINETTO IDRAULICO
WITH HYDRAULIC RAM VERSION

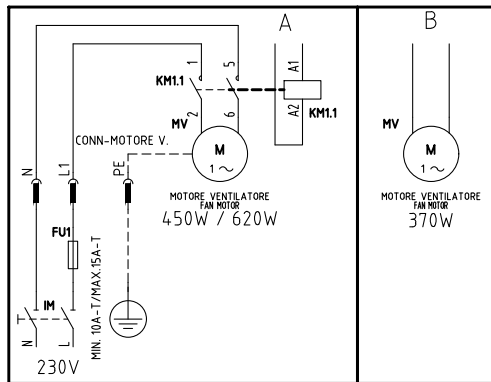
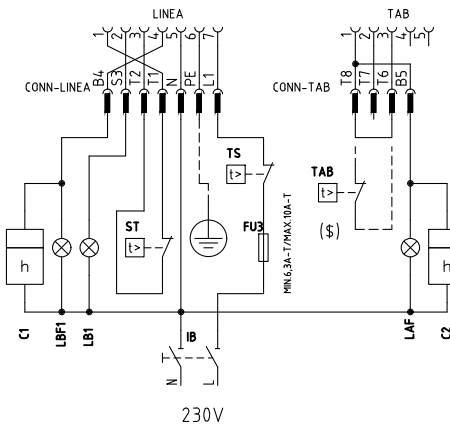

- (#) MOTORE VENTIL. 450W O 620W, FU2 = 6,3A F; MOTORE VENTIL. 370W, FU2 = 10A F
FAN MOTOR 450W OR 620W, FU2 = 6,3A F; FAN MOTOR 370W FU2 = 10A F
- (\$)
- SE USATO "TAB", TOGLIERE IL PONTE TRA I MORSETTI [T6-T8]
IF USED "TAB", REMOVE THE BRIDGE BETWEEN TERMINALS [T6-T8]

Data	13/10/2004	PREC.	FOGLIO
Revisione	06	1	2
Dis. N.	18 - 0049	SEQUE	TOTALE
		3	3

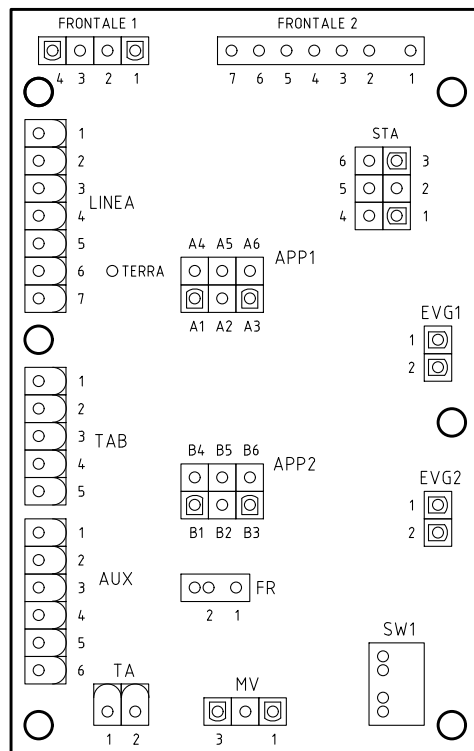

Sigla/Item	Funzione	Function
C1	CONTAORE BASSA FIAMMA	LOW FLAME TIME COUNTER
C2	CONTAORE ALTA FIAMMA	HIGH FLAME TIME COUNTER
EVG1	ELETTROVALVOLA GASOLIO BASSA FIAMMA	LOW FLAME LIGHT OIL SOLENOID VALVE
EVG2	ELETTROVALVOLA GASOLIO ALTA FIAMMA	HIGH FLAME LIGHT OIL SOLENOID VALVE
EVGS	ELETTROVALVOLA GASOLIO DI SICUREZZA	SAFETY LIGHT OIL SOLENOID VALVE
FR	SONDA RILEVAZIONE FIAMMA	FLAME DETECTOR PROBE
FU1	FUSIBILE LINEA MOTORE VENTILATORE	FAN MOTOR LINE FUSE
FU2	FUSIBILE DI LINEA	LINE FUSE
FU3	FUSIBILE LINEA BRUCIATORE	BURNER LINE FUSE
IB	INTERRUTTORE LINEA BRUCIATORE	BURNER LINE SWITCH
IL	INTERRUTTORE LINEA AUSILIARI	AUXILIARY LINE SWITCH
IM	INTERRUTTORE LINEA MOTORE VENTILATORE	FAN MOTOR LINE SWITCH
KM1.1	CONTATTORE MOTORE VENTILATORE	FAN MOTOR CONTACTOR
LAF	LAMPADA SEGNALAZIONE ALTA FIAMMA BRUCIATORE	BURNER IN HIGH FLAME INDICATOR LIGHT
LB	LAMPADA SEGNALAZIONE BLOCCO BRUCIATORE	INDICATOR LIGHT FOR BURNER LOCK-OUT
LB1	LAMPADA SEGNALAZIONE BLOCCO BRUCIATORE	INDICATOR LIGHT FOR BURNER LOCK-OUT
LBF	LAMPADA SEGNALAZIONE BASSA FIAMMA BRUCIATORE	BURNER IN LOW FLAME INDICATOR LIGHT
LBF1	LAMPADA SEGNALAZIONE BASSA FIAMMA BRUCIATORE	BURNER IN LOW FLAME INDICATOR LIGHT
LEVG1	LAMPADA SEGNALAZIONE APERTURA [EVG1]	INDICATOR LIGHT FOR OPENING OF ELECTRO-VALVE [EVG1]
LEVG2	LAMPADA SEGNALAZIONE APERTURA [EVG2]	INDICATOR LIGHT FOR OPENING OF ELECTRO-VALVE [EVG2]
LF	LAMPADA SEGNALAZIONE FUNZIONAMENTO BRUCIATORE	INDICATOR LIGHT BURNER OPERATION
LOA... / LMO...	APPARECCHIATURA CONTROLLO FIAMMA	CONTROL BOX
LTA	LAMPADA SEGNALAZIONE TRASFORMATORE DI ACCENSIONE	IGNITION TRANSFORMER INDICATOR LIGHT
MV	MOTORE VENTILATORE	FAN MOTOR
PS	PULSANTE SBLOCCO FIAMMA (SOLO CON LOA44 E LMO.)	LOCK-OUT RESET BUTTON (WITH LOA44 AND LMO. ONLY)
SQN72.2A4A20	SERVOCOMANDO SERRANDA ARIA (ALTERNATIVO)	AIR DAMPER ACTUATOR (ALTERNATIVE)
ST	SERIE TERMOSTATI/PRESSOSTATI	SERIES OF THERMOSTATS OR PRESSURE SWITCHES
STA4.5B0.37/63N30L	SERVOCOMANDO SERRANDA ARIA	AIR DAMPER ACTUATOR
SW1	PULSANTE INNESCO SECONDO STADIO BRUCIATORE	II° STAGE BURNER START BUTTON
TA	TRASFORMATORE DI ACCENSIONE	IGNITION TRANSFORMER
TAB	TERMOSTATO/PRESSOSTATO ALTA-BASSA FIAMMA	HIGH-LOW THERMOSTAT/PRESSURE SWITCHES
TS	TERMOSTATO/PRESSOSTATO DI SICUREZZA	SAFETY THERMOSTAT OR PRESSURE SWITCH

Data	13/10/2004	PREC.	FOGLIO
Revisione	06	2	3
Dis. N.	18 - 0049	SEGUE	TOTALE
		/	3

APPENDIX

SIEMENS OIL BURNERS AUTOMATIC CONTROLLER LOA24

Use

LOA... safety devices are intended for use solely with QRB... photoresistors, for lighting and controlling low capacity forced air light oil burners with max. capacity 30 kg/h in accordance with standard DIN 4787.

The One or two flames are lit through electrical connections with or without post-ignition.

To replace LAI... AND LAB.. WITH LOA...

LOA... models can be used as replacement for LAI... and LAB.. controllers by means of the adapter KF8819 and without the need to change the electrical wiring. Because the LOA is smaller in dimensions, when it is used with the adapter the external dimensions are almost identical, which means that there is no need to move the reset button.

Performance

The controllers just need plugging in, so they can be mounted in almost any position: on the burner, on the electrical panel or on the control panel. The casing is made of robust heat-resistant plastic and contains:

- the thermic programmer operating a multiple switch control system with ambient temperature compensator
- flame signal amplifier with flame relay
- warning light indicating lockout and associated sealed reset button.

The plug-in socket, also made of robust heat-resistant plastic, contains the 12 terminals and also:

- 3 neutral terminals, ready wired up to terminal 2
- 4 earth terminals for earthing the burner
- 2 supplementary terminals numbered "31" and "32".

The socket has two openings at the bottom for the leads; 5 others with threaded connection for cable holders PG11 or 3/4UNP for non-metallic sleeves are located on a mobile stuffing box, one on either side and 3 on the front.

There are two flexible metal tongues on the sides of the socket for mounting.

To dismantle it only requires gentle pressure with a screw driver in the slot of the mounting guide. The base dimensions of the socket are exactly the same as for types LAB/LAI and there is no difference in the diameter of the reset button, the two mounting screws and the flange of the burner earth.

Safety at low voltage levels

Safety devices against any reduction in the mains voltage operate on a special electronic circuit which, in the event of the power supply falling below 165V~, stops the burner switching on without releasing the fuel and locks out the apparatus.

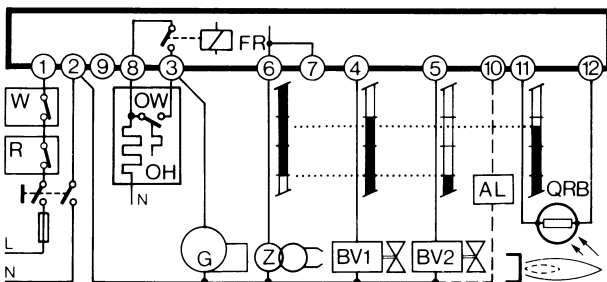

Wiring diagram of the programme

To ensure correct wiring it is essential to observe local standards and follow the instructions of the burner manufacturer with regard to assembly and start-up.

Program's legend:

- Controller output signals
- ▤ Required input signals

- A' Burner start up with light oil pre-heater OH
- A Burner start-up without light oil pre-heater
- B Flame lit
- C Normal operation
- D Normal stop through R
- tw Oil pre-heating time until operational all clear given through contact OW
- t1 Pre-purge time
- t3 Pre-ignition time
- t2 Safety time
- t3n Post-ignition time
- t4 Interval between the flame lighting and energising of solenoid 2a at terminal 5

Internal layout

- AL Optical alarm
- BV. Fuel valve
- EK Reset button
- FR Flame relay
- fr Flame relay contacts
- FS Flame aight signal
- G Burner motor
- K Flame relay anchor to delay the tzl command in the event of a premature flame signal or endorse it where the signal is correct.
- OH light oil pre-heater
- OW Operational all-clear contact
- QRB Photo-resistant cell (flame detector)
- R Thermostat or pressure switch
- TZ Thermo-electric programmer (bimetal system)
- tz.. TZ contacts
- V Flame signal amplifier
- W Safety thermostat or pressure switch
- Z Ignition transformer

The above are safety devices!

To tamper with them in any way may have unforeseeable consequences!

Do not open them!

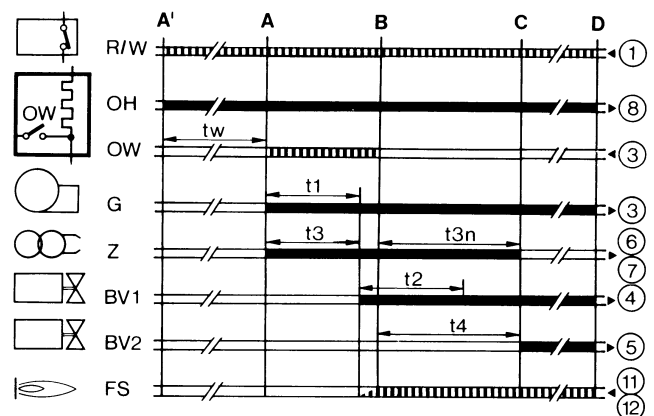

Technical characteristics

- Voltage 220V -15%...240V+10% or 100V -15%...110V+10%

Frequency	50...60Hz +/- 6%
External fuse	max.10A slow action
Contact flow:	
- terminal 1	5A
- terminal 3	5A (incl.capacity absorbed by motor and pre-heater)
Terminal flow:	
terminals 4, 5 &10	1A
terminals 6&7	2A
terminal 8	5A
Absorbed cap	3VA
Protection	IP40
Permitted temp:	
operational	-20...+60°C
transport & storage	-50...+60°C
Emplacement	any
Mass (weight)	controller 180g, socket 50g, AGK accessories 12 g.

Commands in the event of operational interference

Stray light/premature ignition

During pre-purge and/or pre-ignition there should be no flamesignal. If there is a flame signal, eg from premature ignition due to a faulty solenoid, external light, short circuit in the photoresisto or wiring, malfunction in the flame signal amplifier, etc., at the end of pre-purge and safety time the controller locks out the burner and stops the fuel flow even during safety time.

Absence of flame

If there is no flame at the end of safety time the controller locks out immediately.

Absence of flame during operation

If there is no flame during operation the controller cuts off the supply of fuel and automatically initiates a fresh start-up programme: at the end of t4 the start-up programme ends.

Whenever there is a safety stop, terminals 3-8 and 11 are de-energised in less than 1 second; at the same time a remote lockout signal is transmitted through terminal 10. The controller can be reset after c. 50 seconds.

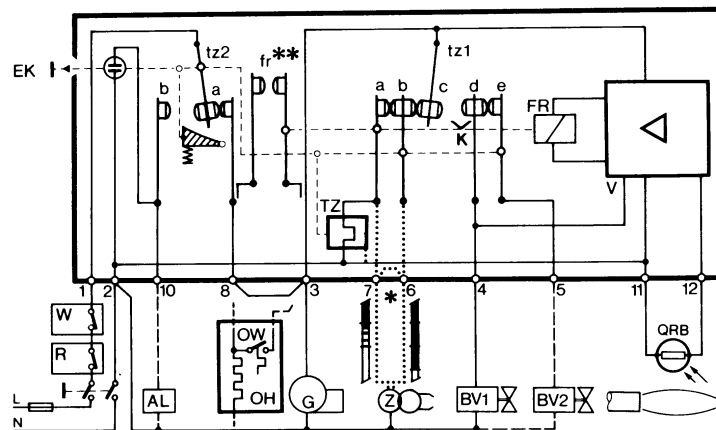

the burner control will initiate lock-out.

Controlled intermittent operation

After no more than 24 hours of continuous operation, the burner control will initiate an automatic safety shut-down followed by a restart.

Control sequence in the event of fault

If lock-out occurs, the outputs for the fuel valves and the ignition will immediately be deactivated (< 1 second).

Cause	Response
After a mains failure	Restart
After voltage has fallen below the undervoltage threshold	Restart
In the event of a premature, faulty flame signal during «t1»	Lock-out at the end of «t1»
In the event of a premature, faulty flame signal during «tw»	Prevention of start-up, lock-out after no more than 40 seconds
If the burner does not ignite during «TSA»	Lock-out at the end of TSA
In the event the flame is lost during operation	Max. 3 repetitions, followed by lock-out
Oil pre-heater's release contact does not close within 10 min.	Lock-out

Lock-out

In the event of lock-out, the LMO... remains locked (lock-out cannot be changed), and the red signal lamp will light up. This status is also maintained in the case of a mains failure.

Resetting the burner

Whenever lock-out occurs, the burner control can immediately be reset. To do this, keep control the lock-out reset button depressed for about 1 second (< 3 seconds).

Ignition program with LMO24.113A2

If the flame is lost during «TSA», the burner will be reignited, but not later

SIEMENS OIL BURNERS AUTOMATIC CONTROLLER SIEMENS LMO14 - LMO24 - LMO44

The LMO... burner controls are designed for the start-up and supervision of single- or 2-stage forced draught oil burners in intermittent operation. Yellow-burning flames are supervised with photoresistive detectors QRB..., blue-burning flames with blue-flame detectors QRC...

In terms of housing dimensions, electrical connections and flame detectors, the LMO... are identical to the LOA... oil burner controls.

Preconditions for startup

- Burner control is reset
- All contacts in the line are closed
- No undervoltage
- Flame detector is darkened, no extraneous light

Undervoltage

- Safety shut-down in the operating position takes place should the mains voltage drop below about AC 165 V
- Restart is initiated when the mains voltage exceeds about AC 175 V

Time supervision oil pre-heater

If the oil pre-heater's release contact does not close within 10 minutes,





than at the end of «TSAmax.». This means that several ignition attempts can be made during TSA (refer to «Program sequence»).

Limitation of repetitions

If the flame is lost during operation, a maximum of 3 repetitions can be made. If the flame is lost for the 4th time during operation, the burner will initiate lock-out. The repetition count is restarted each time controlled switching on by «R-W-SB» takes place.

Operation

Lock-out reset button «EK...» is the key operating element for resetting the burner control and for activating / deactivating the diagnostic functions.

-  The multicolour «LED» is the key indicating element for both visual diagnosis and interface diagnosis.
-  Red
-  Yellow
-  Green

Colour code table		
Status	Colour code	Colour
Oil pre-heater heats, waiting time «tw»	llllllllll	Yellow
Ignition phase, ignition controlled	lmlmlmlml	Yellow-off
Operation, flame o.k.	oooooooo	Green
Operation, flame not o.k.	omomomomo	Green-off
Undervoltage	lslslslsl	Yellow-red
Fault, alarm	sssssssss	Red
Output of fault code (refer to Fault code table)	smsmsmsm	Red-off
Extraneous light prior to burner start-up	ososososo	Green-red
Interface diagnosis	sssssssssss	Red flicker light

Key

- m Off
- l Yellow
- o Green
- s Red

Diagnosis of cause of fault

After lock-out, the red fault signal lamp remains steady on. In that condition, the visual diagnosis of the cause of fault according to the error code table can be activated by pressing the lock-out reset button for more than 3 seconds.

Error code table	
Blink code	Possible cause
2 blinks **	No establishment of flame at the end of TSA <ul style="list-style-type: none"> ● Faulty or soiled fuel valves ● Faulty or soiled flame detector ● Poor adjustment of burner, no fuel ● Faulty ignition
3 blinks ***	Free
4 blinks ****	Extraneous light on burner startup
5 blinks *****	Free
6 blinks *****	Free
7 blinks *****	Too many losses of flme during operation (limitattion og the number of repetitions) <ul style="list-style-type: none"> ● Faulty or soiled fuel valves ● Faulty or soiled flame detector ● Poor adjustment of burner
8 blinks *****	Time supervision oil pre-heater
9 blinks *****	Free
10 blinks *****	Wiring error or internal error, output contacts

During the time the cause of fault is diagnosed, the control outputs are deactivated.

- Burner remains shut down
- Fault status signal «AL» at terminal 10 is activated

The diagnosis of the cause of fault is quit and the burner switched on again by resetting the burner control.

Press lock-out reset button for about 1 second (< 3 seconds).

Connection diagram and internal diagram

LMO14

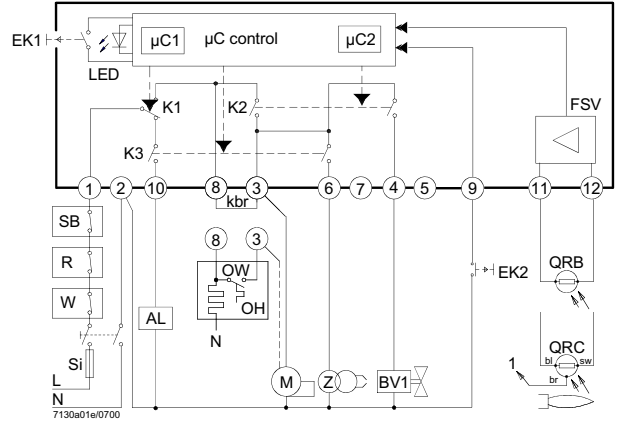

LMO24 - LMO44

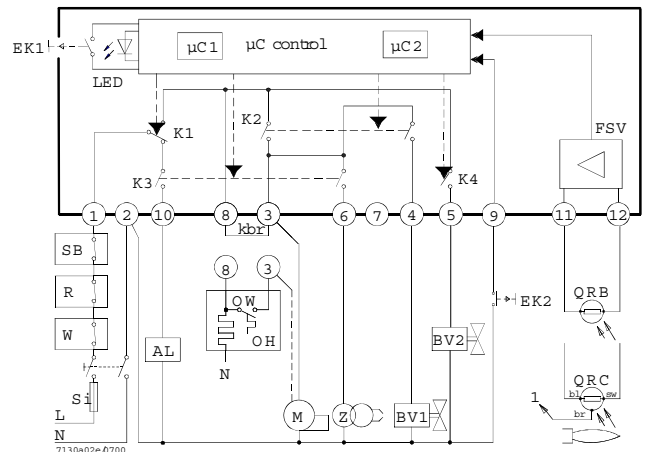

Control sequence

LMO14

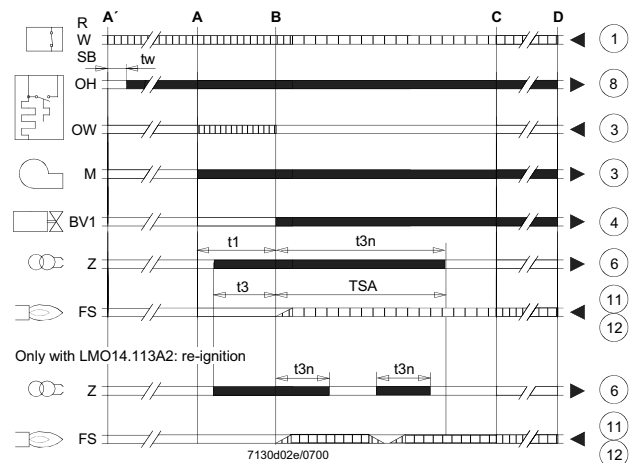

LMO24 - LMO44

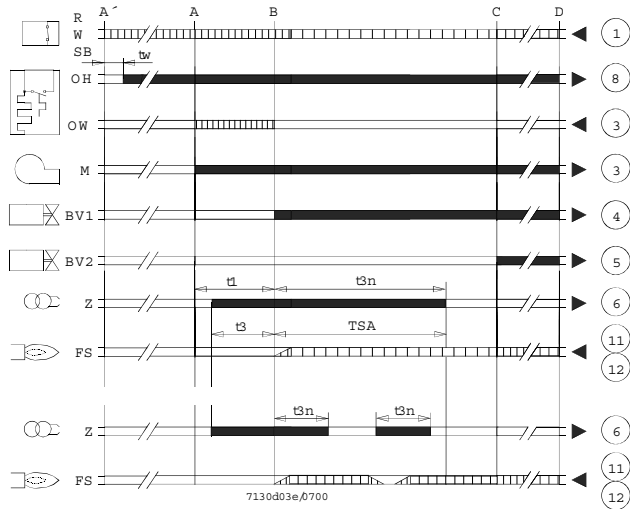

Key

- AL Alarm device
- kbr... Cable link (required only when no oil pre-heater is used)
- BV... Fuel valve
- EK1 Lock-out reset button
- EK2 Remote lock-out reset button
- FS Flame signal
- FSV Flame signal amplifier
- K... Contacts of control relay
- LED 3-colour signal lamps
- M Burner motor
- OW Release contact of oil pre-heater
- t1 Pre-purge time
- t3 Pre-ignition time
- t3n Post-ignition time
- A' Beginning of start-up sequence with burners using an oil pre-heater
- A Beginning of start-up sequence with burners using no oil pre-heater
- Controller output signals
- Required input signals
- OH Oil pre-heater
- QRB Photoresistive detector
- QRC Blue-flame detector
- bl = blue
- br = brown
- sw = black
- R Control thermostat or pressurestat
- SB Safety limit thermostat
- Si External primary fuse
- W Limit thermostat or pressure switch
- Z Ignition transformer
- t4 Interval from flame signal to release «BV2»
- TSA Ignition safety time
- tw Waiting time for oil pre-heating
- B Time of flame establishment
- C Operating position
- D Controlled shut-down by «R»
- μC1 Microcontroller 1
- μC2 Microcontroller 2

General unit data

Mains voltage	AC 230 V +10 % / -15 % AC 120 V +10 % / -15 %
Mains frequency	50...60 Hz ±6 %
External primary fuse (Si)	6.3A (slow)
Power consumption	12 VA
Mounting orientation	optional
Weight	approx. 200 g
Degree of protection	IP40 (to be ensured through mounting)
Perm. cable lengths	max. 3m at line capacitance of 100 pF/m
Detector cable laid separately	10 m
Remote reset laid separately	20m

	LMO14	LMO24	LMO44
Terminal 1	5 A	5 A	5 A
Terminals 3 and 8	3 A	5 A	5 A
Terminals 4, 5 and 10	1 A	1 A	1 A
Terminals 6	1 A	1 A	2 A

Flame supervision with QRB and QRC

	QRB	QRC
Min. detector current required (with flame)	45 μA	70 μA
Min detector current permitted (without flame)	5.5 μA	5.5 μA
Max. possible with flame (typically)	100 μA	100 μA

Measurement circuit for detector current

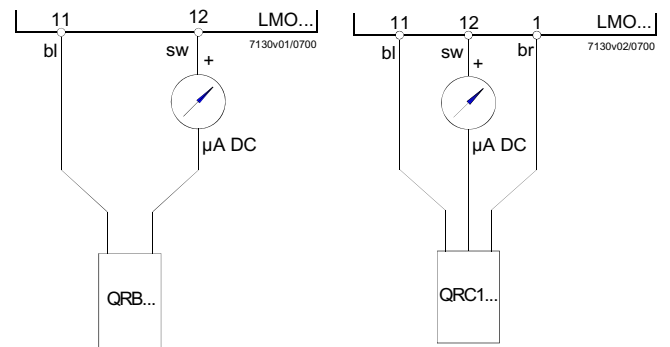

Key

- μA DC DC microammeter with an internal resistance of 5 kΩ max.
- bl Blue
- sw Black
- br Brown









C.I.B. UNIGAS S.p.A.
Via L.Galvani, 9 - 35011 Campodarsego (PD) - ITALY
Tel. +39 049 9200944 - Fax +39 049 9200945/9201269
web site: www.cibunigas.it - e-mail: cibunigas@cibunigas.it

Note: Specifications and and data subject to change. Errors and omissions excepted.

VERSIONE MONOSTADIO "TN"
"TN" SINGLE-STAGE VERSION

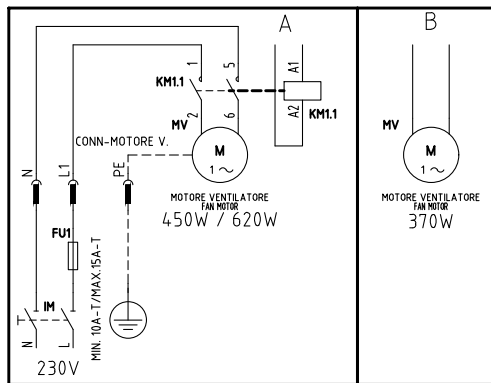
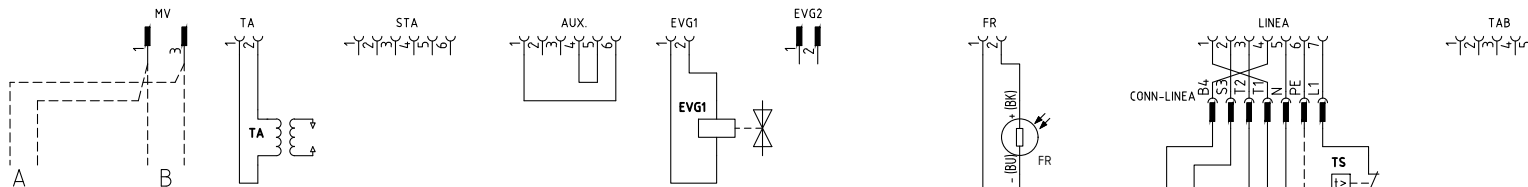
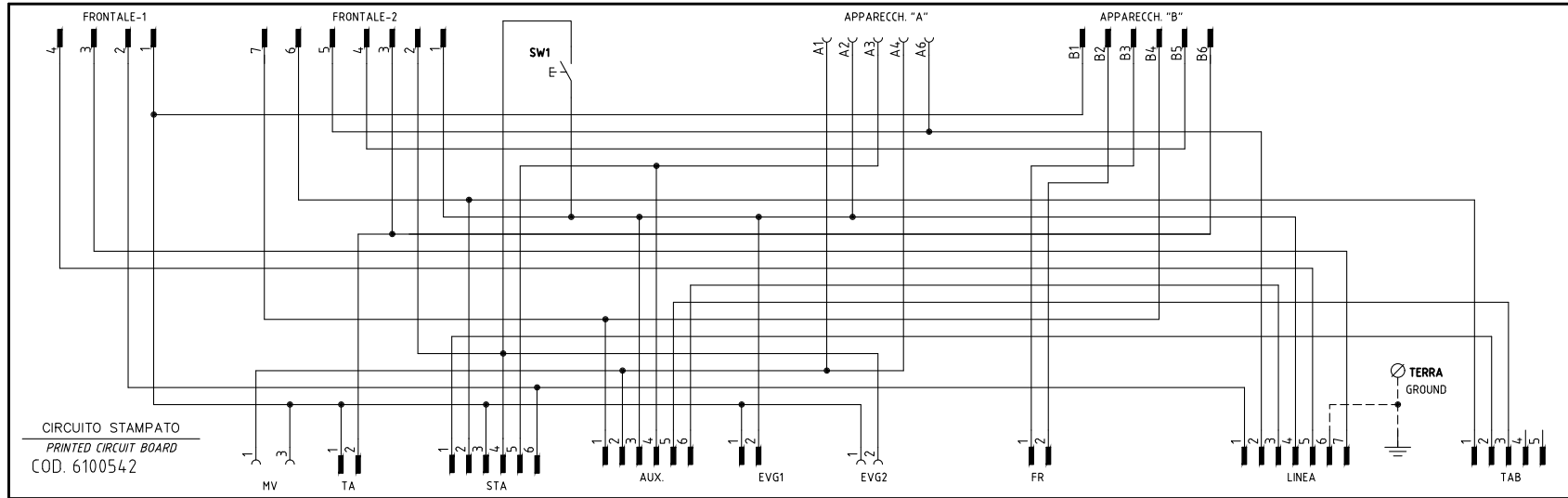
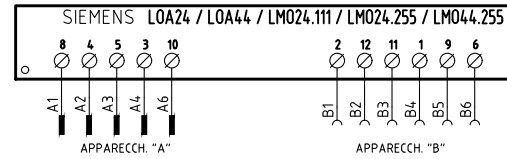
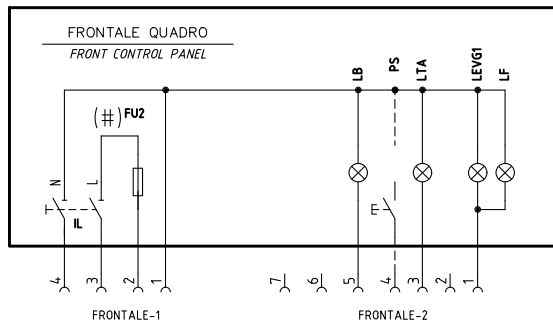

(#) MOTORE VENTIL. 450W O 620W, FU2 = 6,3A F; MOTORE VENTIL. 370W, FU2 = 10A F
FAN MOTOR 450W OR 620W, FU2 = 6,3A F; FAN MOTOR 370W FU2 = 10A F



Impianto
TIPI/TYPES LO400 - LO550
MODELLO/MODEL G-.TN(AB). x.xx.A.x
Descrizione

Ordine
Commissa
Esecutore
U. PINTON

Data Contrallato
07/01/2013

Controllato
S. MARCHETTI

Data 13/10/2004
Revisione **04**
Dis. N. **18 - 0049**

PREC. /
FOGLIO **1**
SEQUE 2
TOTALE 3

REV.	MODIFICA	DATA	FIRME
04	AGGIUNTO/ADDED LMO24-255	07/01/13	U. PINTON
03	AGGIUNTO/ADDED "SQN72..."	22/05/09	U. PINTON
02	CORRETTO/CORRECT "CONN. EVG2"	04/04/08	U. PINTON
01	AGGIUNTO/ADDED LO550	19/09/07	U. PINTON

VERSIONE ALTA-BASSA FIAMMA "AB"
"AB" HIGH/LOW FLAME VERSION

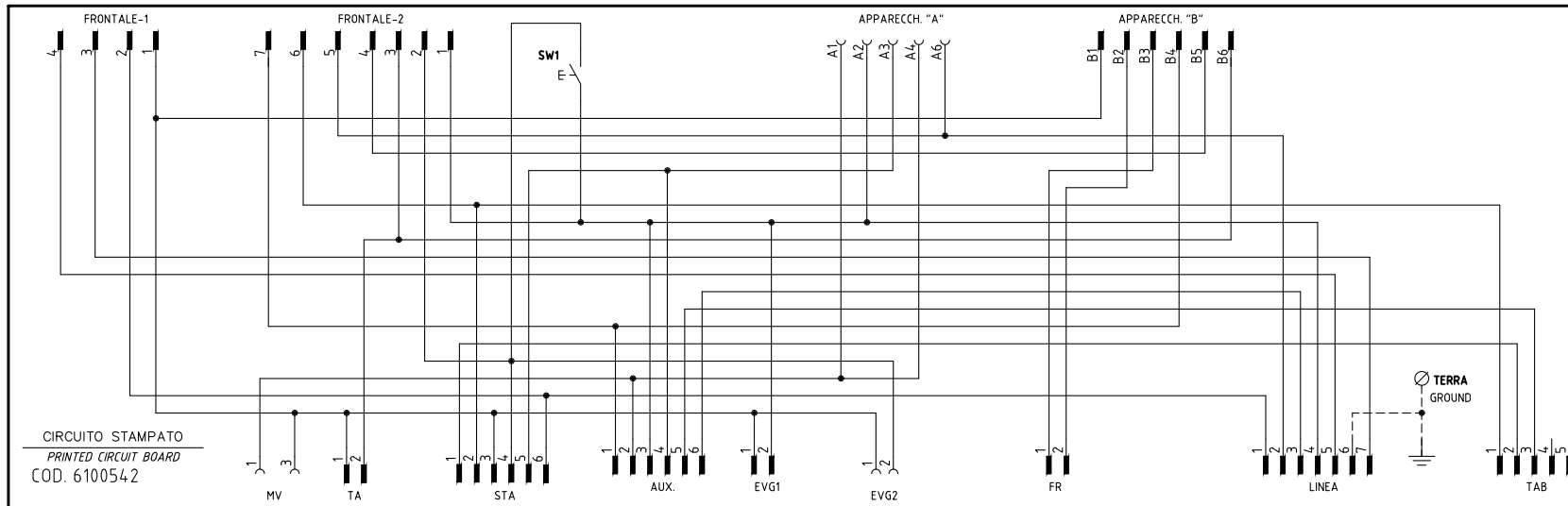
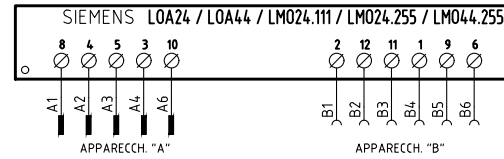
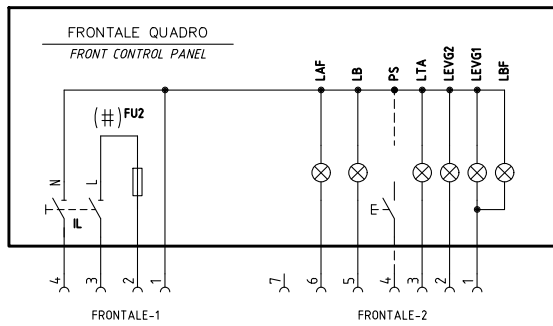

SERVOCOMANDO SERRANDA ARIA
AIR DAMPER ACTUATOR
STA4.5B0.37/63N30L

- I ALTA FIAMMA
HIGH FLAME
- II SOSTA ACCENSIONE, BASSA FIAMMA
STAND-BY, IGNITION, LOW FLAME
- III APERTURA EVG2
OPEN EVG2

SERVOCOMANDO SERRANDA ARIA (ALTERNATIVO)
AIR DAMPER ACTUATOR (ALTERNATIVE)
SQN72.2A4A20

- I (ROSSO) ALTA FIAMMA
I (RED) HIGH FLAME
- II (BLU) SOSTA ACCENSIONE, BASSA FIAMMA
II (BLUE) STAND-BY, IGNITION, LOW FLAME
- IV (NERO) APERTURA EVG2
IV (BLACK) OPEN EVG2

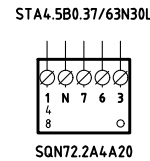
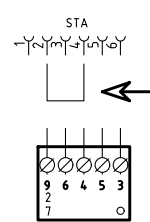
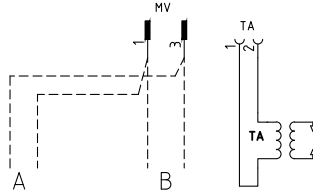

VERSIONE CON MARTINETTO IDRAULICO
WITH HYDRAULIC RAM VERSION

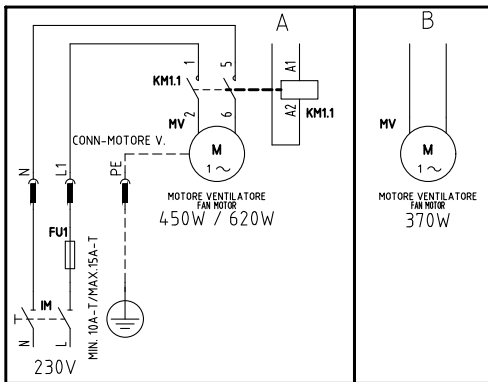
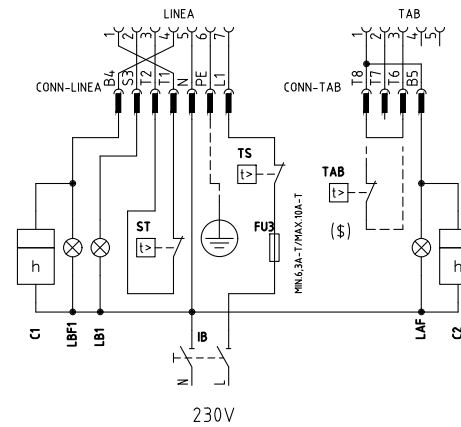
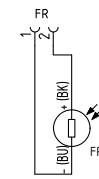
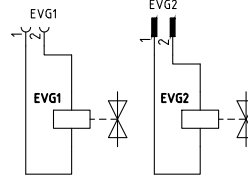

(#) MOTORE VENTIL. 450W O 620W, FU2 = 6,3A F; MOTORE VENTIL. 370W, FU2 = 10A F
FAN MOTOR 450W OR 620W, FU2 = 6,3A F; FAN MOTOR 370W FU2 = 10A F

(\$) SE PREVISTO "TAB", TOGLIERE IL PONTE TRA I MORSETTI T6-T8
IF "TAB" USED REMOVE THE BRIDGE BETWEEN TERMINALS T6-T8

Data	13/10/2004	PREC.	FOGLIO
Revisione	04	1	2
Dis. N.	18 - 0049	SEGUE	TOTALE
		3	3

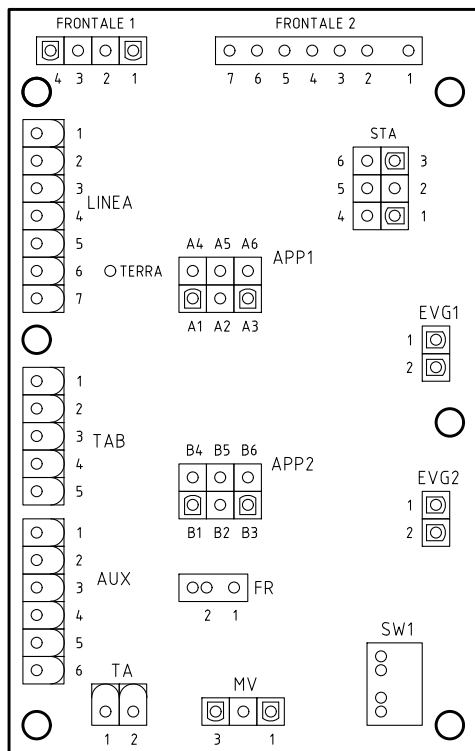

SIGLA/ITEM	Funzione	FUNCTION
C1	CONTAORE BASSA FIAMMA	LOW FLAME TIME COUNTER
C2	CONTAORE ALTA FIAMMA	HIGH FLAME TIME COUNTER
EVG1	ELETTROVALVOLA GASOLIO BASSA FIAMMA	LOW FLAME LIGHT OIL SOLENOID VALVE
EVG2	ELETTROVALVOLA GASOLIO ALTA FIAMMA	HIGH FLAME LIGHT OIL SOLENOID VALVE
FR	FOTORESISTENZA RILEVAZIONE FIAMMA	PHOTORESISTOR FLAME DETECTOR
FU1	FUSIBILE LINEA MOTORE VENTILATORE	FAN MOTOR LINE FUSE
FU2	FUSIBILE DI LINEA	LINE FUSE
FU3	FUSIBILE LINEA BRUCIATORE	BURNER LINE FUSE
IB	INTERRUTTORE LINEA BRUCIATORE	BURNER LINE SWITCH
IL	INTERRUTTORE LINEA AUSILIARI	AUXILIARY LINE SWITCH
IM	INTERRUTTORE LINEA MOTORE VENTILATORE	FAN MOTOR LINE SWITCH
KM1.1	CONTATTORE MOTORE VENTILATORE	FAN MOTOR CONTACTOR
LAF	LAMPADA SEGNALAZIONE ALTA FIAMMA BRUCIATORE	BURNER IN HIGH FLAME INDICATOR LIGHT
LB	LAMPADA SEGNALAZIONE BLOCCO BRUCIATORE	INDICATOR LIGHT FOR BURNER LOCK-OUT
LB1	LAMPADA SEGNALAZIONE BLOCCO BRUCIATORE	INDICATOR LIGHT FOR BURNER LOCK-OUT
LBF	LAMPADA SEGNALAZIONE BASSA FIAMMA BRUCIATORE	BURNER IN LOW FLAME INDICATOR LIGHT
LBF1	LAMPADA SEGNALAZIONE BASSA FIAMMA BRUCIATORE	BURNER IN LOW FLAME INDICATOR LIGHT
LEV1	LAMPADA SEGNALAZIONE APERTURA [EVG1]	INDICATOR LIGHT FOR OPENING OF ELECTRO-VALVE [EVG1]
LEV2	LAMPADA SEGNALAZIONE APERTURA [EVG2]	INDICATOR LIGHT FOR OPENING OF ELECTRO-VALVE [EVG2]
LF	LAMPADA SEGNALAZIONE FUNZIONAMENTO BRUCIATORE	INDICATOR LIGHT BURNER OPERATION
LOA.. / LMO..	APPARECCHIATURA CONTROLLO FIAMMA	CONTROL BOX
LTA	LAMPADA SEGNALAZIONE TRASFORMATORE DI ACCENSIONE	IGNITION TRANSFORMER INDICATOR LIGHT
MV	MOTORE VENTILATORE	FAN MOTOR
PS	PULSANTE SBLOCCO FIAMMA (SOLO CON LOA44 E LMO..)	LOCK-OUT RESET BUTTON (WITH LOA44 AND LMO.. ONLY)
SQ72.2A4A20	SERVOCOMANDO SERRANDA ARIA (ALTERNATIVO)	AIR DAMPER ACTUATOR (ALTERNATIVE)
ST	SERIE TERMOSTATI/PRESSOSTATI	SERIES OF THERMOSTATS OR PRESSURE SWITCHES
STA4.5B0.37/63N30L	SERVOCOMANDO SERRANDA ARIA	AIR DAMPER ACTUATOR
SW1	PULSANTE INNESCO SECONDO STADIO BRUCIATORE	II° STAGE BURNER START BUTTON
TA	TRASFORMATORE DI ACCENSIONE	IGNITION TRANSFORMER
TAB	TERMOSTATO/PRESSOSTATO ALTA-BASSA FIAMMA	HIGH-LOW THERMOSTAT/PRESSURE SWITCHES
TS	TERMOSTATO/PRESSOSTATO DI SICUREZZA	SAFETY THERMOSTAT OR PRESSURE SWITCH

Data	13/10/2004	PREC.	FOGLIO
Revisione	04	2	3
Dis. N.	18 - 0049	SEGUE	TOTALE
		/	3