

LG/NG/NGX280 LG/NG/NGX350 LG/NG/NGX400



IDEA Series Gas burners

MANUAL OF INSTALLATION - USE - MAINTENANCE

CIB UNIGAS

BURNERS - BRUCIATORI - BRULERS - BRENNER - QUEMADORES - ГОРЕЛКИ

DANGERS, WARNINGS AND NOTES OF CAUTION

THIS MANUAL IS SUPPLIED AS AN INTEGRAL AND ESSENTIAL PART OF THE PRODUCT AND MUST BE DELIVERED TO THE USER.

INFORMATION INCLUDED IN THIS SECTION ARE DEDICATED BOTH TO THE USER AND TO PERSONNEL FOLLOWING PRODUCT INSTALLATION AND MAINTENANCE.

THE USER WILL FIND FURTHER INFORMATION ABOUT OPERATING AND USE RESTRICTIONS, IN THE SECOND SECTION OF THIS MANUAL. WE HIGHLY RECOMMEND TO READ IT.

CAREFULLY KEEP THIS MANUAL FOR FUTURE REFERENCE.

1) GENERAL INTRODUCTION

- The equipment must be installed in compliance with the regulations in force, following the manufacturer's instructions, by qualified personnel.
- Qualified personnel means those having technical knowledge in the field of components for civil or industrial heating systems, sanitary hot water generation and particularly service centres authorised by the manufacturer.
- Improper installation may cause injury to people and animals, or damage to property, for which the manufacturer cannot be held liable.
- Remove all packaging material and inspect the equipment for integrity. In case of any doubt, do not use the unit - contact the supplier.

The packaging materials (wooden crate, nails, fastening devices, plastic bags, foamed polystyrene, etc), should not be left within the reach of children, as they may prove harmful.

- Before any cleaning or servicing operation, disconnect the unit from the mains by turning the master switch OFF, and/or through the cut-out devices that are provided.
- Make sure that inlet or exhaust grilles are unobstructed.
- In case of breakdown and/or defective unit operation, disconnect the unit. Make no attempt to repair the unit or take any direct action.

Contact qualified personnel only.

Units shall be repaired exclusively by a servicing centre, duly authorised by the manufacturer, with original spare parts and accessories.

Failure to comply with the above instructions is likely to impair the unit's safety.

To ensure equipment efficiency and proper operation, it is essential that maintenance operations are performed by qualified personnel at regular intervals, following the manufacturer's instructions.

- When a decision is made to discontinue the use of the equipment, those parts likely to constitute sources of danger shall be made harmless.
- In case the equipment is to be sold or transferred to another user, or in case the original user should move and leave the unit behind, make sure that these instructions accompany the equipment at all times so that they can be consulted by the new owner and/or the installer.
- This unit shall be employed exclusively for the use for which it is meant. Any other use shall be considered as improper and, therefore, dangerous.

The manufacturer shall not be held liable, by agreement or otherwise, for damages resulting from improper installation, use and failure to comply with the instructions supplied by the manufacturer. The occurrence of any of the following circumstances may cause explosions, polluting unburnt gases (example: carbon monoxide CO), burns, serious harm to people, animals and things:

- Failure to comply with one of the WARNINGS in this chapter
- Incorrect handling, installation, adjustment or maintenance of the burner
- Incorrect use of the burner or incorrect use of its parts or optional supply

2) SPECIAL INSTRUCTIONS FOR BURNERS

- The burner should be installed in a suitable room, with ventilation openings complying with the requirements of the regulations in force, and sufficient for good combustion.
- Only burners designed according to the regulations in force should be used.
- This burner should be employed exclusively for the use for which it was designed.
- Before connecting the burner, make sure that the unit rating is the same as delivery mains (electricity, gas oil, or other fuel).
- Observe caution with hot burner components. These are, usually, near to the flame and the fuel pre-heating system, they become hot during the unit operation and will remain hot for some time after the burner has stopped.

When the decision is made to discontinue the use of the burner, the user shall have qualified personnel carry out the following operations:

- a Remove the power supply by disconnecting the power cord from the mains.
- b Disconnect the fuel supply by means of the hand-operated shut-off valve and remove the control handwheels from their spindles.

Special warnings

- Make sure that the burner has, on installation, been firmly secured to the appliance, so that the flame is generated inside the appliance fire-box.
- Before the burner is started and, thereafter, at least once a year, have qualified personnel perform the following operations:
 - a set the burner fuel flow rate depending on the heat input of the appliance;
 - b set the flow rate of the combustion-supporting air to obtain a combustion efficiency level at least equal to the lower level required by the regulations in force;
 - c check the unit operation for proper combustion, to avoid any harmful or polluting unburnt gases in excess of the limits permitted by the regulations in force;
 - d make sure that control and safety devices are operating properly;
 - e make sure that exhaust ducts intended to discharge the products of combustion are operating properly;
 - f on completion of setting and adjustment operations, make sure that all mechanical locking devices of controls have been duly tightened;
 - g make sure that a copy of the burner use and maintenance instructions is available in the boiler room.
- In case of a burner shut-down, reset the control box by means of the RESET pushbutton. If a second shut-down takes place, call the Technical Service, **without trying to RESET further**.
- The unit shall be operated and serviced by qualified personnel only, in compliance with the regulations in force.

3) GENERAL INSTRUCTIONS DEPENDING ON FUEL USED

3a) ELECTRICAL CONNECTION

- For safety reasons the unit must be efficiently earthed and installed as required by current safety regulations.
- It is vital that all safety requirements are met. In case of any doubt, ask for an accurate inspection of electrics by qualified personnel, since the manufacturer cannot be held liable for damages that may be caused by failure to correctly earth the equipment.
- Qualified personnel must inspect the system to make sure that it is adequate to take the maximum power used by the equipment shown on the equipment rating plate. In particular, make sure that the system cable cross section is adequate for the power absorbed by the unit.
- No adaptors, multiple outlet sockets and/or extension cables are permitted to connect the unit to the electric mains.
- An omnipolar switch shall be provided for connection to mains, as required by the current safety regulations.
- The use of any power-operated component implies observance of a few basic rules, for example:
 - do not touch the unit with wet or damp parts of the body and/or with bare feet;
 - do not pull electric cables;
 - do not leave the equipment exposed to weather (rain, sun, etc.) unless expressly required to do so;
 - do not allow children or inexperienced persons to use equipment;
- The unit input cable shall not be replaced by the user. In case of damage to the cable, switch off the unit and contact qualified personnel to replace. When the unit is out of use for some time the electric switch supplying all the power-driven components in the system (i.e. pumps, burner, etc.) should be switched off.

3b) FIRING WITH GAS, LIGHT OIL OR OTHER FUELS

GENERAL

- The burner shall be installed by qualified personnel and in compliance with regulations and provisions in force; wrong installation can cause injuries to people and animals, or damage to property, for which the manufacturer cannot be held liable.
- Before installation, it is recommended that all the fuel supply system pipes be carefully cleaned inside, to remove foreign matter that might impair the burner operation.
- Before the burner is commissioned, qualified personnel should inspect the following:
 - a the fuel supply system, for proper sealing;
 - b the fuel flow rate, to make sure that it has been set based on the firing rate required of the burner;
 - c the burner firing system, to make sure that it is supplied for the designed fuel type;
 - d the fuel supply pressure, to make sure that it is included in the range shown on the rating plate;
 - e the fuel supply system, to make sure that the system dimensions are adequate to the burner firing rate, and that the system is equipped with all the safety and control devices required by the regulations in force.
- When the burner is to remain idle for some time, the fuel supply tap or taps should be closed.

SPECIAL INSTRUCTIONS FOR USING GAS

Have qualified personnel inspect the installation to ensure that:

- a the gas delivery line and train are in compliance with the regulations and provisions in force;
 - b all gas connections are tight;
 - c the boiler room ventilation openings are such that they ensure the air supply flow required by the current regulations, and in any case are sufficient for proper combustion.
- Do not use gas pipes to earth electrical equipment.
 - Never leave the burner connected when not in use. Always shut the gas valve off.
 - In case of prolonged absence of the user, the main gas delivery valve to the burner should be shut off.

Precautions if you can smell gas

- a do not operate electric switches, the telephone, or any other item likely to generate sparks;
 - b immediately open doors and windows to create an air flow to purge the room;
 - c close the gas valves;
 - d contact qualified personnel.
- Do not obstruct the ventilation openings of the room where gas appliances are installed, to avoid dangerous conditions such as the development of toxic or explosive mixtures.

DIRECTIVES AND STANDARDS

Gas burners

European directives

- Regulation 2016/426/UE (appliances burning gaseous fuels)
- 2014/35/UE (Low Tension Directive)
- 2014/30/UE (Electromagnetic compatibility Directive)
- 2006/42/EC (Machinery Directive)

Harmonized standards

- UNI EN 676 (Automatic forced draught burners for gaseous fuels)
- EN 55014-1 (Electromagnetic compatibility- Requirements for household appliances, electric tools and similar apparatus)
- EN 60204-1:2006 (Safety of machinery – Electrical equipment of machines.)
- CEI EN 60335-1 (Specification for safety of household and similar electrical appliances);
- CEI EN 60335-2-102 (Household and similar electrical appliances. Safety. Particular requirements for gas, oil and solid-fuel burning appliances having electrical connections).
- UNI EN ISO 12100:2010 (Safety of machinery - General principles for design - Risk assessment and risk reduction);

Light oil burners

European directives

- 2014/35/UE (Low Tension Directive)
- 2014/30/UE (Electromagnetic compatibility Directive)
- 2006/42/EC (Machinery Directive)

Harmonized standards

- UNI EN 267-2011(Automatic forced draught burners for liquid fuels)
- EN 55014-1 (Electromagnetic compatibility- Requirements for household appliances, electric tools and similar apparatus)
- EN 60204-1:2006 (Safety of machinery – Electrical equipment of machines.)
- CEI EN 60335-1 (Specification for safety of household and similar electrical appliances);
- CEI EN 60335-2-102 (Household and similar electrical appliances. Safety. Particular requirements for gas, oil and solid-fuel burning appliances having electrical connections).
- UNI EN ISO 12100:2010 (Safety of machinery - General principles for design - Risk assessment and risk reduction);

Heavy oil burners

European Directives

- 2014/35/UE (Low Tension Directive)
- 2014/30/UE (Electromagnetic compatibility Directive)
- 2006/42/EC (Machinery Directive)

Harmonized standards

- UNI EN 267(Automatic forced draught burners for liquid fuels)
- EN 55014-1 (Electromagnetic compatibility- Requirements for household appliances, electric tools and similar apparatus)
- EN 60204-1:2006 (Safety of machinery – Electrical equipment of machines.)
- CEI EN 60335-1 (Specification for safety of household and similar electrical appliances);
- CEI EN 60335-2-102 (Household and similar electrical appliances. Safety. Particular requirements for gas, oil and solid-fuel burning appliances having electrical connections).
- UNI EN ISO 12100:2010 (Safety of machinery - General principles for design - Risk assessment and risk reduction);

Gas - Light oil burners

European Directives

- Regulation 2016/426/UE (appliances burning gaseous fuels)
- 2014/35/UE (Low Tension Directive)
- 2014/30/UE (Electromagnetic compatibility Directive)
- 2006/42/EC (Machinery Directive)

Harmonized standards

- UNI EN 676 (Automatic forced draught burners for gaseous fuels)
- UNI EN 267 (Automatic forced draught burners for liquid fuels)
- EN 55014-1 (Electromagnetic compatibility- Requirements for household appliances, electric tools and similar apparatus)
- EN 60204-1:2006 (Safety of machinery – Electrical equipment of machines.)
- CEI EN 60335-1 (Specification for safety of household and similar electrical appliances);
- CEI EN 60335-2-102 (Household and similar electrical appliances. Safety. Particular requirements for gas, oil and solid-fuel burning appliances having electrical connections).
- UNI EN ISO 12100:2010 (Safety of machinery - General principles for design - Risk assessment and risk reduction);

Gas - Heavy oil burners

European directives:

- Regulation 2016/426/UE (appliances burning gaseous fuels)
- 2014/35/UE (Low Tension Directive)
- 2014/30/UE (Electromagnetic compatibility Directive)
- 2006/42/EC (Machinery Directive)

Harmonized standards

- UNI EN 676 (Automatic forced draught burners for gaseous fuels)
- EN 55014-1 (Electromagnetic compatibility- Requirements for household appliances, electric tools and similar apparatus)
- EN 60204-1:2006 (Safety of machinery – Electrical equipment of machines.)
- CEI EN 60335-1 (Specification for safety of household and similar electrical appliances);
- CEI EN 60335-2-102 (Household and similar electrical appliances. Safety. Particular requirements for gas, oil and solid-fuel burning appliances having electrical connections).
- UNI EN ISO 12100:2010 (Safety of machinery - General principles for design - Risk assessment and risk reduction);

Industrial burners

European directives

- Regulation 2016/426/UE (appliances burning gaseous fuels)
- 2014/35/UE (Low Tension Directive)
- 2014/30/UE (Electromagnetic compatibility Directive)
- 2006/42/EC (Machinery Directive)

Harmonized standards

- EN 55014-1 (Electromagnetic compatibility- Requirements for household appliances, electric tools and similar apparatus)
- EN 746-2 (Industrial thermoprocessing equipment - Part 2: Safety requirements for combustion and fuel handling systems)
- UNI EN ISO 12100:2010 (Safety of machinery - General principles for design - Risk assessment and risk reduction);
- EN 60204-1:2006 (Safety of machinery – Electrical equipment of machines.)
- EN 60335-2 (Electrical equipment of non-electric appliances for household and similar purposes. Safety requirements)

Burner data plate

For the following information, please refer to the data plate:

- burner type and burner model: must be reported in any communication with the supplier
- burner ID (serial number): must be reported in any communication with the supplier
- date of production (year and month)
- information about fuel type and network pressure

Type	--
Model	--
Year	--
S.Number	--
Output	--
Oil Flow	--
Fuel	--
Category	--
Gas Pressure	--
Viscosity	--
El.Supply	--
El.Consump.	--
Fan Motor	--
Protection	--
Drwaing n°	--
P.I.N.	--

SYMBOLS USED



WARNING!

Failure to observe the warning may result in irreparable damage to the unit or damage to the environment



DANGER!

Failure to observe the warning may result in serious injuries or death.



WARNING!

Failure to observe the warning may result in electric shock with lethal consequences

Figures, illustrations and images used in this manual may differ in appearance from the actual product.

BURNER SAFETY

The burners - and the configurations described below - comply with the regulations in force regarding health, safety and the environment. For more in-depth information, refer to the declarations of conformity that are an integral part of this Manual.



DANGER! Incorrect motor rotation can seriously damage property and injure people.

Residual risks deriving from misuse and prohibitions

The burner has been built in order to make its operation safe; there are, however, residual risks.



Do not touch any mechanical moving parts with your hands or any other part of your body. Injury hazard
Do not touch any parts containing fuel (i.e. tank and pipes). Scalding hazard
Do not use the burner in situations other than the ones provided for in the data plate.
Do not use fuels other than the ones stated.
Do not use the burner in potentially explosive environments.
Do not remove or by-pass any machine safety devices.
Do not remove any protection devices or open the burner or any other component while the burner is running.
Do not disconnect any part of the burner or its components while the burner is running.
Untrained staff must not modify any linkages.



After any maintenance, it is important to restore the protection devices before restarting the machine.
All safety devices must be kept in perfect working order.
Personnel authorized to maintain the machine must always be provided with suitable protections.



ATTENTION: while running, the parts of the burner near the generator (coupling flange) are subject to overheating. Where necessary, avoid any contact risks by wearing suitable PPE.

PART I: SPECIFICATIONS

GENERAL FEATURES

These burners are characterised by high performances and width in the performance curves, when the pressure in the combustion chamber is high. They are also characterised for other important functional features: there are plugs which can be easily connected to the boiler and to the detecting probes, a pressure plug in the combustion chamber, all mechanical components are mounted on a plate which can be quickly taken off for maintenance. The head is adjustable through a graduated screw. The gas train can be mounted either on the right side or on the left side.

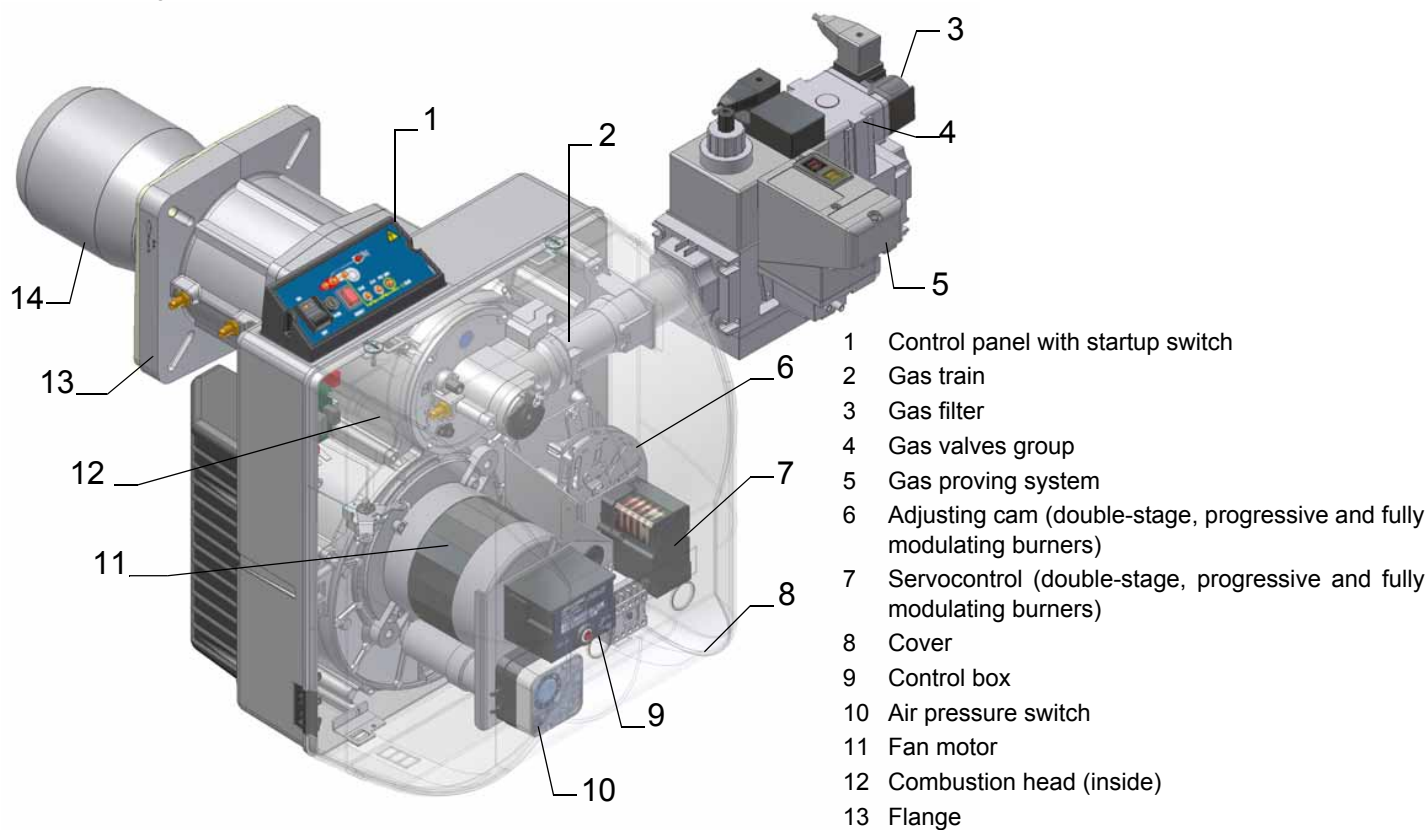

The gas coming from the supply line, passes through the valves group provided with filter and stabiliser. This one forces the pressure in the utilisation limits. In the double-stage, progressive and fully-modulating burners, the electric servocontrol (7), that moves proportionally the air damper and the gas butterfly valve, uses an adjusting cam with variable shape. This one allows the optimisation of the gas flue values, as to get an efficient combustion. The combustion head positioning determines the burner's output. The combustion head (1) determines the energetic quality and the geometry of the flame. Fuel and comburent are routed into separated ways as far as the zone of flame generation (combustion chamber). The air (comburent) and fuel (gas, gas oil, heavy oil) are forced into the combustion chamber. The control panel, placed on the burner's front side, shows each operating stage.

Burners are identified by burner type and model.

Type	Model	M-	PR.	S.	*	A.	0.	50
(1)		(2)	(3)	(4)	(5)	(6)	(7)	(8)
(1)	BURNER TYPE	NG - Natural gas burner, LG - L.P.G. burner, NGX - Low NOx burners						
(2)	FUEL	M - Natural gas, L - LPG Biogas						
(3)	OPERATION (Available versions)	TN - Single stage, AB - Double stage PR - Progressive, MD - Fully modulating						
(4)	BLAST TUBE	S - Standard, L - extended modular						
(5)	DESTINATION COUNTRY	* see data plate						
(6)	BURNER VERSION	A - Standard, Y - Special						
(7)	EQUIPMENT	0 = 2 gas valves 1 = 2 Gas valves + gas proving system (optional) 7 = 2 gas valves + maximum gas pressure switch						
(8)	GAS CONNECTION	25 = Rp1, 32 = Rp1 ¹ / ₄ , 40 = Rp1 ¹ / ₂ , 50 = Rp2						

Fuel selection: In order to start the burner with natural gas or biogas oil, the operator must commute the selector on the burner control panel on (1) = natural gas, or (2) = biogas.

If the selector is set on (1) the natural gas cock must be open, while the biogas cock must be closed. Viceversa if the selector is set on (2).

Technical specifications

BURNER TYPE		NG280	NG280	NG280	LG280	LG280	LG280
		M-.TN....0.25	M-.TN....0.32	M-.TN....0.40	L-.TN....0.20	L-.TN....0.25	L-.TN....0.32
Output	min.- max. kW	95 - 300					
Fuel		Natural gas			L.P.G.		
Category		(see next paragraph)			I _{3B/P}		
Gas rate	min.- max. (Stm ³ /h)	10 - 32			3,7 - 11,5		
Gas pressure	min.- max. mbar	(Note2) - 360					
Power supply		110 / 120 / 220 / 230V - 50 / 60 Hz					
Total power consumption	kW	0,55 (50 Hz) - 0,6 (60 Hz)					
Electric motor	kW	0,25 (50 Hz) - 0,3 (60 Hz)					
Protection		IP40					
Approx. weight	kg	47					
Valves size / Gas connection		1" / Rp1	1 ¹ / ₄ / Rp 1 ¹ / ₄	1 ¹ / ₂ / Rp 1 ¹ / ₂	3/4" / Rp3/4	1" / Rp1	1 ¹ / ₄ / Rp 1 ¹ / ₄
Operation		Single stage					
Operating temperature °C		-10 ÷ +50					
Storage Temperature °C		-20 ÷ +60					
Working service*		Intermittent					

BURNER TYPE		NG280	NG280	NG280	LG280	LG280	LG280
		M-.xx...0.25	M-.xx...0.32	M-.xx...0.40	L-.xx...0.20	L-.xx...0.25	L-.xx...0.32
Output	min.- max. kW	65 - 300					
Fuel		Natural gas			L.P.G.		
Category		(see next paragraph)			I _{3B/P}		
Gas rate	min.- max. (Stm ³ /h)	7 - 32			2,5 - 11,5		
Gas Pressure	min.- max. mbar	(Note2) - 360					
Power supply		110 / 120 / 220 / 230V - 50 / 60 Hz					
Total power consumption	kW	0,55 (50 Hz) - 0,6 (60 Hz)					
Electric motor	kW	0,25 (50 Hz) - 0,3 (60 Hz)					
Protection		IP40					
Approx. weight	kg	47					
Valves size / Gas connection		1" / Rp 1	1 ¹ / ₄ / Rp 1 ¹ / ₄	1 ¹ / ₂ / Rp 1 ¹ / ₂	1" / Rp1	1" / Rp1	1 ¹ / ₄ / Rp 1 ¹ / ₄
Operation		Double-stage - Progressive - Fully modulating					
Operating temperature °C		-10 ÷ +50					
Storage Temperature °C		-20 ÷ +60					
Working service*		Intermittent					

Technical specifications

BURNER TYPE		NG350 M-.TN....0.25	NG350 M-.TN....0.32	NG350 M-.TN.....0.40	LG350 L-.TN....0.25	LG350 L-.TN....0.32	LG350 L-.TN.....0.40
Output	min.- max. kW	115 - 330					
Fuel		Natural gas				L.P.G.	
Category		(see next paragraph)				I _{3B/P}	
Gas rate	min.- max. (Stm ³ /h)	12 – 35			4 – 13		
Gas pressure	min.- max. mbar	(Note2) - 360					
Power supply		110 / 120 / 220 / 230V - 50 / 60 Hz					
Total power consumption	kW	0,67 (50 Hz) - 0,75 (60 Hz)					
Electric motor	kW	0,37 (50 Hz) - 0,45 (60 Hz)					
Protection		IP40					
Approx. weight	kg	47					
Valves size / Gas connection		1" / Rp 1	1" ¼ / Rp 1 ¼	1" ½ / Rp 1 ½	1" / Rp1	1" ¼ / Rp 1 ¼	1" ½ / Rp 1 ½
Operation		Single stage					
Operating temperature °C		-10 ÷ +50					
Storage Temperature °C		-20 ÷ +60					
Working service*		Intermittent					

BURNER TYPE		NG350 M-.xx...0.25	NG350 M-.xx...0.32	NG350 M-.xx...0.40	LG350 L-.xx...0.25	LG350 L-.xx...0.32	LG350 L-.xx...0.40
Output	min.- max. kW	80 - 330			85 - 330		
Fuel		Natural gas				L.P.G.	
Category		(see next paragraph)				I _{3B/P}	I _{3B/P}
Gas rate	min.- max. (Stm ³ /h)	8.5 – 35	8.5 – 35	8.5 – 35	3 – 13	3 – 13	3 – 13
Gas pressure	min.- max. mbar	(Note2) - 360					
Power supply		110 / 120 / 220 / 230V - 50 / 60 Hz					
Total power consumption	kW	0,67 (50 Hz) - 0,75 (60 Hz)					
Electric motor	kW	0,37 (50 Hz) - 0,45 (60 Hz)					
Protection		IP40					
Approx. weight	kg	47					
Valves size / Gas connection		1" / Rp 1	1" ¼ / Rp 1 ¼	1" ½ / Rp 1 ½	1" / Rp1	1" ¼ / Rp 1 ¼	1" ½ / Rp 1 ½
Operation		Progressive - Fully modulating					
Operating temperature °C		-10 ÷ +50					
Storage Temperature °C		-20 ÷ +60					
Working service*		Intermittent					

BURNER TYPE		NG400 M-.TN....0.25	NG400 M-.TN....0.32	NG400 M-.TN.....0.40	NG400 M-.TN.....0.50
Output	min.- max. kW	185 - 420			
Fuel		Natural gas			
Category		(see next paragraph)			
Gas rate	min.- max. (Stm ³ /h)	20 - 44.5			
Gas pressure	min.- max. mbar	(Note2) - 360			
Power supply		110 / 120 / 220 / 230V - 50 / 60 Hz			
Total power consumption	kW	0,67 (50 Hz) - 0,75 (60 Hz)			
Electric motor	kW	0,37 (50 Hz) - 0,45 (60 Hz)			
Protection		IP40			
Approx. weight	kg	47			
Valves size / Gas connection		1" / Rp 1	1" ¼ / Rp 1 ¼	1" ½ / Rp 1 ½	2" / Rp 2
Operation		Single-stage			
Operating temperature °C		-10 ÷ +50			
Storage Temperature °C		-20 ÷ +60			
Working service*		Intermittent			

Low NOx burners Technical specifications

BURNER TYPE		NG400	NG400	NG400	NG400
		M-.xx...0.25	M-.xx...0.32	M-.xx...0.40	M-.xx...0.50
Output	min.- max. kW	115 - 420			
Fuel		Natural gas			
Category		(see next paragraph)			
Gas rate	min.- max. (Stm ³ /h)	12 - 44.5			
Gas pressure	min.- max. mbar	(Note2) - 360			
Power supply		110 / 120 / 220 / 230V - 50 / 60 Hz			
Total power consumption	kW	0,67 (50 Hz) - 0,75 (60 Hz)			
Electric motor	kW	0,37 (50 Hz) - 0,45 (60 Hz)			
Protection		IP40			
Approx. weight	kg	47			
Valves size / Gas connection		1" / Rp 1	1" ¼ / Rp 1 ¼	1" ½ / Rp 1" ½	2" / Rp 2
Operation		Progressive - Fully modulating			
Operating temperature °C		-10 ÷ +50			
Storage Temperature °C		-20 ÷ +60			
Working service*		Intermittent			

BURNER TYPE		LG400	LG400	LG400	LG400
		L-.xx...0.25	L-.xx...0.32	L-.xx...0.40	L-.xx...0.50
Output	min.- max. kW	105 - 420			
Fuel		L.P.G.			
Category		I _{3B/P}			
Gas rate	min.- max. (Stm ³ /h)	4 - 16			
Gas pressure	min.- max. mbar	(Note2) - 360			
Power supply		110 / 120 / 220 / 230V - 50 / 60 Hz			
Total power consumption	kW	0,67 (50 Hz) - 0,75 (60 Hz)			
Electric motor	kW	0,37 (50 Hz) - 0,45 (60 Hz)			
Protection		IP40			
Approx. weight	kg	47			
Valves size / Gas connection		1" / Rp 1	1" ¼ / Rp 1 ¼	1" ½ / Rp 1" ½	2" / Rp 2
Operation		Progressive - Fully modulating			
Operating temperature °C		-10 ÷ +50			
Storage Temperature °C		-20 ÷ +60			
Working service*		Intermittent			

BURNER TYPE		LG400	LG400	LG400	LG400
		L-.TN...0.25	L-.TN...0.32	L-.TN...0.40	L-.TN...0.50
Output	min.- max. kW	180 - 420			
Fuel		L.P.G.			
Category		I _{3B/P}			
Gas rate	min.- max. (Stm ³ /h)	6,7 - 15,7			
Gas pressure	min.- max. mbar	(Note2) - 360			
Power supply		110 / 120 / 220 / 230V - 50 / 60 Hz			
Total power consumption	kW	0,67 (50 Hz) - 0,75 (60 Hz)			
Electric motor	kW	0,37 (50 Hz) - 0,45 (60 Hz)			
Protection		IP40			
Approx. weight	kg	47			
Valves size / Gas connection		1" / Rp 1	1" ¼ / Rp 1 ¼	1" ½ / Rp 1" ½	2" / Rp 2
Operation		Single-stage			
Operating temperature °C		-10 ÷ +50			
Storage Temperature °C		-20 ÷ +60			
Working service*		Intermittent			

BURNER TYPE		NGX280 M-.TN...0.25	NGX280 M-.TN...0.32	NGX280 M-.TN...0.40
Output	min.- max. kW	93 - 190		
Fuel		Natural gas		
Category		(see next paragraph)		
Gas rate	min.- max. (Stm ³ /h)	9,8 - 20		
Gas Pressure	min.- max. mbar	(Note2) - 360		
Power supply		110 / 120 / 220 / 230V - 50 / 60 Hz		
Total power consumption	kW	0,55 (50 Hz) - 0,6 (60 Hz)		
Electric motor	kW	0,25 (50 Hz) - 0,3 (60 Hz)		
Protection		IP40		
Approx. weight	kg	47		
Valves size / Gas connection		1" / Rp1	1" ¹ / ₄ / Rp 1 ¹ / ₄	1" ¹ / ₂ / Rp 1 ¹ / ₂
Operation		Single-stage		
Operating temperature °C		-10 ÷ +50		
Storage Temperature °C		-20 ÷ +60		
Working service*		Intermittent		

BURNER TYPE		NGX280 M-.xx...0.25	NGX280 M-.xx...0.32	NGX280 M-.xx...0.40
Output	min.- max. kW	60 - 190		
Fuel		Natural gas		
Category		(see next paragraph)		
Gas rate	min.- max. (Stm ³ /h)	6,4 - 20		
Gas pressure	min.- max. mbar	(Note2) - 360		
Power supply		110 / 120 / 220 / 230V - 50 / 60 Hz		
Total power consumption	kW	0,55 (50 Hz) - 0,6 (60 Hz)		
Electric motor	kW	0,25 (50 Hz) - 0,3 (60 Hz)		
Protection		IP40		
Approx. weight	kg	47		
Valves size / Gas connection		1" / Rp1	1" ¹ / ₄ / Rp 1 ¹ / ₄	1" ¹ / ₂ / Rp 1 ¹ / ₂
Operation		Double-stage - Progressive - Fully modulating		
Operating temperature °C		-10 ÷ +50		
Storage Temperature °C		-20 ÷ +60		
Working service*		Intermittent		

* **NOTE ON THE WORKING SERVICE:** the control box automatically stops after 24h of continuous working. The control box immediately starts up, automatically.

Note1:	All gas flow rates are referred to Stm ³ /h (1013 mbar absolute pressure, 15 °C temperature) and are valid for Biogas gas (net calorific value H _i = 23 MJ/Stm ³);
Note2:	Maximum gas pressure = 360mbar (with Dungs MBDLE) Maximum gas pressure = 500mbar (with Siemens VGD or Dungs MultiBloc MBE)

BURNER TYPE		NGX350 M-xx...0.25	NGX350 M-xx...0.32	NGX350 M-xx...0.40
Output	min.- max. kW	65 - 260		
Fuel		Natural gas		
Category		(see next paragraph)		
Gas rate	min.- max. min.- max.(Stm ³ /h)	7 - 27.5		
Gas pressure	min.- max. mbar	(Note2) - 360		
Power supply		110 / 120 / 220 / 230V - 50 / 60 Hz		
Total power consumption	kW	0,67 (50 Hz) - 0,75 (60 Hz)		
Electric motor	kW	0,37 (50 Hz) - 0,45 (60 Hz)		
Protection		IP40		
Approx. weight	kg	47		
Valves size / Gas connection		1" / Rp1	1" ¹ / ₄ / Rp 1 ¹ / ₄	1" ¹ / ₂ / Rp 1 ¹ / ₂
Operation		Progressive - Fully modulating		
Operating temperature °C		-10 ÷ +50		
Storage Temperature °C		-20 ÷ +60		
Working service*		Intermittent		

BURNER TYPE		NGX400 M-xx...0.25	NGX400 M-xx...0.32	NGX400 M-xx...0.40	NGX400 M-xx...0.50
Output	min.- max. kW	90 - 350			
Fuel		Natural gas			
Category		(see next paragraph)			
Gas rate	min.- max. (Stm ³ /h)	9.5 - 37			
Gas pressure	min.- max. mbar	(Note2) - 360			
Power supply		110 / 120 / 220 / 230V - 50 / 60 Hz			
Total power consumption	kW	0,67 (50 Hz) - 0,75 (60 Hz)			
Electric motor	kW	0,37 (50 Hz) - 0,45 (60 Hz)			
Protection		IP40			
Approx. weight	kg	47			
Valves size / Gas connection		1" / Rp 1	1" ¹ / ₄ / Rp 1 ¹ / ₄	1" ¹ / ₂ / Rp 1" ¹ / ₂	2" / Rp 2
Operation		Progressive - Fully modulating			
Operating temperature °C		-10 ÷ +50			
Storage Temperature °C		-20 ÷ +60			
Working service*		Intermittent			

* **NOTE ON THE WORKING SERVICE:** the control box automatically stops after 24h of continuous working. The control box immediately starts up, automatically.

Note1:	All gas flow rates are referred to Stm ³ /h (1013 mbar absolute pressure, 15 °C temperature) and are valid for Biogas gas (net calorific value H _i = 23 MJ/Stm ³);
Note2:	Maximum gas pressure = 360mbar (with Dungs MBDLE) Maximum gas pressure = 500mbar (with Siemens VGD or Dungs MultiBloc MBE)

Gas categories and countries of application

Countries
AL, AT, BE, BG, CH, CY, DE, DK, EE, ES, FI, FR, GB, GR, HR, HU, IE, IS, IT, LT, LU, LV, MK, MT, NO, NL, PL, PT, RO, SE, SI, SK, TR

Group	
H	L (*)
E	2R (*)
EK (*)	Er (*)
LL (*)	E (R)

(*) Premix type ...N burners are not enabled to work with these gas categories.

The above gas groups can be combined according to the standard EN437:2021 and national situation of countries.

To check if the burner is suitable for the boiler to which it must be installed, the following parameters are needed:

- furnace input, in kW or kcal/h (kW = kcal/h/860);
- backpressure (data are available on the boiler ID plate or in the user's manual).

Example:

Furnace input: 600kW

Backpressure: 4 mbar

In the "Performance curve" diagram, draw a vertical line matching the furnace input value and an horizontal line matching the backpressure value. The burner is suitable if the intersection point A is inside the performance curve.

Data are referred to standard conditions: atmospheric pressure at 1013 mbar, ambient temperature at 15° C.

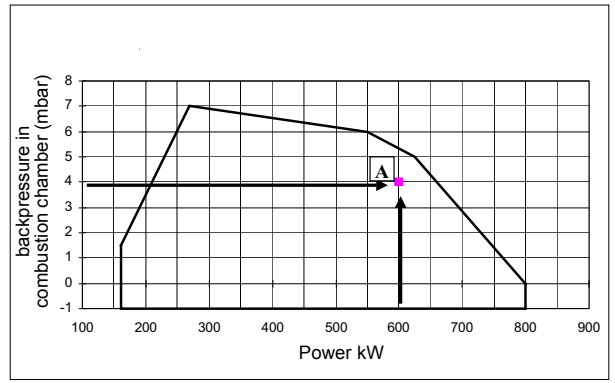

Checking the proper gas train size

To check the proper gas train size, it is necessary to the available gas pressure value upstream the burner's gas valve. Then subtract the backpressure. The result is called **pgas**. Draw a vertical line matching the furnace input value (600kW, in the example), quoted on the x-axis, as far as intercepting the network pressure curve, according to the installed gas train (DN65, in the example). From the interception point, draw an horizontal line as far as matching, on the y-axis, the value of pressure necessary to get the requested furnace input. This value must be lower or equal to the **pgas** value, calculated before.

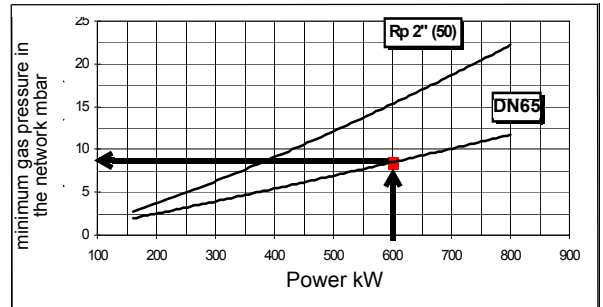

Performance Curves

- Gas burners

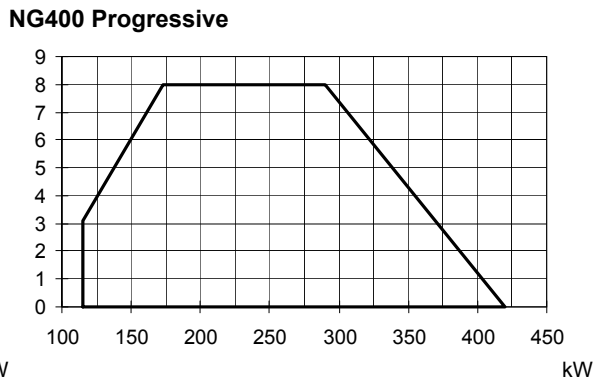
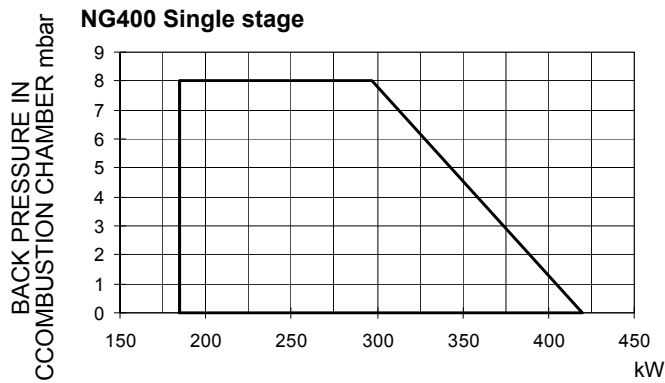
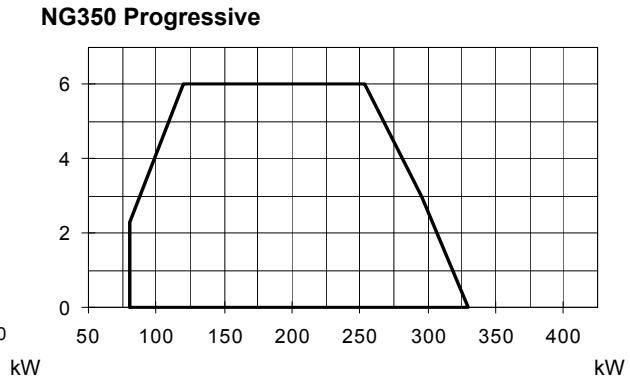
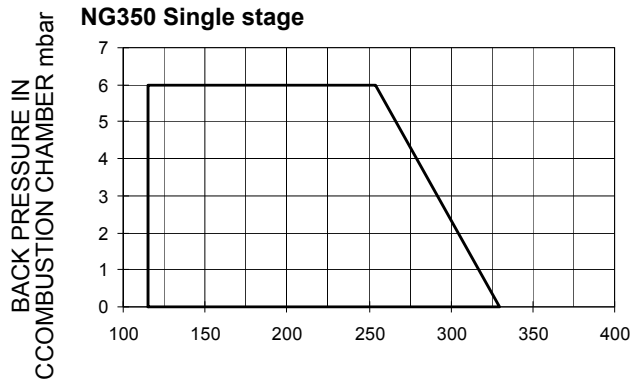
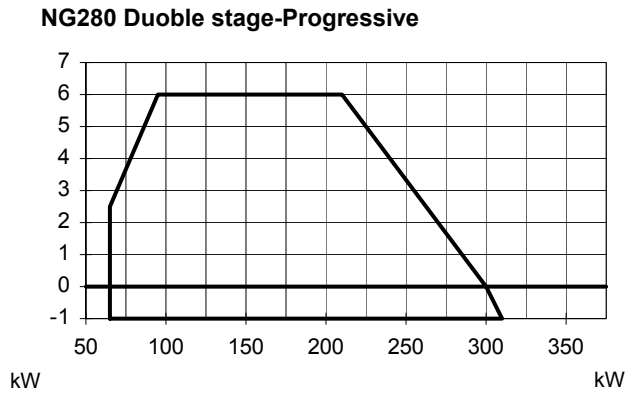
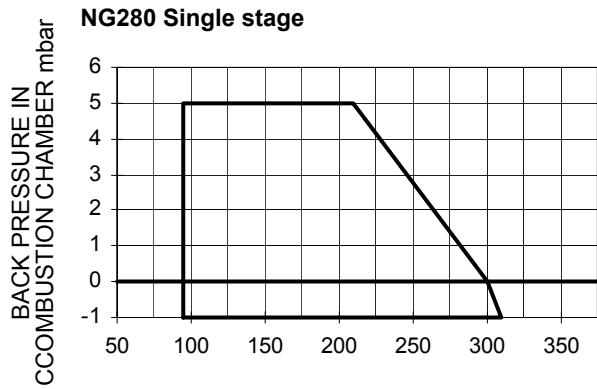

- L.P.G. Burners

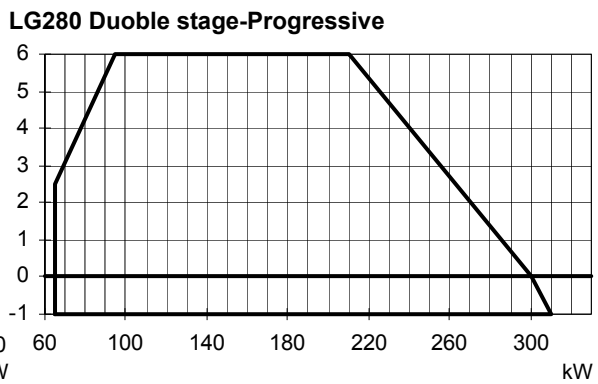
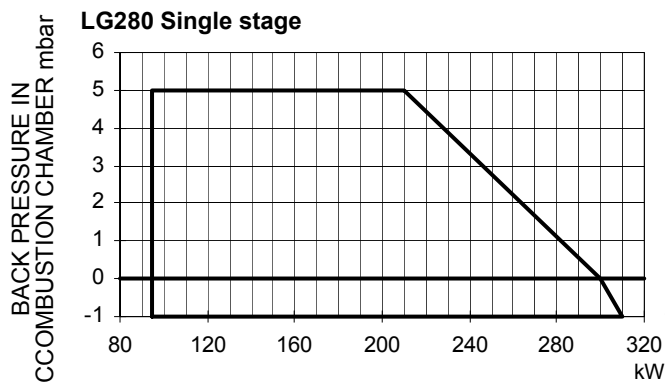

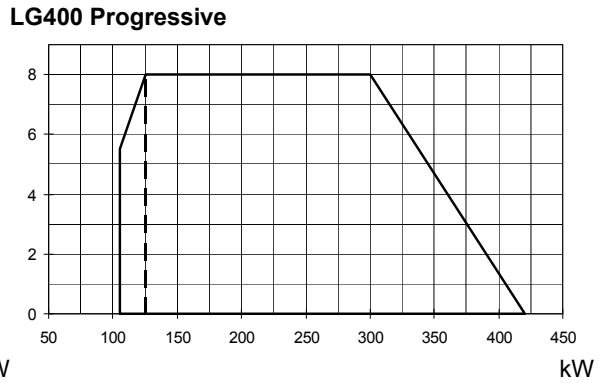
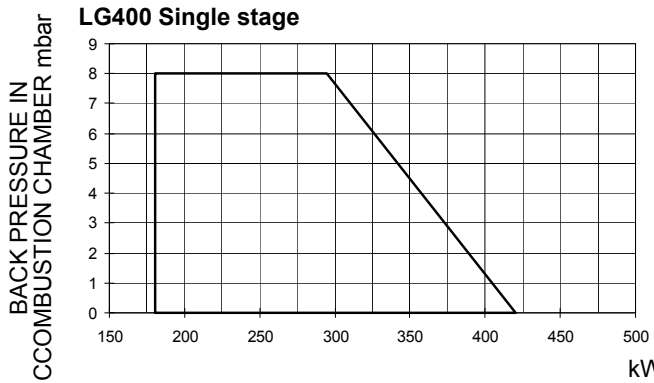
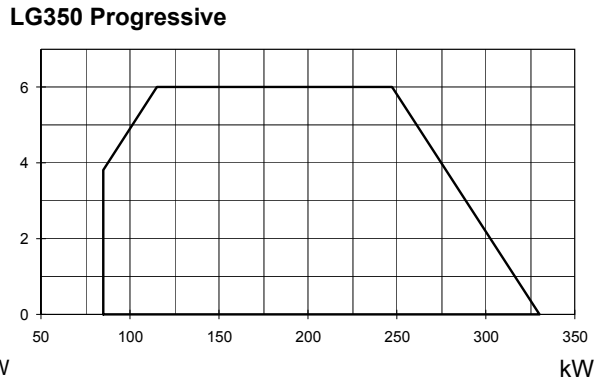
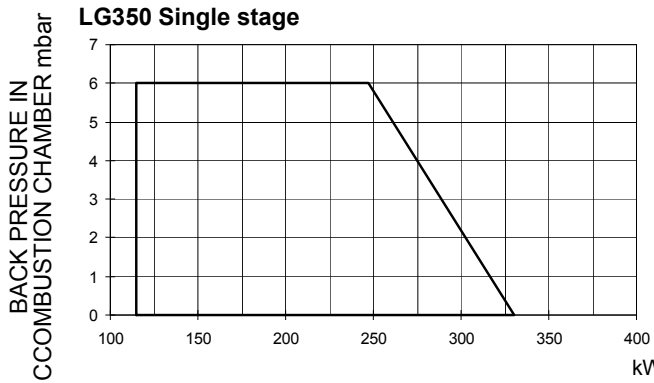

● **Low NOx burners**

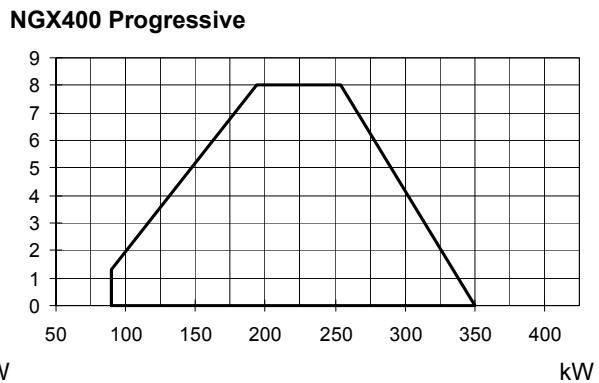
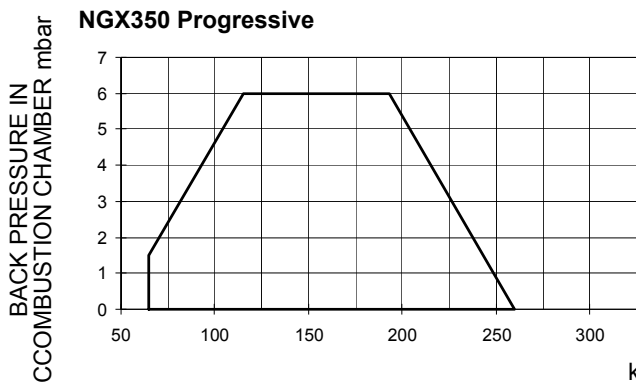
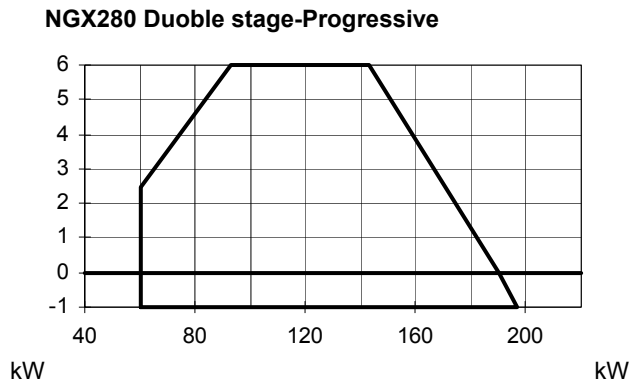
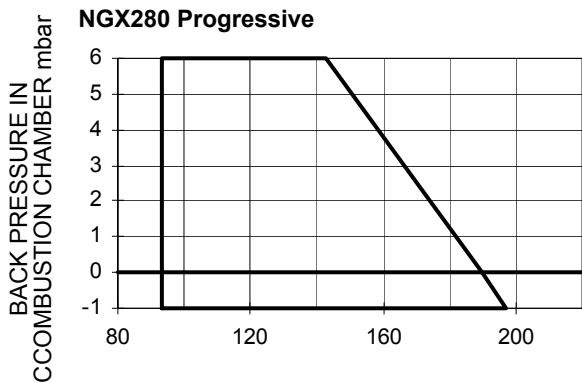

Data are referred to standard conditions: atmospheric pressure at 1013mbar, ambient temperature at 15°C.

NOTE: The performance curve is a diagram that represents the burner performance in the type approval phase or in the laboratory tests, but does not represent the regulation range of the machine. On this diagram the maximum output point is usually reached by adjusting the combustion head to its "MAX" position (see paragraph "Adjusting the combustion head"); the minimum output point is reached setting the combustion head to its "MIN" position. During the first ignition, the combustion head is set in order to find a compromise between the burner output and the generator specifications, that is why the minimum output may be different from the Performance curve minimum

Pressure in the network - gas flow rate curves

● **Gas burners**

NG280 M-.TN...

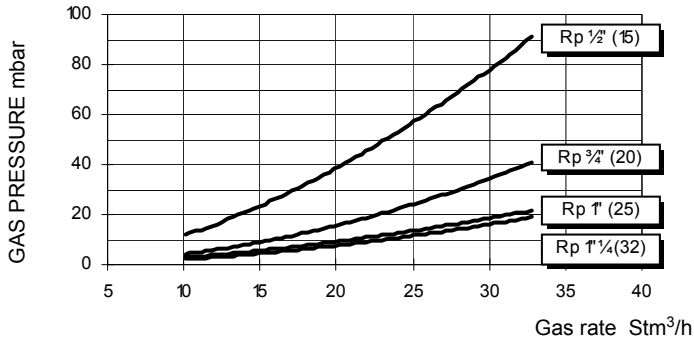

NG280 M-.xx...

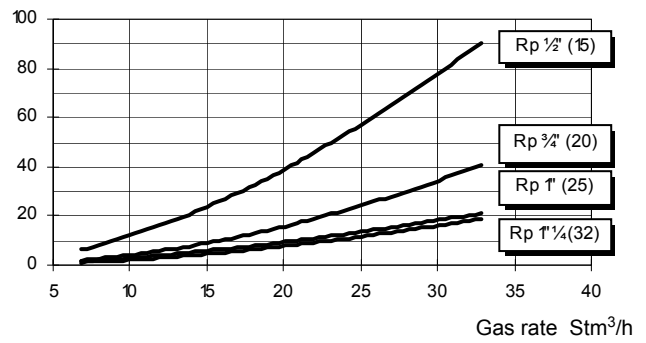

NG350 M-.TN...

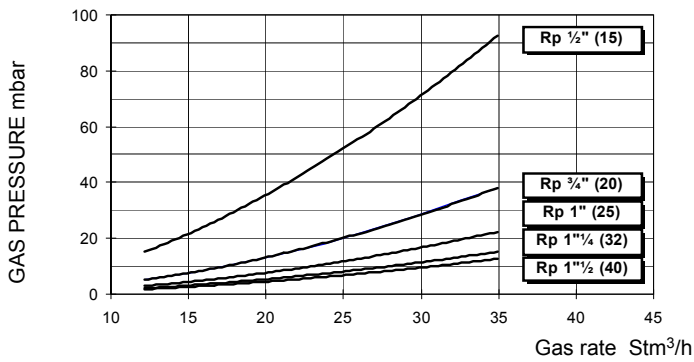

NG350 M-.PR/MD...

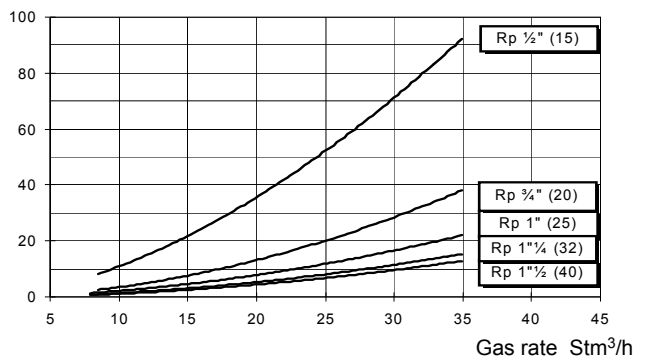

NG400 M-.TN..15-20-25

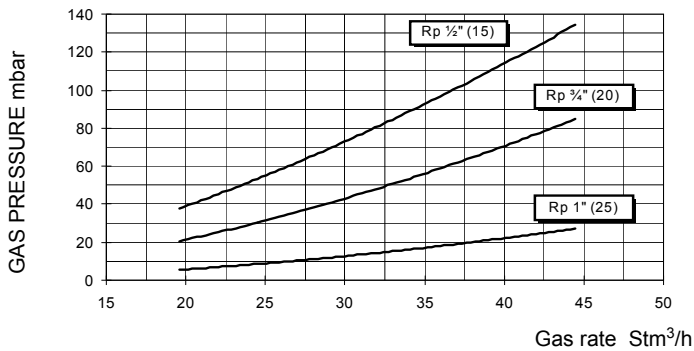

NG400 M-.TN..32-40-50

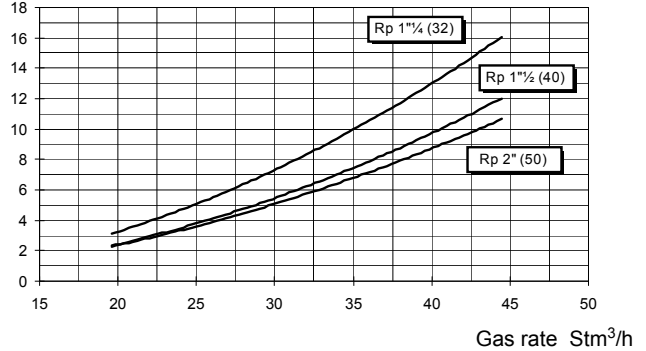

NG400 M-.PR/MD...15-20-25

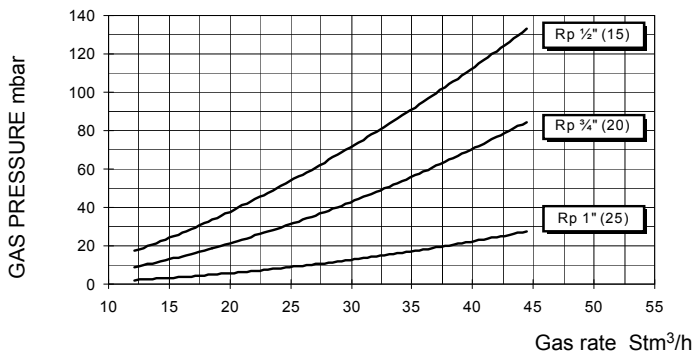

NG400 M-.PR/MD...32-40-50

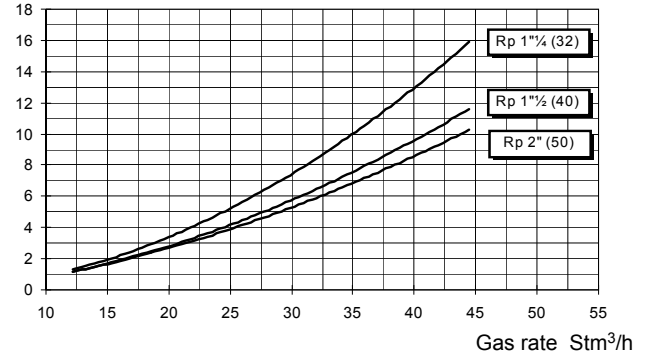

● **L.P.G. Burners**

LG280 L-.TN...

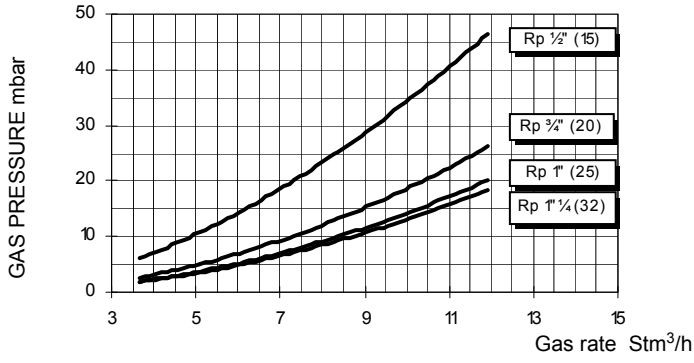

LG280 L-.xx...

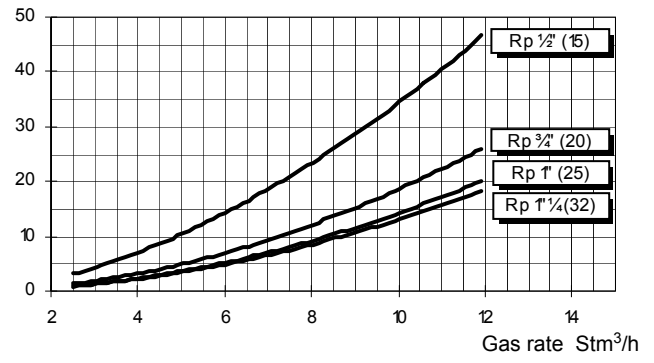

LG350 L-.TN...

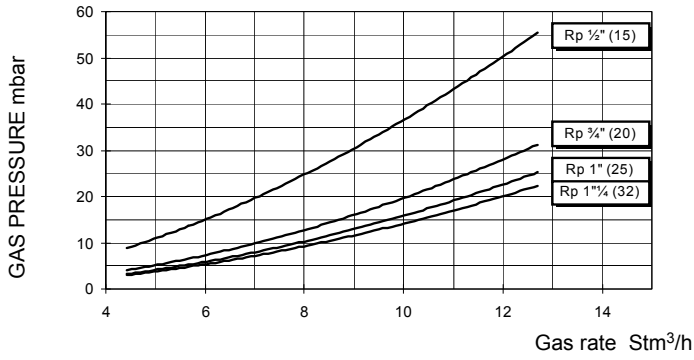

LG350 L-.PR/MD....

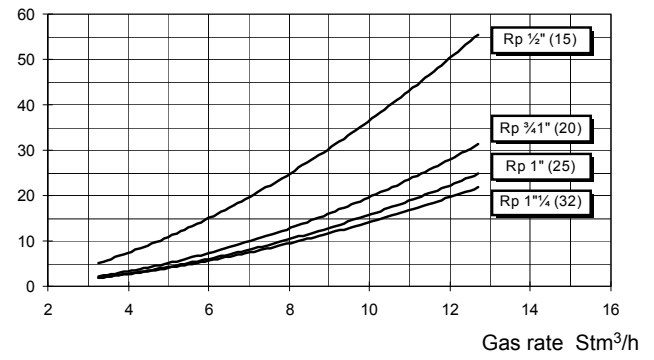

LG400 L-.TN...

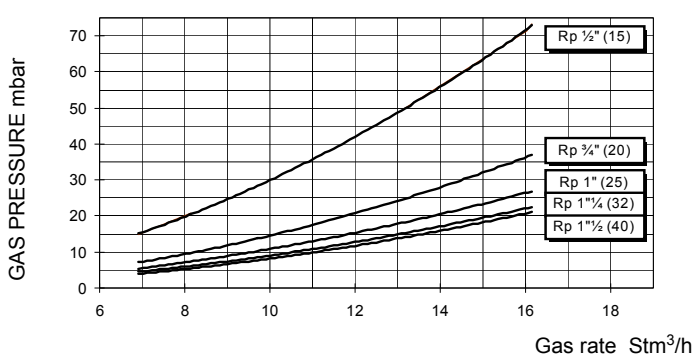

LG400 L-.PR/MD....

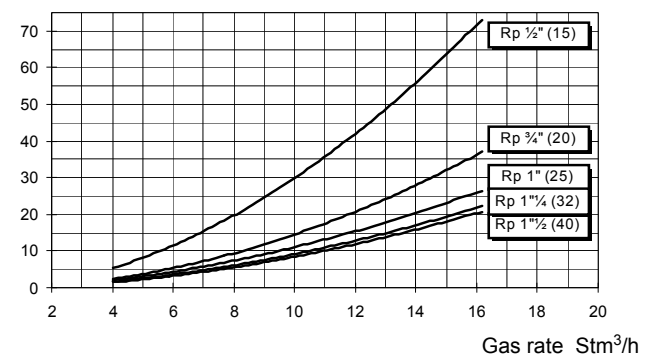

● Low NOx burners

NGX280 M-.TN..

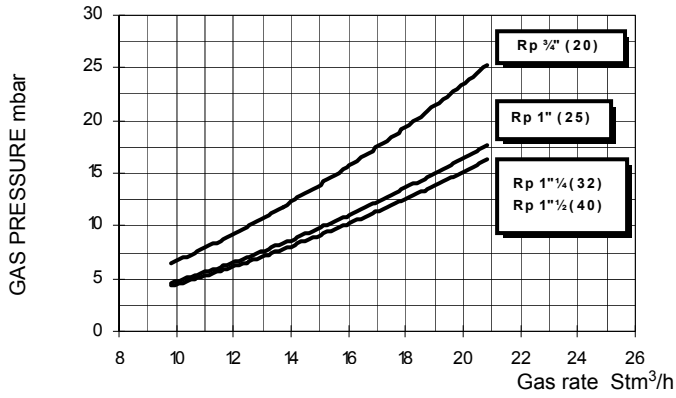

NGX280 M-.xx..

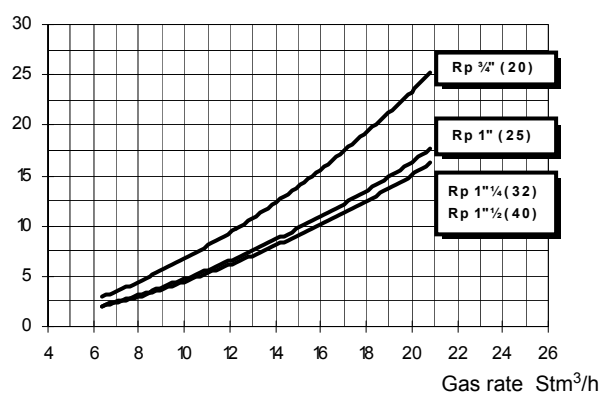

NGX350 Progressive

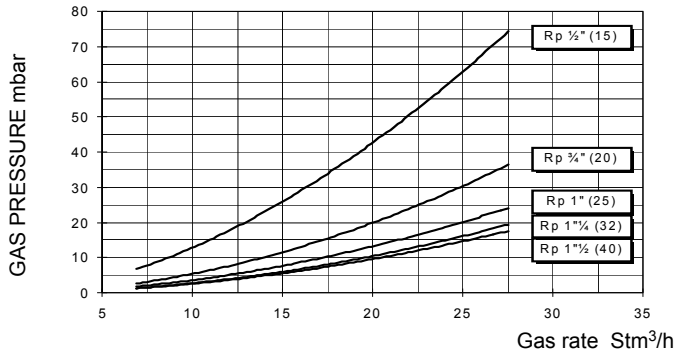

NGX400 M-...15-20-25

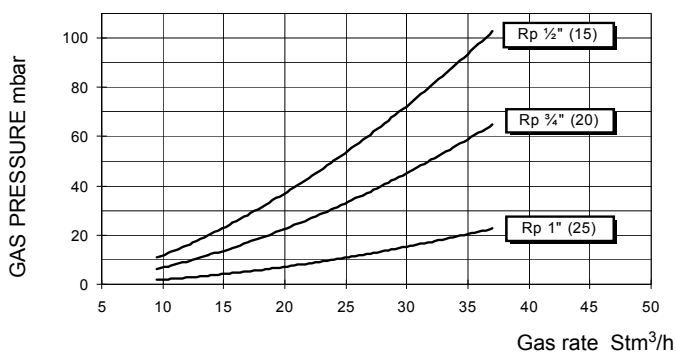

NGX400 M-...32-40-50

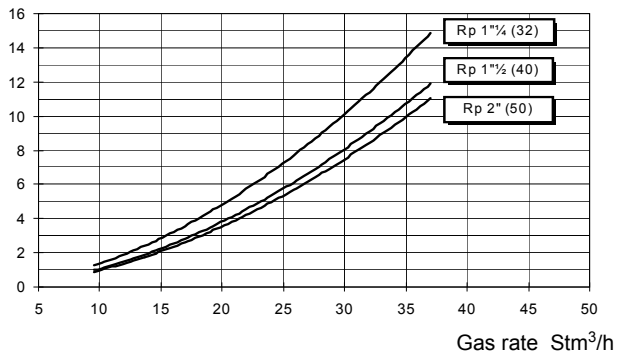

Caution: the gas rate value is quoted on the x-axis, the related network pressure is quoted on the y-axis (pressure value in the combustion chamber is not included). To know the minimum pressure at the gas train inlet, necessary to get the requested gas rate, add the pressure value in the combustion chamber to the value read on the y-axis.

Gas pressure curves in head vs. the flow rate

Curves are referred to pressure= 0mbar in the combustion head!

The curves referred to the gas pressure in head are referred to the burner properly set (percentage of residual O₂ in the flues as shown in the "Recommended combustion values" table and CO in the standard limits). To measure the pressure in the combustion chamber, as far as the IDEA series, a pressure plug is provided upstream the burner's blast tube.

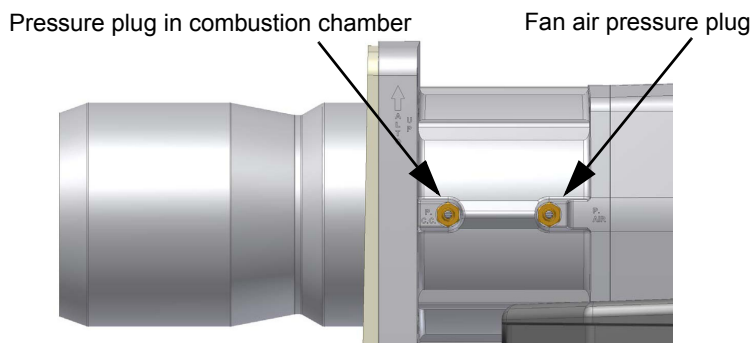

Fig. 1

Refer to Fig. 2, showing the correct way to measure the gas pressure, considering the values of pressure in combustion chamber, surveyed by means of the pressure gauge or taken from the boiler's Technical specifications. The measurement should be taken at the maximum output .

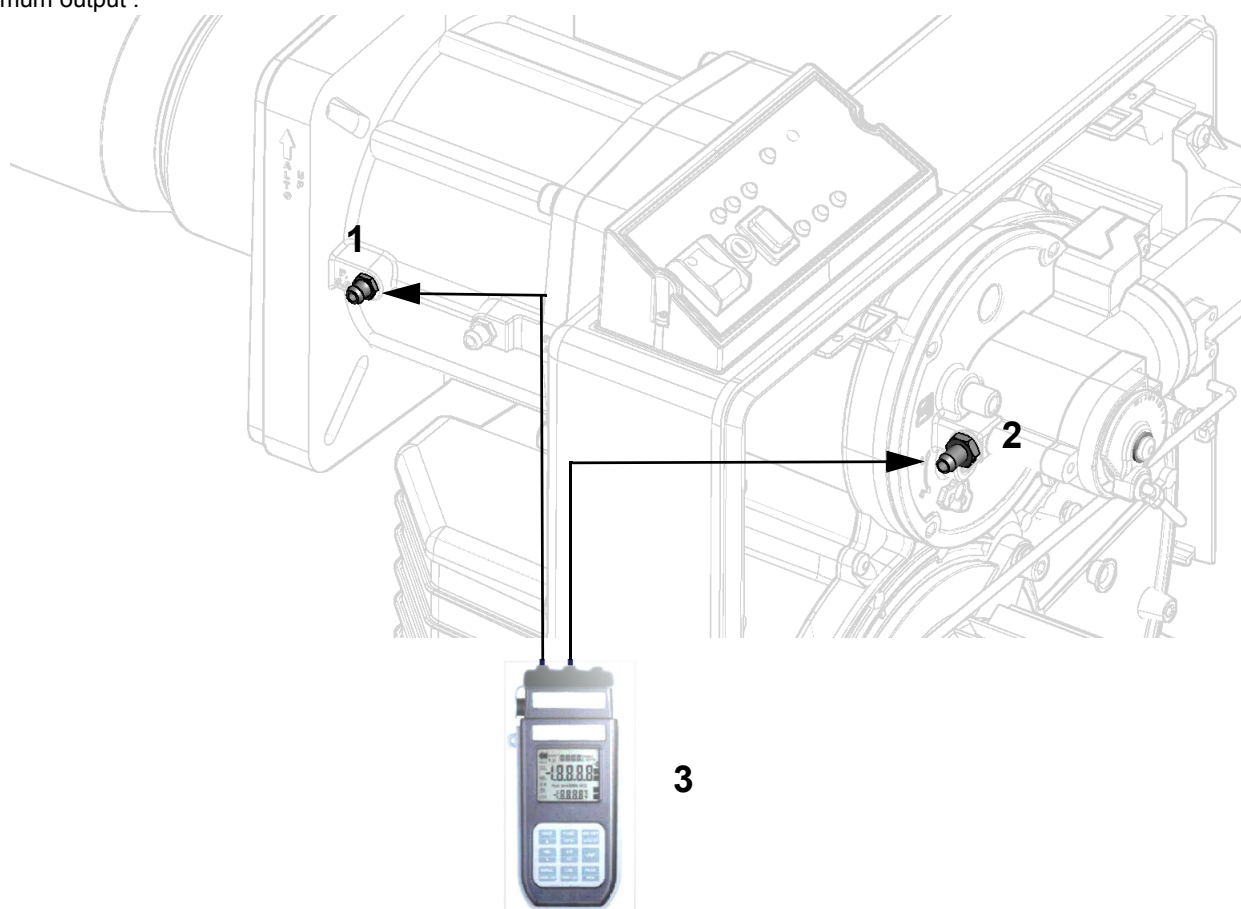

Fig. 2

Key

- 1 Pressure outlet on the combustion chamber
- 2 Gas pressure outlet on the butterfly valve
- 3 Differential pressure gauge

The differential pressure detected can be used with the graphs of the following paragraph in order to obtain the maximum flow rate of gas burned.(Stm³/h)**NOTE: THE PRESSURE-RATE CURVES ARE APPROXIMATE; FOR A PROPER SETTING OF THE GAS RATE, PLEASE REFER TO THE GAS METER READING.**

Pressure in the combustion head vs. gas flow rate curves

● **nNatural gas burners**

NG280 -

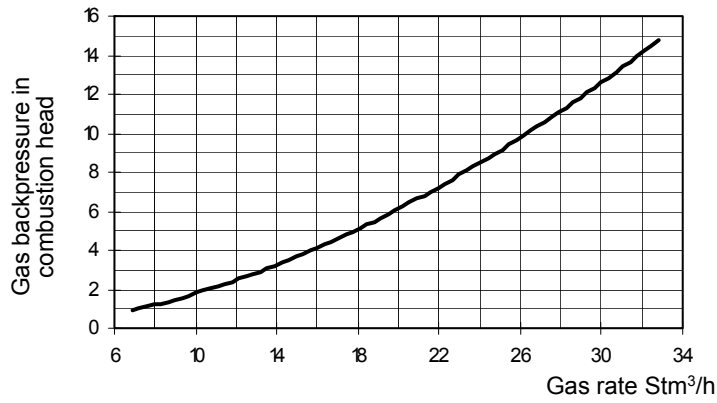

NG350 -

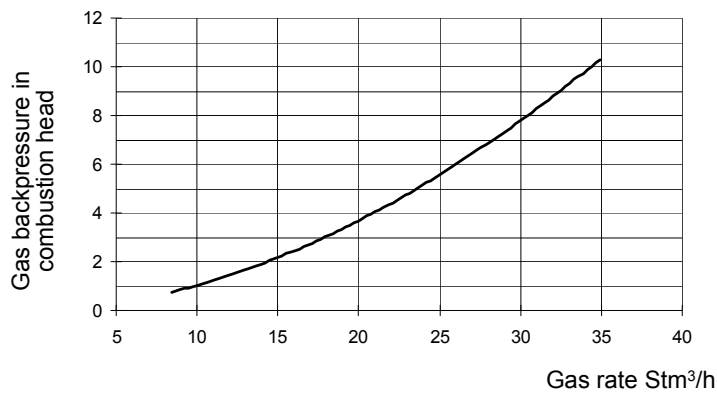

NG400 -

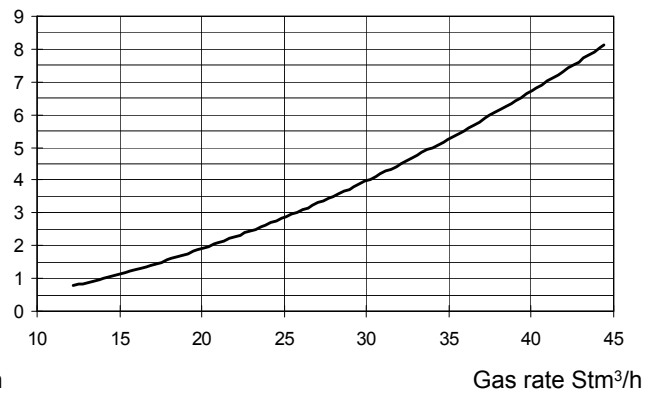

● **L.P.G. Burners**

LG280 -

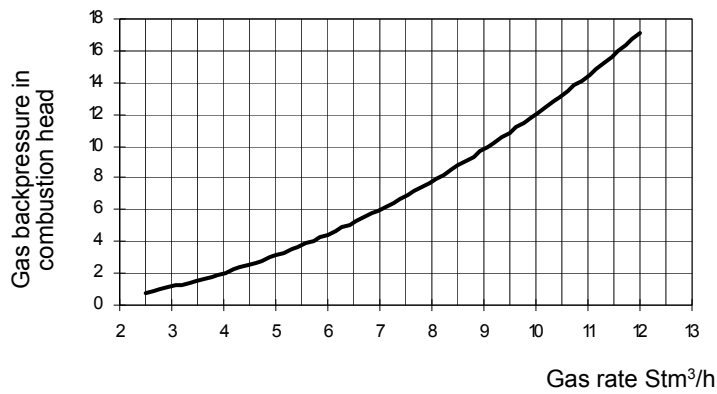

LG350 -

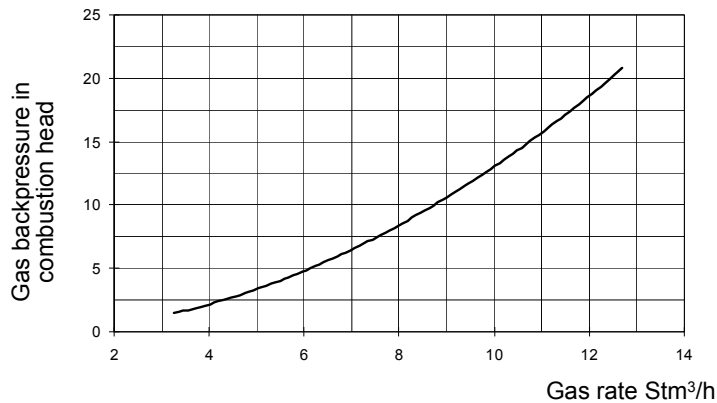

LG400 -

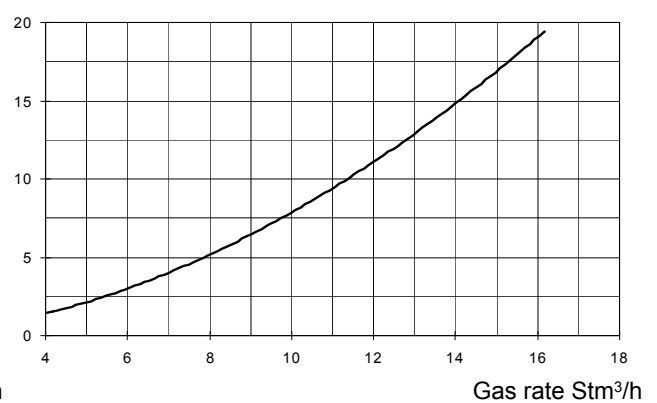

● Low NOx burners

NGX280

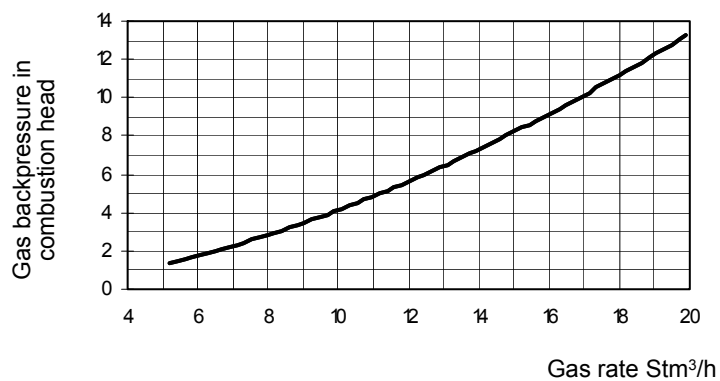

NGX350

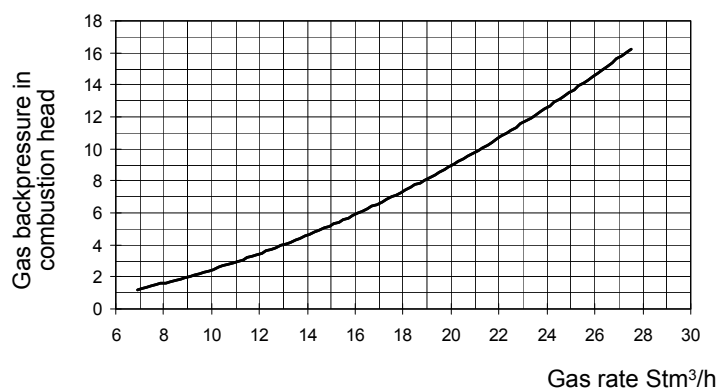

NGX400

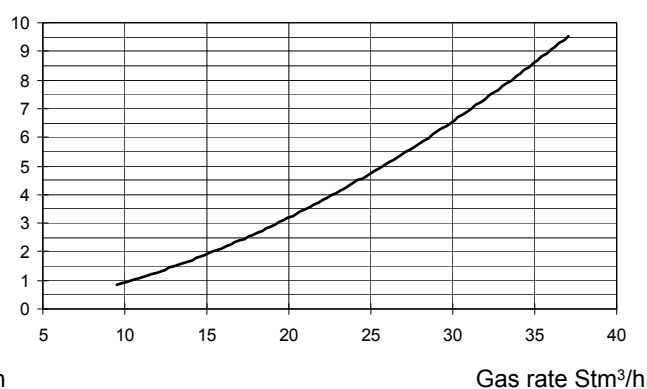

Overall dimensions (mm)

- *Standard burners*

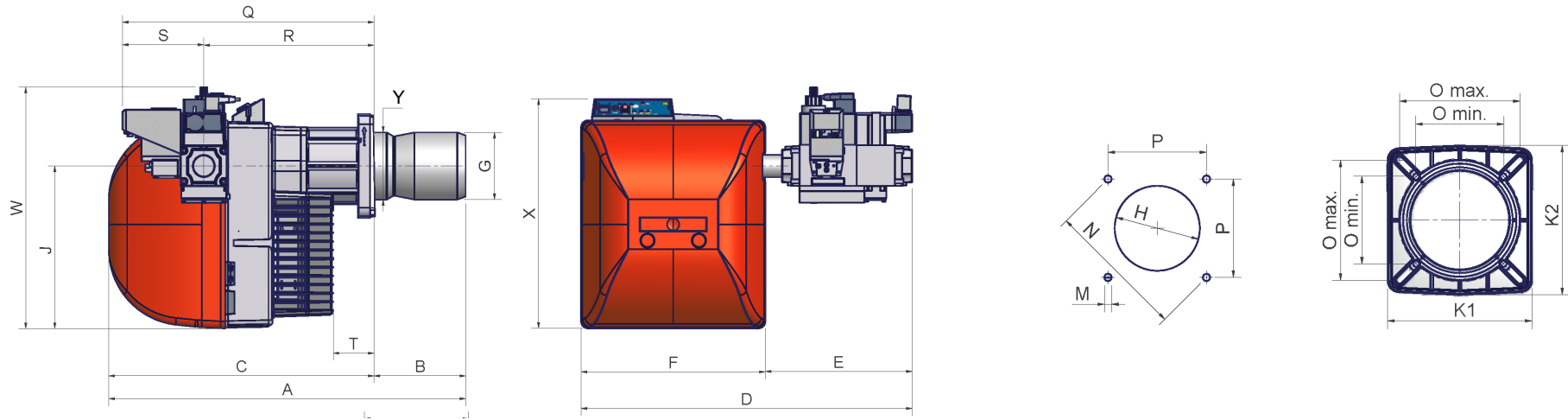

Recommended boiler drilling template and burner flange

	A(S*)	A(L)*	B(S*)	B(L)*	C	F	G	H	J	K1	K2	M	N	Omin	Omax	P	Q	R	S	T	X	Y
NG/LG280	733	878	163	308	570	396	117	137	348	215	223	M10	219	131	172	155	541	366	175	128	491	130
NG/LG350	748	878	178	308	570	396	125	164	348	215	223	M10	219	131	172	155	541	366	175	89	491	144
NG/LG400	768	898	198	328	570	396	144	164	348	215	223	M10	219	131	172	155	541	366	175	89	491	144

* S = measure referred to burners fitted with standard blast tube

L = measure referred to burners fitted with extended blast tube

Valves group dimensions according to gas train size.

	D ± 5 mm				E ± 5 mm				W			
	Rp 1	Rp 1 ¼	Rp 1 ½	Rp 2	Rp 1	Rp 1 ¼	Rp 1 ½	Rp 2	Rp 1	Rp 1 ¼	Rp 1 ½	Rp 2
NG/LG280	596	596	726	726	200	200	330	330	508	508	517	567
NG/LG350	596	596	726	726	200	200	330	330	508	508	517	567
NG/LG400	596	596	726	726	200	200	330	330	508	508	517	567

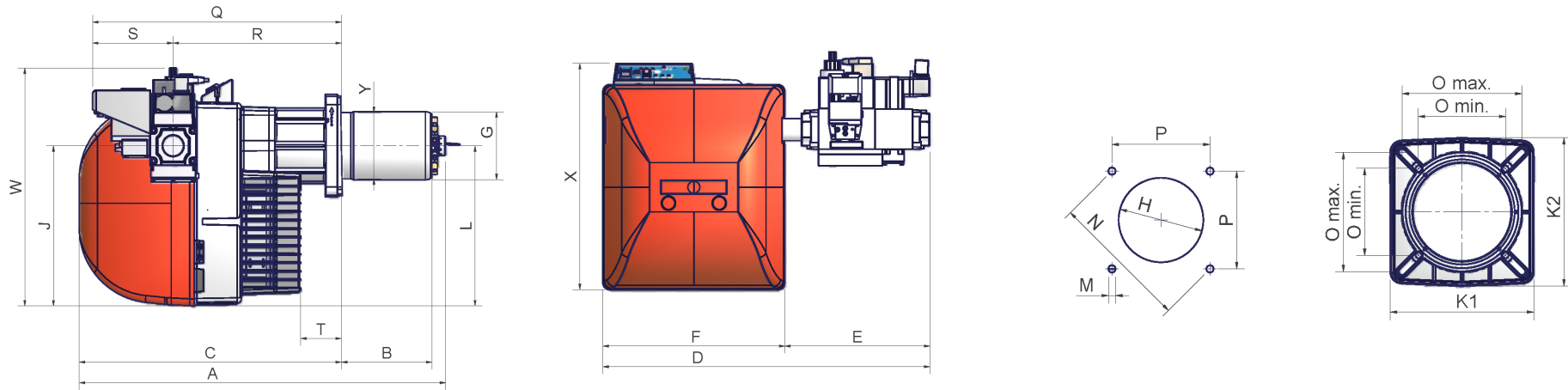

Recommended boiler drilling template and burner flange

	A(S*)	A(L)*	B(S*)	B(L)*	C	F	G	H	J	K1	K2	M	N	Omin	Omax	P	Q	R	S	T	X	Y
NGX280	733	878	163	308	570	396	114	137	348	215	223	M10	219	131	172	155	541	366	175	128	491	130
NGX350	748	878	178	308	570	396	137	164	348	215	223	M10	219	131	172	155	541	366	175	89	491	144
NGX400	768	898	198	328	570	396	156	176	348	215	223	M10	219	131	172	155	541	366	175	89	491	156

* S = measure referred to burners fitted with standard blast tube

L = measure referred to burners fitted with extended blast tube

Valves group dimensions according to gas train size.

	D ± 5 mm				E ± 5 mm				W			
	Rp 1	Rp 1 ¼	Rp 1 ½	Rp 2	Rp 1	Rp 1 ¼	Rp 1 ½	Rp 2	Rp 1	Rp 1 ¼	Rp 1 ½	Rp 2
NGX280	596	596	726	726	200	200	330	330	508	508	517	567
NGX350	596	596	726	726	200	200	330	330	508	508	517	567
NGX400	596	596	726	726	200	200	330	330	508	508	517	567

PART II: INSTALLATION

MOUNTINGS AND CONNECTIONS**Packing**

The burners are despatched in cardboard packages whose dimensions are: 800mm x 540mm x 480mm (L x P x H)

Packing cases of this type are affected by humidity; the maximum number of cases to be stacked is indicated outside the packing.

The following are placed in each packing case.

- Burner with gas train;
- gasket to be inserted between the burner and the boiler;
- envelope containing tis manual

When disposing of the burner packing and if the packing is scrapped follow the procedures laid down in the current legislation regarding the disposal of materials.

Fitting the burner to the boiler

To install the burner into the boiler, proceed as follows:

- 1 make a hole on the closing door of the combustion chamber as described on paragraph "Overall dimensions")
- 2 place the burner to the boiler: lift it up and handle it according to the procedure described on paragraph "Handling the burner";
- 3 place the stud bolts (5) on boiler's door, according to the burner drilling template described on paragraph "Overall dimensions";
- 4 fasten the stud bolts;
- 5 place the gasket on the burner flange;
- 6 install the burner into the boiler;
- 7 fix the burner to the stud bolts, by means of the fixing nuts, according to the next picture.
- 8 After fitting the burner to the boiler, ensure that the gap between the blast tube and the refractory lining is sealed with appropriate insulating material (ceramic fibre cord or refractory cement).

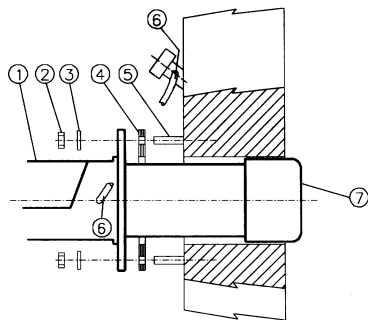
**Keys**

- | | |
|---|----------------|
| 1 | Burner |
| 2 | Fixing nut |
| 3 | Washer |
| 4 | Sealing gasket |
| 5 | Stud bolt |
| 7 | Blast tube |

To install the burner gasket proceed as shown by the following images.

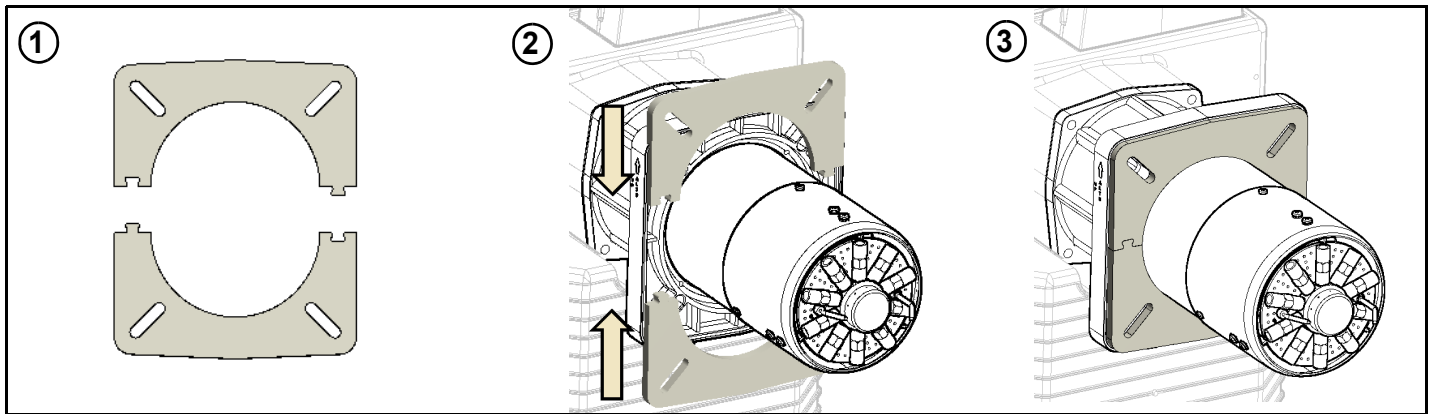

Matching the burner to the boiler

The burners described in this manual have been tested with combustion chambers that comply with EN676 regulation and whose dimensions are described in the diagram. In case the burner must be coupled with boilers with a combustion chamber smaller in diameter or shorter than those described in the diagram, please contact the supplier, to verify that a correct matching is possible, with respect of the application involved. To correctly match the burner to the boiler verify the necessary input and the pressure in combustion chamber are included in the burner performance curve; otherwise the choice of the burner must be revised consulting the burner manufacturer. To choose the blast tube length follow the instructions of the boiler manufacturer. In absence of these consider the following:

- Cast-iron boilers, three pass flue boilers (with the first pass in the rear part): the blast tube must protrude no more than 100 mm into the combustion chamber.
- Pressurised boilers with flame reversal: in this case the blast tube must penetrate at least 50 - 100 mm into combustion chamber in respect to the tube bundle plate.

The length of the blast tubes does not always allow this requirement to be met, and thus it may be necessary to use a suitably-sized spacer to move the burner backwards or to design a blast tube that suits the utilisation (please, contact the manufacturer).

Key

- a) Heat output in kW
- b) Length of the flame tube in meters
- c) Flame tube firing intensity in MW/m³
- d) Combustion chamber diameter (m)

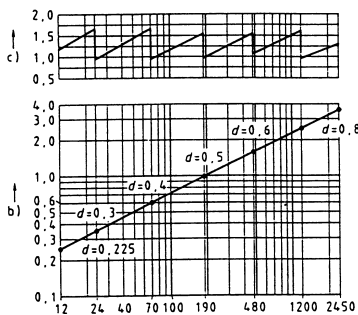

Fig. 3

How to modify the blast tube length (NG/LG350-NG/LG400)

To modify blast tube length please read the following instructions.

- 1 Remove combustion head (See “Removing the combustion head” - Part III of this user’s guide).
- 2 Remove the flanged piece **T** by removing the 4 socket head screws **VTF** (Fig. 4).
- 3 Remove the 4 screws which hold the blast tube to the flanged piece (Fig. 5).
- 4 Extract the blast tube from the flanged piece and assemble it in the other way round as shown in pictures Fig. 6 and Fig. 7. Now fasten the two pieces using the same screws.
- 5 Assemble the whole piece to the burner by caring attention to the indication in picture Fig. 9.

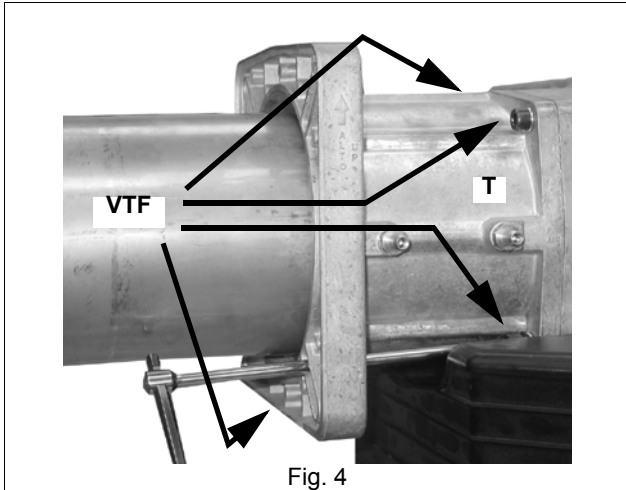

Fig. 4

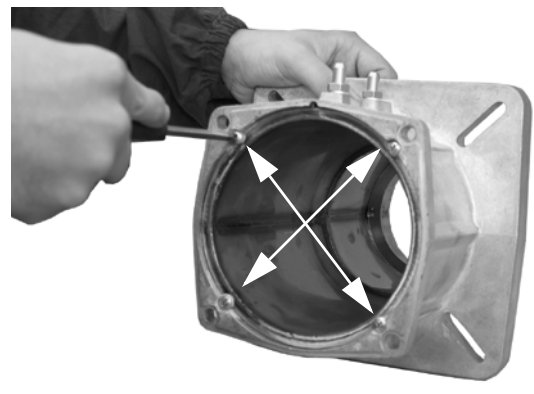

Fig. 5

Fig. 6 - Short blast tube

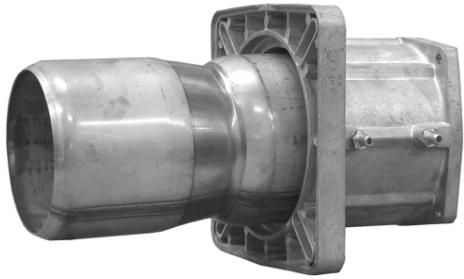

Fig. 7 - Long blast tube

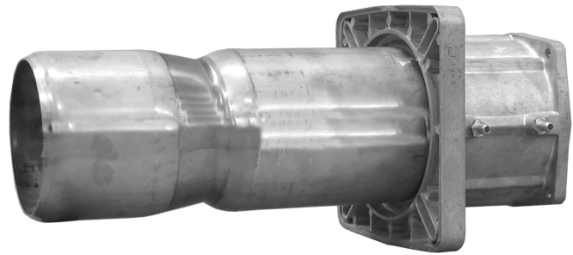
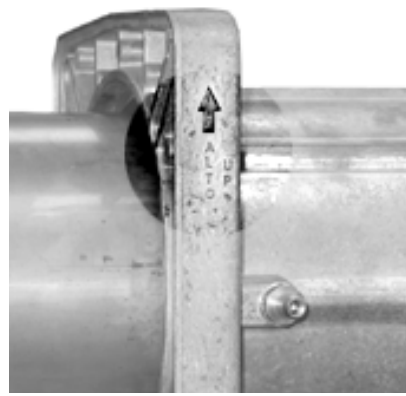

Fig. 8



Fig. 9



If you modify the blast tube length you have to modify also the combustion head length by reading the following instructions.

- 1 Remove the screws **V1** and **V2** as shown in Fig. 10.
- 2 Lower the terminal part of the combustion head, by moving it with a slight circular movement, until the holes will match (Fig. 11) and tight the screw shown in Fig. 12.
- 3 Adjust cables length by pulling them very slightly paying particular attention not to disconnect the ionisation cable to the electrode.
- 4 Fix the combustion head again (See "Removing the combustion head").

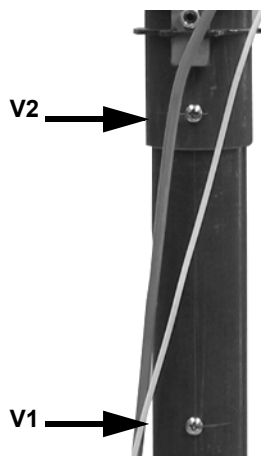

Fig. 10

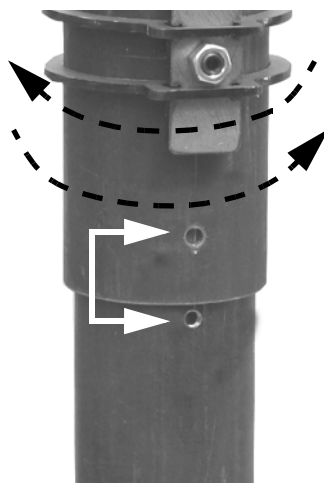

Fig. 11

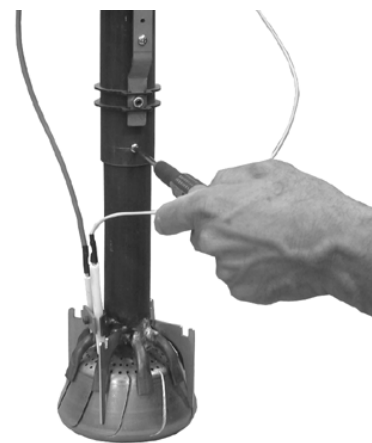

Fig. 12

Gas Train Reversal

The gas train can be fit either on the left and on the right. Follow these instruction..

- 1 Remove the plastic hook **G** to release the rod **T** (Fig. 13) .
- 2 Take the screws **V1**, **V2**, **V3**, **V4**, **VT1** and **VT2** off (Fig. 13).
- 3 Take the ignition cable **CA** off of the transformer .
- 4 Disconnect the connector **CR** from the printed circuit (Fig. 14).
- 5 Take off the flange and the combustion head together (Fig. 16).
- 6 Take the gas pipe **TR** off and put it in the new position fixing the screws **VT1** and **VT2** (Fig. 15).

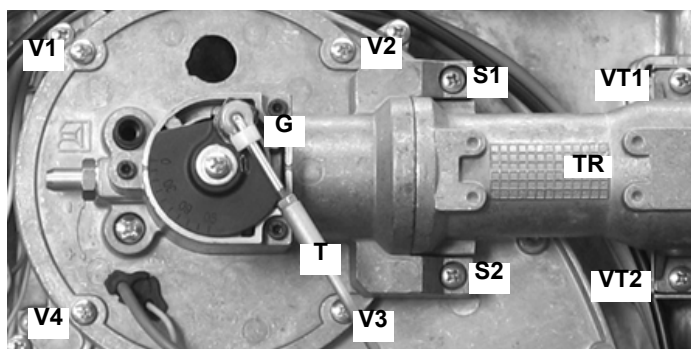

Fig. 13

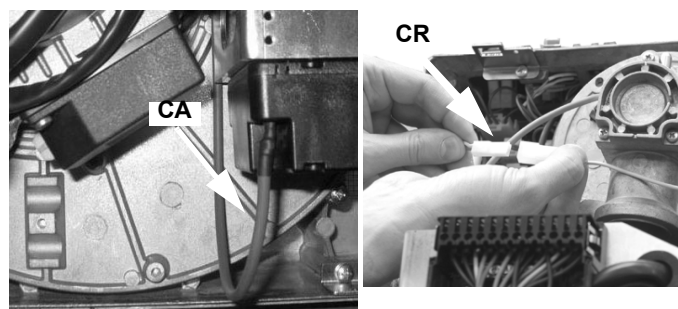
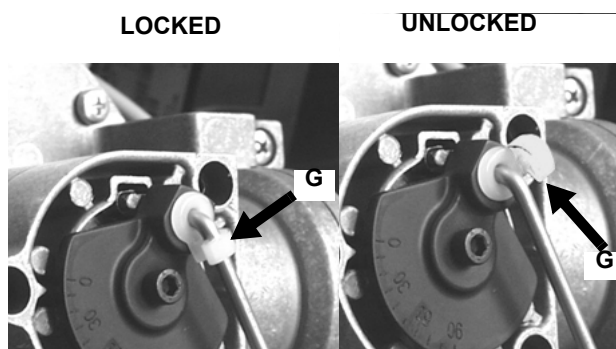

Fig. 14

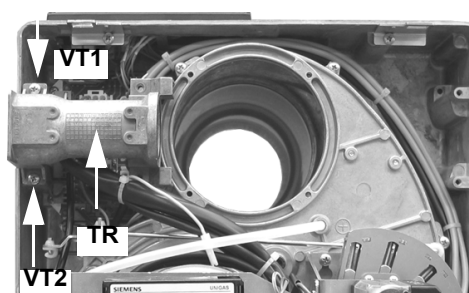

Fig. 15

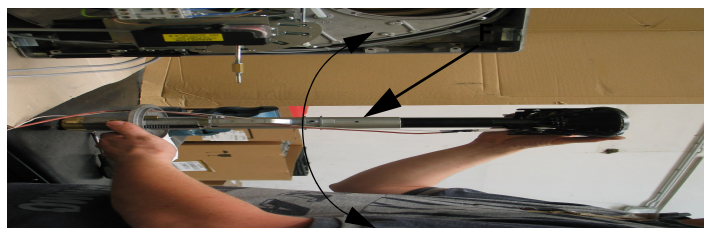

Fig. 16

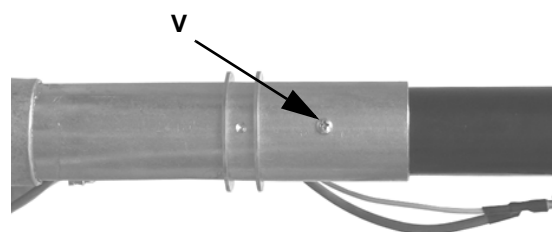

Fig. 17

- 7 Unscrew the **V**, rotate the head of 180 ° along its axis as shown in(Fig. 16), until the hole **F** is found. Fit the screw again(Fig. 16 - Fig. 17).

- 8 (Fig. 18) Insert again the flange and the combustion head together
- 9 (Fig. 18) Rotate the disc **D** following the instructions below.
- 10 Take off the screw **VF**.(Fig. 18)
- 11 Rotate the disc **D** for 180 ° and then fit the screw **VF** (Fig. 19).

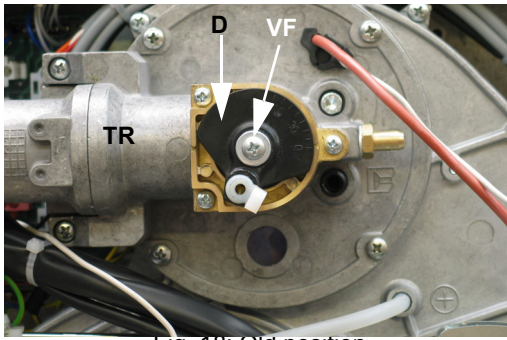

Fig. 18: Old position

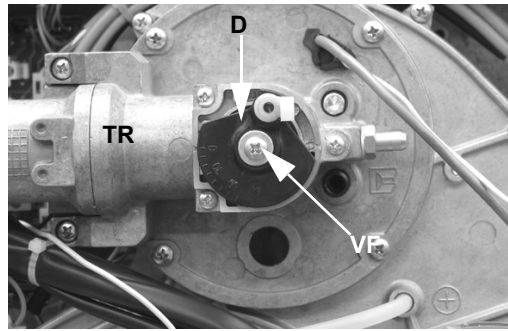

Fig. 19: New position

- 12 Reconnect **CR** and **CA**.
- 13 Retighten the screws **V1**, **V2**, **V3**, **V4**, **VT1** e **VT2**
- 14 Place again the rod **T** into its own position and fasten it by the plastic hook **G**.

GAS TRAIN CONNECTIONS

This paragraph shows the gas train components which are included in the delivery and those which must be fitted by the customer. The diagram complies with regulations in force



ATTENTION: BEFORE EXECUTING THE CONNECTIONS TO THE GAS PIPE NETWORK, BE SURE THAT THE MANUAL CUTOFF VALVES ARE CLOSED. READ CAREFULLY THE "WARNINGS" CHAPTER AT THE BEGINNING OF THIS MANUAL.

Gas train with valves group MB-DLE (2 valves + gas filter + pressure governor) + VPS504 gas proving system

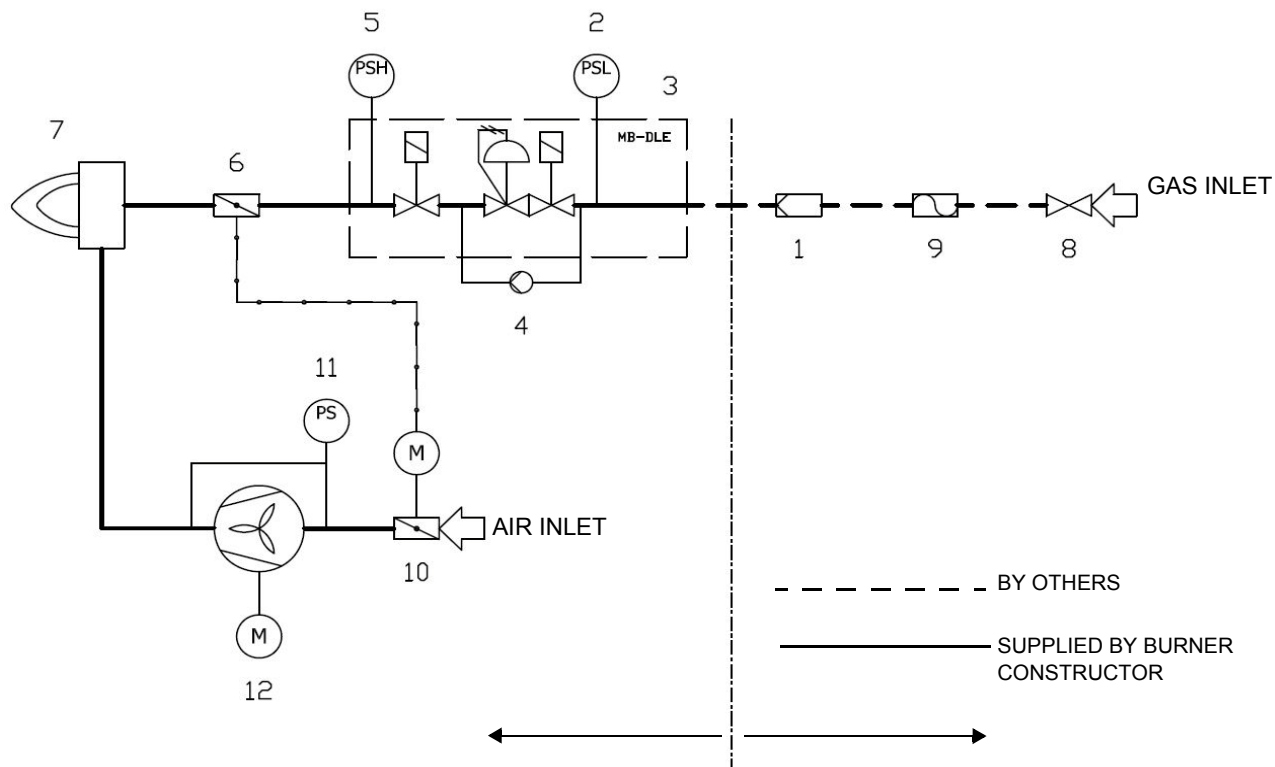

Key

MAIN GAS TRAIN		COMBUSTION AIR TRAIN	
1	Filter	10	Air damper with actuator
2	Pressure switch - PGMIN	11	Pressure switch - PA
3	Safety valve with built in gas governor	12	Draught fan with electromotor
4	Proving system		
5	Pressure switch - PGMAX(*)		
6	Butterfly valve		
7	Main burner		
8	Manual valve(*)		
9	Bellows unit(*)		

*Note: the maximum gas pressure switch can be mounted either upstream or downstream the gas valve but upstream the butterfly gas valve (see item no.4 in the scheme above).

To mount the gas train, proceed as follows:

- 1) in case of threaded joints: use proper seals according to the gas used;
- 2) fasten all the items by means of screws, according to the next diagrams, observing the mounting direction for each item.

NOTE: the bellow joint, the manual valve and the gaskets are not part of the standard supply.

The procedures of installation for the gas valves are shown in the next paragraph.



ATTENTION: once the gas train is mounted according to the diagram, the gas proving test must be performed, according to the procedure set by the laws in force.



ATTENTION: it is recommended to mount filter and gas valves to avoid that extraneous material drops inside the valves, during maintenance and cleaning operation of the filters (both the filters outside the valves group and the ones built-in the gas valves).

MULTIBLOC DUNGS MB-DLE 405..412

Mounting

1. Mount flange onto tube lines: use appropriate sealing agent (see Fig. 22);
2. insert MB-DLE: note position of O rings (see Fig. 22);
3. tighten screws A, B, C and D (Fig. 20 - Fig. 21), according to the mounting positions (Fig. 23);
4. after installation, perform leakage and functional test;
5. disassembly in reverse order.

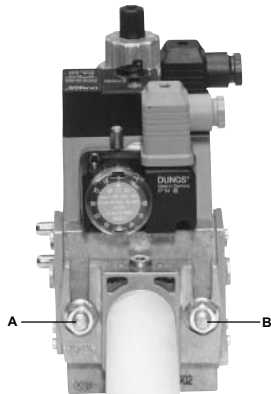

Fig. 20

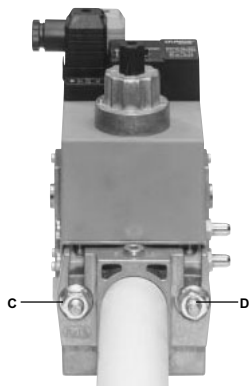

Fig. 21

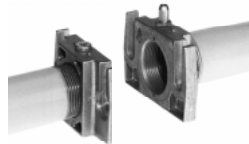

Fig. 22

MOUNTING POSITIONS

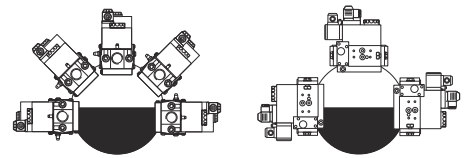

Fig. 23

MULTIBLOC DUNGS MB-DLE 415..420

Mounting

1. Loosen screws A and B **do not** unscrew (Fig. 20 - Fig. 21).
2. unscrew screws C and D (Fig. 20 - Fig. 21).
3. Remove MultiBloc between the threaded flanges (Fig. 21).
4. After mounting, perform leakage and functional tests.

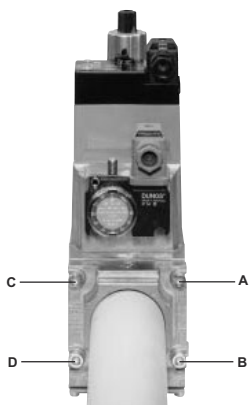

Fig. 24

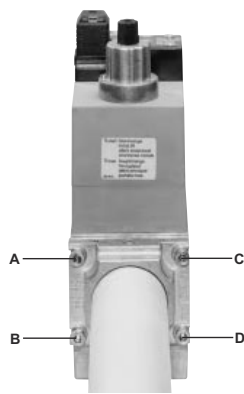

Fig. 25

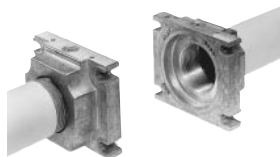

Fig. 26

MOUNTING POSITIONS

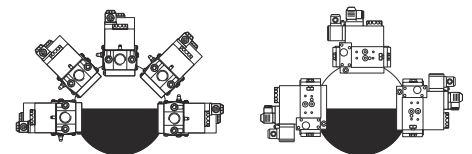

Fig. 27

Once the train is installed, connect the gas valves group plug



ATTENTION: once the gas train is mounted according to the diagram, the gas proving test must be performed, according to the procedure set by the laws in force.

ELECTRICAL CONNECTIONS

WARNING: if the cable that connects the thermostats and the control box should be longer than 3 meters, insert a sectioning relay following the attached electrical wiring diagram.



RESPECT THE BASIC SAFETY RULES. MAKE SURE OF THE CONNECTION TO THE EARTHING SYSTEM. DO NOT REVERSE THE PHASE AND NEUTRAL CONNECTIONS. FIT A DIFFERENTIAL THERMAL MAGNET SWITCH ADEQUATE FOR CONNECTION TO THE MAINS.

ATTENTION: before executing the electrical connections, pay attention to turn the plant's switch to OFF and be sure that the burner's main switch is in 0 position (OFF) too. Read carefully the chapter "WARNINGS", and the "Electrical connections" section.

To execute the electrical connections, proceed as follows:

- 1 find the plug or the plugs, according to the model, that comes out from the burner:
 - 7 pins plug for the power supply (for all models);
 - 4 pins plug (for AB - double stage, PR-progressive, MD - fully-modulating);
 - 3-pins plug (only for NG/LG/NGX400);
- 2 execute the electrical connections to the plugs, according to the burner model (see next paragraph);
- 3 once all the connections are accomplished, check the fan motor direction (see next paragraphs);
- 4 now the burner is ready to start up.



The burner is fitted with a bridge between terminals T6 and T8 on the 4-poles plug-TAB (external side link, male connector); if the TAB high/low flame thermostat must be connected, remove the bridge between terminals, before connecting the thermostat.



WARNING: before operating the burner, be sure all connectors are linked as shown in the diagrams.

Connectors identification

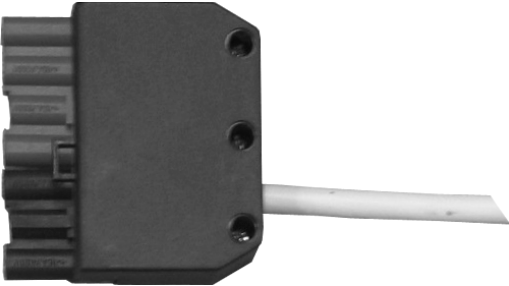
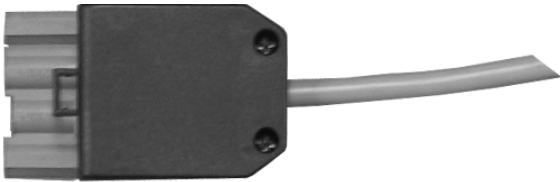
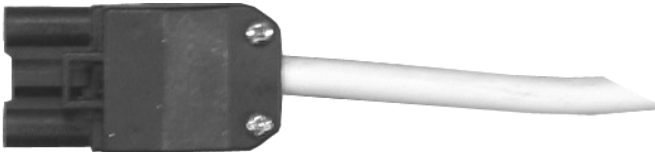
<p>Burner power supply connector (Fig. 31 - Fig. 33 - Fig. 35)</p> <p>Probe connection connector (fully modulating burners, Fig. 37)</p>	 <p style="text-align: right;">Fig. 28</p>
<p>HIGH/LOW flame connector (progressive burners, Fig. 33)</p>	 <p style="text-align: right;">Fig. 29</p>
<p>Fan motor connector (NG/NGX400 only) (Fig. 32 - Fig. 36)</p>	 <p style="text-align: right;">Fig. 30</p>

Connectors wiring diagrams

● **Single stage burner's connectors:**

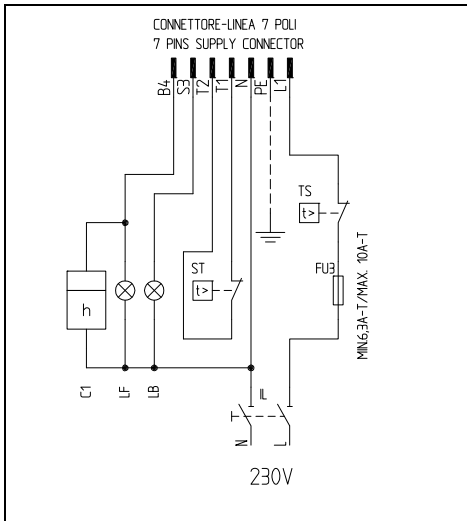

Fig. 31 - 7-pins connector

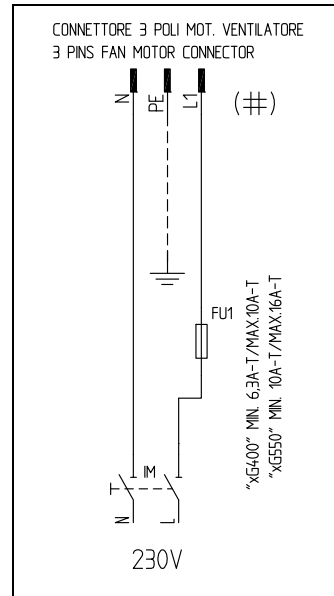

Fig. 32 - Electric motor's 3-pins connector
NG/LG/NGX400

● **Progressive burners' connectors:**

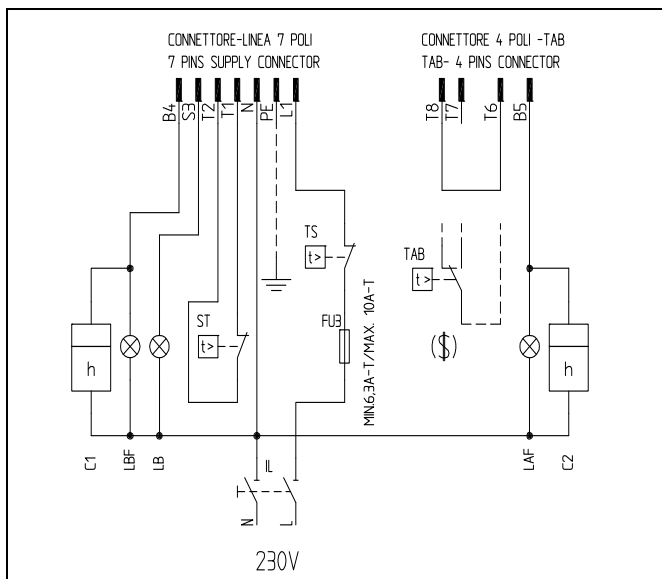

Fig. 33 - 7-pin and 4-pin connectors

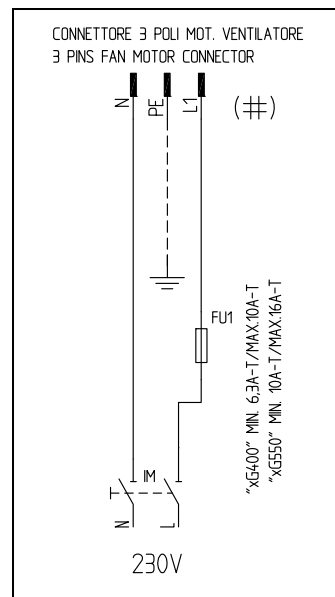

Fig. 34 Electric motor's 3-pin connector for
NG/LG/NGX400

Key

- C1 LOW FLAME TIME METER
- C2 HIGH FLAME TIME METER
- FU1 FAN MOTOR LINE FUSE
- FU3 LINE FUSE
- IL BURNER LINE SWITCH
- IM FAN MOTOR LINE SWITCH
- KM1 FAN MOTOR CONTACTOR
- LAF BURNER IN HIGH FLAME INDICATOR LIGHT
- LB INDICATOR LIGHT FOR BURNER LOCK-OUT

- LBF BURNER IN LOW FLAME SIGNALLING LAMP
 - MV FAN MOTOR
 - ST THERMOSTATS O PRESSURE SWITCHES SERIE
 - TAB HIGH LOW FLAME THERMOSTAT/PRESSURE SWITCH
 - TS SAFETY THERMOSTAT/PRESSURE SWITCH
 - CONN-MOTORE FAN MOTOR CONNECTOR
 - CONN-LINEA BURNER POWER SUPPLY CONNNECTOR
 - CONN-TAB HIGH-LOW FLAME CONNECTOR
- (\$) IF "TAB" USED REMOVE THE BRIDGE BETWEEN TERMINALS T6-T8

● Fully-modulating burners' connectors:

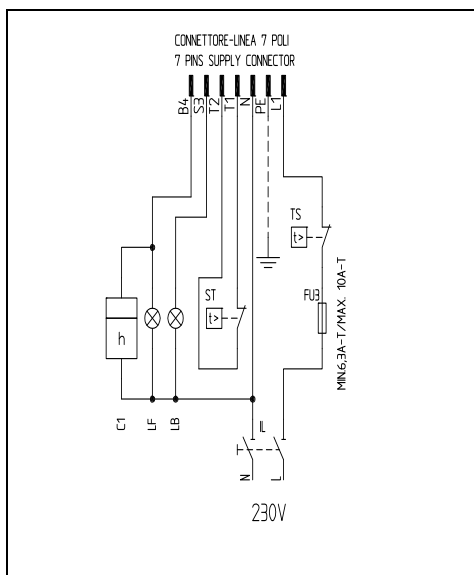

Fig. 35 - 7-pin connector

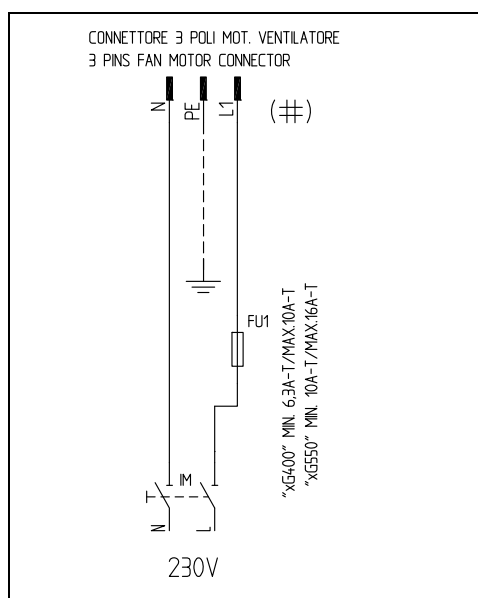

Fig. 36 - Electric motor's 3-pin connector for NG/LG/NGXG400

Key

- C1 LOW FLAME TIME METER
- FU1 LINE FUSE FOR FAN MOTOR
- FU3 LINE FUSE
- FU4 AUXILIARY FUSE
- IL BURNER LINE SWITCH
- IM FAN MOTOR LINE SWITCH
- KM1 FAN MOTOR REMOTE CONTACTOR
- LANDIS RWF40 MODULATION REGULATOR

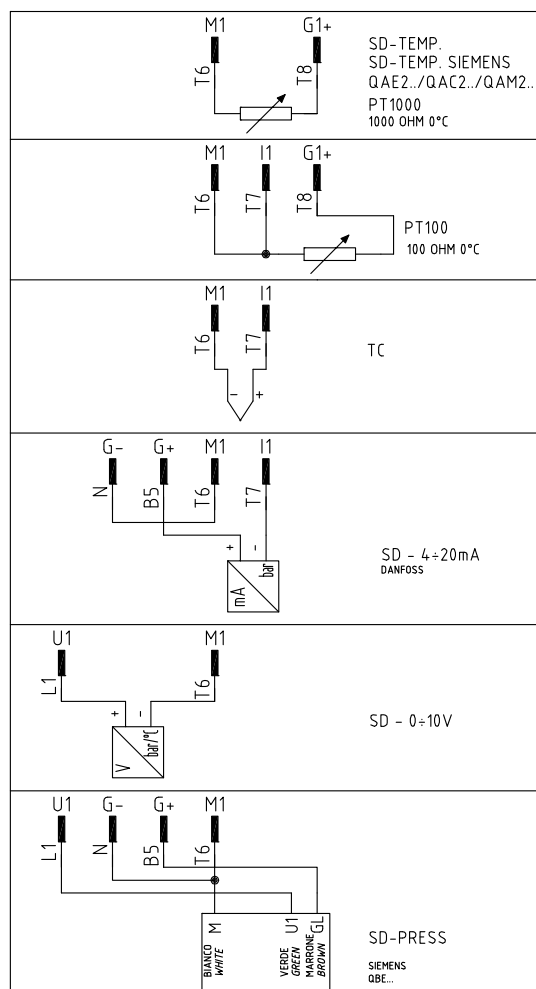

Fig. 37 - Probes connection

- LB BURNER LOCKOUT SIGNALLING LAMP
- LBF BURNER IN LOW FLAME SIGNALLING LAMP
- MV FAN MOTOR
- SD-0+10V VOLTAGE SIGNAL
- SD-0/4+20mA CURENT SIGNAL
- SD-PRESS PRESSURE PROBE
- SMA MAN/AUTO SELECTOR
- SMF OPERATION SELECTOR MIN-0-MAX
- ST PRESSURE SWITCHES OR THERMOSTATS SERIE
- TS SAFETY THERMOSTAT/PRESSURE SWITCH

Power supply without neutral

If the power supply to the burner is 230V phase-phase (without the neutral wire), with the Siemens LGB2..., LMG2... or LME.. flame control device, between the terminal 2 on the board and the earth terminal, an RC Siemens RC466890660 filter must be inserted.

Key

C - Capacitor (22nF/250V)

R - Resistor (1Mohm)

(***) RC466890660 - RC Siemens filter

(Code: 2531003)

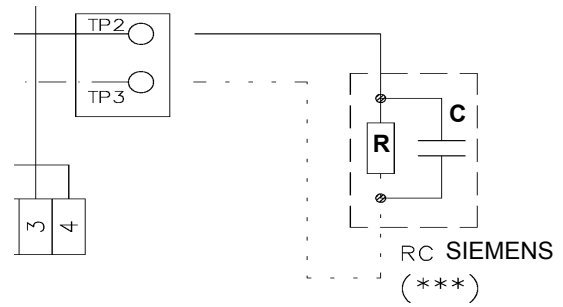
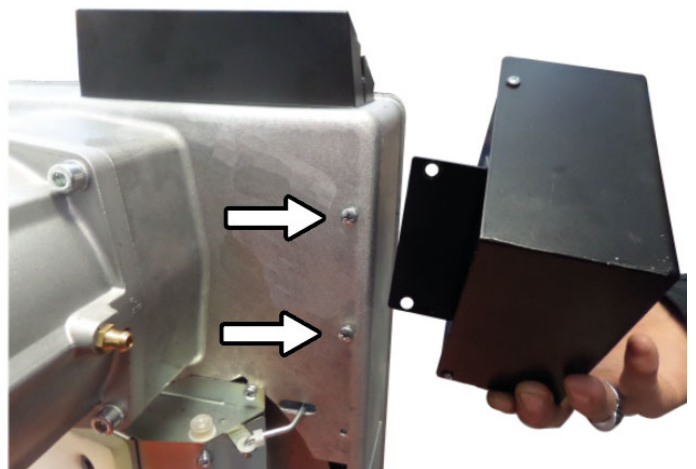
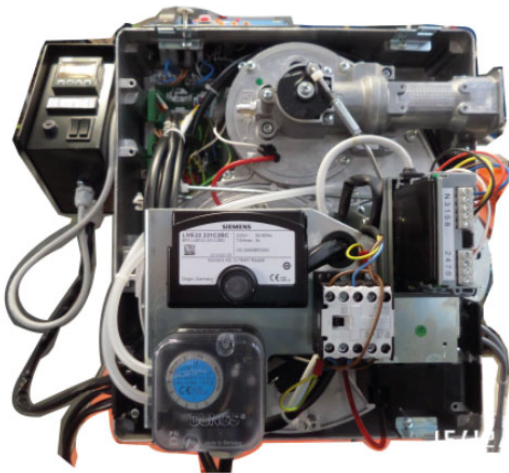

Fig. 38

Mounting the control stand



Mount as shown in the figure

PART III: OPERATION**LIMITATIONS OF USE**

THE BURNER IS AN APPLIANCE DESIGNED AND CONSTRUCTED TO OPERATE ONLY AFTER BEING CORRECTLY CONNECTED TO A HEAT GENERATOR (E.G. BOILER, HOT AIR GENERATOR, FURNACE, ETC.), ANY OTHER USE IS TO BE CONSIDERED IMPROPER AND THEREFORE DANGEROUS.

THE USER MUST GUARANTEE THE CORRECT FITTING OF THE APPLIANCE, ENTRUSTING THE INSTALLATION OF IT TO QUALIFIED PERSONNEL AND HAVING THE FIRST COMMISSIONING OF IT CARRIED OUT BY A SERVICE CENTRE AUTHORIZED BY THE COMPANY MANUFACTURING THE BURNER.

A FUNDAMENTAL FACTOR IN THIS RESPECT IS THE ELECTRICAL CONNECTION TO THE GENERATOR'S CONTROL AND SAFETY UNITS (CONTROL THERMOSTAT, SAFETY, ETC.) WHICH GUARANTEES CORRECT AND SAFE FUNCTIONING OF THE BURNER.

THEREFORE, ANY OPERATION OF THE APPLIANCE MUST BE PREVENTED WHICH DEPARTS FROM THE INSTALLATION OPERATIONS OR WHICH HAPPENS AFTER TOTAL OR PARTIAL TAMPERING WITH THESE (E.G. DISCONNECTION, EVEN PARTIAL, OF THE ELECTRICAL LEADS, OPENING THE GENERATOR DOOR, DISMANTLING OF PART OF THE BURNER).

NEVER OPEN OR DISMANTLE ANY COMPONENT OF THE MACHINE.

OPERATE ONLY THE MAIN SWITCH, WHICH THROUGH ITS EASY ACCESSIBILITY AND RAPIDITY OF OPERATION ALSO FUNCTIONS AS AN EMERGENCY SWITCH, AND ON THE RESET BUTTON.

IN CASE OF A BURNER SHUT-DOWN, RESET THE CONTROL BOX BY MEANS OF THE RESET PUSHBUTTON. IF A SECOND SHUT-DOWN TAKES PLACE, CALL THE TECHNICAL SERVICE, WITHOUT TRYING TO RESET FURTHER.

WARNING: DURING NORMAL OPERATION THE PARTS OF THE BURNER NEAREST TO THE GENERATOR (COUPLING FLANGE) CAN BECOME VERY HOT, AVOID TOUCHING THEM SO AS NOT TO GET BURNT.

OPERATION

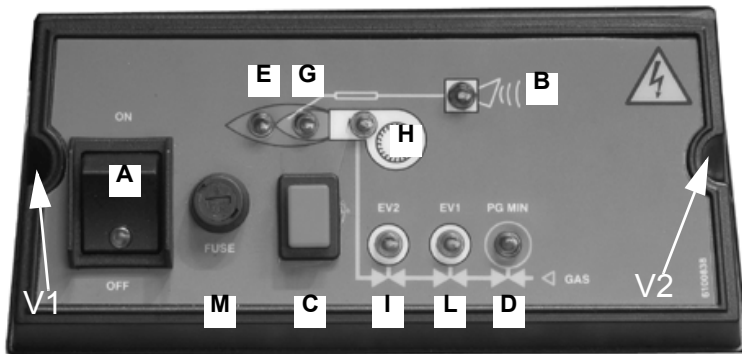

Fig. 39 - Burner's control panel

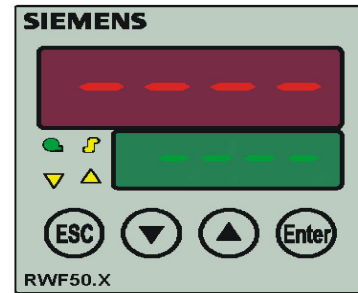

Fig. 40 - RFW50 Burner modulator

Key -

- A Mains switch ON - OFF
- B Lockout signaling lamp
- C Reset button for flame control device (optional)
- D Minimum gas pressure switch consent signaling lamp
- E High flame operation signaling lamp (or air damper opening during pre-purge stage)
- G Low flame operation signaling lamp
- H Ignition transformer in operation signaling light
- I EV2 opening signaling lamp
- L EV1 opening signaling lamp
- M Fuse

- Set to ON position the mains switch A on the burner electrical board front panel.
- Check the flame control device is not in the lockout position (light B on), if necessary reset it by means of the pushbutton C (reset), pushing for more than 0.5 seconds but less than 3 seconds;
- Verify that the control thermostats or pressure switches give the consent to operate to the burner.
- Check the gas supply pressure is sufficient (light D on).

Only burners provided with gas proving system: the check cycle of the leakage control device starts; the completion of this check is signalled by the light of the lamp on the device. When the valves check is finished, the start up cycle of the burner begins. In the case of a leak in a valve, the leakage control device locks and its red lamp lights.

To reset the device operate on the device pushbutton.

All burners

- When the startup cycle begins, the servocontrol drives the air damper to the maximum opening position, the fan motor starts and the pre-purge phase begins.

During the pre-purge phase, the complete opening of the air damper is signalled by the light E on the frontal panel of the electrical board.

- At the end of the pre-purge phase, the air damper goes to the ignition position, the ignition transformer comes on (signalled by the light H) and 3 seconds later the solenoid valves EV1 and EV2 are energized (lights L and I on the front panel).
- Few seconds after the opening of the valves, the ignition transformer comes off and the lamp H turns off; subsequently:

Single stage burners: the burner is on at the maximum power; the lights E and G are on;

High-low flame burners: the burner is on in low flame (light G is on); 8 seconds later the high flame operation begins and the burner switches automatically to high flame (light E is on) or remains in low flame operation, depending on the plant needs.

Modulating burners: they are provided with the Siemens RWF40 modulator, placed on the burner side. As for the modulator operation see the related manual.

GAS AND AIR FLOW RATE SETTINGS

	<p>ATTENTION: before starting the burner up, be sure that the manual cutoff valves are open and check that the pressure upstream the gas train complies the value quoted on paragraph "Technical specifications". Be sure that the mains switch is closed.</p>
	<p>ATTENTION: During commissioning operations, do not let the burner operate with insufficient air flow (danger of formation of carbon monoxide); if this should happen, make the fuel decrease slowly until the normal combustion values are achieved.</p>
	<p>WARNING: NEVER LOOSE THE SEALED SCREWS! OTHERWISE, THE DEVICE WARRANTY WILL BE INVALIDATE!</p>

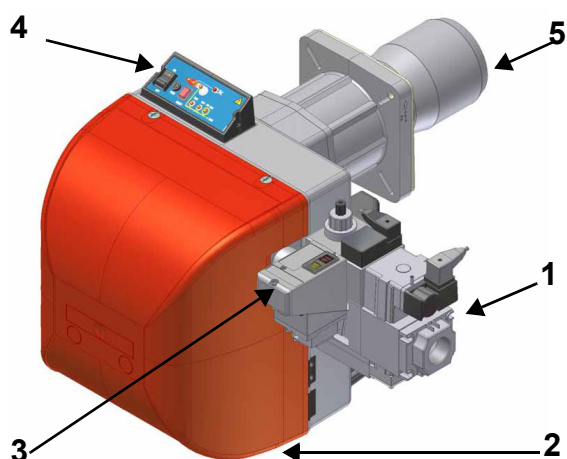

Fig. 41

Keys

- 1 Valve group
- 2 Cover
- 3 Gas proving system
- 4 Control panel
- 5 Blast tube

To perform the adjustments, unscrew the fixing screws and remove the burner's cover (see Fig. 41-2)

Startup Output

The start-up heat output shall not exceed 120 kW (single stage burners) or 1/3 of nominal output (double-stage, progressive or fully modulating burners). In order to comply with these requirements, burners are provided with butterfly valve and/or slow-opening safety valve. On double-stage, progressive or modulating burners, the low flame output must be higher than the minimum output quoted in the performance curve (page 12).



IMPORTANT! the combustion air excess must be adjusted according to the in the following chart:

Recommended combustion parameters		
Fuel	Recommended (%) CO ₂	Recommended (%) O ₂
Natural gas	9 ÷ 10	4.8 ÷ 3
LPG	11 ÷ 12	4.3 ÷ 2.8

Actuator

As for the setting, refer to this correspondence table.

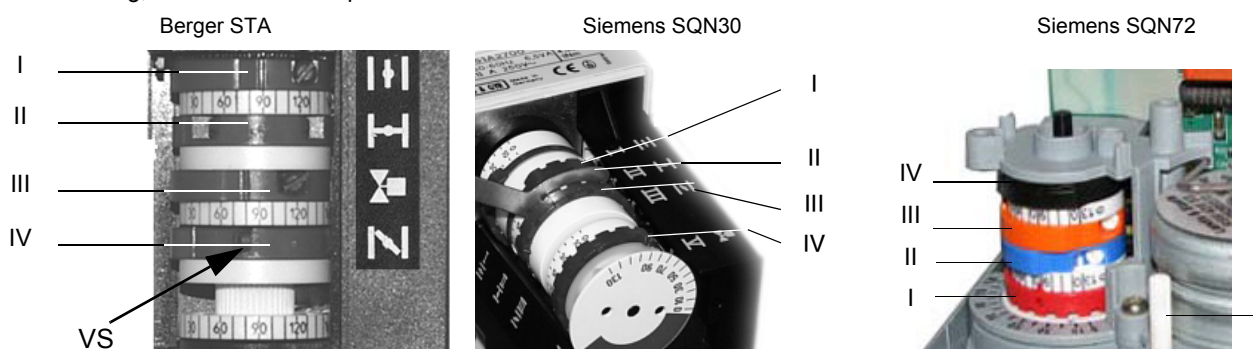

	BERGER STA	Siemens SQN30	Siemens SQN72
High flame position (set to 90°)	I	I	I (red)
Low flame and ignition position	IV	III	III (orange)
Stand-by position (set to 0°)	II	II	II (blue)
Not used	III	V	IV (black)

- .Berger STA12: On this actuator, the manual control of the air damper is not provided; the setting of the cams is carried out working with a screwdriver on the **VS** screw placed internally to the cam..
- Siemens SQN72: a key is provided to move cams I and IV, the other cams can be moved by means of screws. On the Siemens actuator the AUTO/MAN mode is provided (see picture).

AUTO/MAN

Adjusting the gas valves group

Multibloc MB-DLE

The multibloc unit is a compact unit consisting of two valves, gas pressure switch, pressure stabilizer and gas filter.

The valve is adjusted by means of the **RP** regulator after slackening the locking screw **VB** by a number of turns. By unscrewing the regulator **RP** the valve opens, screwing the valve closes. To set the fast opening remove cover **T**, reverse it upside down and use it as a tool to rotate screw **VR**. Clockwise rotation reduces start flow rate, anticlockwise rotation increases it.

Do not use a screwdriver on the screw **VR**!

The pressure stabilizer is adjusted by operating the screw **VS** located under the cover **C**. By screwing down the pressure is increased and by unscrewing it is reduced.

Note: the screw **VSB** must be removed only in case of replacement of the coil.

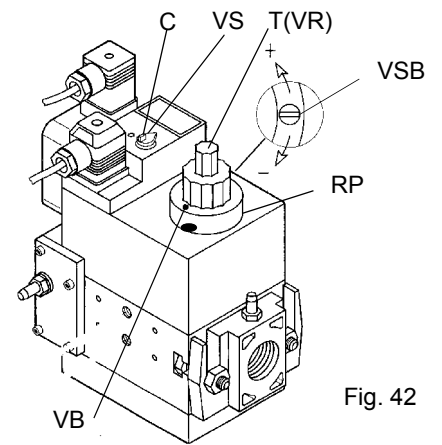

Fig. 42

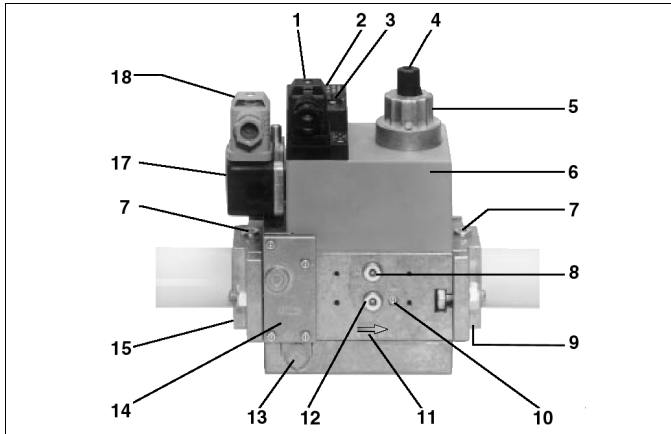

Fig. 43

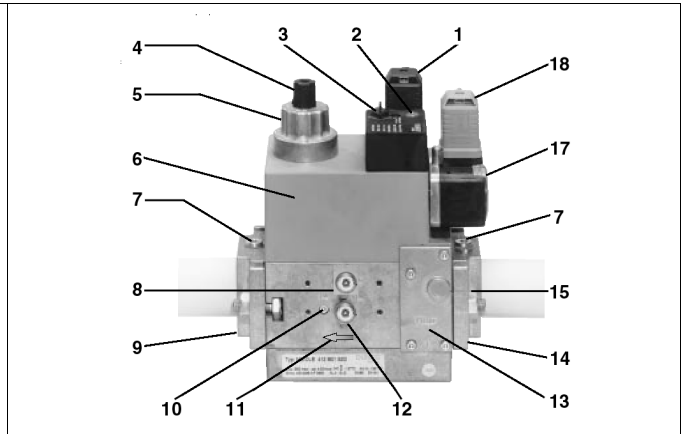

Fig. 44

Key

- | | |
|--|---|
| 1 Electrical connection for valves | 9 Output flange |
| 2 Operation display (optional) | 10 Test point connection M4 downstream of valve 2 |
| 3 Pressure governor closing tap | 11 Gas flow direction |
| 4 Start setting cap | 12 Test connection G 1/8 downstream of valve 1, on both sides |
| 5 Hydraulic brake and rate regulator | 13 Vent nozzle pressure regulator |
| 6 Coil | 14 Filter (below cover) |
| 7 Test point connection G 1/8 | 15 Input flange |
| 8 Test point connection G 1/8 downstream of valve 1, on both sides | 17 Pressure switch |
| | 18 Pressure switch electric connection |

Combustion head

The burner is adjusted in the factory with the combustion head in the position that refers to the "MAX" output. The maximum output setting refers to the "fully-ahead" position of the combustion head, as far as standard models (Fig. 48), and to "fully-backward" position for low NOx burners (Fig. 47). As for "fully-ahead" position, it means that the head is placed inside the boiler, "fully-backward" position means that the head is towards the operator. As far as the reduced output operation, progressively move the combustion head towards the "MIN" position, rotating clockwise the **VRT** screw (Fig. 45). The **ID** index shows how much the combustion head moved.

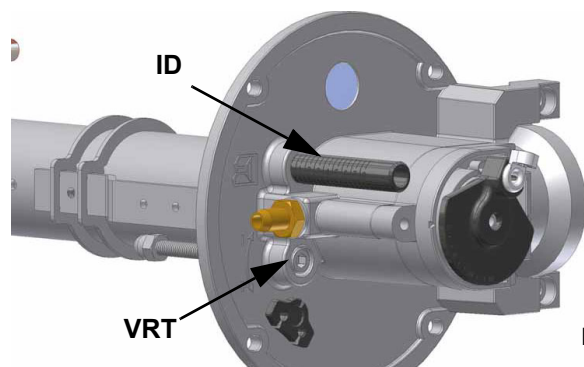

Fig. 45

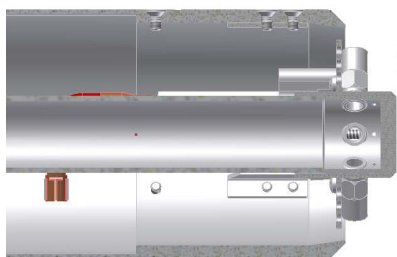

Fig. 46 - Head in "fully-ahead position"

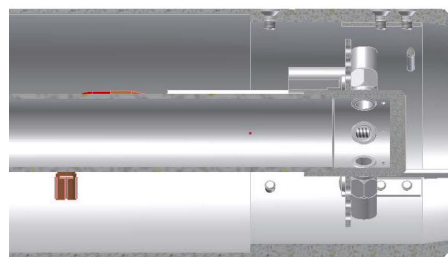

Fig. 47 - Head in "fully-backward position"

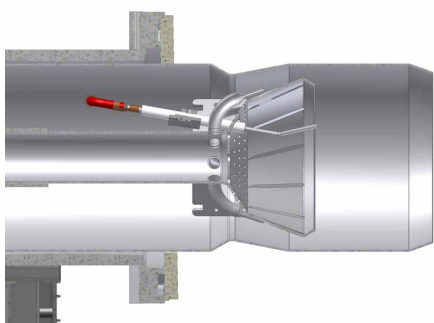

Fig. 48 - Head in "fully-ahead position"

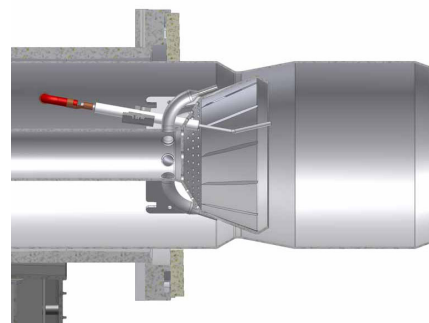

Fig. 49 - Head in "fully-backward position"

Adjustment procedure

To change the burner setting during the testing in the plant, follows the next procedure, according to the burner operation.

⚠ go on adjusting air and gas flow rates: check, continuously, the flue gas analysis, as to avoid combustion with little air; dose the air according to the gas flow rate change following the steps quoted below;

⚠ Pressure governor is factory-set. The setting values must be locally adapted to machine conditions. Important! Follow the instructions of the burner manufacturer!

● Adjustments for single-stage burners

- 1 remove the burner cover
- 2 startup the burner by turning its main switch **A** to on: if the burner locks (LED **B** on in the control panel) press the RESET button (**C**) on the control panel (Fig. 36).
- 3 loosen **VR** screw (see picture). Move the **ID** index towards + or -, in order to increase or decrease the air flow-rate, according to the required combustion values; Fasten the **VR** screw again.
- 4 Acting on the pressure stabilizer of the valves group (see "Adjusting the gas valves group" on page 38) adjust the gas flow rate

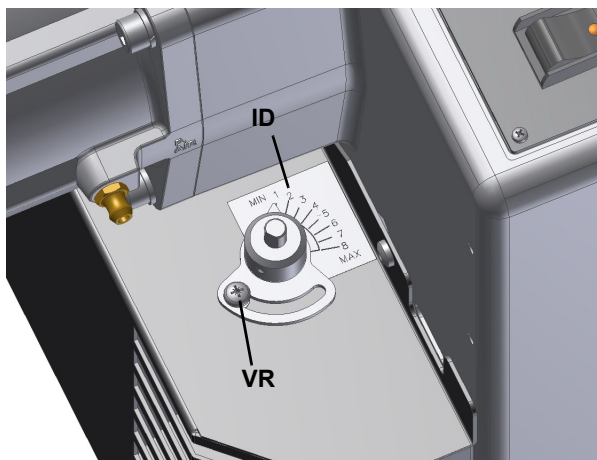

LG/NG/NGX280 - TN

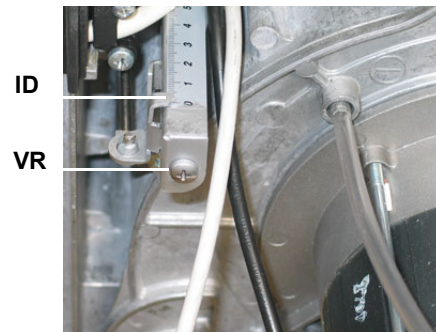

LG/NG/NGX350-400 TN

● Adjustments for double-stage burners mod. LG/NG/NGX280

- 1 remove the burner cover
- 2 Before starting the burner up, drive the high flame actuator microswitch matching the low flame one (in order to let the burner operates at the lowest output) to safely achieve the high flame stage
- 3 startup the burner by turning its main switch **A** to on: if the burner locks (LED **B** on in the control panel) press the RESET button (**C**) on the control panel (Fig. 36).
- 4 Move the high flame cam of the servocontrol to open the servocontrol by a few degrees. The servocontrol opens the gas throttle valve by means of the L linkage and at the same time it opens the air damper by means of the cam shown in Fig. 49
- 5 If necessary, after checking that the combustion complies with the recommended parameters in the table in the "Ignition power" section. Adjust the position of the air damper by acting on the slotted cam. "Startup Output". (Fig. 49)
- 6 Proceed in this way until the maximum opening of the servocontrol is reached.
- 7 Acting on the pressure stabilizer of the valves group (see "Adjusting the gas valves group" on page 38) adjust the gas flow rate
- 8 Adjust the position of the combustion head if necessary (see section "Combustion Head").
- 9 Once the combustion point has been adjusted to a high flame, turn the burner to a low flame using the high/low thermostat. TAB of the boiler, checking the combustion point by point.
- 10 To eventually change the gas flow rate, set at step 6, slacken the screw **V1** (see picture) and set the opening angle of the butterfly valve rotating the round plate **C** by means of the screw **V3** (turn clockwise to decrease the gas rate or counterclockwise to increase it). The index **S** shows the opening angle of the butterfly valve.
- 11 Check combustion and burner gas flow in high flame again.

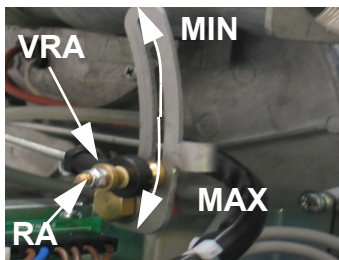

Fig. 49

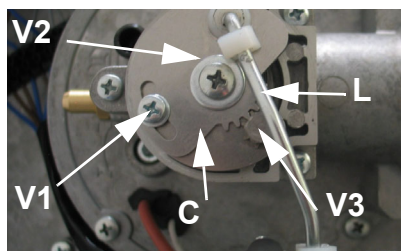

Fig. 50

Note: If it should be necessary to adjust the rating of the burner in low flame operation, once all the adjustments are accomplished, act on the related cam of the actuator. Then, check the gas rate and, eventually, repeat previous steps.

● **Progressive or fully-modulating burners**

- 1 Before starting the burner up, drive the high flame actuator microswitch matching the low flame one (in order to let the burner operates at the lowest output) to safely achieve the high flame stage.
- 2 startup the burner by turning its main switch **A** to on: if the burner locks (LED **B** on in the control panel) press the RESET button (**C**) on the control panel (Fig. 36).
- 3 drive the burner to high flame stage, by means of the thermostat **TAB** (high/low flame thermostat - see Wiring diagrams), as far as fully-modulating burners, see related paragraph.
- 4 Then move progressively the microswitch to higher values until it reaches the high flame position; always check the combustion values and eventually adjusting the gas by means of the valves group stabiliser.

To adjust the air flow rate, follow this procedure: find the **V** screw on the adjusting cam **SV** (see next picture), matching with the bearings that move along the foil and related to the servocontrol position. unscrew the **V** screw to increase the air flow rate, unscrew to decrease it

To adjust the gas flow rate, act on the pressure stabilizer of the valves group (see “Adjusting the gas valves group” on page 38)

- 5 Once the high flame position is reached, open the gas valve completely. To reach the required flow rate act on the stabilizer
- 6 Adjust, if necessary, the position of the combustion head(see paragraph)
- 7 Check combustion parameters and, if necessary, adjust the air flow rate or gas pressure as described above.
- 8 once the maximum flow rate is fixed, shortcircuit for a while, the thermostat **TAB** T6 and T7 terminals (see pag. 45). As far as the fully-modulating models, see next paragraph. The actuator will move towards the low flame position; then remove the bridge;
- 9 then adjust the screw **V** related to that position;
- 10 repeat all these instructions for all the actuator stroke, in order to define the foil shape.

Note: If it should be necessary to adjust the rating of the burner in low flame, work on the corresponding cam of the actuator. After this operation, check the gas rate and verify the combustion values. In case of lack or excess of air, work on the screws **V** of the adjusting cam matching the setting point of the air rate in low flame; unscrew to increase the air rate or screw to decrease it.

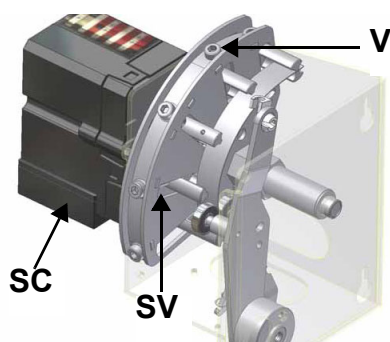

DOUBLE-STAGE-PROGRESSIVE-FULLY-MODULATING

Fully modulating burners

To adjust the fully-modulating burners, use the **CMF** switch on the burner control panel (see next picture), instead of the **TAB** thermostat as described on the previous paragraphs about the progressive burners. Go on adjusting the burner as described before, paying attention to use the CMF switch instead of **TAB**.

The **CMF** position sets the operating stages: to drive the burner to the high-flame stage, set CMF=1; to drive it to the low-flame stage, set CMF=2.

To move the adjusting cam set CMF=1 or 2 and then CMF=0.

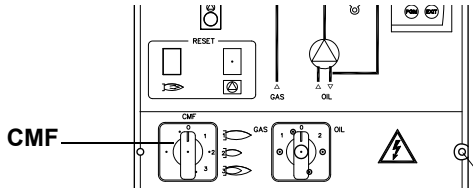

- CMF = 0 stop at the current position
- CMF = 1 high flame operation
- CMF = 2 low flame operation
- CMF = 3 automatic operation

Gas Proving System VPS504 (Option)

The VPS504 checks the operation of the seal of the gas shut off valves. This check, carried out as soon as the boiler thermostat gives a start signal to the burner, creates, by means of the diaphragm pump inside it, a pressure in the test space of 20 mbar higher than the supply pressure.

To install the DUNGS VPS504 gas proving system on the MD-DLE valves group, proceed as follows:

- 1 turn off gas supply.;
- 2 Switch off power supply.
- 3 remove the Multibloc's screw plugs (Fig. 52-A);
- 4 insert sealing rings (10,5 x 2,25) into VPS 504 (Fig. 53-B, Fig. 52-B)
- 5 Torque screws 3, 4, 5, 6 (M4 x16) Fig. 52-C

Only use screws with metric thread on reassembly (modification, repair).

- 6 On completion of work, perform a leak and functional test.

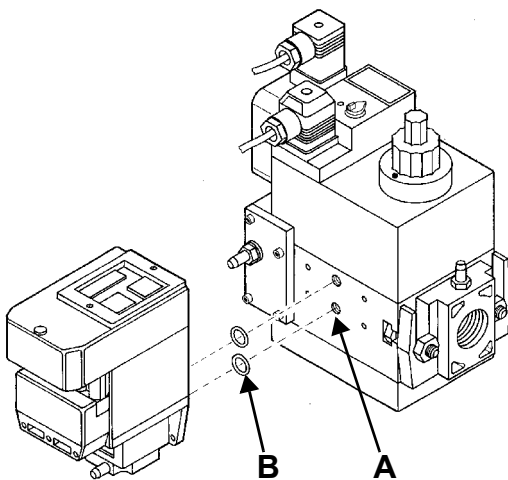

Fig. 52

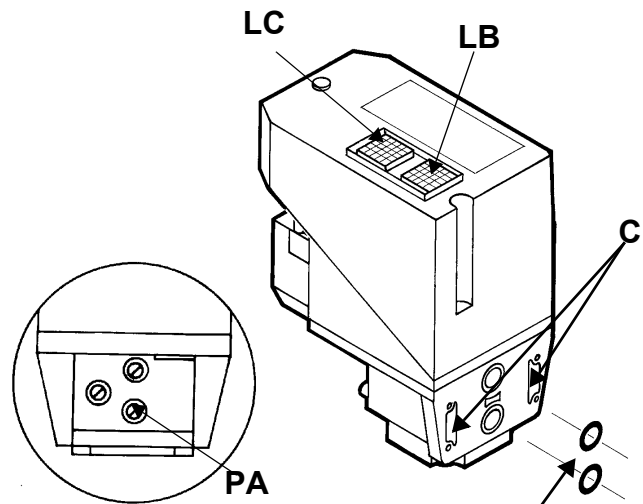

Fig. 53

When wishing to monitor the test, install a pressure gauge ranged to that of the pressure supply point **PA** (Fig. 53). If the test cycle is satisfactory, after a few seconds the consent light **LC** (yellow) comes on. In the opposite case the lockout light **LB** (red) comes on. To restart it is necessary to reset the appliance by pressing the illuminated pushbutton **LB**.

Calibration of air and gas pressure switches

The **air pressure switch** locks the control box if the air pressure is not the one requested. If it happens, unlock the burner by means of the control box unlock pushbutton, placed on the burner control panel.

The **gas pressure switches** check the pressure to avoid the burner operate when the pressure value is not in the requested pressure range.

Calibration of air pressure switch (only for single stage burners)

Calibration is carried out as follows:

- Remove the transparent plastic cap.
- Once air and gas setting have been accomplished, startup the burner.

- While the burner is operating, rotate slowly and clockwise the adjusting ring nut **VR**, until the burner locks; read the pressure value on the scale of the pressure switch and set it again to a value reduced by the 15%.
- Repeat the start-up cycle and check the burner runs properly.
- Refit the transparent plastic cover on the pressure switch.

Calibration of air pressure switch (double-stage, progressive and fully-modulating)

To calibrate the air pressure switch, proceed as follows:

- Remove the transparent plastic cap.
- Once air and gas setting have been accomplished, startup the burner.
- During the pre-purge phase of the operation, turn slowly the adjusting ring nut **VR** in the clockwise direction until the burner lockout, then read the value on the pressure switch scale and set it to a value reduced by 15%.
- Repeat the ignition cycle of the burner and check it runs properly.
- Refit the transparent plastic cover on the pressure switch.

Calibration of low gas pressure switch

As for the gas pressure switch calibration, proceed as follows:

- Be sure that the filter is clean.
- Remove the transparent plastic cap.
- While the burner is operating at the maximum output, test the gas pressure on the pressure port of the minimum gas pressure switch.
- Slowly close the manual cutoff valve (placed upstream the pressure switch, see gas train installation diagram), until the detected pressure is reduced by 50%. Pay attention that the CO value in the flue gas does not increase: if the CO values are higher than the limits laid down by law, slowly open the cutoff valve as to get values lower than these limits.
- Check that the burner is operating correctly.
- Clockwise turn the pressure switch adjusting ring nut (as to increase the pressure value) until the burner stops.
- Slowly fully open the manual cutoff valve.
- Refit the transparent plastic cover on the pressure switch.



Fig. 54

Adjusting the maximum gas pressure switch (when provided)

To calibrate the maximum pressure switch, proceed as follows according to its mounting position:

- 1 remove the pressure switch plastic cover;
- 2 if the maximum pressure switch is mounted upstream the gas valves: measure the gas pressure in the network, when flame is off; by means of the adjusting ring nut **VR**, set the value read, increased by the 30%.
- 3 if the maximum pressure switch is mounted downstream the "gas governor-gas valves" group and upstream the butterfly valve: light the burner, adjust it according to the procedure in the previous paragraph. Then, measure the gas pressure at the operating flow rate, downstream the "gas governor-gas valves" group and upstream the butterfly valve; by means of the adjusting ring nut **VR**, set the value read on step 2, increased by the 30%;
- 4 replace the plastic cover.

PART IV: MAINTENANCE

At least once a year carry out the maintenance operations listed below. In the case of seasonal servicing, it is recommended to carry out the maintenance at the end of each heating season; in the case of continuous operation the maintenance is carried out every 6 months.



WARNING: ALL OPERATIONS ON THE BURNER MUST BE CARRIED OUT WITH THE MAINS DISCONNECTED AND THE FUEL MANUAL CUTOFF VALVES CLOSED!

ATTENTION: READ CAREFULLY THE "WARNINGS" CHAPTER AT THE BEGINNING OF THIS MANUAL.

ROUTINE MAINTENANCE

- Clean and examining the gas filter cartridge, if necessary replace it (Fig. 55 on).
- Removal, examination and cleaning of the combustion head.
- Check the ignition and detection electrodes, clean and adjust if necessary (see Fig. 66). In case of doubt, check the detection current according to the schemes in Fig. 65.
- Cleaning and greasing of sliding and rotating parts.



ATTENTION when servicing, if it was necessary to disassemble the gas train parts, remember to execute the gas proving test, once the gas train is reassembled, according to the procedure imposed by the law in force.

Removing the filter in the MULTIBLOC DUNGS MB-DLE 405..412

- Check the filter at least once a year!
- Change the filter if the pressure difference between pressure connection 1 and 3 (Fig. 55-Fig. 56) is $\Delta p > 10$ mbar.
- Change the filter if the pressure difference between pressure connection 1 and 3 (Fig. 55-Fig. 56) is twice as high compared to the last check.

You can change the filter without removing the fitting.

- 1 Interrupt the gas supply closing the on-off valve.
- 2 Remove screws 1 ÷ 4 using the Allen key n. 3 and remove filter cover 5 in Fig. 57.
- 3 Remove the filter 6 and replace with a new one.
- 4 Replace filter cover 5 and tighten screws 1 ÷ 4 without using any force and fasten.
- 5 Perform leakage and functional test, $p_{max.} = 360$ mbar.
- 6 Pay attention that dirt does not fall inside the valve.

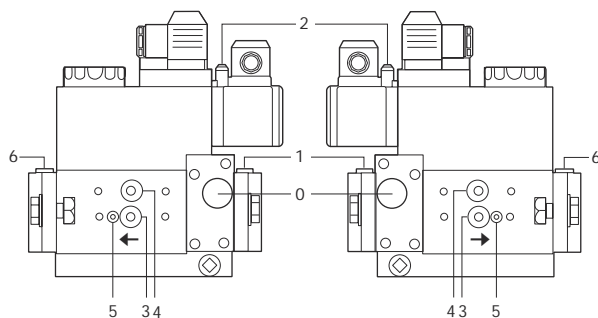

Fig. 55

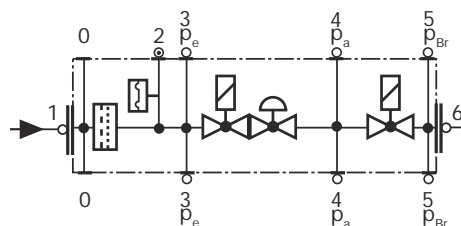

Fig. 56

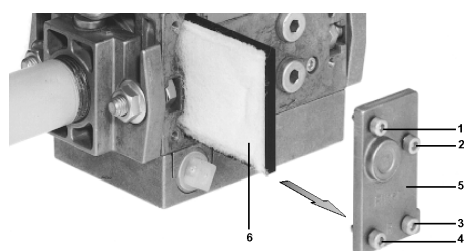

Fig. 57

Removing the filter in the MULTIBLOC DUNGS MB-DLE 415 - 420 B01 1" 1/2 - 2"

- Check the filter at least once a year!
- Change the filter if the pressure difference between pressure connection 1 and 2 (Fig. 58-Fig. 59) $\Delta p > 10$ mbar.
- Change the filter if the pressure difference between pressure connection 1 and 2 (Fig. 58-Fig. 59) is twice as high compared to the last check.

You can change the filter without removing the fitting.

- 1 Interrupt the gas supply closing the on-off valve.
- 2 Remove screws 1 ÷ 6 (Fig. 60).
- 3 Change filter insert.
- 4 Re-insert filter housing, screw in screws 1 ÷ 6 without using any force and fasten.
- 5 Perform leakage and functional test, $p_{max.} = 360$ mbar.
- 6 Pay attention that dirt does not fall inside the valve.

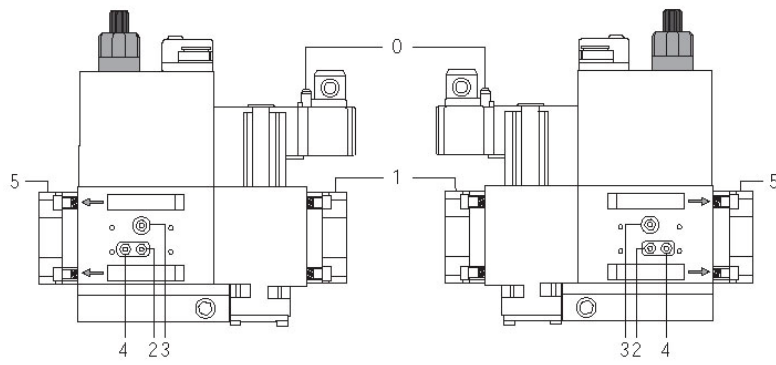

Fig. 58

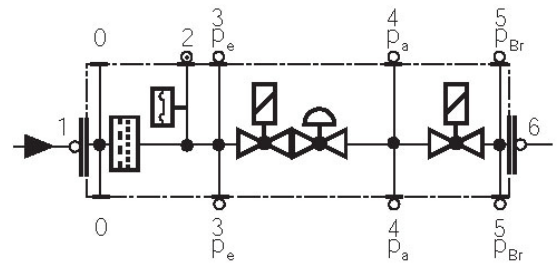

Fig. 59

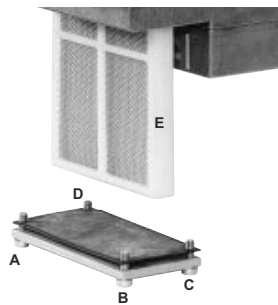

Fig. 60

Removing and cleaning the combustion head

- 1 By means of the plastic hook **G**, unlock the rod **T** (Fig. 61) which drives the butterfly valve (Fig. 61 and Fig. 62), to disconnect it from its seat.
- 2 Remove the screws **V1**, **V2**, **V3**, **V4** and the screws **S1** and **S2** (Fig. 61).
- 3 Disconnect the ignition cable **CA** from the ignition transformer (Fig. 63).
- 4 Disconnect the connector **CR** (Fig. 64).

CAUTION: during the assembling phase, before tightening screws **V1**, **V2**, **V3**, **V4**, mount and tighten screws **S1** and **S2**. To remove the head, the operator must pull it towards himself. Once the combustion head is removed, check that the air and gas holes are not obstructed (Fig. 64 - **H**). Clean the combustion head by a compressed air blow or, in case of scale, scrape it off by a scratchbrush.

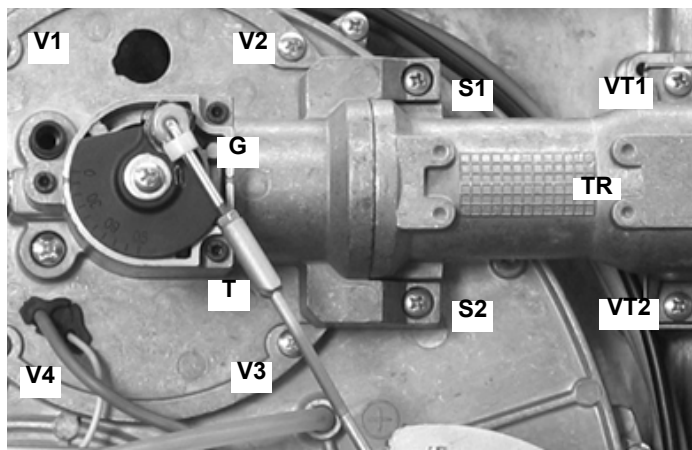

Fig. 61

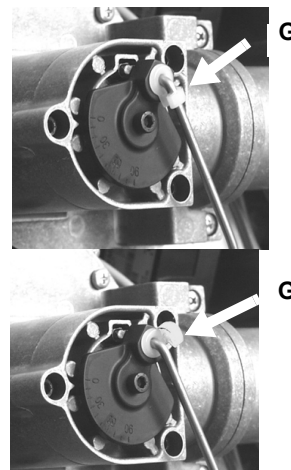

Fig. 62

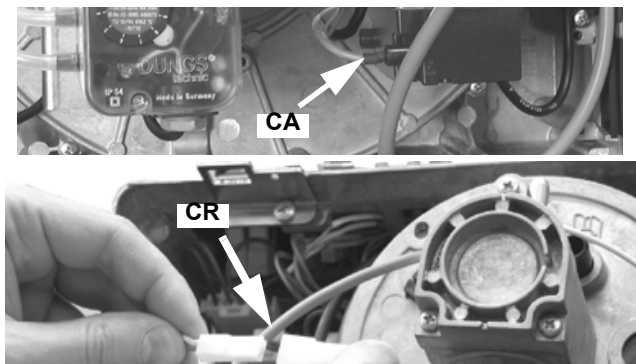

Fig. 63



Fig. 64

Checking the detection current

If the burner locks, execute the following inspections. To measure the detection signals refer to the diagrams in Fig. 65. If the signal is less than the value shown, check the position of the detection electrode, the electrical contacts and if necessary replace the detection electrode.

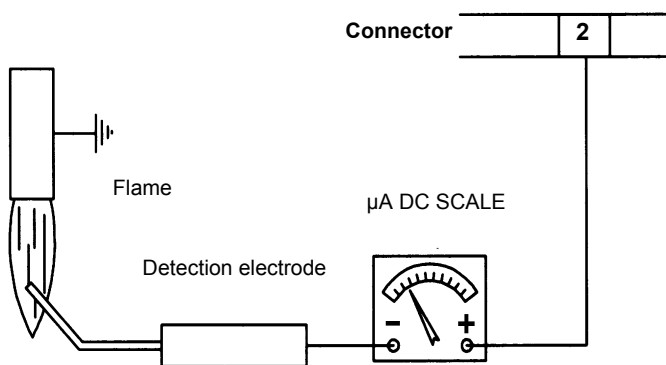
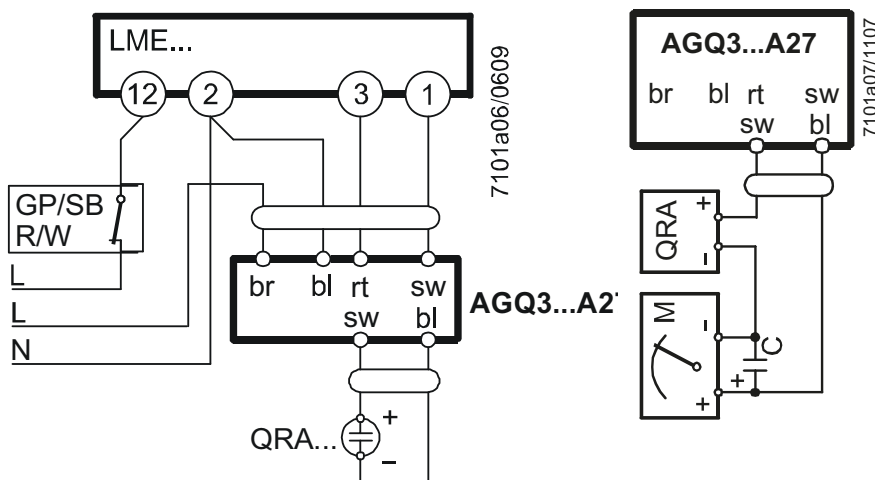

Fig. 65

Control box	Minimum detection signal
Siemens LME21-22	3 µA

Flame supervision with QRA2 + ACQ3.1A27.. (just for LME2x ...)

Device	Flame detector	Measure at the detector UV QRA...
Siemens LME2x	QRA2	200 µA



Adjusting the electrodes position

ATTENTION: avoid the ignition and detection electrodes to get in touch with metallic parts (blast tube, head, etc.), otherwise the boiler's operation would be compromised. Check the electrodes position after any intervention on the combustion head.

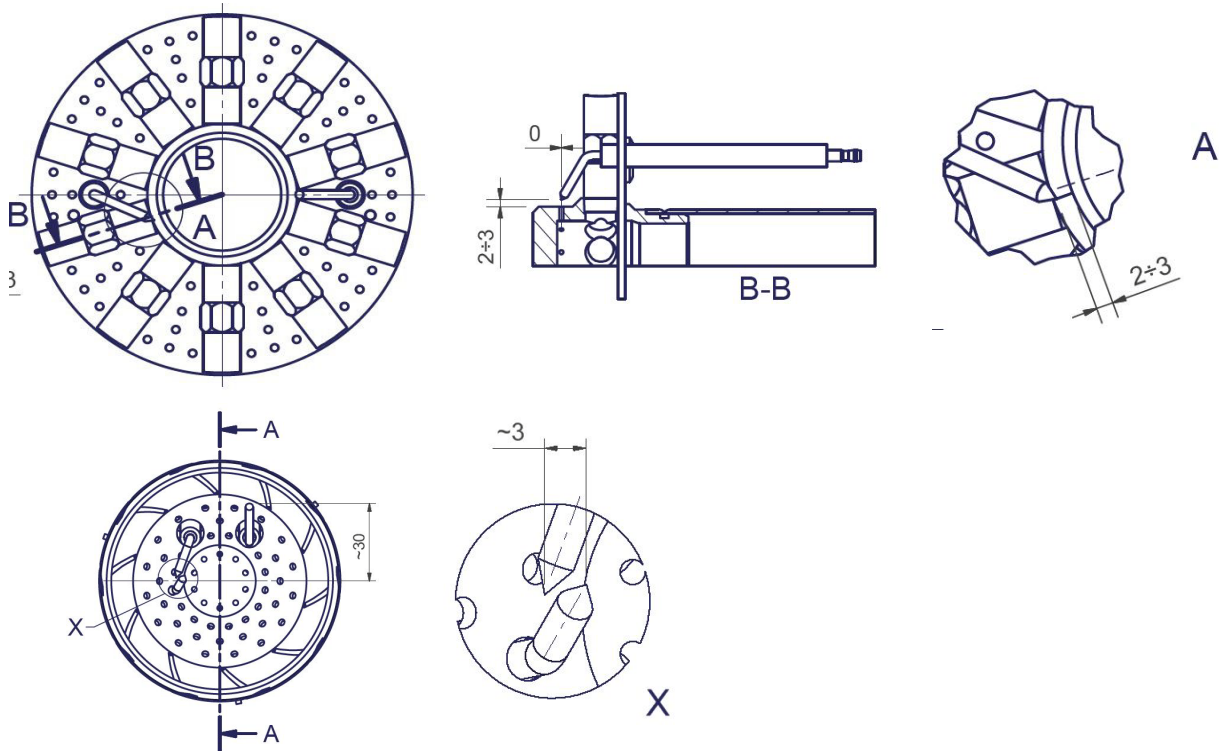

Seasonal stop

To stop the burner in the seasonal stop, proceed as follows:

- 1 turn the burner main switch to 0 (Off position)
- 2 disconnect the power mains
- 3 close the fuel valve of the supply line

Burner disposal

In case of disposal, follow the instructions according to the laws in force in your country about the "Disposal of materials".

WIRING DIAGRAMS

Wiring diagrams (see attached document)

LG/NG/NGX 280 Single stage - Electric wiring diagrams - SE01-530

LG/NG/NGX 280 Double stage - Progressive - Electric wiring diagrams - SE18-103

LG/NG/NGX 350-400 Electric wiring diagrams - SE18-163, SE18-057

TROUBLESHOOTING

CAUSE	TROUBLE											
	THE BURNER DOESN'T START	CONTINUE WITH PRE-PURGE	DOESN'T START AND LOCK-OUT	DOESN'T START AND REPEATS THE CYCLE	STARTS AND REPEATS THE CYCLE	STARTS AND LOCK-OUT	THE FLAME MONITOR DEVICE DOESN'T GIVE CONSENT TO START	DOESN'T SWITCH TO HIGH FLAME	DOESN'T RETURN IN LOW FLAME	THE SERVO CONTROL IS LOCK AND VIBRATE	LOCK-OUT DURING OPERATION	TURNS OF AND REPEATS CYCLE DURING OPERATION
MAIN SWITCH OPEN	●											
LACK OF GAS	●			●								
MAXIMUM GAS PRESSURE SWITCH DEFECTIVE (IF PROVIDED)	●		●									
THERMOSTATS/PRESSURE SWITCHES DEFECTIVE	●			●								●
OVERLOAD TRIPPED INTERVENTION	●											
AUXILIARIES FUSE INTERRUPTED	●											
CONTROL BOX FAULTY	●	●	●			●					●	
DEFECTIVE SERVOCONTROL (IF PROVIDED)	●	●	●				♦					
AIR PRESSURE SWITCH FAULT OR BAD SETTING	●					●	●				●	
MINIMUM GAS PRESSURE SWITCH DEFECTIVE OR GAS FILTER DIRTY	●			●	●		●					●
IGNITION TRANSFORMER FAULT			●									
IGNITION ELECTRODES BAD POSITION			●									
DETECTION ELECTRODE BAD POSITION						●					●	
BUTTERFLY VALVE BAD SETTING			●			●						
DEFECTIVE GAS GOVERNOR			●	●	●							●
GAS VALVE DEFECTIVE			●									
BAD CONNECTION OR DEFECTIVE HIGH/LOW FLAME THERMOSTAT OR PRESSURE SWITCH (IF PROVIDED)							♦	●	●	♦		
WRONG SETTING SERVO CONTROL CAM							l	l	l			
UV PROBE DIRTY OR DEFECTIVE (IF PROVIDED)			l			l					l	
PHASE-NEUTRAL INVERTED						s						
PHASE-PHASE SUPPLY OR PRESENCE OF VOLTAGE ON THE NEUTRAL CONDUCTOR(*)						s						

l = with any control box;

s = with only LGB2../LMG2../LME11/LME2..

(*) In such cases, insert the circuit SIEMENS "RC466890660" () See chapter "Electrical connections"

VERSIONE MONOSTADIO "TN" "TN" SINGLE-STAGE VERSION

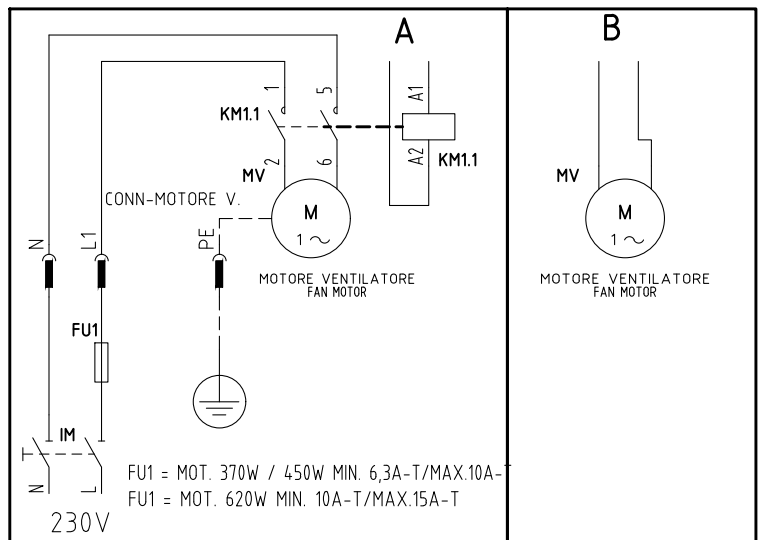
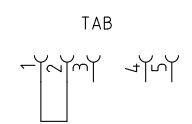
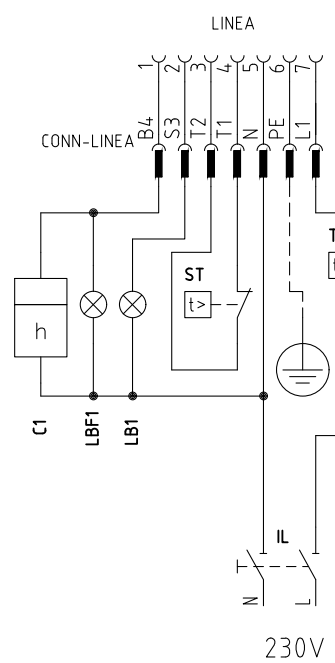
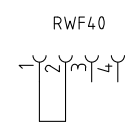
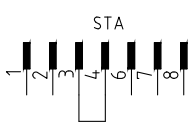
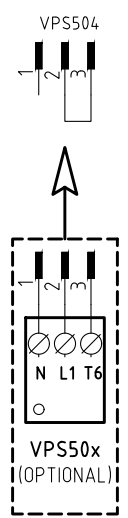
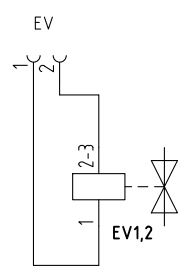
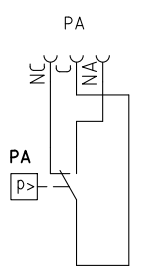
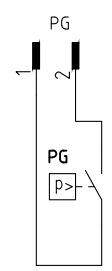
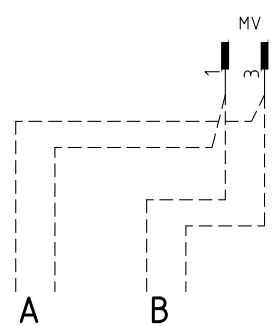
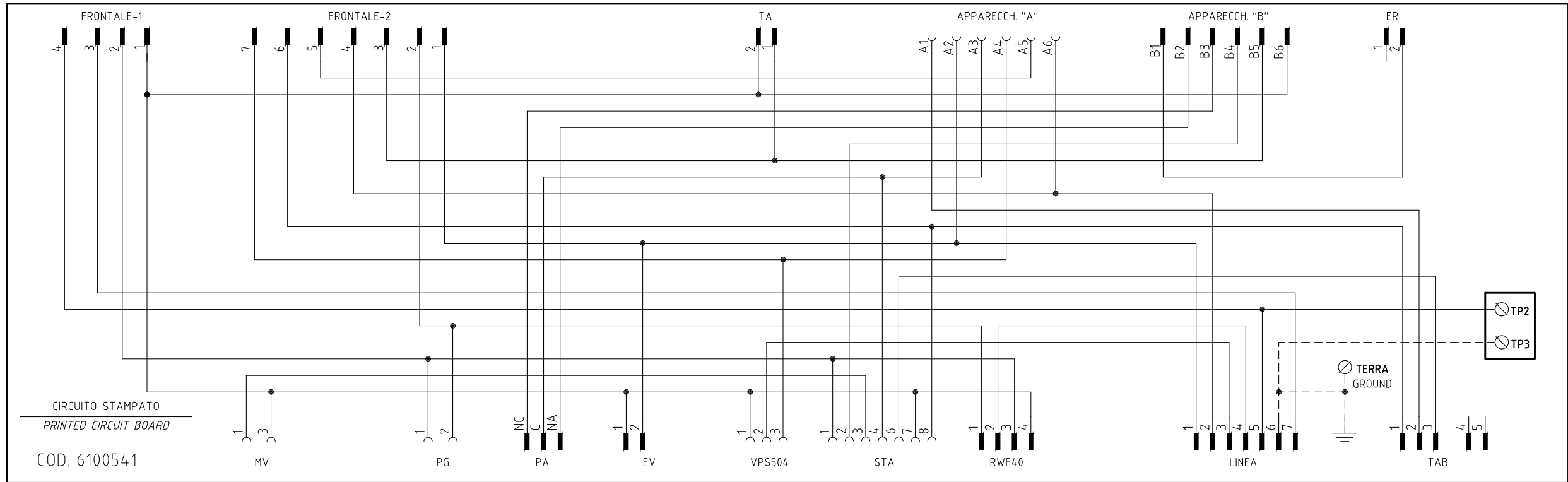
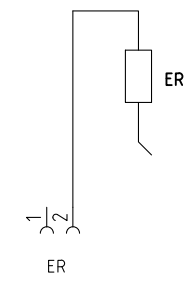
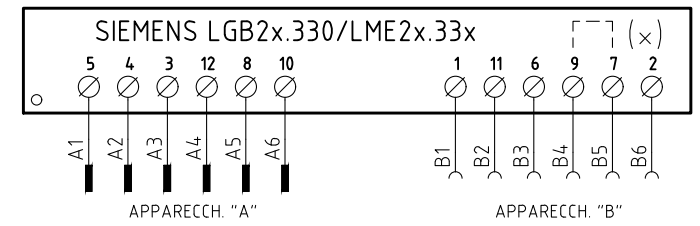
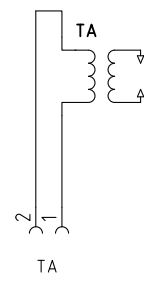
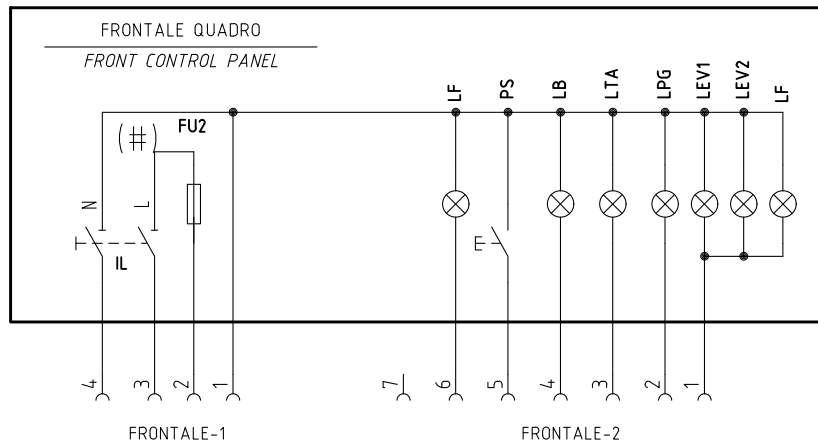

- (#) MOTORE VENTIL. VERSIONE [A], FU2 = 6,3A F; MOTORE VENTIL. VERSIONE [B], FU2 = 10A F
FAN MOTOR VERSION [A], FU2= 6,3 A F;
FAN MOTOR VERSION [B], FU2= 10 A F
- (x) FARE PONTE TRA I MORSETTI 7 E 9 SOLO CON LGB21.330
CONNECTION BETWEEN TERMINALS 7 AND 9 WITH LGB21.330 ONLY
- (xxx) SOLO CON ALIMENTAZIONE ELETTRICA SENZA NEUTRO
WITH ELECTRIC SUPPLY WITHOUT NEUTRAL VERSION ONLY

Data	19/10/2010	PREC.	FOGLIO
Revisione	06	/	1
Dis. N.	18 - 0163	SEGUE	TOTALE
		2	5

VERSIONE ALTA-BASSA FIAMMA "AB" / PROGRESSIVO "PR"
 "AB" HIGH-LOW / "PR" PROGRESSIVE VERSION

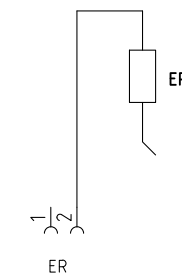
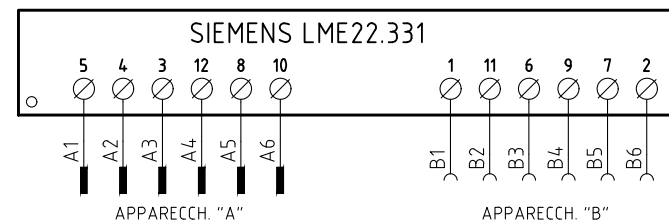
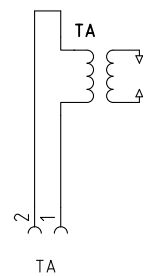
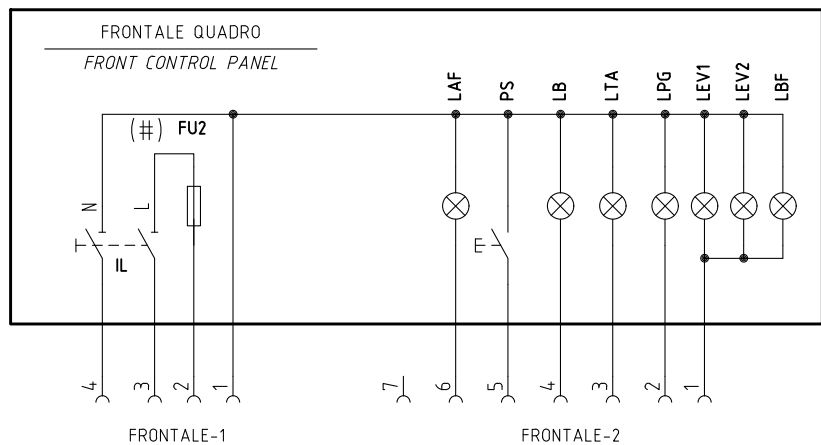

SERVOCOMANDO SERRANDA ARIA
 AIR DAMPER ACTUATOR
 STA13B0.36/83N30L
 I ALTA FIAMMA
 II HIGH FLAME
 SOSTA
 STAND-BY
 III BASSA FIAMMA
 IV LOW FLAME
 NON USATA
 NOT USED

SERVOCOMANDO SERRANDA ARIA
 AIR DAMPER ACTUATOR
 SIEMENS SQN72.xA4A20
 I (ROSSO) ALTA FIAMMA
 I (RED) HIGH FLAME
 II (BLU) SOSTA
 II (BLUE) STAND-BY
 III (ARANCIO) BASSA FIAMMA
 III (ORANGE) LOW FLAME
 IV (NERO) NON USATA
 IV (BLACK) NOT USED

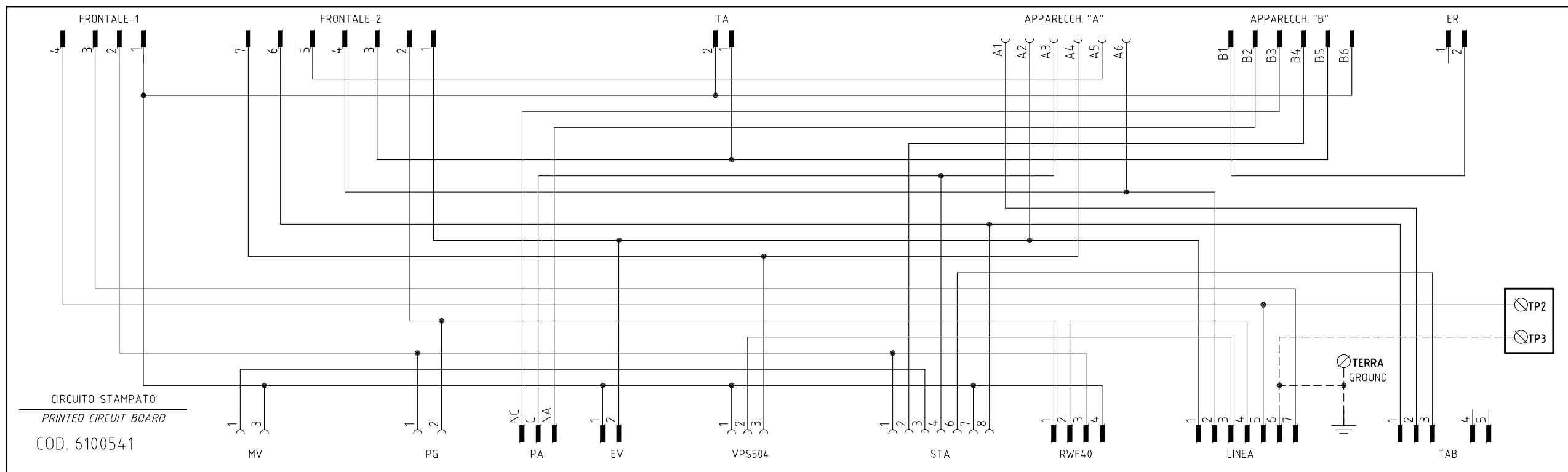

CIRCUITO STAMPATO
 PRINTED CIRCUIT BOARD
 COD. 6100541

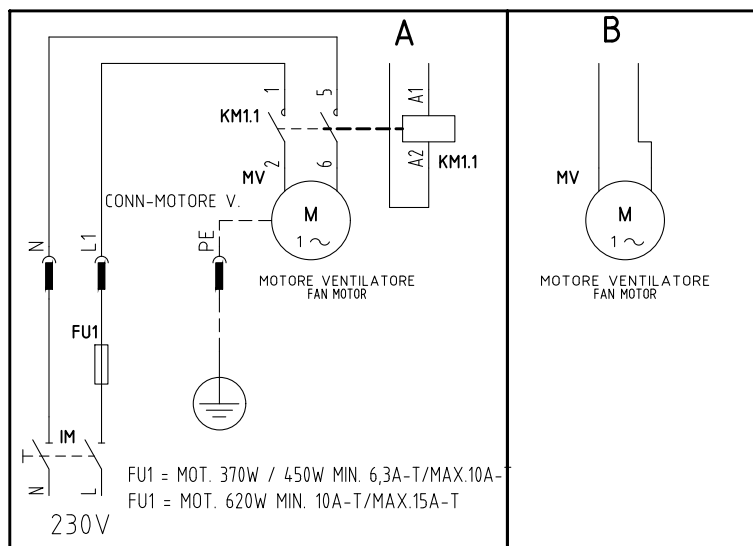
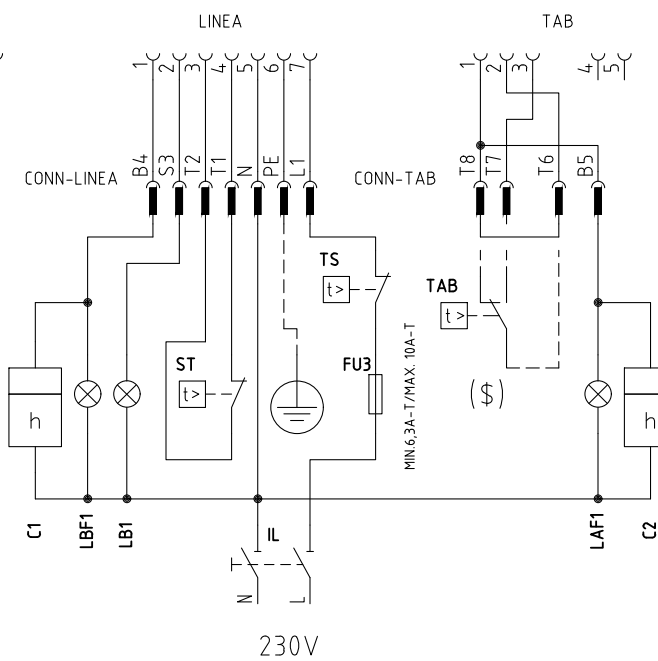
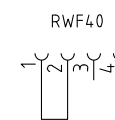
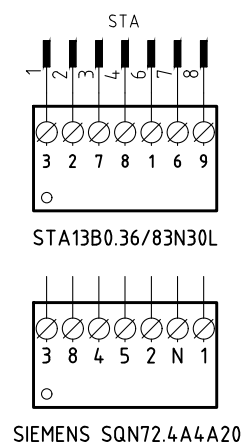
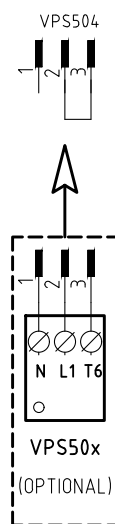
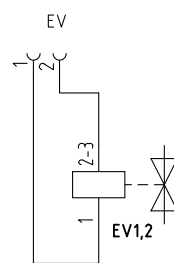
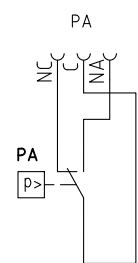
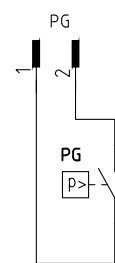
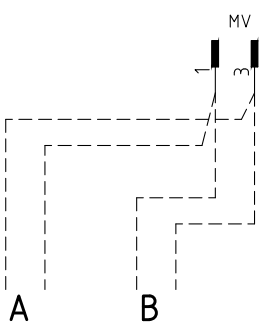

- (#) MOTORE VENTIL. VERSIONE [A], FU2 = 6,3A F; MOTORE VENTIL. VERSIONE [B], FU2 = 10A F
 FAN MOTOR VERSION [A], FU2= 6,3 A F;
 FAN MOTOR VERSION [B], FU2= 10 A F
- (x x x) SOLO CON ALIMENTAZIONE ELETTRICA SENZA NEUTRO
 WITH ELECTRIC SUPPLY WITHOUT NEUTRAL VERSION ONLY
- (\$) SE USATO "TAB", TOGLIERE IL PONTE TRA I MORSETTI T6-T8
 IF USED "TAB", REMOVE THE BRIDGE BETWEEN TERMINALS T6-T8

Data	19/10/2010	PREC.	FOGLIO
Revisione	06	1	2
Dis. N.	18 - 0163	3	5

VERSIONE MODULANTE "MD"
"MD" MODULATING VERSION

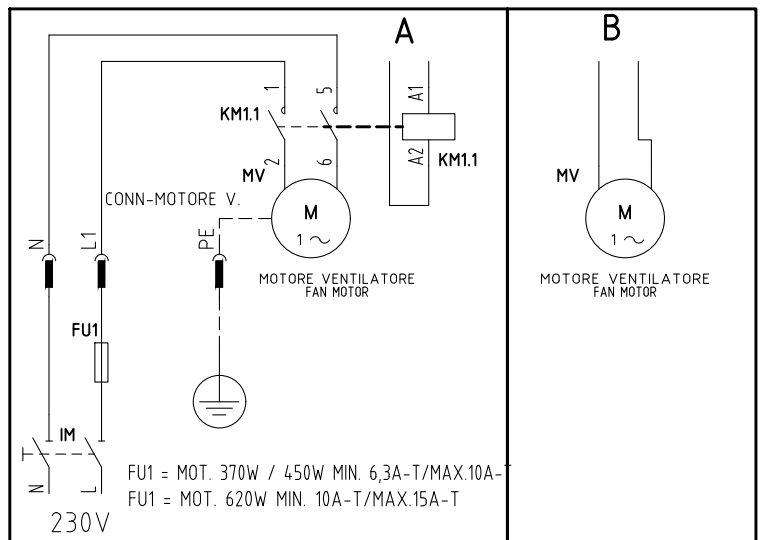
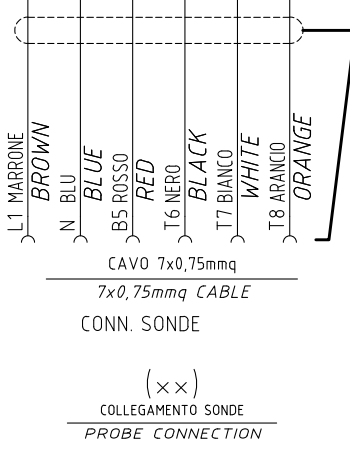
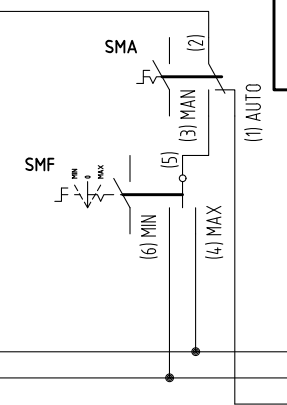
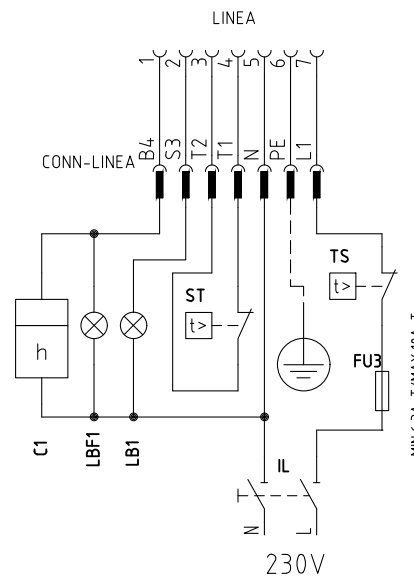
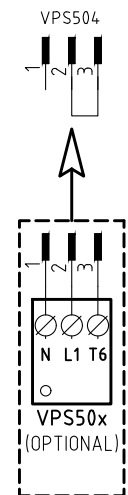
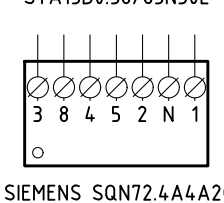
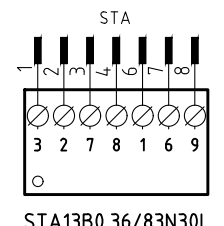
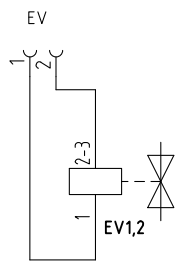
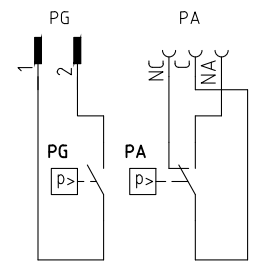
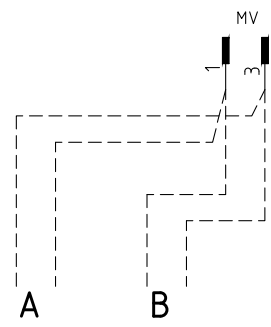
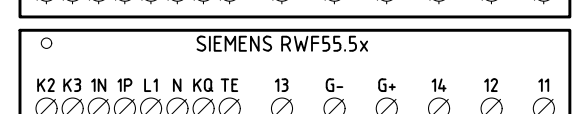
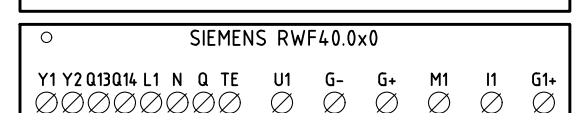
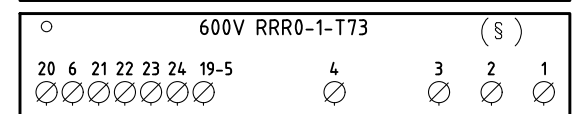
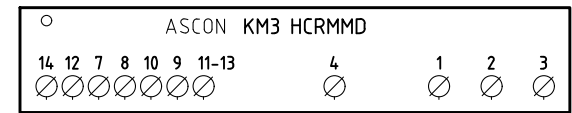
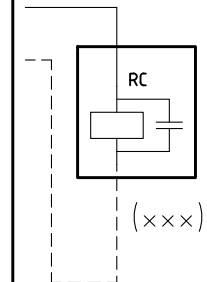
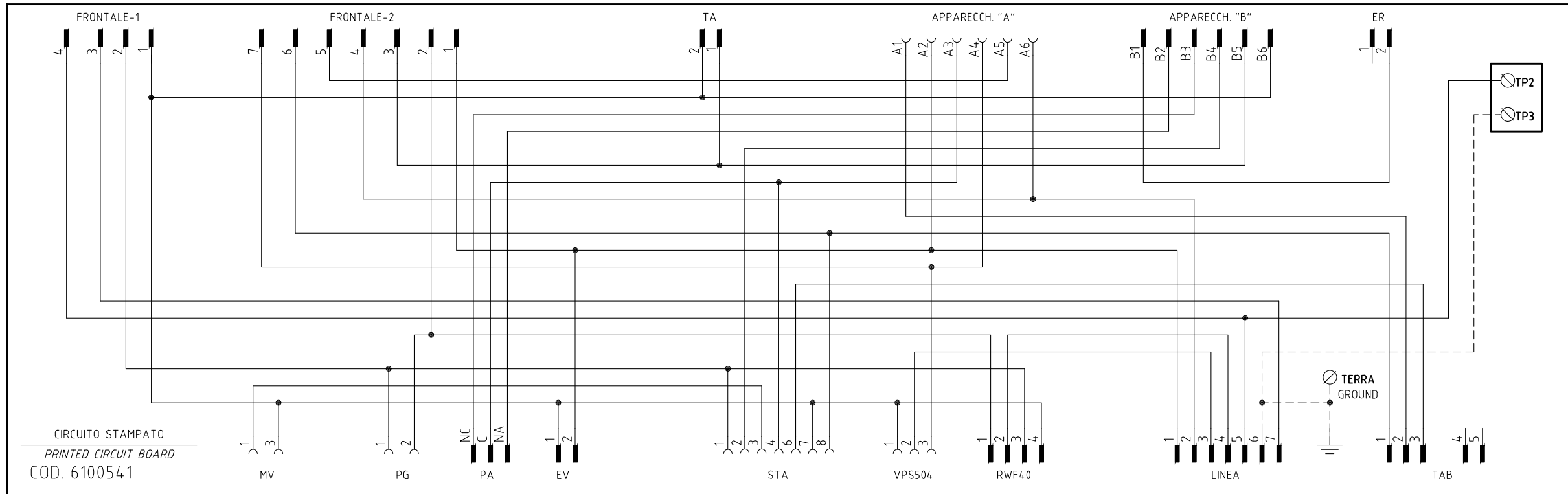
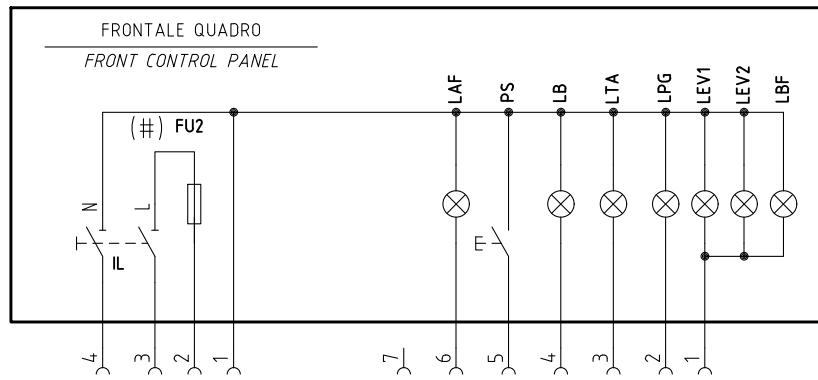

SERVOCOMANDO SERRANDA ARIA
AIR DAMPER ACTUATOR
STA13B0.36/83N30L
I ALTA FIAMMA HIGH FLAME
II SOSTA STAND-BY
IV BASSA FIAMMA LOW FLAME
III NON USATA NOT USED

SERVOCOMANDO SERRANDA ARIA
AIR DAMPER ACTUATOR
SIEMENS SQN72.xA4A20
I (ROSSO) ALTA FIAMMA HIGH FLAME
II (BLU) SOSTA STAND-BY
III (ARANCIO) BASSA FIAMMA LOW FLAME
IV (NERO) NON USATA NOT USED

(#) MOTORE VENTIL. VERSIONE [A], FU2 = 6,3A F; MOTORE VENTIL. VERSIONE [B], FU2 = 10A F
FAN MOTOR VERSION [A], FU2= 6,3 A F;
FAN MOTOR VERSION [B], FU2= 10 A F

(x x x) SOLO CON ALIMENTAZIONE ELETTRICA SENZA NEUTRO
WITH ELECTRIC SUPPLY WITHOUT NEUTRAL VERSION ONLY

Data	19/10/2010	PREC.	FOGLIO
Revisione	06	2	3
Dis. N.	18 - 0163	SEGUE	TOTALE
		4	5

(xx)
 ATTENZIONE COLLEGAMENTO SONDE CON CONNETTORE 7 POLI
 WARNING PROBE CONNECTION WITH 7 PINS CONNECTOR

KM3 HCRMMD

600V RRR0-1-T73

RWF55.5x

RWF50.2x

RWF40.0xx

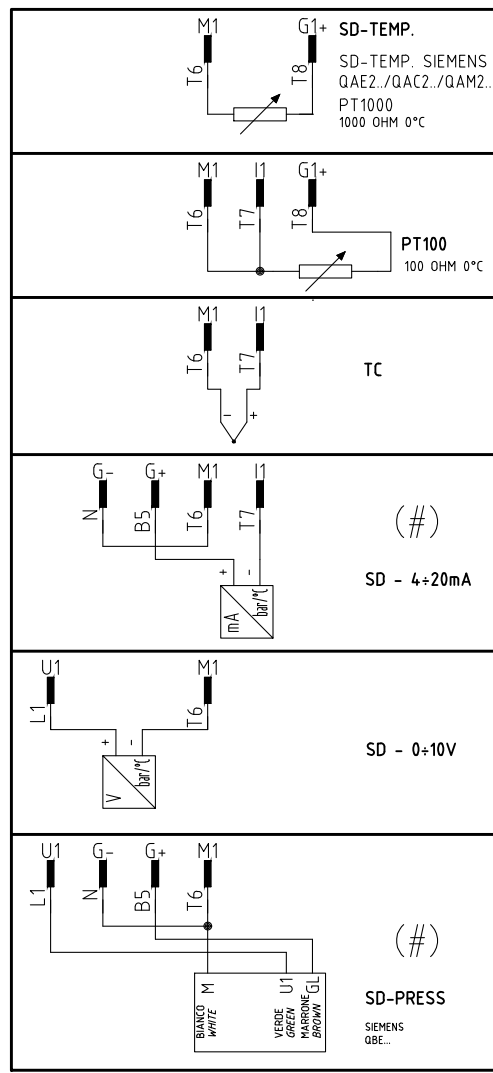
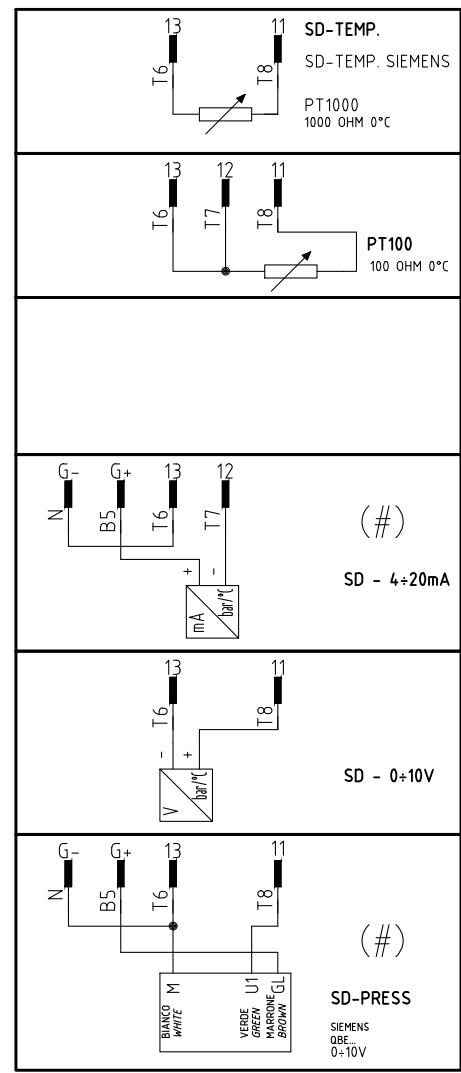
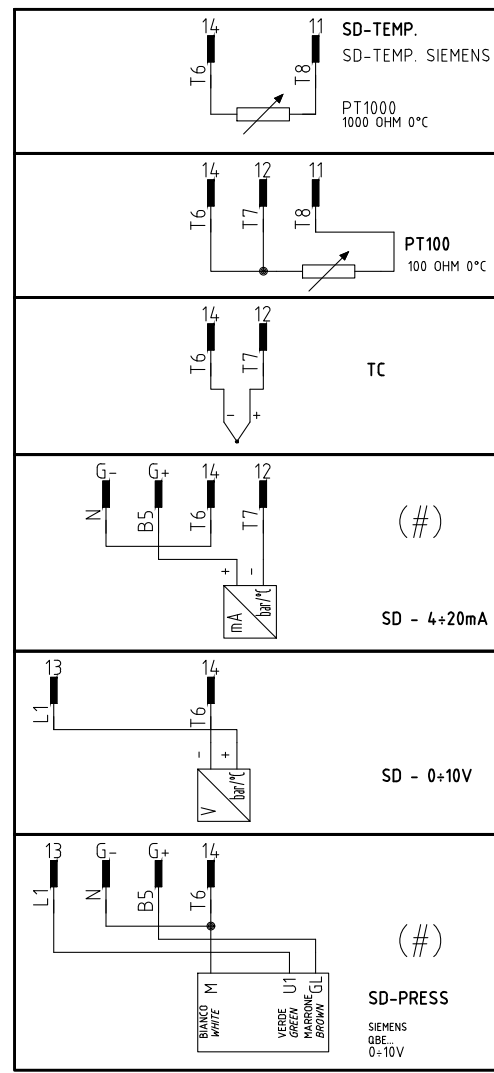
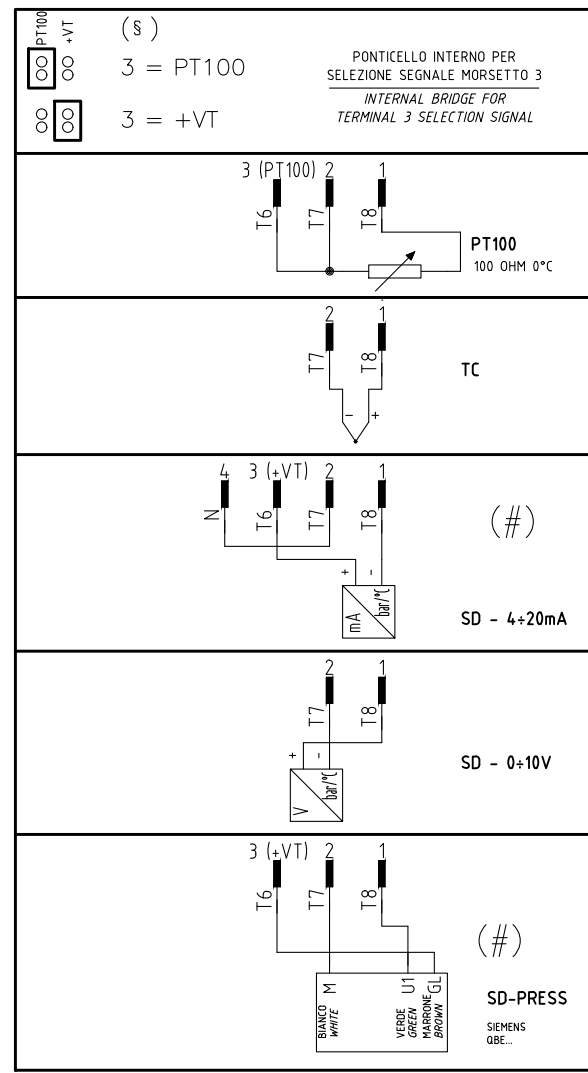
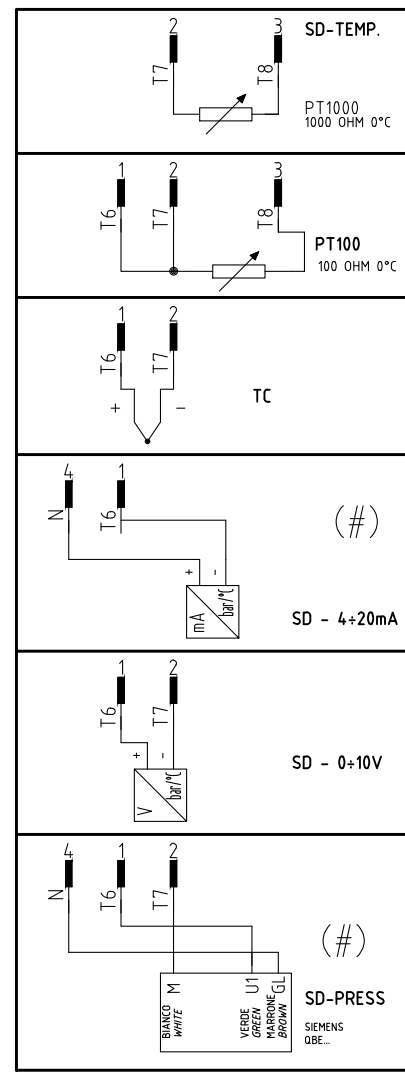

(#)
 COLLEGAMENTO SOLO PER TRASDUTTORI PASSIVI
 TRANSDUCER PASSIVE CONNECTION ONLY

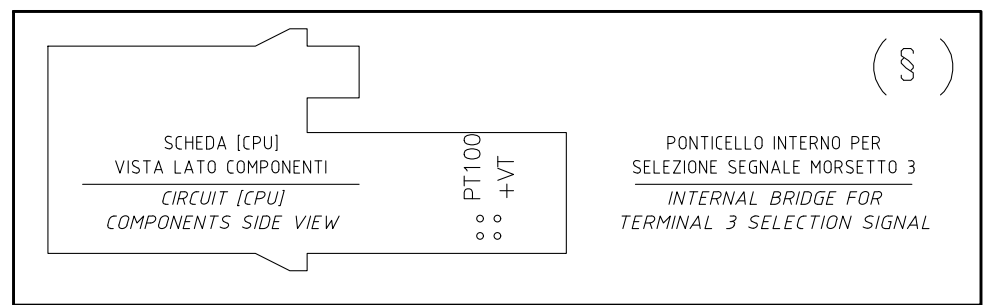
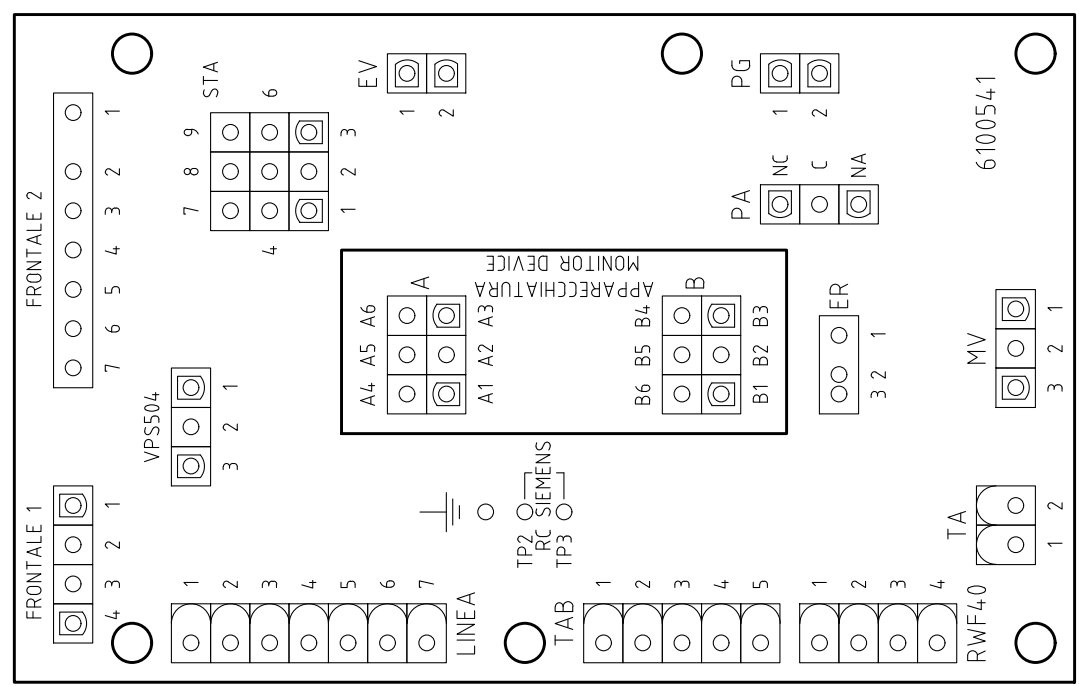

Data	19/10/2010	PREC.	FOGLIO
Revisione	06	3	4
Dis. N.	18 - 0163	SEGUE	TOTALE
		5	5

Sigla/Item	Funzione	Function
600V RRR0-1-T73	REGOLATORE MODULANTE (ALTERNATIVO)	BURNER MODULATOR (ALTERNATIVE)
C1	CONTAORE BASSA FIAMMA	LOW FLAME TIME COUNTER
C2	CONTAORE ALTA FIAMMA	HIGH FLAME TIME COUNTER
ER	ELETTRODO RILEVAZIONE FIAMMA	FLAME DETECTION ELECTRODE
EV1,2	ELETTROVALVOLE GAS (O GRUPPO VALVOLE)	GAS ELECTRO-VALVES (OR VALVES GROUP)
FU1	FUSIBILE LINEA MOTORE VENTILATORE	FAN MOTOR LINE FUSE
FU2	FUSIBILE DI LINEA	LINE FUSE
FU3	FUSIBILE LINEA BRUCIATORE	BURNER LINE FUSE
FU4	FUSIBILE AUSILIARIO	AUXILIARY FUSE
IL	INTERRUTTORE LINEA AUSILIARI	AUXILIARY LINE SWITCH
IM	INTERRUTTORE LINEA MOTORE VENTILATORE	FAN MOTOR LINE SWITCH
KM1.1	CONTATTORE MOTORE VENTILATORE	FAN MOTOR CONTACTOR
KM3 HCRMMD	REGOLATORE MODULANTE (ALTERNATIVO)	BURNER MODULATOR (ALTERNATIVE)
LAF	LAMPADA SEGNALAZIONE ALTA FIAMMA BRUCIATORE	BURNER IN HIGH FLAME INDICATOR LIGHT
LAF1	LAMPADA SEGNALAZIONE ALTA FIAMMA BRUCIATORE	BURNER IN HIGH FLAME INDICATOR LIGHT
LB	LAMPADA SEGNALAZIONE BLOCCO BRUCIATORE	INDICATOR LIGHT FOR BURNER LOCK-OUT
LB1	LAMPADA SEGNALAZIONE BLOCCO BRUCIATORE	INDICATOR LIGHT FOR BURNER LOCK-OUT
LBF	LAMPADA SEGNALAZIONE BASSA FIAMMA BRUCIATORE	BURNER IN LOW FLAME INDICATOR LIGHT
LBF1	LAMPADA SEGNALAZIONE BASSA FIAMMA BRUCIATORE	BURNER IN LOW FLAME INDICATOR LIGHT
LEV1	LAMPADA SEGNALAZIONE APERTURA [EV1]	INDICATOR LIGHT FOR OPENING OF ELECTRO-VALVE [EV1]
LEV2	LAMPADA SEGNALAZIONE APERTURA [EV2]	INDICATOR LIGHT FOR OPENING OF ELECTRO-VALVE [EV2]
LF	LAMPADA SEGNALAZIONE FUNZIONAMENTO BRUCIATORE	INDICATOR LIGHT BURNER OPERATION
LPG	LAMPADA SEGNALAZIONE PRESENZA GAS IN RETE	INDICATOR LIGHT FOR PRESENCE OF GAS IN THE NETWORK
LTA	LAMPADA SEGNALAZIONE TRASFORMATORE DI ACCENSIONE	IGNITION TRANSFORMER INDICATOR LIGHT
MV	MOTORE VENTILATORE	FAN MOTOR
PA	PRESSOSTATO ARIA	AIR PRESSURE SWITCH
PG	PRESSOSTATO GAS DI MINIMA PRESSIONE	MINIMUM GAS PRESSURE SWITCH
PS	PULSANTE SBLOCCO FIAMMA	FLAME UNLOCK BUTTON
PT100	SONDA DI TEMPERATURA	TEMPERATURE PROBE
RC	CIRCUITO RC	RC CIRCUIT
SD-PRESS	SONDA DI PRESSIONE	PRESSURE PROBE
SD-TEMP.	SONDA DI TEMPERATURA	TEMPERATURE PROBE
SD - 0÷10V	TRASDUTTORE USCITA IN TENSIONE	TRANSDUCER VOLTAGE OUTPUT
SD - 4÷20mA	TRASDUTTORE USCITA IN CORRENTE	TRANSDUCER CURRENT OUTPUT
SIEMENS LGB2x.330/LME2x.33x	APPARECCHIATURA CONTROLLO FIAMMA	CONTROL BOX
SIEMENS LME22.331	APPARECCHIATURA CONTROLLO FIAMMA	CONTROL BOX
SIEMENS LME22.331	APPARECCHIATURA CONTROLLO FIAMMA	CONTROL BOX
SIEMENS RWF40.0x0	REGOLATORE MODULANTE	BURNER MODULATOR
SIEMENS RWF50.2x	REGOLATORE MODULANTE	BURNER MODULATOR
SIEMENS RWF55.5x	REGOLATORE MODULANTE (ALTERNATIVO)	BURNER MODULATOR (ALTERNATIVE)
SIEMENS SQN72.4A4A20	SERVOCOMANDO SERRANDA ARIA (ALTERNATIVO)	AIR DAMPER ACTUATOR (ALTERNATIVE)
SMA	SELETTORE MANUALE/AUTOMATICO	MANUAL/AUTOMATIC SWITCH
SMF	SELETTORE MANUALE FUNZIONAMENTO MIN-0-MAX	MIN-0-MAX MANUAL OPERATION SWITCH
ST	SERIE TERMOSTATI/PRESSOSTATI	SERIES OF THERMOSTATS OR PRESSURE SWITCHES
STA13B0.36/83N30L	SERVOCOMANDO SERRANDA ARIA	AIR DAMPER ACTUATOR
TA	TRASFORMATORE DI ACCENSIONE	IGNITION TRANSFORMER
TAB	TERMOSTATO/PRESSOSTATO ALTA-BASSA FIAMMA	HIGH-LOW THERMOSTAT/PRESSURE SWITCHES
TC	TERMOCOPPIA	THERMOCOUPLE
TS	TERMOSTATO/PRESSOSTATO DI SICUREZZA	SAFETY THERMOSTAT OR PRESSURE SWITCH
VPS50x	CONTROLLO DI TENUTA VALVOLE GAS (OPTIONAL)	GAS PROVING SYSTEM (OPTIONAL)

Data	19/10/2010	PREC.	FOGLIO
Revisione	06	4	5
Dis. N.	18 - 0163	SEGUE	TOTALE
		/	5

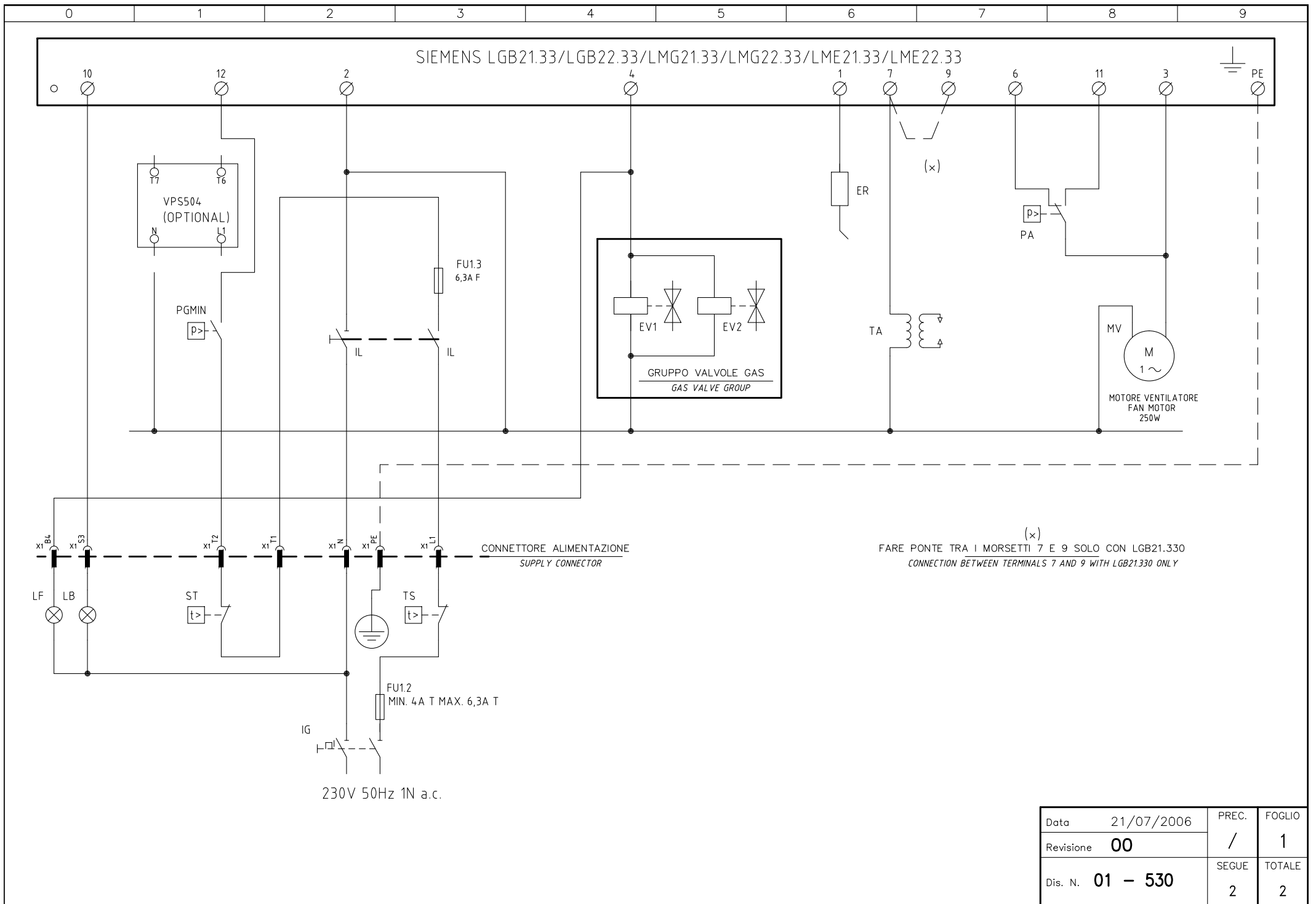

Data	21/07/2006	PREC.	FOGLIO
Revisione	00	/	1
Dis. N.	01 - 530	SEGUE	TOTALE
		2	2

SIGLA/ITEM	FOGLIO/SHEET	FUNZIONE	FUNCTION
ER	1	ELETTRODO RIVELAZIONE FIAMMA	FLAME DETECTION ELECTRODE
EV1	1	ELETTROVALVOLA GAS LATO RETE (O GRUPPO VALVOLE)	GAS ELECTRO-VALVE UPSTREAM (OR VALVES GROUP)
EV2	1	ELETTROVALVOLA GAS LATO BRUCIATORE (O GRUPPO VALVOLE)	GAS ELECTRO-VALVE DOWNSTREAM (OR VALVES GROUP)
FU1.2	1	FUSIBILE DI LINEA	LINE FUSE
FU1.3	1	FUSIBILE AUSILIARIO	AUXILIARY FUSE
IG	1	INTERRUTTORE GENERALE	MAIN DISCONNECTOR
IL	1	INTERRUTTORE LINEA BRUCIATORE	BURNER LINE SWITCH
LB	1	LAMPADA SEGNALAZIONE BLOCCO BRUCIATORE	INDICATOR LIGHT FOR BURNER LOCK-OUT
LF	1	LAMPADA SEGNALAZIONE FUNZIONAMENTO BRUCIATORE	INDICATOR LIGHT BURNER OPERATION
MV	1	MOTORE VENTILATORE	FAN MOTOR
PA	1	PRESSOSTATO ARIA COMBURENTE	COMBUSTION AIR PRESSURE SWITCH
PGBIN	1	PRESSOSTATO GAS DI MINIMA PRESSIONE	MINIMUM GAS PRESSURE SWITCH
SIEMENS LGB../LMG../LME..	1	APPARECCHIATURA CONTROLLO FIAMMA	FLAME MONITOR DEVICE
ST	1	SERIE TERMOSTATI/PRESSOSTATI	SERIES OF THERMOSTATS OR PRESSURE SWITCHES
TA	1	TRASFORMATORE DI ACCENSIONE	IGNITION TRANSFORMER
TS	1	TERMOSTATO/PRESSOSTATO DI SICUREZZA	SAFETY THERMOSTAT OR PRESSURE SWITCH
VPS504	1	CONTROLLO DI TENUTA VALVOLE GAS (OPTIONAL)	GAS LEAKAGE MONITOR DEVICE (OPTIONAL)

Data	21/07/2006	PREC.	FOGLIO
Revisione	00	1	2
Dis. N.	01 - 530	SEGUE	TOTALE
		/	2

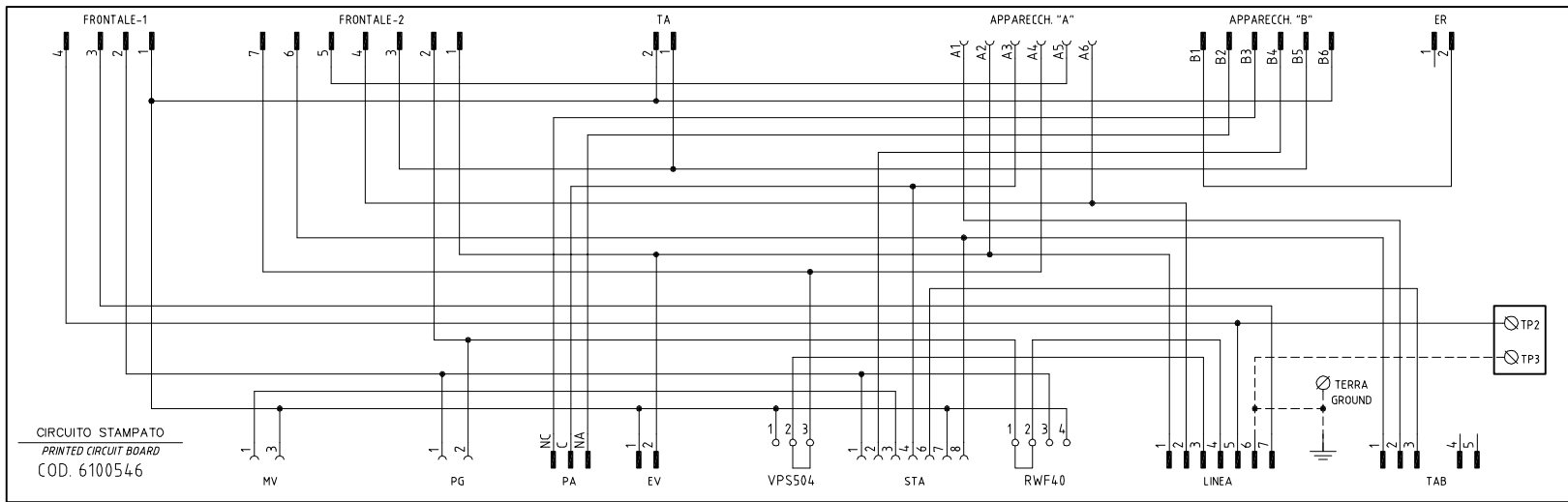
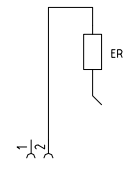
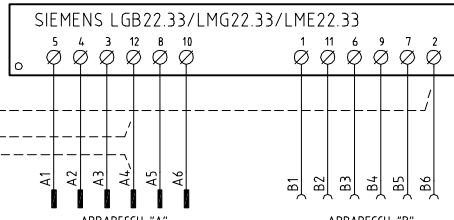
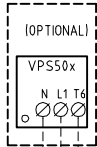
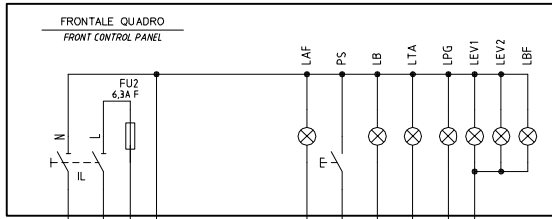

CIRCUITO STAMPATO
PRINTED CIRCUIT BOARD
COD. 6100546

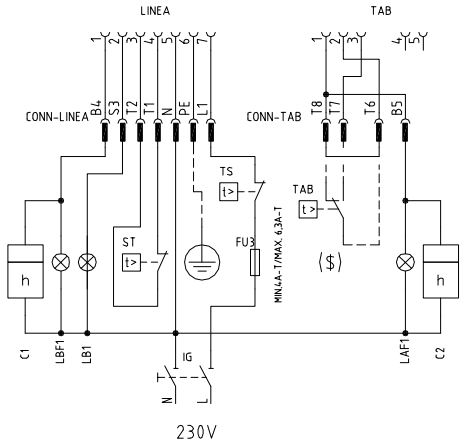
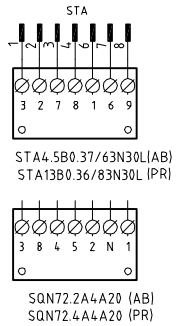
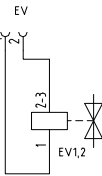
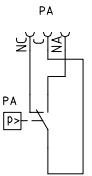
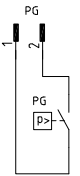
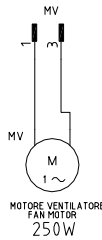

CAMME SERVOCOMANDO SERRANDA ARIA VERSIONE (AB)
CAMS OF AIR DAMPER ACTUATOR VERSION (AB)
STA4.5B0.37/63N30L / STA13B0.36/83N30L

I ALTA FIAMMA HIGH FLAME
II SOSTA STAND-BY
IV BASSA FIAMMA LOW FLAME
III (ARANCIO) NON USATA NOT USED

CAMME SERVOCOMANDO SERRANDA ARIA VERSIONE (PR)
CAMS OF AIR DAMPER ACTUATOR VERSION (PR)
SQN72.xA4A20

I (ROSSO) ALTA FIAMMA HIGH FLAME
II (VERDE) SOSTA STAND-BY
III (BLAU) SOSTA STAND-BY
III (ARANCIO) BASSA FIAMMA LOW FLAME
IV (NERO) NON USATA NOT USED

(xxx) SOLO CON ALIMENTAZIONE ELETTRICA SENZA NEUTRO
WITH ELECTRIC SUPPLY WITHOUT NEUTRAL VERSION ONLY

(\$) SE USATO "TAB", TOGLIERE IL PONTE TRA I MORSETTI T6-T8
IF USED "TAB", REMOVE THE BRIDGE BETWEEN TERMINALS T6-T8

Data	21/07/2006	PREC.	FOGLIO
Revisione	01	/	1
Dis. N.	18 - 103	SEQUE	TOTALE
		2	2

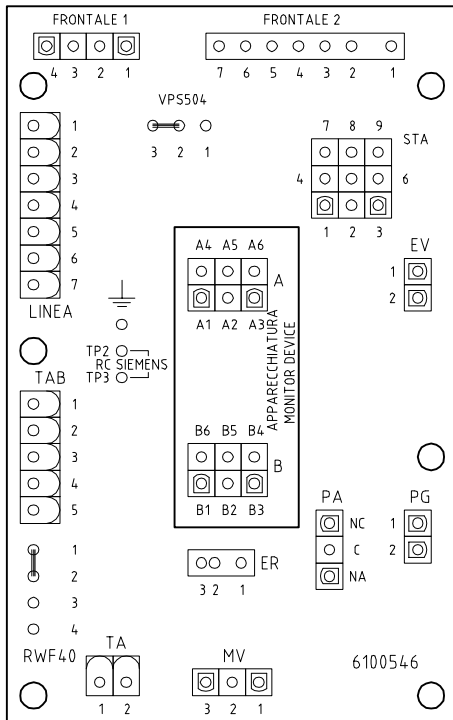

SIGLA/ITEM	FUNZIONE	FUNCTION
C1	CONTAORE BASSA FIAMMA	LOW FLAME TIME COUNTER
C2	CONTAORE ALTA FIAMMA	HIGH FLAME TIME COUNTER
ER	ELETTRODO RILEVAZIONE FIAMMA	FLAME DETECTION ELECTRODE
EV1,2	ELETTROVALVOLE GAS (O GRUPPO VALVOLE)	GAS ELECTRO-VALVES (OR VALVES GROUP)
FU2	FUSIBILE DI LINEA	LINE FUSE
FU3	FUSIBILE LINEA BRUCIATORE	BURNER LINE FUSE
IG	INTERRUTTORE LINEA BRUCIATORE	BURNER LINE SWITCH
IL	INTERRUTTORE LINEA AUSILIARI	AUXILIARY LINE SWITCH
LAF	LAMPADA SEGNALE ALTA FIAMMA BRUCIATORE	BURNER IN HIGH FLAME INDICATOR LIGHT
LAF1	LAMPADA SEGNALE ALTA FIAMMA BRUCIATORE	BURNER IN HIGH FLAME INDICATOR LIGHT
LB	LAMPADA SEGNALE BLOCCO BRUCIATORE	INDICATOR LIGHT FOR BURNER LOCK-OUT
LB1	LAMPADA SEGNALE BLOCCO BRUCIATORE	INDICATOR LIGHT FOR BURNER LOCK-OUT
LBF	LAMPADA SEGNALE BASSA FIAMMA BRUCIATORE	BURNER IN LOW FLAME INDICATOR LIGHT
LBF1	LAMPADA SEGNALE BASSA FIAMMA BRUCIATORE	BURNER IN LOW FLAME INDICATOR LIGHT
LEV1	LAMPADA SEGNALE APERTURA (EV1)	INDICATOR LIGHT FOR OPENING OF ELECTRO-VALVE [EV1]
LEV2	LAMPADA SEGNALE APERTURA (EV2)	INDICATOR LIGHT FOR OPENING OF ELECTRO-VALVE [EV2]
LPG	LAMPADA SEGNALE PRESENZA GAS IN RETE	INDICATOR LIGHT FOR PRESENCE OF GAS IN THE NETWORK
LTA	LAMPADA SEGNALE TRASFORMATORE DI ACCENSIONE	IGNITION TRANSFORMER INDICATOR LIGHT
MV	MOTORE VENTILATORE	FAN MOTOR
PA	PRESSOSTATO ARIA	AIR PRESSURE SWITCH
PG	PRESSOSTATO GAS DI MINIMA PRESSIONE	MINIMUM GAS PRESSURE SWITCH
PS	PULSANTE SBLOCCO FIAMMA	LOCK-OUT RESET BUTTON
RC	CIRCUITO RC	RC CIRCUIT
SIEMENS LGB22.33/LMG22.33/LME22.33	APPARECCHIATURA CONTROLLO FIAMMA	CONTROL BOX
SQN72.2A4A20	SERVOCOMANDO SERRANDA ARIA VERSIONE [AB]	AIR DAMPER ACTUATOR VERSION [AB]
SQN72.4A4A20	SERVOCOMANDO SERRANDA ARIA VERSIONE [PR]	AIR DAMPER ACTUATOR VERSION [PR]
ST	SERIE TERMOSTATI/PRESSOSTATI	SERIES OF THERMOSTATS OR PRESSURE SWITCHES
STA4.5B0.37/63N30L	SERVOCOMANDO SERRANDA ARIA VERSIONE [AB]	AIR DAMPER ACTUATOR VERSION [AB]
STA13B0.36/83N30L	SERVOCOMANDO SERRANDA ARIA VERSIONE [PR]	AIR DAMPER ACTUATOR VERSION [PR]
TA	TRASFORMATORE DI ACCENSIONE	IGNITION TRANSFORMER
TAB	TERMOSTATO/PRESSOSTATO ALTA-BASSA FIAMMA	HIGH-LOW THERMOSTAT/PRESSURE SWITCHES
TS	TERMOSTATO/PRESSOSTATO DI SICUREZZA	SAFETY THERMOSTAT OR PRESSURE SWITCH
VPS50x	CONTROLLO DI TENUTA VALVOLE GAS (OPTIONAL)	GAS PROVING SYSTEM (OPTIONAL)

Data	21/07/2006	PREC.	FOGLIO
Revisione	01	1	2
Dis. N.	18 - 103	SEQUE	TOTALE
		/	2

BURNER EXPLODED VIEW NG280

Position	Description
1	VALVE GROUP
3	COVER FIXING SCREW
7	FIXING BRACKET - LEFT SIDE
8	FIXING BRACKET - RIGHT SIDE
10	COVER
11	4-WAYS FAIRLEAD
12	2-WAYS FAIRLEAD
13	FAIRLEAD
14	FASTENER
15.1	GAS PRESSURE INTAKE
15.2	HOUSING
15.3	FLANGED COUPLING
15.4	MOTOR'S PLATE
15.5	WASHER
16	GASKET
17	AIR DAMPER INDEX
18	EXTENSION SCREW
19	FAN
20	GAS PRESSURE SWITCH
21	MOTOR
22	VALVE GROUP FLANGE
23	GAS PROVING SYSTEM
25	AIR FLAP
26	AIR DAMPER CRANK (progressive and fully modulating only)
27	FIXING ROD
30	PANEL ASSEMBLY
34	GREY/GREEN TERMINAL
35	BLACK/GREEN TERMINAL
36	BLOCKING PLATE
37.1	COMPONENTS BRACKET
37.2	ELECTRONIC BOARD
37.3	ACTUATOR (double stage, progressive and fully modulating only)
37.4	AIR PRESSURE SWITCH
37.5	CONTROL BOX BOARD
37.6	CONTROL BOX
37.7	GAS TRANSFORMER
38	BOX ASSEMBLY
41	BLAST TUBE
42.1	BUTTERFLY MANIFOLD
42.12	IGNITION CABLE
42.13	DETECTION CABLE
42.17.1	IGNITION ELECTRODE
42.17.2	DETECTION ELECTRODE
42.17.3	GROUNDING CABLE
42.17.5	COMBUSTION HEAD
43	GAS PIPE
44	OR RING

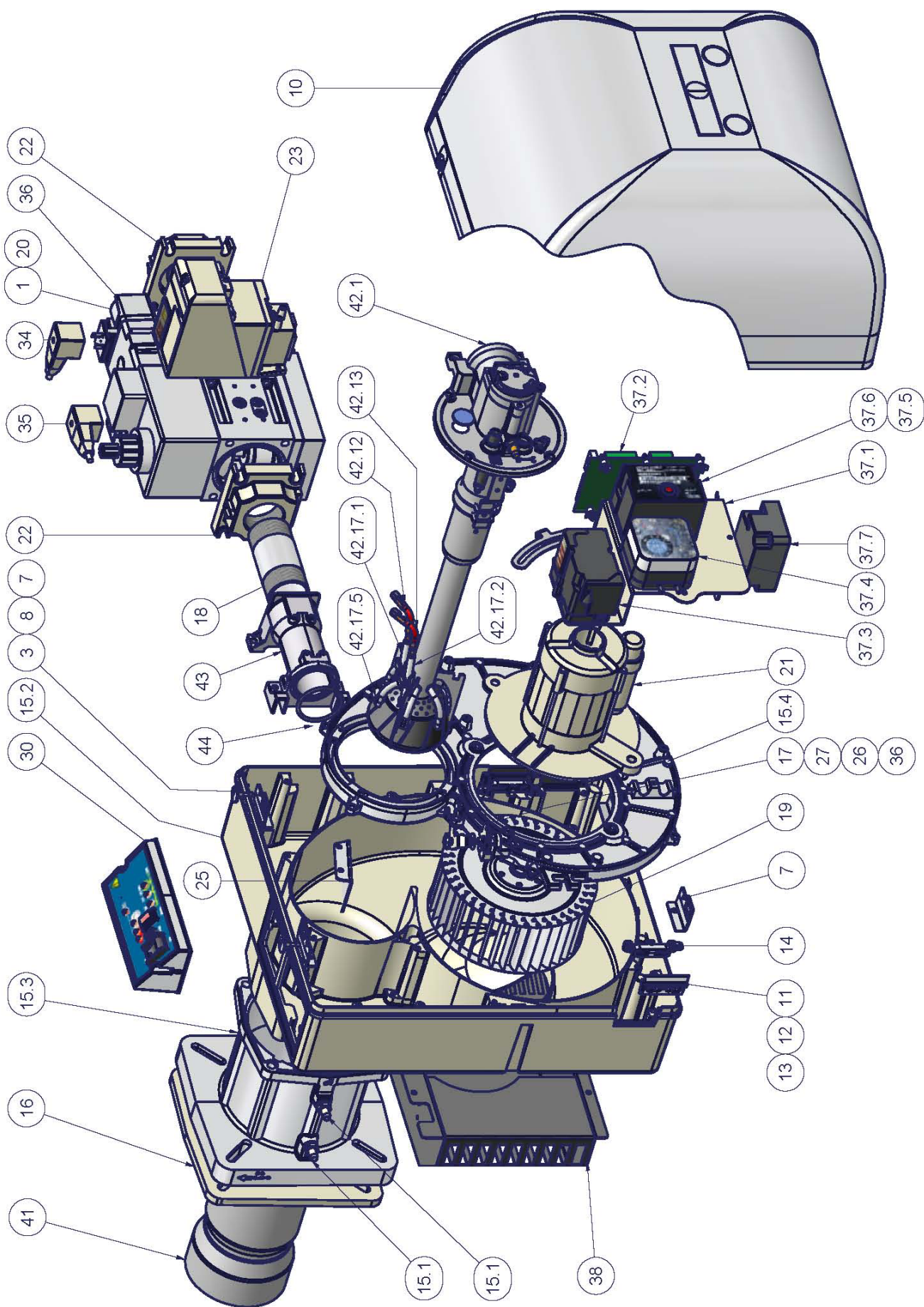

BURNER EXPLODED VIEW NG350-400

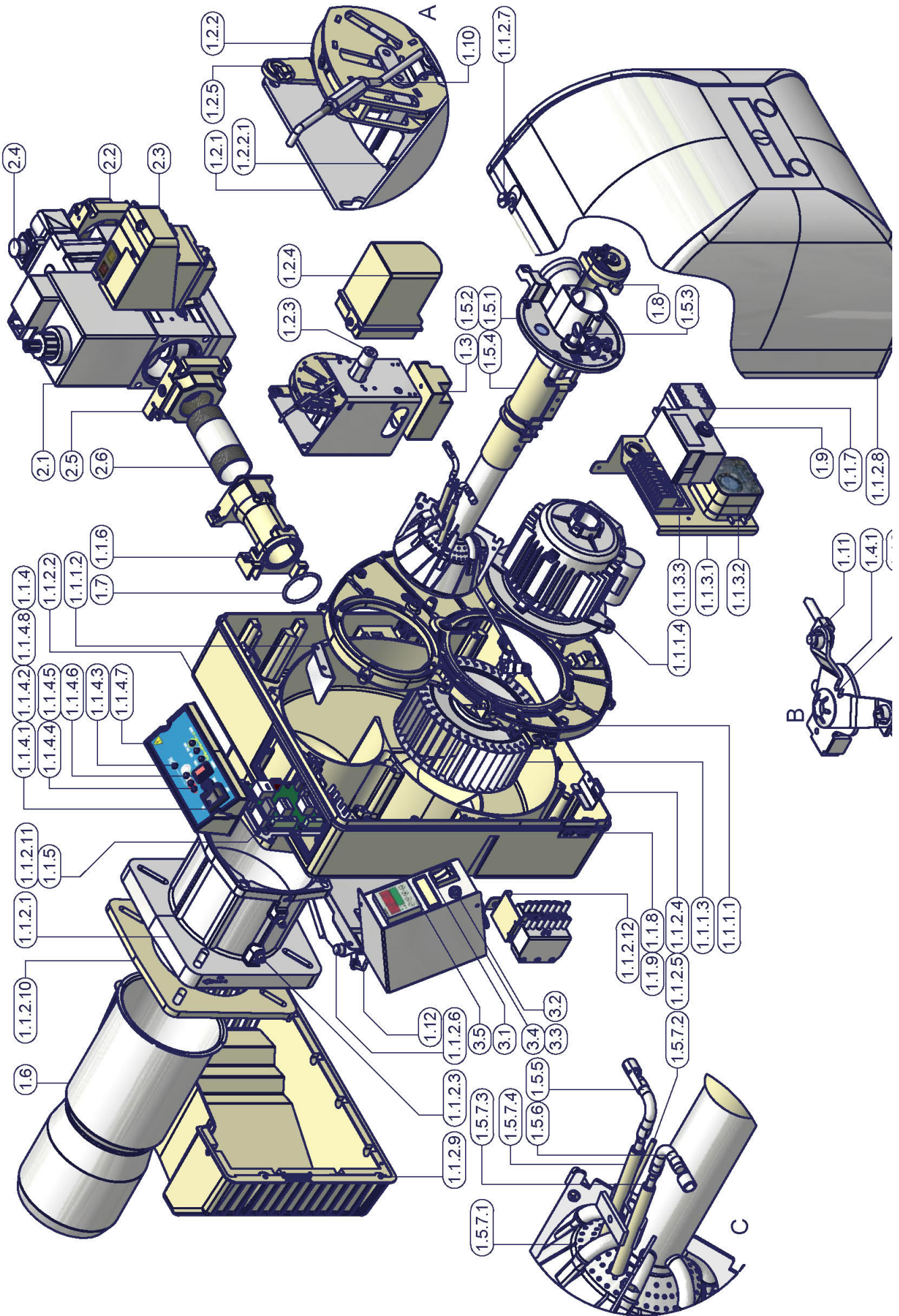

BURNER EXPLODED VIEW NG350-400

Position	Description
1	VALVE GROUP
2	WASHER
3	COVER FIXING SCREW
4	AIR DAMPER ASSEMBLY
5	BOX ASSEMBLY
6	BOARD'S SUPPORTING BRACKET
7	FIXING BRACKET - LEFT SIDE
8	FIXING BRACKET - RIGHT SIDE
9	BLAST TUBE
10	COVER
11	4-WAYS FAIRLEAD
12	2-WAYS FAIRLEAD
13	FAIRLEAD
14	FASTENER
15.1	GAS PRESSURE INTAKE
15.2	HOUSING
15.3	FLANGED COUPLING
15.4	MOTOR'S PLATE
15.5	WASHER
16	GASKET
17	AIR DAMPER INDEX
18	EXTENSION SCREW
19	FAN
20	GAS PRESSURE SWITCH
21	MOTOR
22	VALVE GROUP FLANGE
23	GAS PROVING SYSTEM
24	OR RING
25	AIR FLAP
26	AIR DAMPER CRANK (progressive and fully modulating only)
27	FIXING ROD
28	GAS PIPE
29.1	GAS TRANSFORMER
29.2	SMALL ADJUSTING CAM
29.3	ACTUATOR (double stage, progressive and fully modulating only)
30	PANEL ASSEMBLY
31.1	CONTROL BOX BRACKET
31.2	AIR PRESSURE SWITCH
31.3.1	CONTROL BOX
31.3.2	CONTROL BOX BOARD
31.4	CONTACTOR
32.1	BUTTERFLY MANIFOLD
32.2	HEAD EXTENSION ASSEMBLY
32.3	BUTTERFLY ASSEMBLY
32.4.1	COMBUSTION HEAD
32.4.2	DETECTION ELECTRODE
32.4.3	IGNITION ELECTRODE
32.5	IGNITION CABLE
32.6	DETECTION CABLE
33	ELECTRONIC BOARD
34	GREY/GREEN TERMINAL
35	BLACK/GREEN TERMINAL
36	BLOCKING PLATE

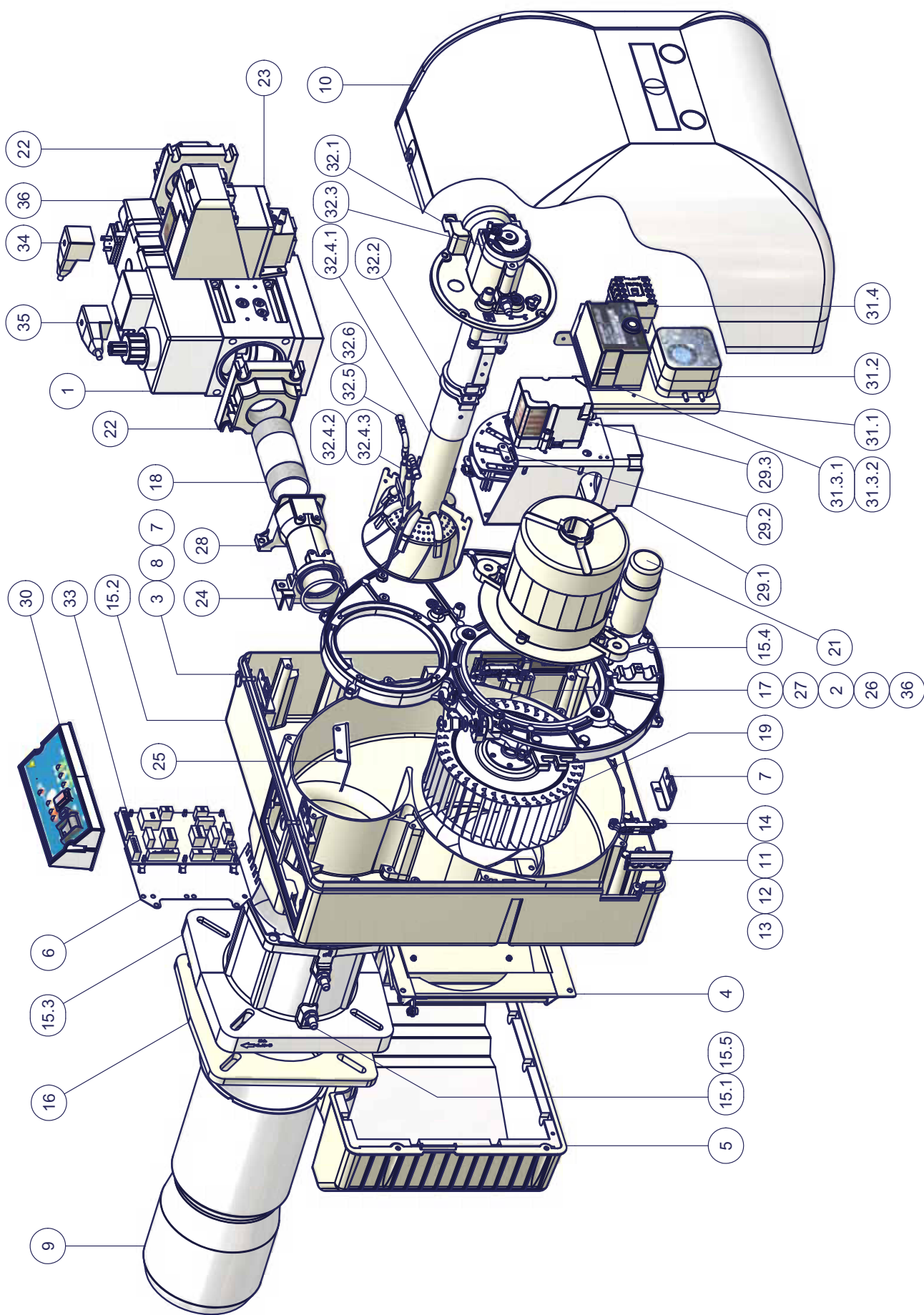

LME11 control sequence

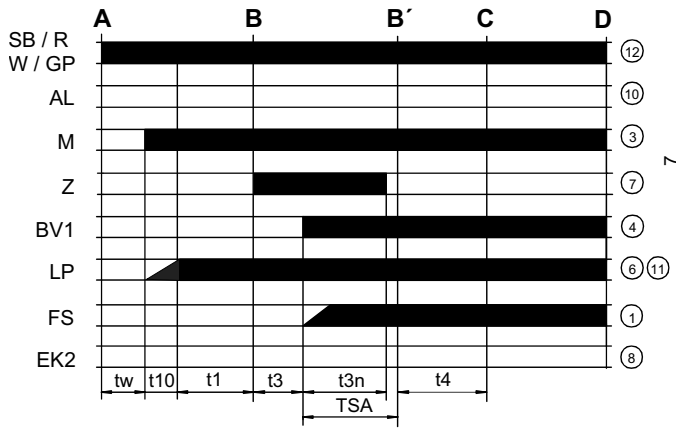

LME21 control sequence

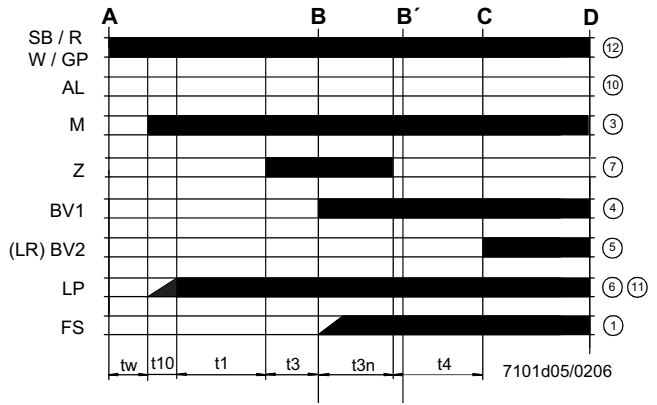

LME22 control sequence

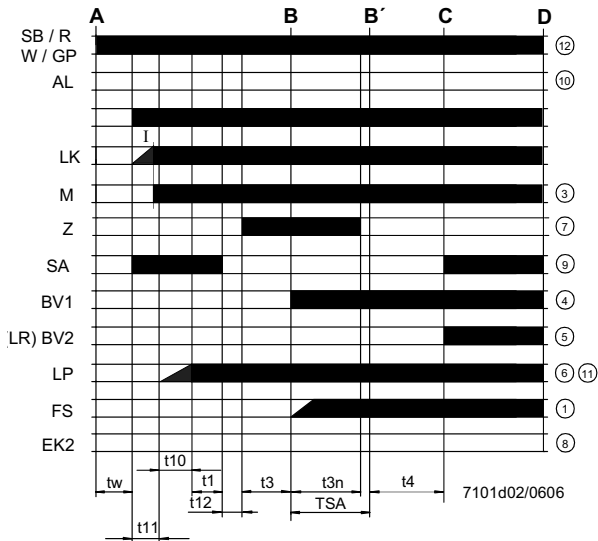

Control sequence

- t_w Waiting time
- t_1 Purge time
- TSA Ignition safety time
- t_3 Preignition time
- t_{3n} Postignition time
- t_4 Interval between BV1 and BV2/LR
- t_{10} Specified time for air pressure signal
- t_{11} Programmed opening time for actuator SA
- t_{12} Programmed closing time for actuator SA

LME11 connection diagram

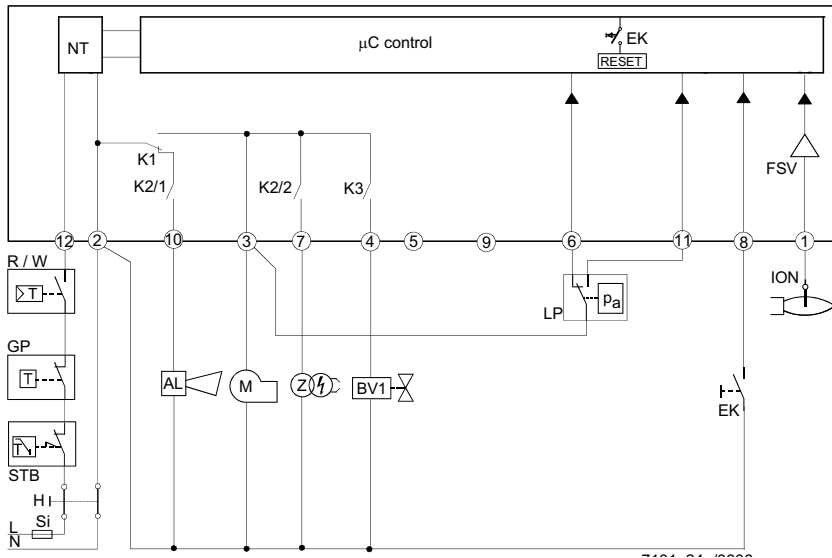

Connection diagram

- AL Error message (alarm)
- BV Fuel valve
- EK2 Remote lockout reset button
- FS Flame signal
- GP Gas pressure switch
- LP Air pressure switch
- LR Load controller
- M Fan motor
- R Control thermostat/pressurestat
- SB Safety limit thermostat
- W Limit thermostat /pressure switch
- Z Ignition transformer

LME21 connection diagram

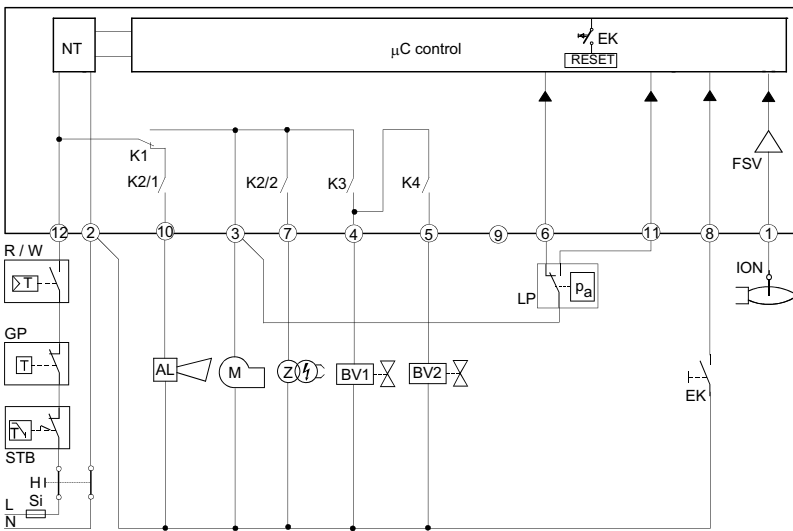

LME22 connection diagram

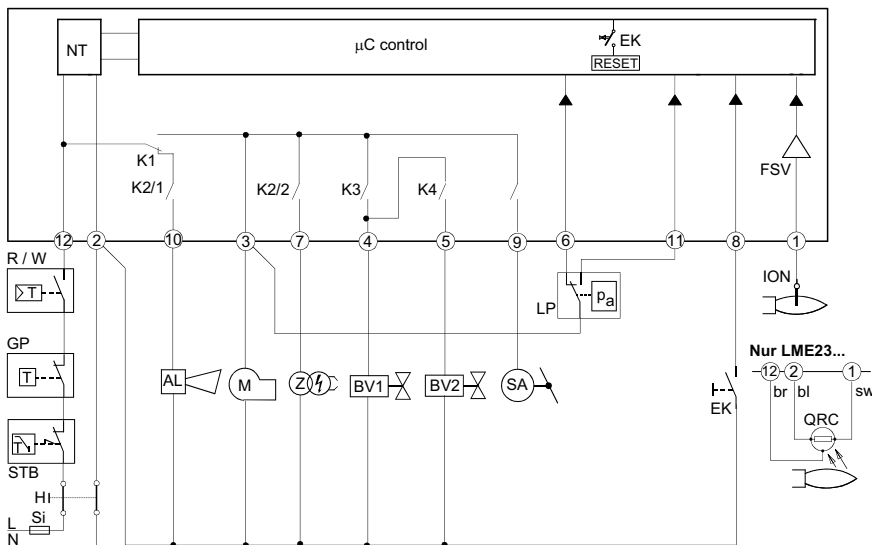

CONTROL PROGRAM IN THE EVENT OF FAULT

- If a fault occurs, all outputs will immediately be deactivated (in less than 1s).
- After an interruption of power, a restart will be made with the full program sequence.
- If the operating voltage drops below the undervoltage threshold, a safety shutdown is performed.
- If the operating voltage exceeds the undervoltage threshold, a restart will be performed.
- In case of extraneous light during "t1", a lockout occurs.
- In case of extraneous light during "tw", there is a prevention of startup and a lockout after 30 seconds.
- In case of no flame at the end of TSA, there will be max. 3 repetitions of the startup cycle, followed by a lockout at the end of TSA, for mod. LME11..; directly a lockout at the end of TSA for LME21-22 models.
- For LME11 model: if a loss of flame occurs during operation, in case of an establishment of flame at the end of TSA, there will be max. 3 repetitions, otherwise a lockout will occur.
- For LME21-22 models: if a loss of flame occurs during operation, there will be a lockout.
- If the contact of air pressure monitor LP is in working position, a prevention of startup and lockout after 65 seconds will occur.
- If the contact of air pressure monitor LP is in normal position, a lockout occurs at the end of t10.
- If no air pressure signal is present after completion of t1, a lockout will occur.

CONTROL BOX LOCKED

In the event of lockout, the LME.. remains locked and the red signal lamp (LED) will light up. The burner control can immediately be reset. This state is also maintained in the case of mains failure.

DIAGNOSTICS OF THE CASE OF FAULT

- Press the lockout reset button for more than 3 seconds to activate the visual diagnostics.
- Count the number of blinks of the red signal lamp and check the fault condition on the "Error code table" (the device repeats the blinks for regular intervals).

During diagnostics, the control outputs are deactivated:

- the burner remains shut down;
- external fault indication is deactivated;
- fault status is showed by the red LED, inside the LME's lockout reset button according to the "Error code table":

ERROR CODE TABLE	
2 blinks **	No establishment of flame at the end of TSA - Faulty or soiled fuel valves - Faulty or soiled flame detector - Inadequate adjustment of burner, no fuel - Faulty ignition equipment
3 blinks ***	The air pressure switch does not switch or remains in idle position: - LP is faulty - Loss of air pressure signal after t10 - LP is welded in normal position.
4 blinks ****	- Extraneous light when burner starts up.
5 blinks *****	- LP is working position.
6 blinks *****	Free.
7 blinks *****	Loss of flame during operation - Faulty or soiled fuel valves - Faulty or soiled flame detector - Inadequate adjustment of burner
8 ÷ 9 blinks	Free
10 blinks *****	Faulty output contacts Attention: "lockout" remote signal (terminal no. 10) not enabled - Wiring error - Anomalous voltage on output terminals - Other faults
14 blinks ***** (only for LME4x)	- CPI contact (gas valve microswitch) not closed.

RESETTING THE BURNER CONTROL

When lockout occurs, the burner control can immediately be reset, by pressing the lockout reset button for about 1..3 seconds. The LME.. can only be reset when all contacts in the line are closed and when there is no undervoltage.

LIMITATION OF REPETITIONS (only for LME11.. model)

If no flame is established at the end of TSA, or if the flame is lost during operation, a maximum of 3 repetitions per controller startup can be performed via "R", otherwise lockout will be initiated. Counting of repetitions is restarted each time a controlled startup via "R" takes place.

⚠ Condensation, formation of ice and ingress of water are not permitted!

TECHNICAL CHARACTERISTICS

Mains voltage	120V AC +10% / -15% 230V AC +10% / -15%
Frequency	50 ... 60 Hz +/- 6%
Power consumption	12VA
External primary fuse	max. 10 A (slow)
input current at terminal 12	max. 5 A
Detection cable length	max. 3m (for electrode)
Detection cable length	max. 20 m (laid separately, for QRA probe)
Reset cable length	max. 20 m (posato separatamente)
Term. 8 & 10 cable length	max. 20 m
Thermostat cable length and other terminals	max. 3 m
Safety class	I
Index of protection	IP40 (to be ensured during mounting)
Operating conditions	-20... +60 °C, < 95% UR
Storage conditions	-20... +60 °C, < 95% UR
Weight	approx. 160 g



C.I.B. UNIGAS S.p.A.
Via L.Galvani, 9 - 35011 Campodarsego (PD) - ITALY
Tel. +39 049 9200944 - Fax +39 049 9200945/9201269
web site: www.cibunigas.it - e-mail: cibunigas@cibunigas.it

Note: specifications and data subject to change. Errors and omissions exceptd.



CIB UNIGAS

LG/NG/NGX280

LG/NG/NGX350

LG/NG/NGX400

WIRING DIAGRAMS

ELECTRICAL WIRING DIAGRAMS

Electric wiring diagrams

Wiring diagram 18-163 - Complete key

C1	LOW FLAME TIME METER
C2	HIGH FLAME TIME METER
ER	FLAME DETECTION ELECTRODE
EV1,2	GAS ELECTRO-VALVES (OR VALVES GROUP)
FU1	FAN MOTOR LINE FUSE
FU2	LINE FUSE
FU3	LINE FUSE
FU4	AUXILIARY FUSE
IL	BURNER LINE SWITCH
IM	FAN MOTOR LINE SWITCH
KM1	FAN MOTOR CONTACTOR
LAF	BURNER IN HIGH FLAME INDICATOR LIGHT
LB	INDICATOR LIGHT FOR BURNER LOCK-OUT
LBF	BURNER IN LOW FLAME INDICATOR LIGHT
LEV1	INDICATOR LIGHT FOR OPENING OF ELECTRO-VALVE EV2
LEV2	INDICATOR LIGHT FOR OPENING OF ELECTRO-VALVE EV2
LF	INDICATOR LIGHT BURNER FUNCTIONING
LGB2x.330/LMG2x330	CONTROL BOX
LPG	INDICATOR LIGHT FOR PRESENCE OF GAS IN THE NETWORK
LTA	IGNITION TRANSFORMER INDICATOR LIGHT
MV	FAN MOTOR
PA	COMBUSTION AIR PRESSURE SWITCH
PG	MINIMUM GAS PRESSURE SWITCH
PS	LOCK-OUT RESET BUTTON
PT100	TEMPERATURE PROBE
RC	RC CIRCUIT
SATRONIC DLG976	CONTROL BOX
SATRONIC DMG972	CONTROL BOX
SD-0÷10V	VOLTAGE SIGNAL
SD-0/4÷20mA	CURRENT SIGNAL
SD-PRESS	PRESSURE PROBE
SD-TEMP	TEMPERATURE PROBE
SIEMENS LME..	CONTROL BOX
SIEMENS RWF40	MODULATORSMANUAL/AUTOMATIC SELECTOR
SMF	MIN-0-MAX FUNCTIONING MANUAL SELECTOR
ST	SERIES OF THERMOSTATS OR PRESSURE SWITCHES
STA/SQN72	AIR DAMPER ACTUATOR
TA	IGNITION TRANSFORMER
TAB	HIGH-LOW THERMOSTAT/PRESSURE SWITCHES
TC	THERMOCOUPLE
TS	SAFETY THERMOSTAT OR PRESSURE SWITCH
VPS504	GAS PROVING SYSTEM (OPTIONAL)
(#)	FAN MOTOR 620 W D 450W, FU2= 6,3 A F; FAN MOTOR 370 W , FU2= 10 A F
(*)	BRIDGE BETWEEN TERMINALS7 AND 9 ONLY WITH LGB21.330 (SINGLE STAGE VERSION ONLY)
(**)	SEE PROBE CONNECTION
(***)	WITH ELECTRIC SUPPLY WITHOUT NEUTRAL VERSION ONLY
(\$)	IF "TAB" USED REMOVE THE BRIDGE BETWEEN TERMINALS T6-T8

WARNING:

- 1 - Electrical supply 230V 50/60Hz 1N a.c.
- 2 - Do not reverse phase with neutral
- 3 - Ensure burner is properly earthed

LG/NG/NGX 280 Single stage - Electric wiring diagrams - SE01-530

LG/NG/NGX 280 Double stage - Progressive - Electric wiring diagrams - SE18-103

LG/NG/NGX 350-400 Electric wiring diagrams - SE18-163

LG/NG/NGX 350-400 Electric wiring diagrams - SE18-057

SE00_TAB1-1

KEYS

C1	LOW FLAME TIME COUNTER	LAF	BURNER IN HIGH FLAME INDICATOR LIGHT
C2	HIGH FLAME TIME COUNTER	LB	INDICATOR LIGHT FOR BURNER LOCK-OUT
FU1	FAN MOTOR LINE FUSE	LBF	BURNER IN LOW FLAME INDICATOR LIGHT
FU3	BURNER LINE FUSE	ST	SERIES OF THERMOSTATS OR PRESSURE SWITCHES
IL	BURNER LINE SWITCH	TAB	HIGH-LOW THERMOSTAT/PRESSURE SWITCHES
IM	FAN MOTOR LINE SWITCH	TS	SAFETY THERMOSTAT OR PRESSURE SWITCH
KAB	AUXILIARY RELAY		

SIEMENS LGB21.33/LGB22.33/LMG21.33/LMG22.33/LME21.33/LME22.33

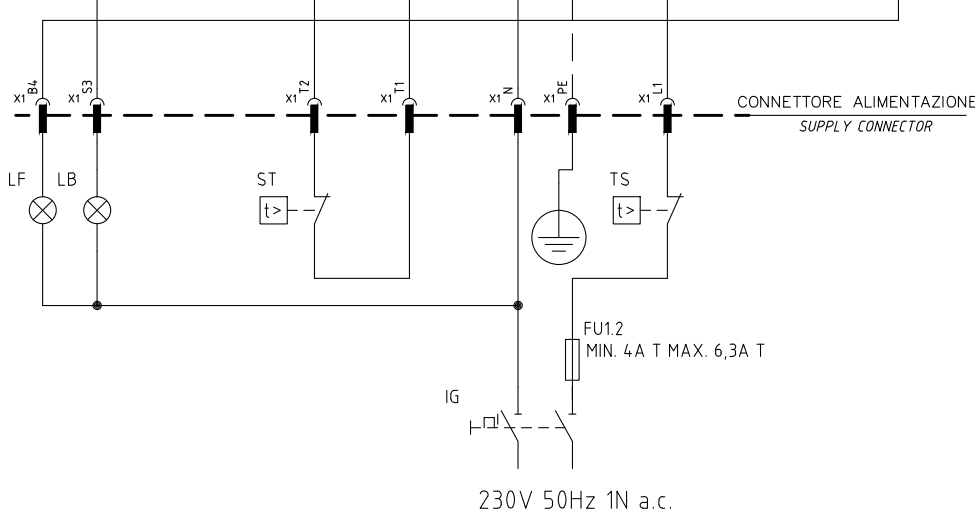
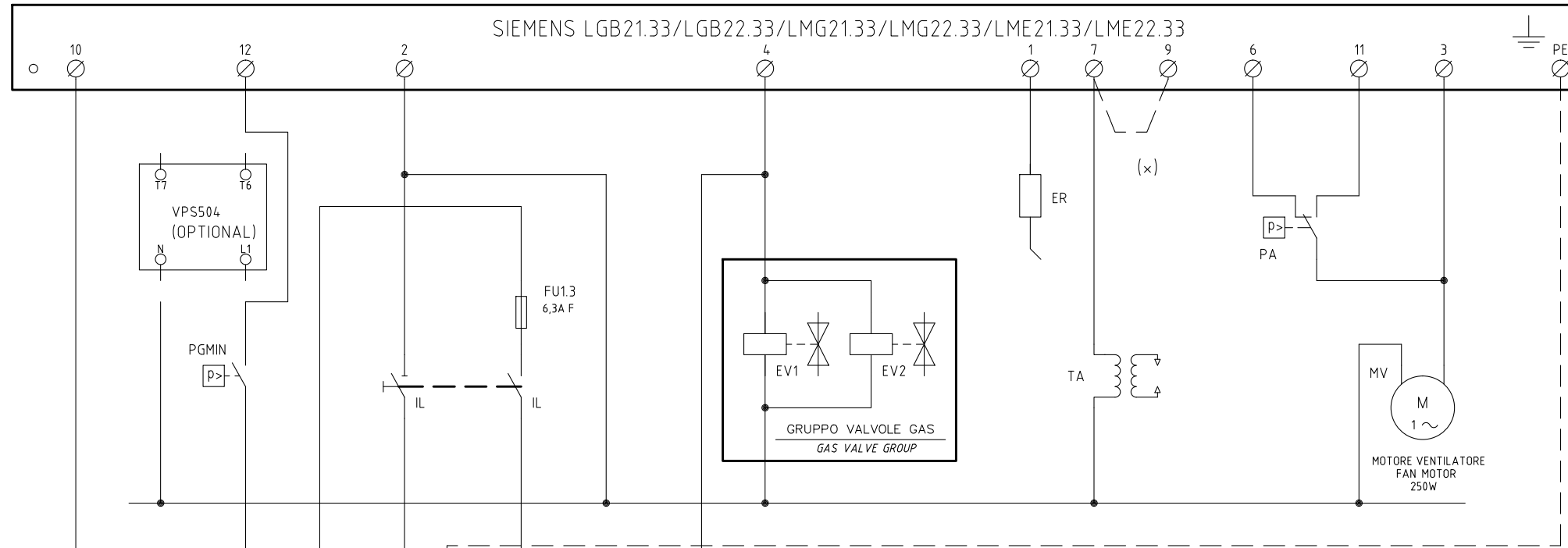

(x)
FARE PONTE TRA I MORSETTI 7 E 9 SOLO CON LGB21.330
CONNECTION BETWEEN TERMINALS 7 AND 9 WITH LGB21.330 ONLY

Data	21/07/2006	PREC.	FOGLIO
Revisione	00	/	1
Dis. N.	01 - 530	SEGUE	TOTALE
		2	2

SIGLA/ITEM	FOGLIO/SHEET	FUNZIONE	FUNCTION
ER	1	ELETTRODO RIVELAZIONE FIAMMA	FLAME DETECTION ELECTRODE
EV1	1	ELETTROVALVOLA GAS LATO RETE (O GRUPPO VALVOLE)	GAS ELECTRO-VALVE UPSTREAM (OR VALVES GROUP)
EV2	1	ELETTROVALVOLA GAS LATO BRUCIATORE (O GRUPPO VALVOLE)	GAS ELECTRO-VALVE DOWNSTREAM (OR VALVES GROUP)
FU1.2	1	FUSIBILE DI LINEA	LINE FUSE
FU1.3	1	FUSIBILE AUSILIARIO	AUXILIARY FUSE
IG	1	INTERRUTTORE GENERALE	MAIN DISCONNECTOR
IL	1	INTERRUTTORE LINEA BRUCIATORE	BURNER LINE SWITCH
LB	1	LAMPADA SEGNALAZIONE BLOCCO BRUCIATORE	INDICATOR LIGHT FOR BURNER LOCK-OUT
LF	1	LAMPADA SEGNALAZIONE FUNZIONAMENTO BRUCIATORE	INDICATOR LIGHT BURNER OPERATION
MV	1	MOTORE VENTILATORE	FAN MOTOR
PA	1	PRESSOSTATO ARIA COMBURENTE	COMBUSTION AIR PRESSURE SWITCH
PGMIN	1	PRESSOSTATO GAS DI MINIMA PRESSIONE	MINIMUM GAS PRESSURE SWITCH
SIEMENS LGB../LMG../LME..	1	APPARECCHIATURA CONTROLLO FIAMMA	FLAME MONITOR DEVICE
ST	1	SERIE TERMOSTATI/PRESSOSTATI	SERIES OF THERMOSTATS OR PRESSURE SWITCHES
TA	1	TRASFORMATORE DI ACCENSIONE	IGNITION TRANSFORMER
TS	1	TERMOSTATO/PRESSOSTATO DI SICUREZZA	SAFETY THERMOSTAT OR PRESSURE SWITCH
VPS504	1	CONTROLLO DI TENUTA VALVOLE GAS (OPTIONAL)	GAS LEAKAGE MONITOR DEVICE (OPTIONAL)

Data	21/07/2006	PREC.	FOGLIO
Revisione	00	1	2
Dis. N.	01 - 530	SEGUE	TOTALE
		/	2

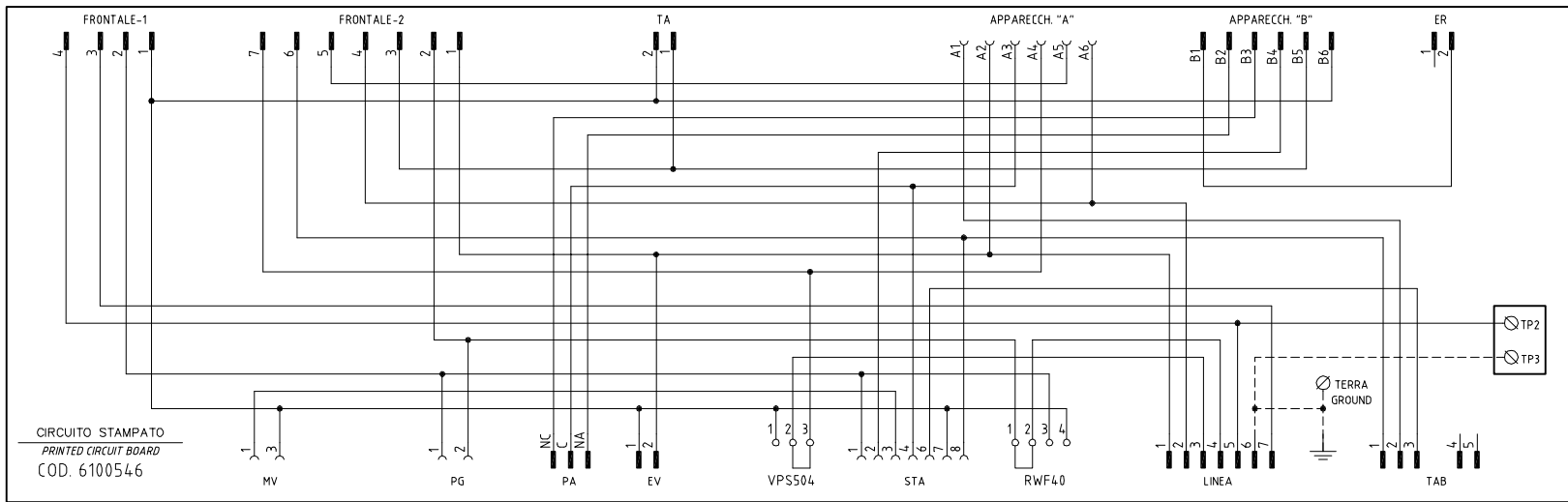
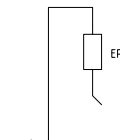
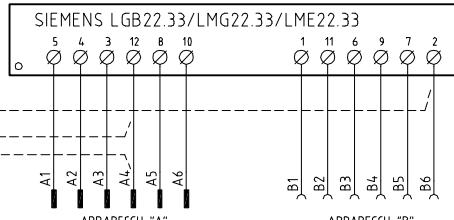
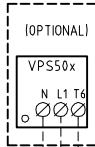
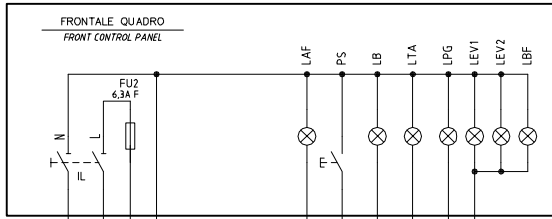

CIRCUITO STAMPATO
PRINTED CIRCUIT BOARD
COD. 6100546

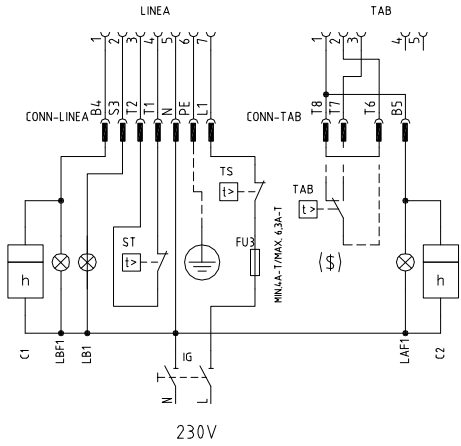
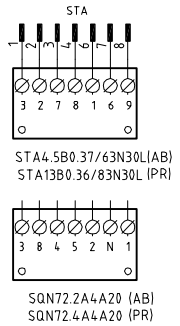
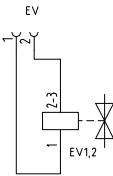
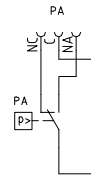
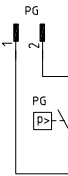
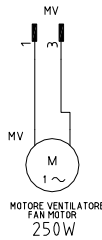

CAMME SERVOCOMANDO SERRANDA ARIA VERSIONE (AB)
CAMS OF AIR DAMPER ACTUATOR VERSION (AB)
STA4.5B0.37/63N30L / STA13B0.36/83N30L

I ALTA FIAMMA HIGH FLAME
II SOSTA STAND-BY
IV BASSA FIAMMA LOW FLAME
III (ARANCIO) NON USATA NOT USED

CAMME SERVOCOMANDO SERRANDA ARIA VERSIONE (PR)
CAMS OF AIR DAMPER ACTUATOR VERSION (PR)
SQN72.xA4A20

I (ROSSO) ALTA FIAMMA HIGH FLAME
II (VERDE) SOSTA STAND-BY
III (BLAU) SOSTA STAND-BY
III (ARANCIO) BASSA FIAMMA LOW FLAME
IV (NERO) NON USATA NOT USED

(xxx) SOLO CON ALIMENTAZIONE ELETTRICA SENZA NEUTRO
WITH ELECTRIC SUPPLY WITHOUT NEUTRAL VERSION ONLY

(\$) SE USATO "TAB", TOGLIERE IL PONTE TRA I MORSETTI T6-T8
IF USED "TAB", REMOVE THE BRIDGE BETWEEN TERMINALS T6-T8

Data	21/07/2006	PREC.	FOGLIO
Revisione	01	/	1
Dis. N.	18 - 103	SEQUE	TOTALE
		2	2

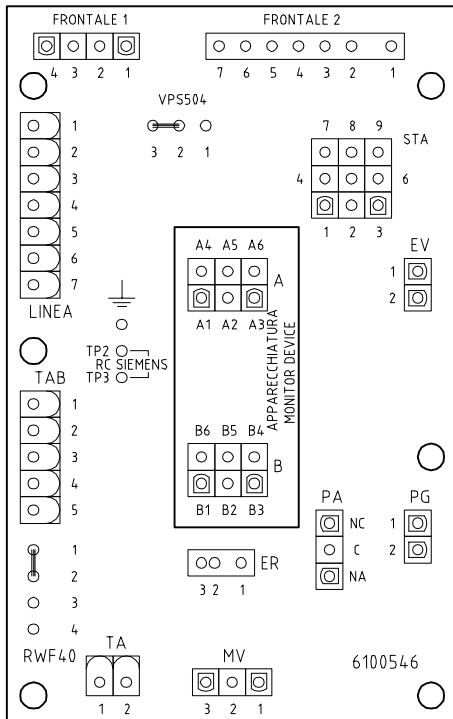

SIGLA/ITEM	FUNZIONE	FUNCTION
C1	CONTAORE BASSA FIAMMA	LOW FLAME TIME COUNTER
C2	CONTAORE ALTA FIAMMA	HIGH FLAME TIME COUNTER
ER	ELETTRODO RILEVAZIONE FIAMMA	FLAME DETECTION ELECTRODE
EV1,2	ELETTROVALVOLE GAS (O GRUPPO VALVOLE)	GAS ELECTRO-VALVES (OR VALVES GROUP)
FU2	FUSIBILE DI LINEA	LINE FUSE
FU3	FUSIBILE LINEA BRUCIATORE	BURNER LINE FUSE
IG	INTERRUTTORE LINEA BRUCIATORE	BURNER LINE SWITCH
IL	INTERRUTTORE LINEA AUSILIARI	AUXILIARY LINE SWITCH
LAF	LAMPADA SEGNALAZIONE ALTA FIAMMA BRUCIATORE	BURNER IN HIGH FLAME INDICATOR LIGHT
LAF1	LAMPADA SEGNALAZIONE ALTA FIAMMA BRUCIATORE	BURNER IN HIGH FLAME INDICATOR LIGHT
LB	LAMPADA SEGNALAZIONE BLOCCO BRUCIATORE	INDICATOR LIGHT FOR BURNER LOCK-OUT
LB1	LAMPADA SEGNALAZIONE BLOCCO BRUCIATORE	INDICATOR LIGHT FOR BURNER LOCK-OUT
LBF	LAMPADA SEGNALAZIONE BASSA FIAMMA BRUCIATORE	BURNER IN LOW FLAME INDICATOR LIGHT
LBF1	LAMPADA SEGNALAZIONE BASSA FIAMMA BRUCIATORE	BURNER IN LOW FLAME INDICATOR LIGHT
LEV1	LAMPADA SEGNALAZIONE APERTURA [EV1]	INDICATOR LIGHT FOR OPENING OF ELECTRO-VALVE [EV1]
LEV2	LAMPADA SEGNALAZIONE APERTURA [EV2]	INDICATOR LIGHT FOR OPENING OF ELECTRO-VALVE [EV2]
LPG	LAMPADA SEGNALAZIONE PRESENZA GAS IN RETE	INDICATOR LIGHT FOR PRESENCE OF GAS IN THE NETWORK
LTA	LAMPADA SEGNALAZIONE TRASFORMATORE DI ACCENSIONE	IGNITION TRANSFORMER INDICATOR LIGHT
MV	MOTORE VENTILATORE	FAN MOTOR
PA	PRESSOSTATO ARIA	AIR PRESSURE SWITCH
PG	PRESSOSTATO GAS DI MINIMA PRESSIONE	MINIMUM GAS PRESSURE SWITCH
PS	PULSANTE SBLOCCO FIAMMA	LOCK-OUT RESET BUTTON
RC	CIRCUITO RC	RC CIRCUIT
SIEMENS LGB22.33/LMG22.33/LME22.33	APPARECCHIATURA CONTROLLO FIAMMA	CONTROL BOX
SQN72.2A4A20	SERVOCOMANDO SERRANDA ARIA VERSIONE [AB]	AIR DAMPER ACTUATOR VERSION [AB]
SQN72.4A4A20	SERVOCOMANDO SERRANDA ARIA VERSIONE [PR]	AIR DAMPER ACTUATOR VERSION [PR]
ST	SERIE TERMOSTATI/PRESSOSTATI	SERIES OF THERMOSTATS OR PRESSURE SWITCHES
STA4.5B0.37/63N30L	SERVOCOMANDO SERRANDA ARIA VERSIONE [AB]	AIR DAMPER ACTUATOR VERSION [AB]
STA13B0.36/83N30L	SERVOCOMANDO SERRANDA ARIA VERSIONE [PR]	AIR DAMPER ACTUATOR VERSION [PR]
TA	TRASFORMATORE DI ACCENSIONE	IGNITION TRANSFORMER
TAB	TERMOSTATO/PRESSOSTATO ALTA-BASSA FIAMMA	HIGH-LOW THERMOSTAT/PRESSURE SWITCHES
TS	TERMOSTATO/PRESSOSTATO DI SICUREZZA	SAFETY THERMOSTAT OR PRESSURE SWITCH
VPS50x	CONTROLLO DI TENUTA VALVOLE GAS (OPTIONAL)	GAS PROVING SYSTEM (OPTIONAL)

Data	21/07/2006	PREC.	FOGLIO
Revisione	01	1	2
Dis. N.	18 - 103	SEQUE	TOTALE
		/	2

VERSIONE MONOSTADIO "TN" "TN" SINGLE-STAGE VERSION

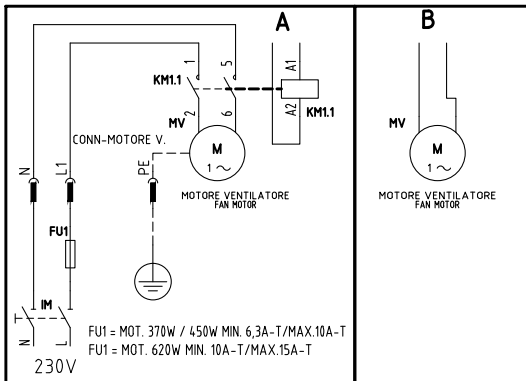
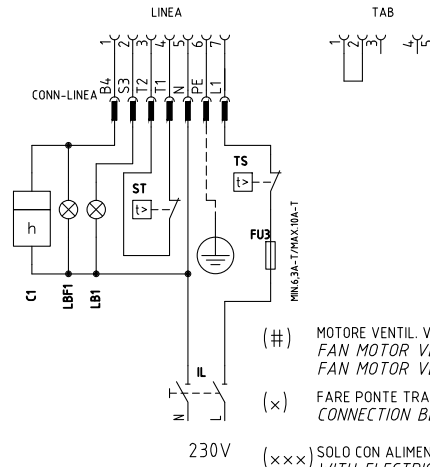
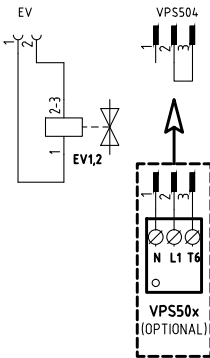
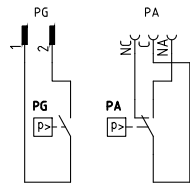
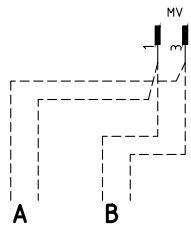
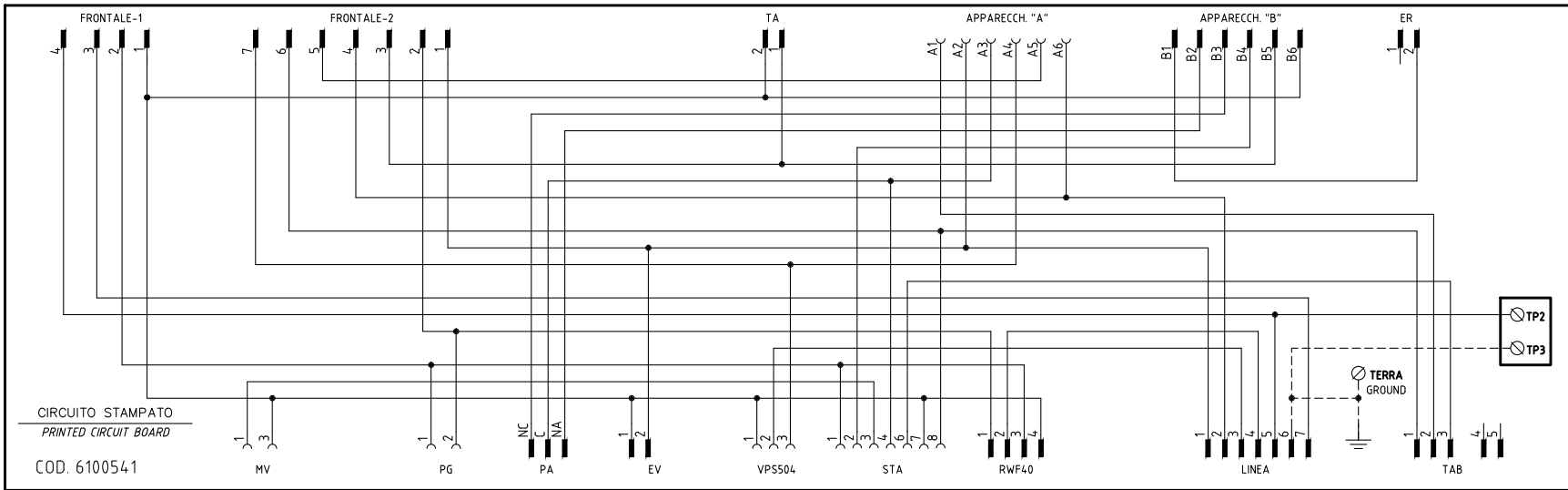
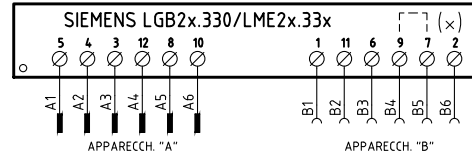
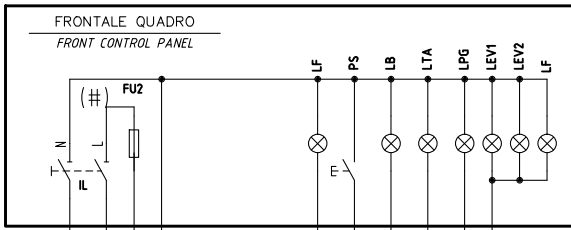

- (#) MOTORE VENTIL. VERSIONE [A], FU2 = 6,3A F; MOTORE VENTIL. VERSIONE [B], FU2 = 10A F
FAN MOTOR VERSION [A], FU2 = 6,3 A F;
FAN MOTOR VERSION [B], FU2 = 10 A F
- (x) FARE PONTE TRA I MORSETTI 7 E 9 SOLO CON LGB21.330
CONNECTION BETWEEN TERMINALS 7 AND 9 WITH LGB21.330 ONLY
- (x x x) SOLO CON ALIMENTAZIONE ELETTRICA SENZA NEUTRO
WITH ELECTRIC SUPPLY WITHOUT NEUTRAL VERSION ONLY

Data	19/10/2010	PREC.	FOGLIO
Revisione	05	/	1
Dis. N.	18 - 0163	SEGUE	TOTALE
		2	5

VERSIONE ALTA-BASSA FIAMMA "AB" / PROGRESSIVO "PR"
 "AB" HIGH-LOW / "PR" PROGRESSIVE VERSION

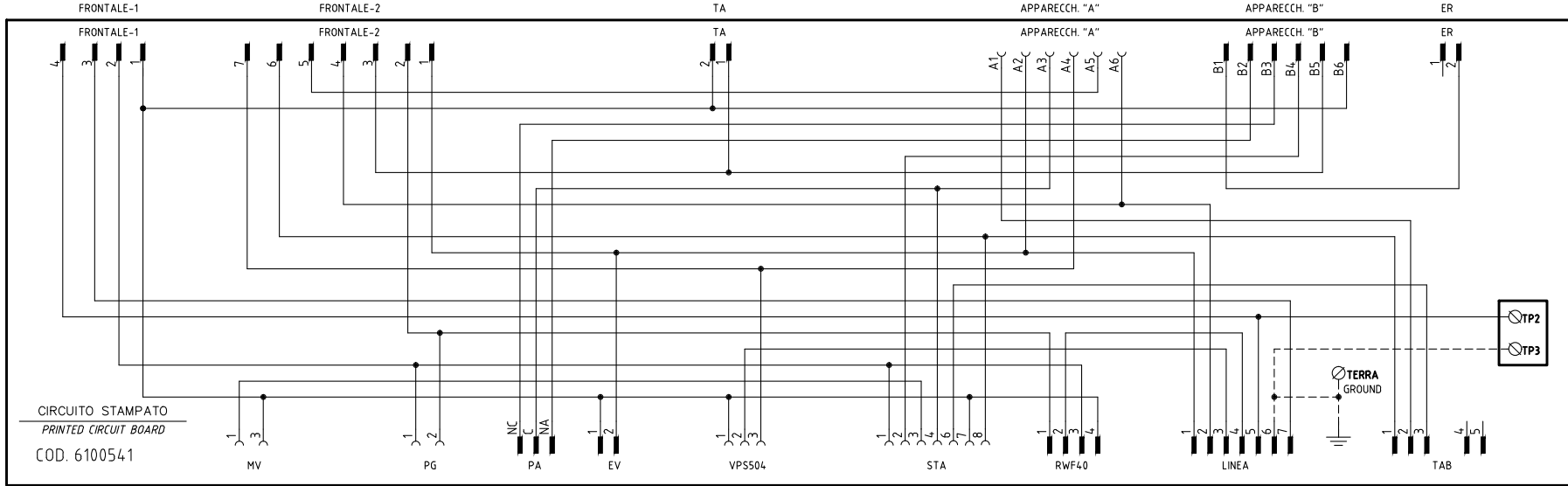
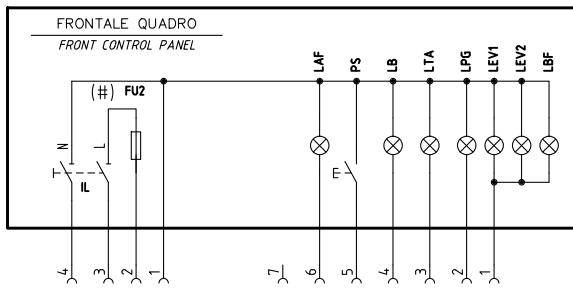

SERVOCOMANDO SERRANDA ARIA
 AIR DAMPER ACTUATOR
 STA13B0.36/83N30L

I ALTA FIAMMA
 HIGH FLAME
 SOSTA
 STAND-BY
 II BASSA FIAMMA
 LOW FLAME
 III NON USATA
 NOT USED

SERVOCOMANDO SERRANDA ARIA
 AIR DAMPER ACTUATOR
 SIEMENS SQNT2.xA4.A20

I (ROSSO) ALTA FIAMMA
 HIGH FLAME
 II (BLU) SOSTA
 STAND-BY
 III (ARANCIO) BASSA FIAMMA
 LOW FLAME
 IV (NERO) NON USATA
 NOT USED

CIRCUITO STAMPATO
 PRINTED CIRCUIT BOARD
 COD. 6100541

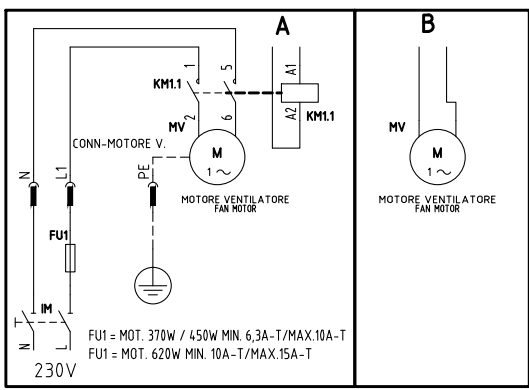
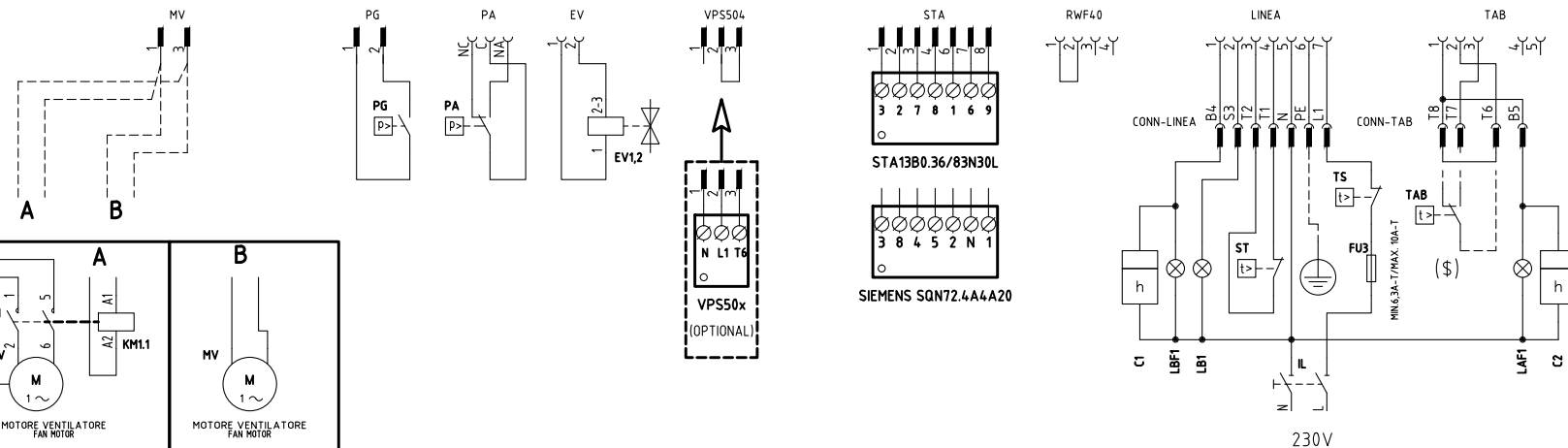

(#) MOTORE VENTIL. VERSIONE [A], FU2 = 6,3A F; MOTORE VENTIL. VERSIONE [B], FU2 = 10A F
 FAN MOTOR VERSION [A], FU2 = 6,3 A F;
 FAN MOTOR VERSION [B], FU2 = 10 A F

(x x x) SOLO CON ALIMENTAZIONE ELETTRICA SENZA NEUTRO
 WITH ELECTRIC SUPPLY WITHOUT NEUTRAL VERSION ONLY

(\$) SE USATO "TAB", TOGLIERE IL PONTE TRA I MORSETTI T6-T8
 IF USED "TAB", REMOVE THE BRIDGE BETWEEN TERMINALS T6-T8

Data	19/10/2010	PREC.	FOGLIO
Revisione	05	1	2
Dis. N.	18 - 0163	SEGUE	TOTALE
		3	5

VERSIONE MODULANTE "MD"
"MD" MODULATING VERSION

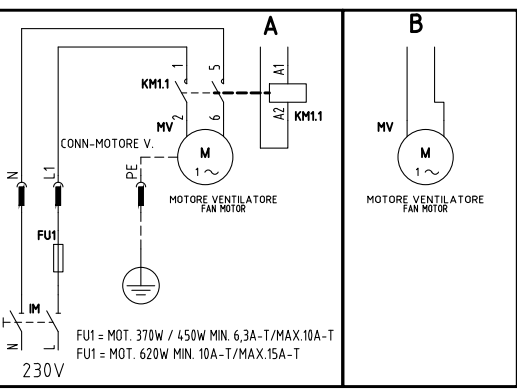
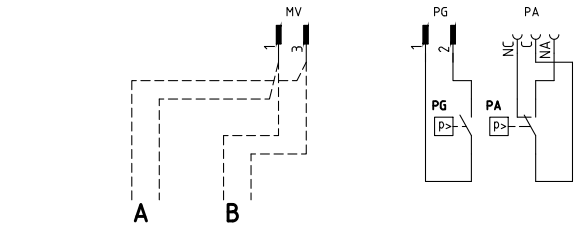
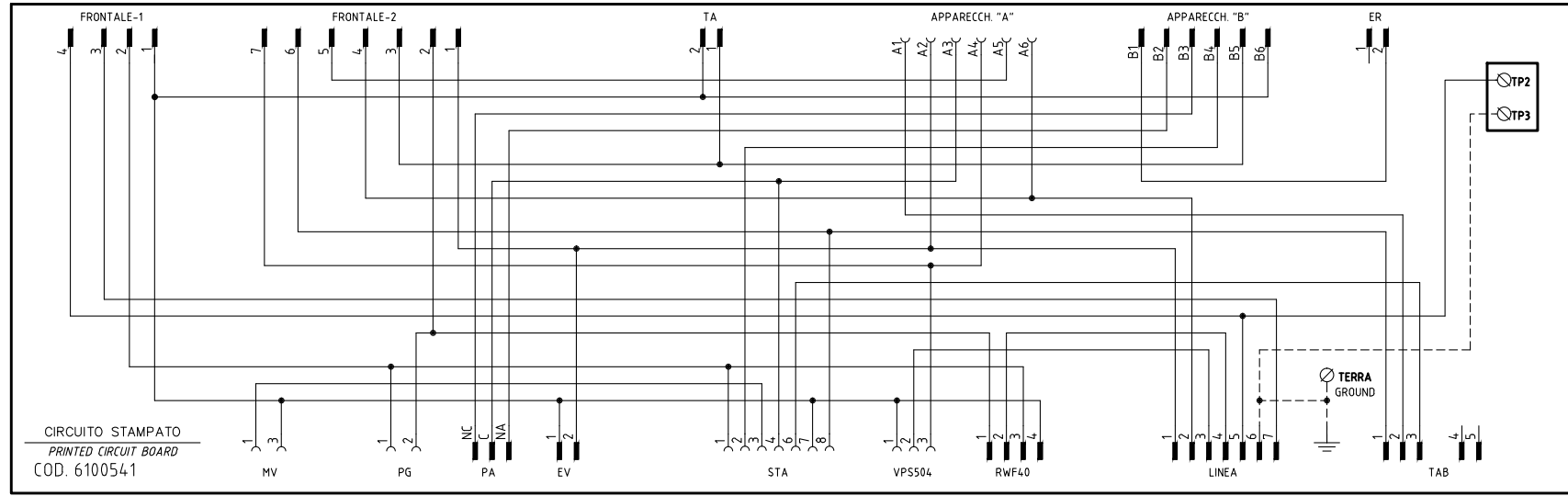
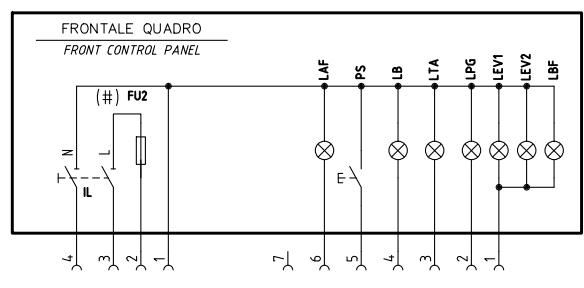

SERVOCOMANDO SERRANDA ARIA
AIR DAMPER ACTUATOR
STA13B0.36/83N30L

I ALTA FIAMMA HIGH FLAME
II SOSTA STAND-BY
III BASSA FIAMMA LOW FLAME
IV NON USATA NOT USED

SERVOCOMANDO SERRANDA ARIA
AIR DAMPER ACTUATOR
SIEMENS SQN72.xA4.A20

I (ROSSO) ALTA FIAMMA HIGH FLAME
II (BLU) SOSTA STAND-BY
III (ARANCIO) BASSA FIAMMA LOW FLAME
IV (NERO) NON USATA NOT USED

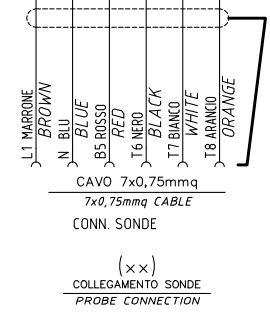
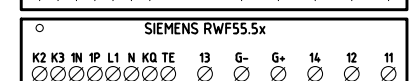
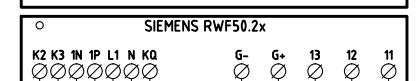
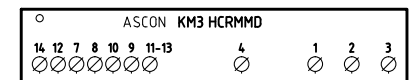
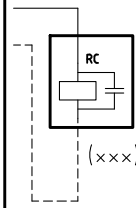
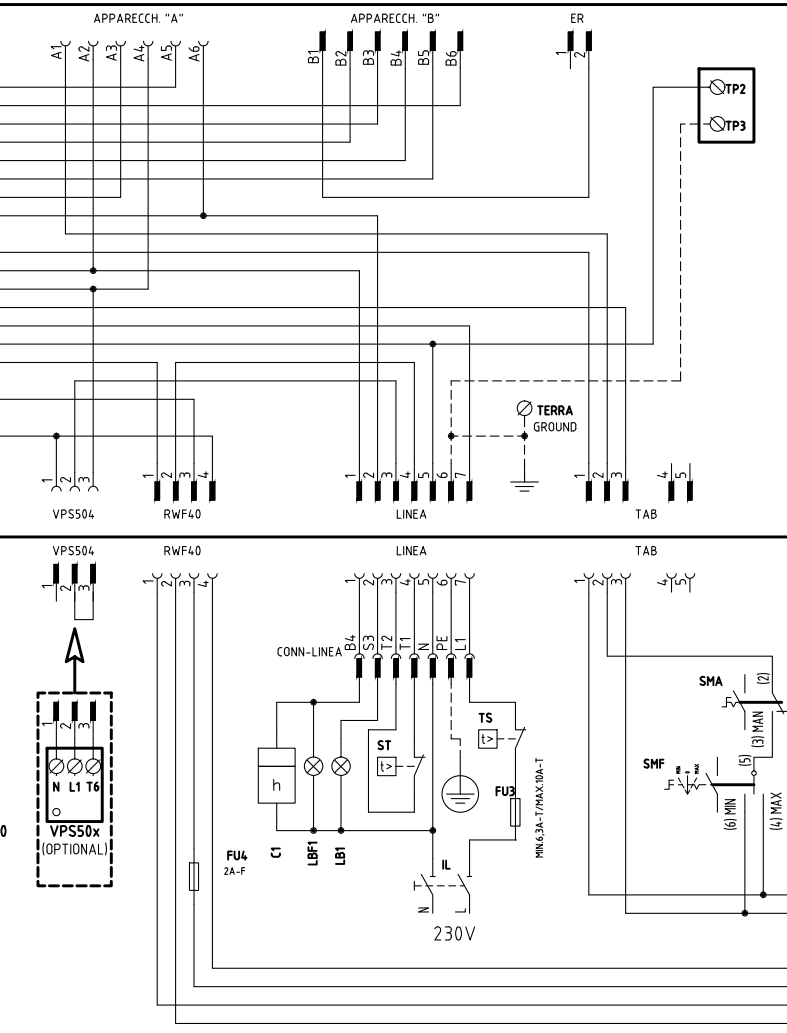
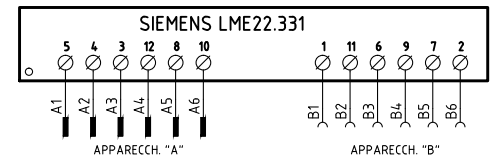

(#) MOTORE VENTIL. VERSIONE [A], FU2 = 6,3A F; MOTORE VENTIL. VERSIONE [B], FU2 = 10A F
FAN MOTOR VERSION [A], FU2= 6,3 A F;
FAN MOTOR VERSION [B], FU2= 10 A F

(x x x) SOLO CON ALIMENTAZIONE ELETTRICA SENZA NEUTRO
WITH ELECTRIC SUPPLY WITHOUT NEUTRAL VERSION ONLY

Data	19/10/2010	PREC.	FOGLIO
Revisione	05	2	3
Dis. N.	18 - 0163	SEGUE	TOTALE
		4	5

Sigla/Item	Funzione	Function
600V RRR0-1-T73	REGOLATORE MODULANTE (ALTERNATIVO)	BURNER MODULATOR (ALTERNATIVE)
C1	CONTAORE BASSA FIAMMA	LOW FLAME TIME COUNTER
C2	CONTAORE ALTA FIAMMA	HIGH FLAME TIME COUNTER
ER	ELETTRODO RILEVAZIONE FIAMMA	FLAME DETECTION ELECTRODE
EV1,2	ELETTROVALVOLE GAS (O GRUPPO VALVOLE)	GAS ELECTRO-VALVES (OR VALVES GROUP)
FU1	FUSIBILE LINEA MOTORE VENTILATORE	FAN MOTOR LINE FUSE
FU2	FUSIBILE DI LINEA	LINE FUSE
FU3	FUSIBILE DI LINEA	LINE FUSE
FU4	FUSIBILE AUSILIARIO	AUXILIARY FUSE
IL	INTERRUTTORE LINEA BRUCIATORE	BURNER LINE SWITCH
IM	INTERRUTTORE LINEA MOTORE VENTILATORE	FAN MOTOR LINE SWITCH
KM1.1	CONTATTORE MOTORE VENTILATORE	FAN MOTOR CONTACTOR
KM3 HCRMMD	REGOLATORE MODULANTE (ALTERNATIVO)	BURNER MODULATOR (ALTERNATIVE)
LAF	LAMPADA SEGNALAZIONE ALTA FIAMMA BRUCIATORE	BURNER IN HIGH FLAME INDICATOR LIGHT
LAF1	LAMPADA SEGNALAZIONE ALTA FIAMMA BRUCIATORE	BURNER IN HIGH FLAME INDICATOR LIGHT
LB	LAMPADA SEGNALAZIONE BLOCCO BRUCIATORE	INDICATOR LIGHT FOR BURNER LOCK-OUT
LB1	LAMPADA SEGNALAZIONE BLOCCO BRUCIATORE	INDICATOR LIGHT FOR BURNER LOCK-OUT
LBF	LAMPADA SEGNALAZIONE BASSA FIAMMA BRUCIATORE	BURNER IN LOW FLAME INDICATOR LIGHT
LBF1	LAMPADA SEGNALAZIONE BASSA FIAMMA BRUCIATORE	BURNER IN LOW FLAME INDICATOR LIGHT
LEV1	LAMPADA SEGNALAZIONE APERTURA [EV1]	INDICATOR LIGHT FOR OPENING OF ELECTRO-VALVE [EV1]
LEV2	LAMPADA SEGNALAZIONE APERTURA [EV2]	INDICATOR LIGHT FOR OPENING OF ELECTRO-VALVE [EV2]
LF	LAMPADA SEGNALAZIONE FUNZIONAMENTO BRUCIATORE	INDICATOR LIGHT BURNER OPERATION
LPG	LAMPADA SEGNALAZIONE PRESENZA GAS IN RETE	INDICATOR LIGHT FOR PRESENCE OF GAS IN THE NETWORK
LTA	LAMPADA SEGNALAZIONE TRASFORMATORE DI ACCENSIONE	IGNITION TRANSFORMER INDICATOR LIGHT
MV	MOTORE VENTILATORE	FAN MOTOR
PA	PRESSOSTATO ARIA	AIR PRESSURE SWITCH
PG	PRESSOSTATO GAS DI MINIMA PRESSIONE	MINIMUM GAS PRESSURE SWITCH
PS	PULSANTE SBLOCCO FIAMMA	FLAME UNLOCK BUTTON
PT100	SONDA DI TEMPERATURA	TEMPERATURE PROBE
RC	CIRCUITO RC	RC CIRCUIT
SD-PRESS	SONDA DI PRESSIONE	PRESSURE PROBE
SD-TEMP.	SONDA DI TEMPERATURA	TEMPERATURE PROBE
SD - 0÷10V	TRASDUTTORE USCITA IN TENSIONE	TRANSDUCER VOLTAGE OUTPUT
SD - 4÷20mA	TRASDUTTORE USCITA IN CORRENTE	TRANSDUCER CURRENT OUTPUT
SIEMENS LGB2x.330/LME2x.33x	APPARECCHIATURA CONTROLLO FIAMMA	CONTROL BOX
SIEMENS LME22.331	APPARECCHIATURA CONTROLLO FIAMMA	CONTROL BOX
SIEMENS RWF50.2x	REGOLATORE MODULANTE	BURNER MODULATOR
SIEMENS RWF55.5x	REGOLATORE MODULANTE (ALTERNATIVO)	BURNER MODULATOR (ALTERNATIVE)
SIEMENS SQN72.4A4A20	SERVOCOMANDO SERRANDA ARIA (ALTERNATIVO)	AIR DAMPER ACTUATOR (ALTERNATIVE)
SMA	SELETTORE MANUALE/AUTOMATICO	MANUAL/AUTOMATIC SWITCH
SMF	SELETTORE MANUALE FUNZIONAMENTO MIN-0-MAX	MIN-0-MAX MANUAL OPERATION SWITCH
ST	SERIE TERMOSTATI/PRESSOSTATI	SERIES OF THERMOSTATS OR PRESSURE SWITCHES
STA13B0.36/83N30L	SERVOCOMANDO SERRANDA ARIA	AIR DAMPER ACTUATOR
TA	TRASFORMATORE DI ACCENSIONE	IGNITION TRANSFORMER
TAB	TERMOSTATO/PRESSOSTATO ALTA-BASSA FIAMMA	HIGH-LOW THERMOSTAT/PRESSURE SWITCHES
TC	TERMOCOPPIA	THERMOCOUPLE
TS	TERMOSTATO/PRESSOSTATO DI SICUREZZA	SAFETY THERMOSTAT OR PRESSURE SWITCH
VPS50x	CONTROLLO DI TENUTA VALVOLE GAS (OPTIONAL)	GAS PROVING SYSTEM (OPTIONAL)

Data	19/10/2010	PREC.	FOGLIO
Revisione	05	4	5
Dis. N.	18 - 0163	SEGUE	TOTALE
		/	5

VERSIONE MONOSTADIO "TN" "TN" SINGLE-STAGE VERSION

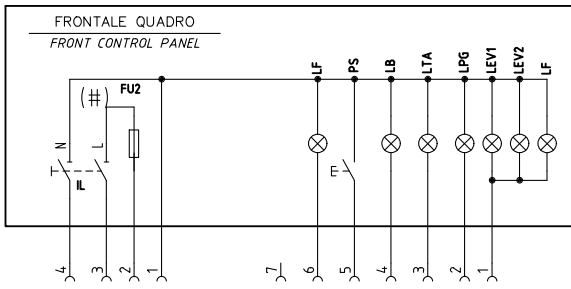

FRONTALE-1

FRONTALE-2

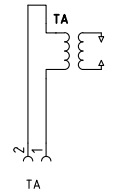

TA

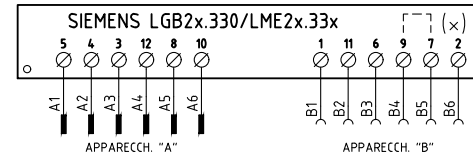

APPARECCH. "A"

APPARECCH. "B"

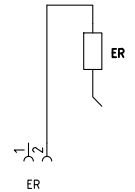

ER

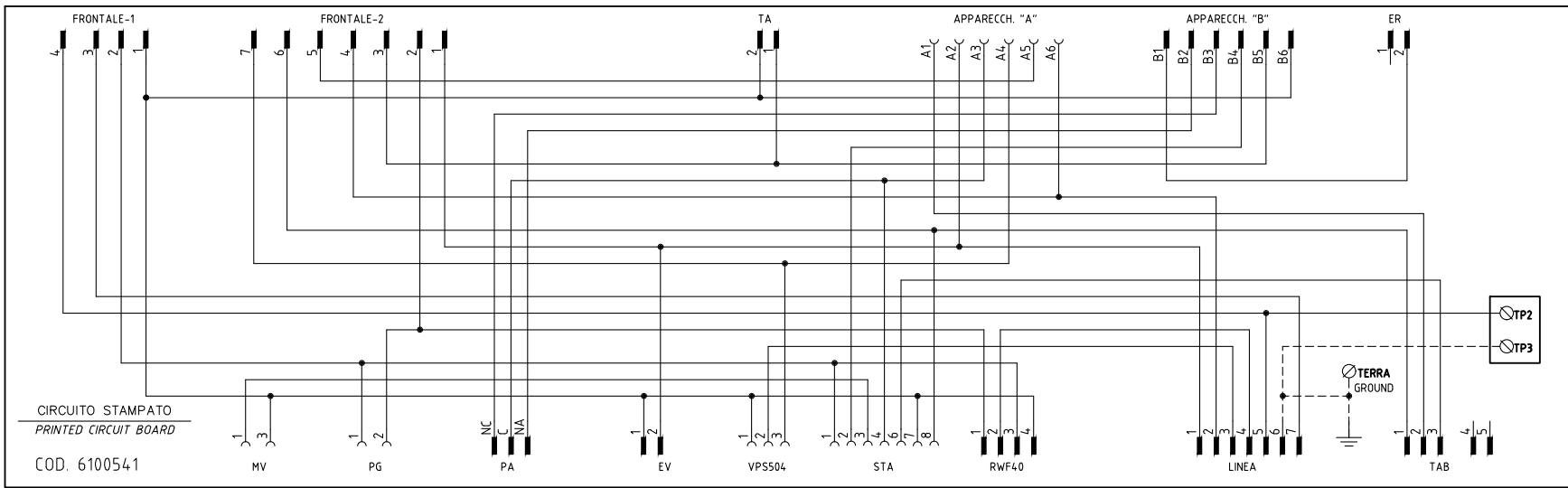

CIRCUITO STAMPATO
PRINTED CIRCUIT BOARD

COD. 6100541

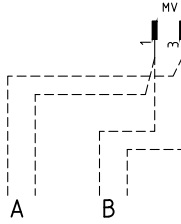

A

B

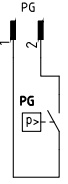

PG

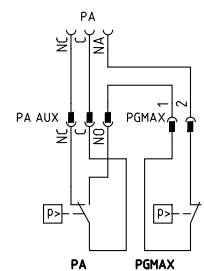

PA

PGMAX

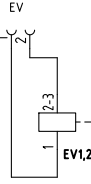

EV



VPS504



STA



RWF40

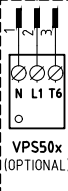

VPS50x
(OPTIONAL)

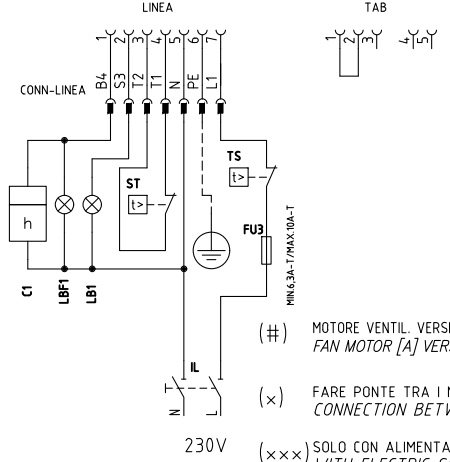

CONN-LINEA

LINEA

TAB

230V

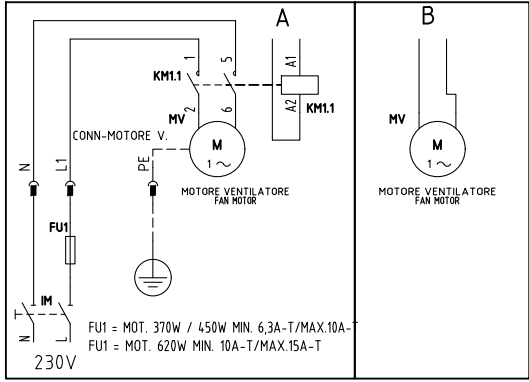

A

B

FU1 = MOT. 370W / 450W MIN. 6,3A-T/MAX.10A-T
FU1 = MOT. 620W MIN. 10A-T/MAX.15A-T

230V

- (#) MOTORE VENTIL. VERSIONE [A], FU2 = 6,3A F; MOTORE VENTIL. VERSIONE [B], FU2 = 10A F
FAN MOTOR [A] VERSION, FU2 = 6,3A F; FAN MOTOR [B] VERSION FU2 = 10A F
- (x) FARE PONTE TRA I MORSETTI 7 E 9 SOLO CON LGB21.330
CONNECTION BETWEEN TERMINALS 7 AND 9 WITH LGB21.330 ONLY
- (xxx) SOLO CON ALIMENTAZIONE ELETTRICA SENZA NEUTRO
WITH ELECTRIC SUPPLY WITHOUT NEUTRAL VERSION ONLY

Data	14/01/2005	PREC.	FOGLIO
Revisione	07	/	1
Dis. N.	18 - 0057	SEGUE	TOTALE
		2	5

VERSIONE ALTA-BASSA FIAMMA "AB" / PROGRESSIVO "PR"
 "AB" HIGH-LOW / "PR" PROGRESSIVE VERSION

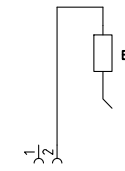
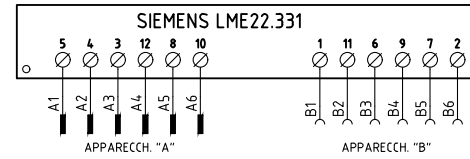
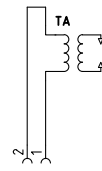
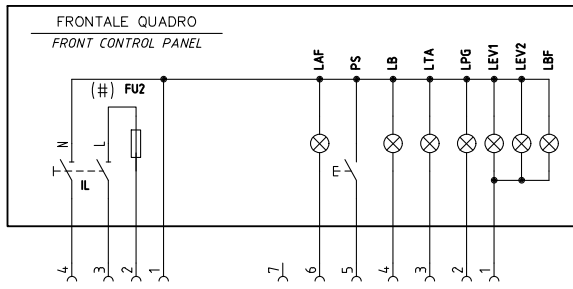

SERVOCOMANDO SERRANDA ARIA
 AIR DAMPER ACTUATOR
 STA13B0.36/83N30L

I ALTA FIAMMA
 HIGH FLAME
 II SOSTA
 STAND-BY
 III BASSA FIAMMA
 LOW FLAME
 IV NON USATA
 NOT USED

SERVOCOMANDO SERRANDA ARIA
 AIR DAMPER ACTUATOR
 SIEMENS SQNT2.xA4A20

I (ROSSO) ALTA FIAMMA
 HIGH FLAME
 II (VERDE) SOSTA
 STAND-BY
 III (BLU) BASSA FIAMMA
 LOW FLAME
 IV (ARANCIO) BASSA FIAMMA
 LOW FLAME
 V (NERO) NON USATA
 NOT USED

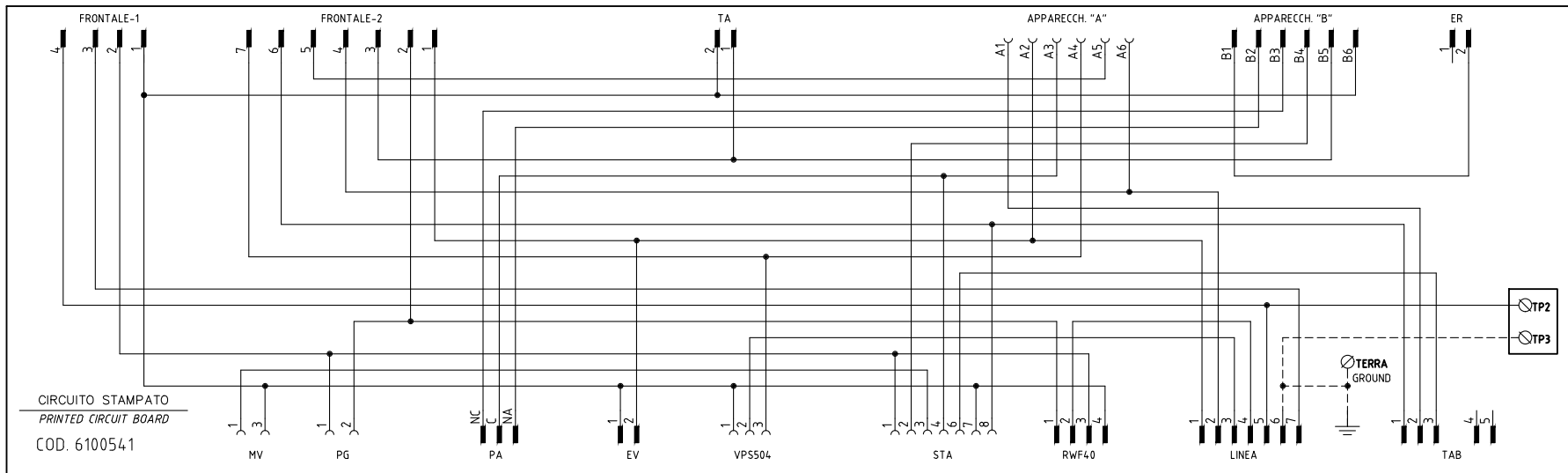

COD. 6100541

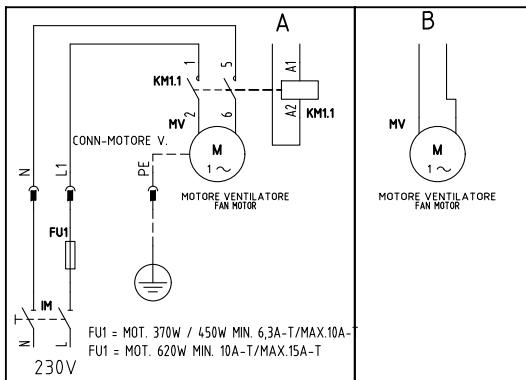
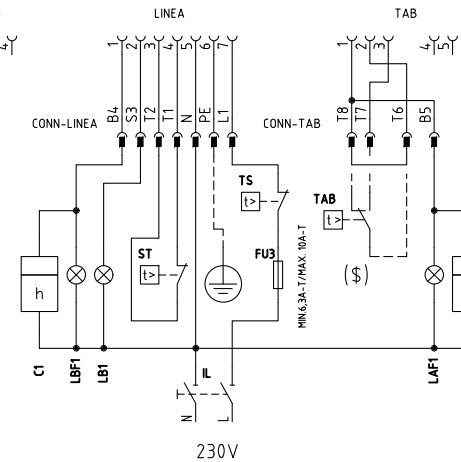
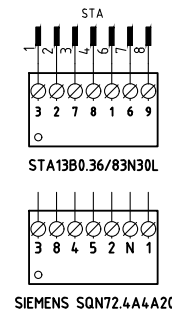
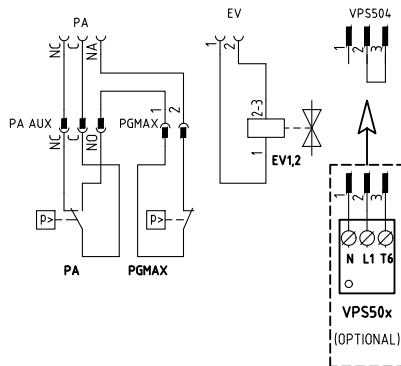
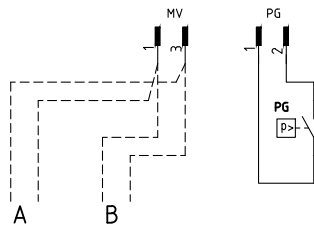

(#) MOTORE VENTIL. VERSIONE [A], FU2 = 6,3A F; MOTORE VENTIL. VERSIONE [B], FU2 = 10A F
 FAN MOTOR [A] VERSION, FU2 = 6,3A F; FAN MOTOR [B] VERSION FU2 = 10A F

(x x x) SOLO CON ALIMENTAZIONE ELETTRICA SENZA NEUTRO
 WITH ELECTRIC SUPPLY WITHOUT NEUTRAL VERSION ONLY

(\$) SE USATO "TAB", TOGLIERE IL PONTE TRA I MORSETTI T6-T8
 IF USED "TAB", REMOVE THE BRIDGE BETWEEN TERMINALS T6-T8

Data	14/01/2005	PREC.	FOGLIO
Revisione	07	1	2
Dis. N.	18 - 0057	SEGUE	TOTALE
		3	5

VERSIONE MODULANTE "MD"
"MD" MODULATING VERSION

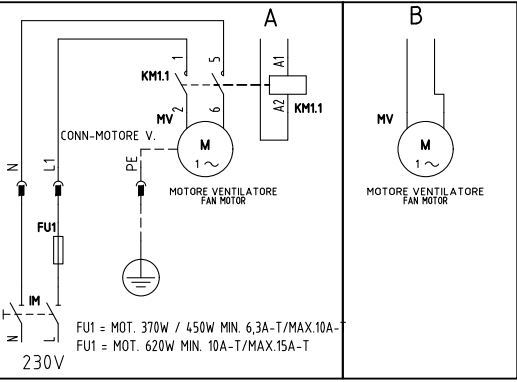
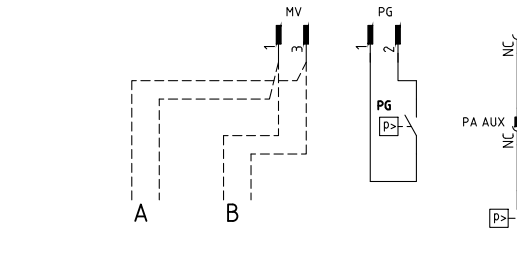
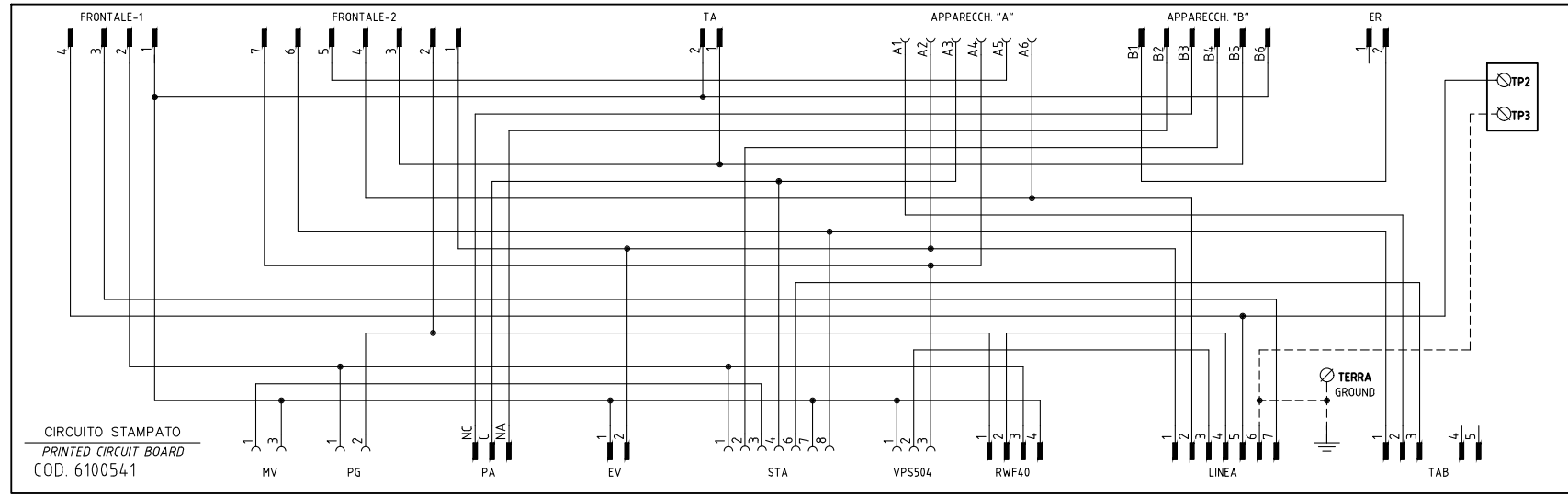
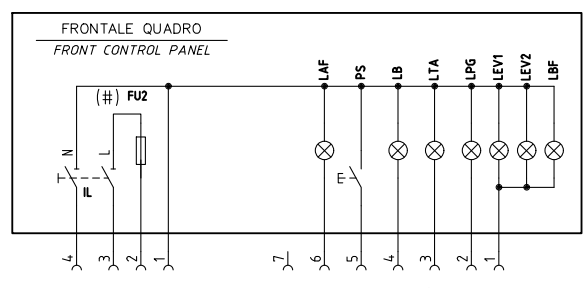

SERVOCOMANDO SERRANDA ARIA
AIR DAMPER ACTUATOR
STA13B0.36/83N30L

I ALTA FIAMMA HIGH FLAME
II SOSTA STAND-BY
III BASSA FIAMMA LOW FLAME
IV (NERO) NON USATA NOT USED

SERVOCOMANDO SERRANDA ARIA
AIR DAMPER ACTUATOR
SIEMENS SQN72.xA4.A20

I (ROSSO) ALTA FIAMMA HIGH FLAME
II (BLU) SOSTA STAND-BY
III (ARANCIO) BASSA FIAMMA LOW FLAME
IV (NERO) NON USATA NOT USED

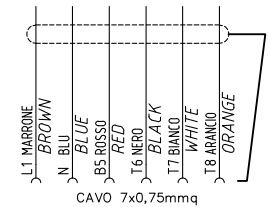
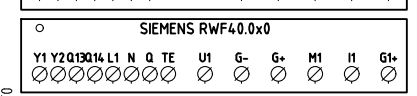
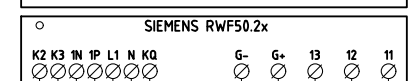
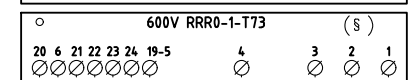
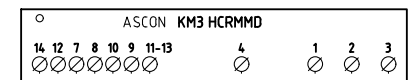
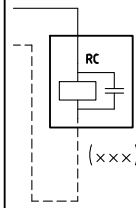
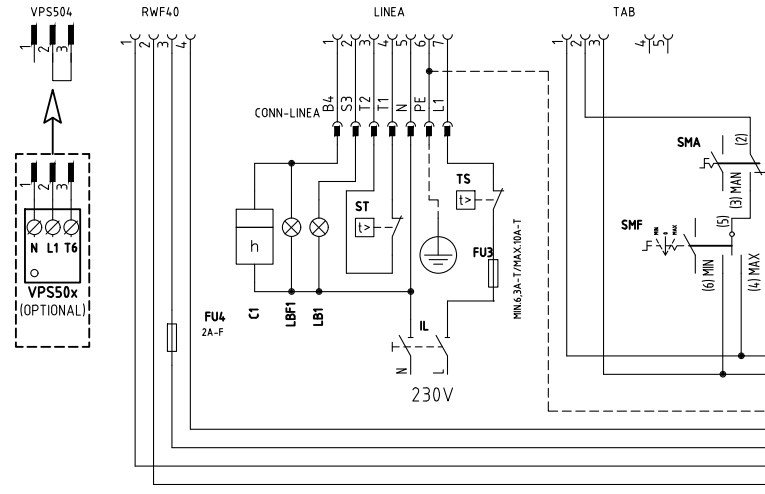
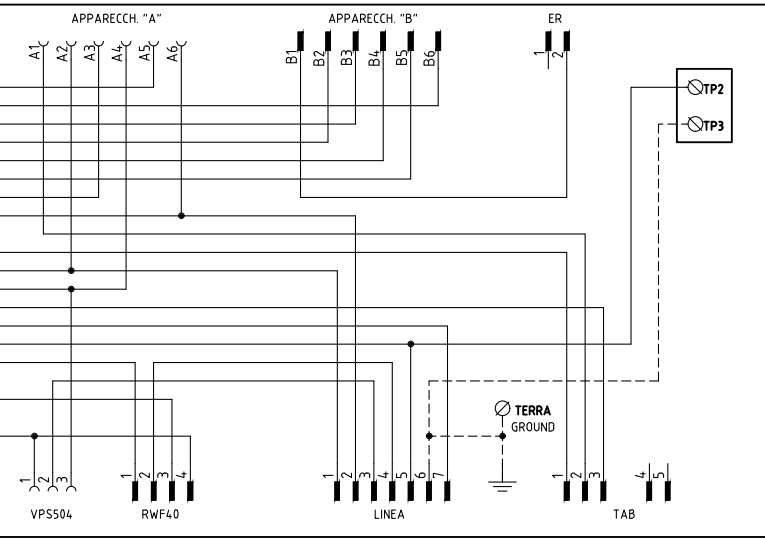
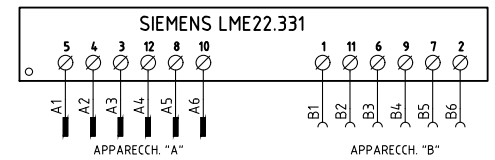

(#) MOTORE VENTIL. VERSIONE [A], FU2 = 6,3A F; MOTORE VENTIL. VERSIONE [B], FU2 = 10A F
FAN MOTOR [A] VERSION, FU2 = 6,3A F; FAN MOTOR [B] VERSION FU2 = 10A F

(x x x) SOLO CON ALIMENTAZIONE ELETTRICA SENZA NEUTRO
WITH ELECTRIC SUPPLY WITHOUT NEUTRAL VERSION ONLY

Data	14/01/2005	PREC.	FOGLIO
Revisione	07	2	3
Dis. N.	18 - 0057	SEGUE	TOTALE
		4	5

(xx)
 ATTENZIONE COLLEGAMENTO SONDE CON CONNETTORE 7 POLI
 WARNING PROBE CONNECTION WITH 7 PINS CONNECTOR

KM3 HCRMMD

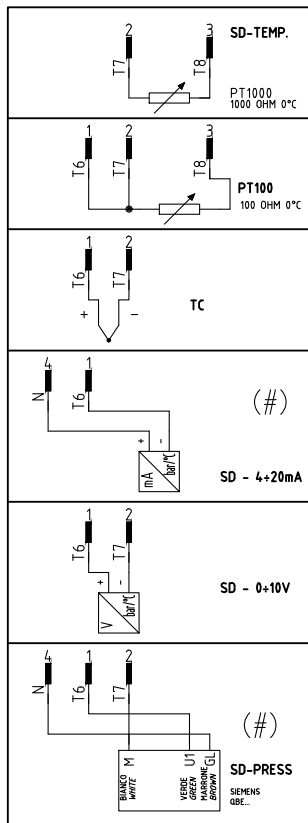

600V RRR0-1-T73

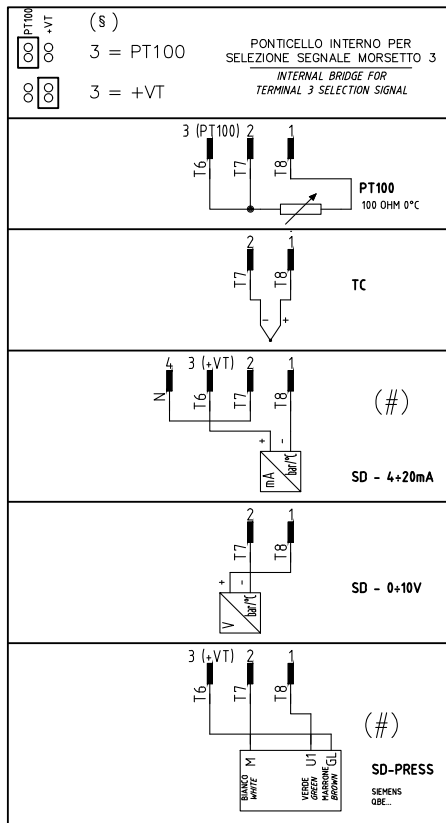

RWF55.5x

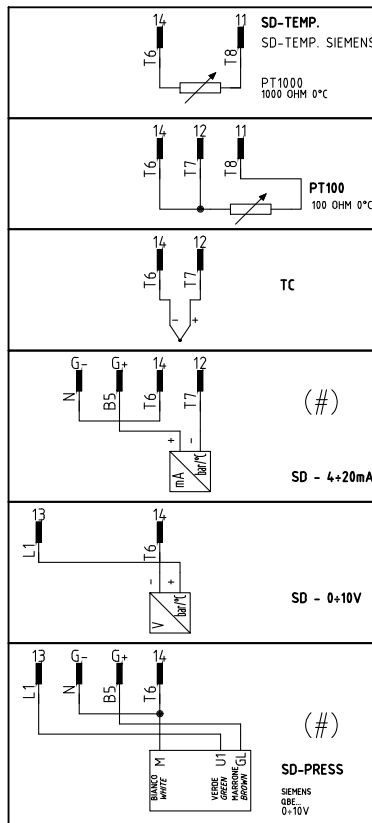

RWF50.2x

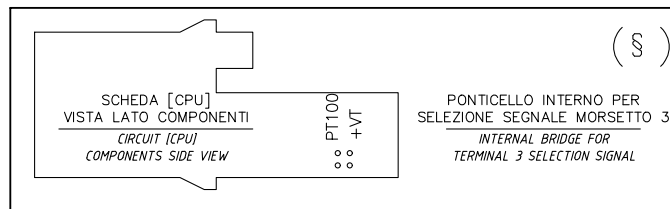
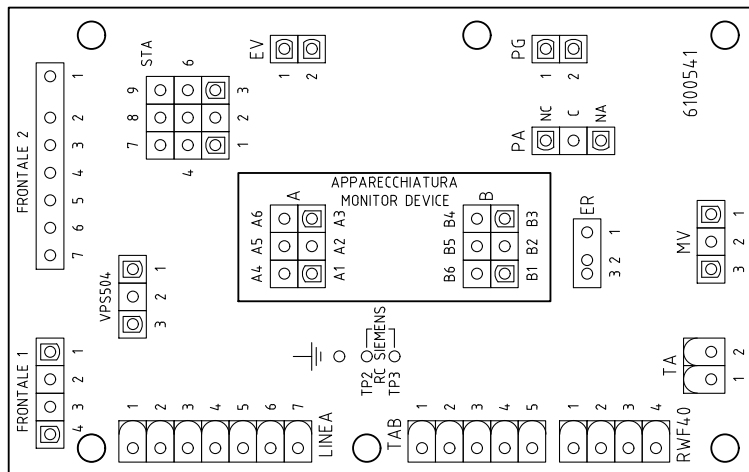
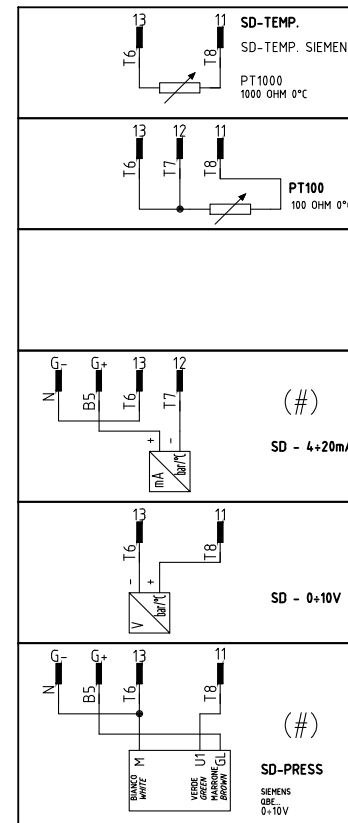

Data	14/01/2005	PREC.	FOGLIO
Revisione	07	3	4
Dis. N.	18 - 0057	SEGUE	TOTALE
		5	5

Sigla/Item	Funzione	Function
PGMAX	PRESSOSTATO GAS DI MASSIMA PRESSIONE	MAXIMUM PRESSURE GAS SWITCH
600V RRR0-1-T73	REGOLATORE MODULANTE (ALTERNATIVO)	BURNER MODULATOR (ALTERNATIVE)
C1	CONTAORE BASSA FIAMMA	LOW FLAME TIME COUNTER
C2	CONTAORE ALTA FIAMMA	HIGH FLAME TIME COUNTER
ER	ELETTRODO RILEVAZIONE FIAMMA	FLAME DETECTION ELECTRODE
EV1,2	ELETTROVALVOLE GAS (O GRUPPO VALVOLE)	GAS ELECTRO-VALVES (OR VALVES GROUP)
FU1	FUSIBILE LINEA MOTORE VENTILATORE	FAN MOTOR LINE FUSE
FU2	FUSIBILE DI LINEA	LINE FUSE
FU3	FUSIBILE DI LINEA	LINE FUSE
FU4	FUSIBILE AUSILIARIO	AUXILIARY FUSE
IL	INTERRUTTORE LINEA BRUCIATORE	BURNER LINE SWITCH
IM	INTERRUTTORE LINEA MOTORE VENTILATORE	FAN MOTOR LINE SWITCH
KM1.1	CONTATTORE MOTORE VENTILATORE	FAN MOTOR CONTACTOR
KM3 HCRMD	REGOLATORE MODULANTE (ALTERNATIVO)	BURNER MODULATOR (ALTERNATIVE)
LAF	LAMPADA SEGNALAZIONE ALTA FIAMMA BRUCIATORE	BURNER IN HIGH FLAME INDICATOR LIGHT
LAF1	LAMPADA SEGNALAZIONE ALTA FIAMMA BRUCIATORE	BURNER IN HIGH FLAME INDICATOR LIGHT
LB	LAMPADA SEGNALAZIONE BLOCCO BRUCIATORE	INDICATOR LIGHT FOR BURNER LOCK-OUT
LB1	LAMPADA SEGNALAZIONE BLOCCO BRUCIATORE	INDICATOR LIGHT FOR BURNER LOCK-OUT
LBF	LAMPADA SEGNALAZIONE BASSA FIAMMA BRUCIATORE	BURNER IN LOW FLAME INDICATOR LIGHT
LBF1	LAMPADA SEGNALAZIONE BASSA FIAMMA BRUCIATORE	BURNER IN LOW FLAME INDICATOR LIGHT
LEV1	LAMPADA SEGNALAZIONE APERTURA [EV1]	INDICATOR LIGHT FOR OPENING OF ELECTRO-VALVE [EV1]
LEV2	LAMPADA SEGNALAZIONE APERTURA [EV2]	INDICATOR LIGHT FOR OPENING OF ELECTRO-VALVE [EV2]
LF	LAMPADA SEGNALAZIONE FUNZIONAMENTO BRUCIATORE	INDICATOR LIGHT BURNER OPERATION
LPG	LAMPADA SEGNALAZIONE PRESENZA GAS IN RETE	INDICATOR LIGHT FOR PRESENCE OF GAS IN THE NETWORK
LTA	LAMPADA SEGNALAZIONE TRASFORMATORE DI ACCENSIONE	IGNITION TRANSFORMER INDICATOR LIGHT
MV	MOTORE VENTILATORE	FAN MOTOR
PA	PRESSOSTATO ARIA	AIR PRESSURE SWITCH
PG	PRESSOSTATO GAS DI MINIMA PRESSIONE	MINIMUM GAS PRESSURE SWITCH
PS	PULSANTE SBLOCCO FIAMMA	FLAME UNLOCK BUTTON
RC	CIRCUITO RC	RC CIRCUIT
SIEMENS LGB2x.330/LME2x.33x	APPARECCHIATURA CONTROLLO FIAMMA	CONTROL BOX
SIEMENS LME22.331	APPARECCHIATURA CONTROLLO FIAMMA	CONTROL BOX
SIEMENS RWF40.0x0	REGOLATORE MODULANTE	BURNER MODULATOR
SIEMENS RWF50.2x	REGOLATORE MODULANTE (ALTERNATIVO)	BURNER MODULATOR (ALTERNATIVE)
SIEMENS SQN72.4A4A20	SERVOCOMANDO SERRANDA ARIA (ALTERNATIVO)	AIR DAMPER ACTUATOR (ALTERNATIVE)
SMA	SELETTORE MANUALE/AUTOMATICO	MANUAL/AUTOMATIC SWITCH
SMF	SELETTORE MANUALE FUNZIONAMENTO MIN-0-MAX	MIN-0-MAX MANUAL OPERATION SWITCH
ST	SERIE TERMOSTATI/PRESSOSTATI	SERIES OF THERMOSTATS OR PRESSURE SWITCHES
STA13B0.36/83N30L	SERVOCOMANDO SERRANDA ARIA	AIR DAMPER ACTUATOR
TA	TRASFORMATORE DI ACCENSIONE	IGNITION TRANSFORMER
TAB	TERMOSTATO/PRESSOSTATO ALTA-BASSA FIAMMA	HIGH-LOW THERMOSTAT/PRESSURE SWITCHES
TS	TERMOSTATO/PRESSOSTATO DI SICUREZZA	SAFETY THERMOSTAT OR PRESSURE SWITCH
VPS50x	CONTROLLO DI TENUTA VALVOLE GAS (OPTIONAL)	GAS PROVING SYSTEM (OPTIONAL)

Data	14/01/2005	PREC.	FOGLIO
Revisione	07	4	5
Dis. N.	18 - 0057	SEGUE	TOTALE
		/	5

VERSIONE ALTA-BASSA FIAMMA / PROGRESSIVO CON RELE' "KAB" DI SEZIONAMENTO
 HIGH-LOW / PROGRESSIVE VERSION WITH "KAB" SECTIONING RELAY
 ИСПОЛНЕНИЕ ДВУХСТУПЕНЧАТОЕ / ПРОГРЕССИВНОЕ С РАЗДЕЛИТЕЛЬНЫМ РЕЛЕ «КАВ»

CONNETTORE [3] POLI
 [3] PINS CONNECTOR
 [3]-ТИ ПОЛЮСНЫЙ СОЕДИНИТЕЛЬНЫЙ РАЗЪЕМ

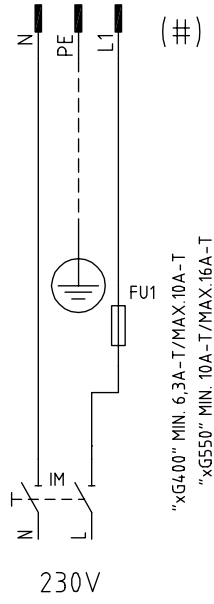

CONNETTORE [7] POLI
 [7] PINS CONNECTOR
 [7]-ТИ ПОЛЮСНЫЙ СОЕДИНИТЕЛЬНЫЙ РАЗЪЕМ

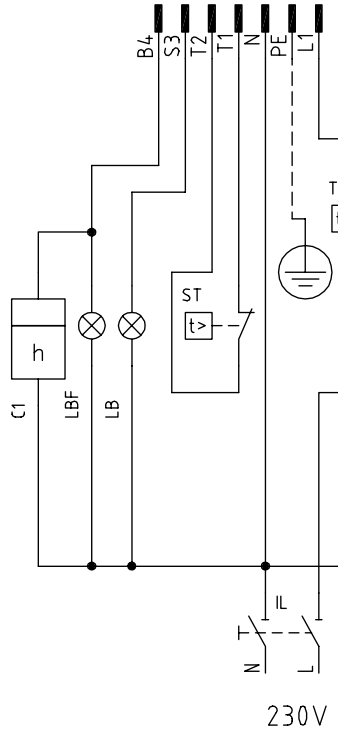

CONNETTORE [4] POLI
 [4] PINS CONNECTOR
 [4]-ТИ ПОЛЮСНЫЙ СОЕДИНИТЕЛЬНЫЙ РАЗЪЕМ

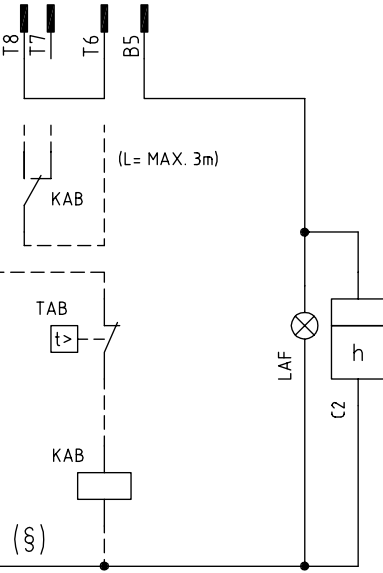

Data	26/06/2008	PREC.	FOGLIO
Revisione	00	/	1
Dis. N.	TAB_1	SEGUE	TOTALE
		2	1

SIGLA/ITEM	FUNZIONE	FUNCTION
C1	CONTAORE BASSA FIAMMA	LOW FLAME TIME COUNTER
C2	CONTAORE ALTA FIAMMA	HIGH FLAME TIME COUNTER
FU1	FUSIBILE LINEA MOTORE VENTILATORE	FAN MOTOR LINE FUSE
FU3	FUSIBILE LINEA BRUCIATORE	BURNER LINE FUSE
IL	INTERRUTTORE LINEA BRUCIATORE	BURNER LINE SWITCH
IM	INTERRUTTORE LINEA MOTORE VENTILATORE	FAN MOTOR LINE SWITCH
KAB	RELE' AUSILIARIO	AUXILIARY RELAY
LAF	LAMPADA SEGNALAZIONE ALTA FIAMMA BRUCIATORE	BURNER IN HIGH FLAME INDICATOR LIGHT
LB	LAMPADA SEGNALAZIONE BLOCCO BRUCIATORE	INDICATOR LIGHT FOR BURNER LOCK-OUT
LBF	LAMPADA SEGNALAZIONE BASSA FIAMMA BRUCIATORE	BURNER IN LOW FLAME INDICATOR LIGHT
ST	SERIE TERMOSTATI/PRESSOSTATI	SERIES OF THERMOSTATS OR PRESSURE SWITCHES
TAB	TERMOSTATO/PRESSOSTATO ALTA-BASSA FIAMMA	HIGH-LOW THERMOSTAT/PRESSURE SWITCHES
TS	TERMOSTATO/PRESSOSTATO DI SICUREZZA	SAFETY THERMOSTAT OR PRESSURE SWITCH

SIGLA/ITEM	FUNZIONE	FUNCTION
C1	CONTAORE BASSA FIAMMA	СЧЕТЧИК ЧАСОВ РАБОТЫ НА МАЛОМ ПЛАМЕНИ
C2	CONTAORE ALTA FIAMMA	СЧЕТЧИК ЧАСОВ РАБОТЫ НА БОЛЬШОМ ПЛАМЕНИ
FU1	FUSIBILE LINEA MOTORE VENTILATORE	ПЛАВКИЙ ПРЕДОХРАНИТЕЛЬ ЛИНИИ ДВИГАТЕЛЯ ВЕНТИЛЯТОРА
FU3	FUSIBILE LINEA BRUCIATORE	ПЛАВКИЙ ПРЕДОХРАНИТЕЛЬ ЛИНИИ ГОРЕЛКИ
IL	INTERRUTTORE LINEA BRUCIATORE	ВЫКЛЮЧАТЕЛЬ ЛИНИИ ГОРЕЛКИ
IM	INTERRUTTORE LINEA MOTORE VENTILATORE	ВЫКЛЮЧАТЕЛЬ ЛИНИИ ДВИГАТЕЛЯ ВЕНТИЛЯТОРА
KAB	RELE' AUSILIARIO	ВСПОМОГАТЕЛЬНОЕ РЕЛЕ
LAF	LAMPADA SEGNALAZIONE ALTA FIAMMA BRUCIATORE	СИГНАЛЬНАЯ ЛАМПОЧКА БОЛЬШОГО ПЛАМЕНИ ГОРЕЛКИ
LB	LAMPADA SEGNALAZIONE BLOCCO BRUCIATORE	СИГНАЛЬНАЯ ЛАМПОЧКА БЛОКИРОВКИ ГОРЕЛКИ
LBF	LAMPADA SEGNALAZIONE BASSA FIAMMA BRUCIATORE	СИГНАЛЬНАЯ ЛАМПОЧКА МАЛОГО ПЛАМЕНИ ГОРЕЛКИ
ST	SERIE TERMOSTATI/PRESSOSTATI	РЯД ТЕРМОСТАТОВ/РЕЛЕ ДАВЛЕНИЯ
TAB	TERMOSTATO/PRESSOSTATO ALTA-BASSA FIAMMA	ТЕРМОСТАТ/РЕЛЕ ДАВЛЕНИЯ БОЛЬШОГО/МАЛОГО ПЛАМЕНИ
TS	TERMOSTATO/PRESSOSTATO DI SICUREZZA	ПРЕДОХРАНИТЕЛЬНЫЙ ТЕРМОСТАТ/ РЕЛЕ ДАВЛЕНИЯ

Data	26/06/2008	PREC.	FOGLIO
Revisione	00	1	2
Dis. N.	TAB_1	SEGUE	TOTALE
		/	1



VERSIONE MONOSTADIO "TN" "TN" SINGLE-STAGE VERSION

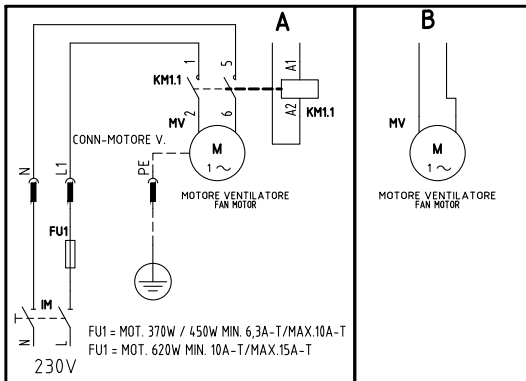
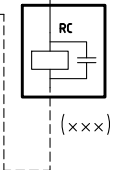
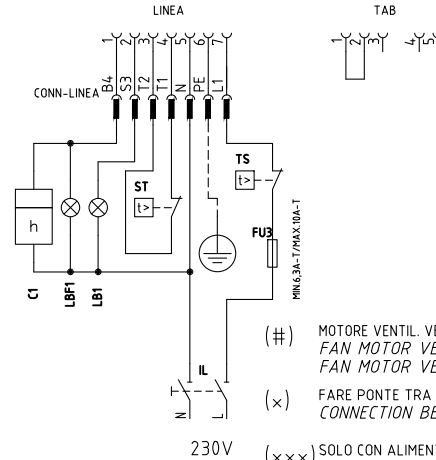
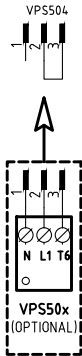
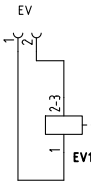
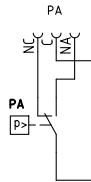
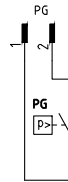
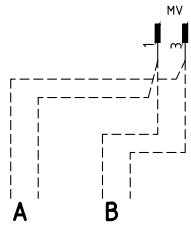
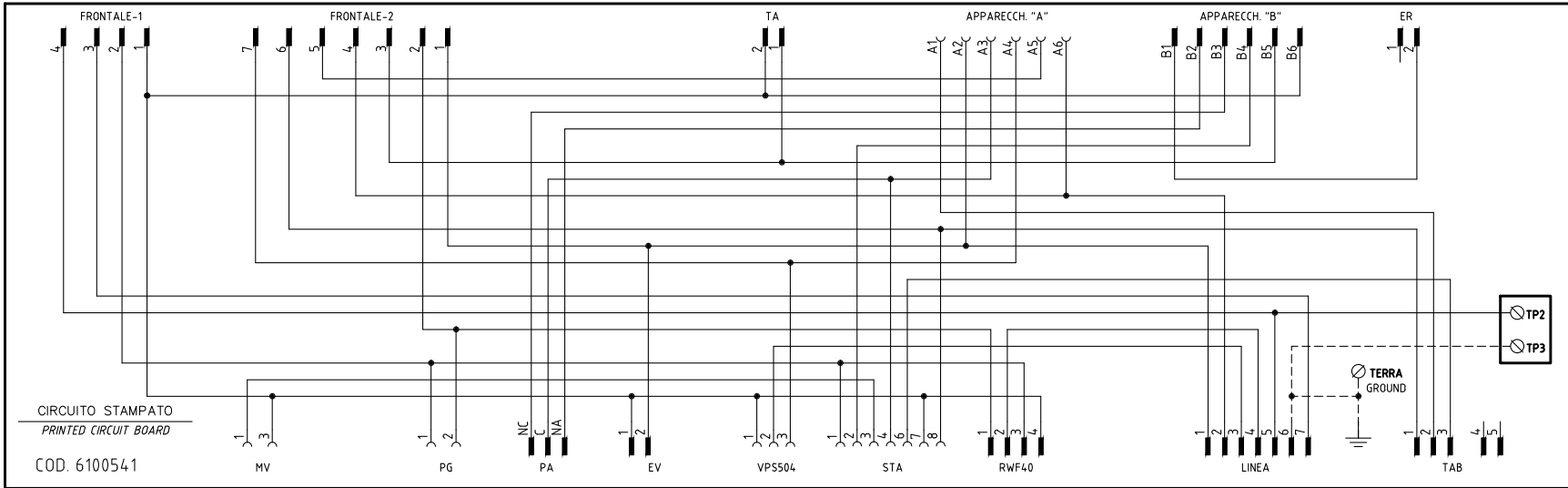
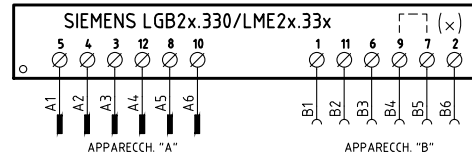
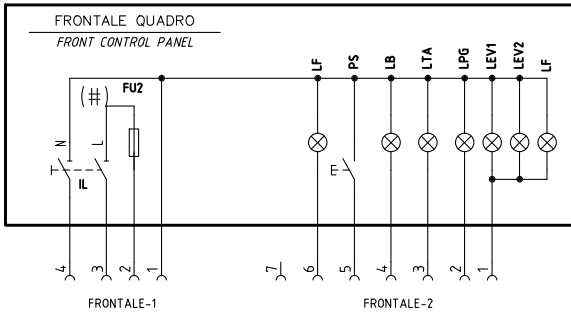

- (#) MOTORE VENTIL. VERSIONE [A], FU2 = 6,3A F; MOTORE VENTIL. VERSIONE [B], FU2 = 10A F
FAN MOTOR VERSION [A], FU2 = 6,3 A F;
FAN MOTOR VERSION [B], FU2 = 10 A F
- (x) FARE PONTE TRA I MORSETTI 7 E 9 SOLO CON LGB21.330
CONNECTION BETWEEN TERMINALS 7 AND 9 WITH LGB21.330 ONLY
- (x x x) SOLO CON ALIMENTAZIONE ELETTRICA SENZA NEUTRO
WITH ELECTRIC SUPPLY WITHOUT NEUTRAL VERSION ONLY

REV.	MODIFICA	DATA	FIRME
05	AGGIUNTO/ADDED "KVB" ASCON	07/08/14	U. PINTON
04	AGGIUNTO/ADDED "600V"	19/06/12	U. PINTON
03	AGGIUNTO/ADDED "RWF502x"	20/01/12	U. PINTON
02	MOTOR MODIFY	19/10/10	U. PINTON
01	AGGIUNTO / ADDED SGM72...	22/05/09	U. PINTON

	Impianto TIPI/TYPES NG(X)350/400/550 - LG(X)350/400/550 MODELLI/MODELS x-.TN(PR)(MD).x.xx.A.x.xx	Ordine	19/10/2010	PREC.	FOGLIO	
	Descrizione VERSIONE CON CIRCUITO STAMPATO WITH PRINTED CIRCUIT VERSION	Commissa	Data Controllato 07/08/2014	Revisione	05	/
	Esecutore U. PINTON	Controllato E. CAVALLI	Dis. N.	18 - 0163	SEGUE	TOTALE
					2	5

VERSIONE ALTA-BASSA FIAMMA "AB" / PROGRESSIVO "PR"
 "AB" HIGH-LOW / "PR" PROGRESSIVE VERSION

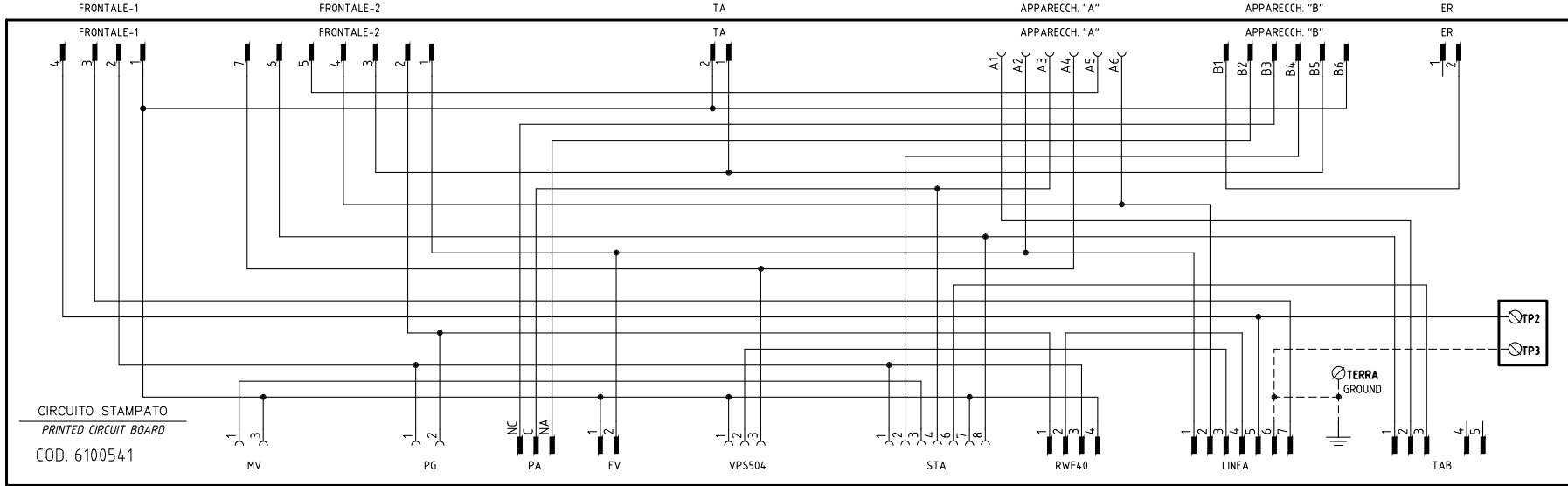
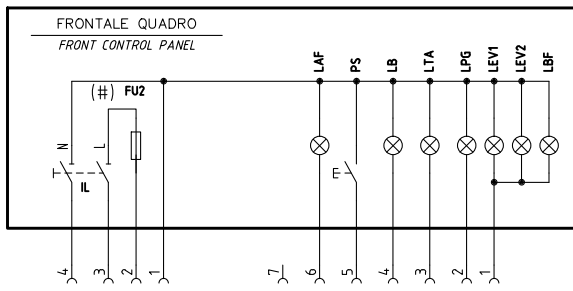

SERVOCOMANDO SERRANDA ARIA
 AIR DAMPER ACTUATOR
 STA13B0.36/83N30L

I ALTA FIAMMA
 HIGH FLAME
 SOSTA
 STAND-BY
 II BASSA FIAMMA
 LOW FLAME
 III NON USATA
 NOT USED

SERVOCOMANDO SERRANDA ARIA
 AIR DAMPER ACTUATOR
 SIEMENS SQNT2.xA4.A20

I (ROSSO) ALTA FIAMMA
 HIGH FLAME
 II (BLU) SOSTA
 STAND-BY
 III (ARANCIO) BASSA FIAMMA
 LOW FLAME
 IV (NERO) NON USATA
 NOT USED

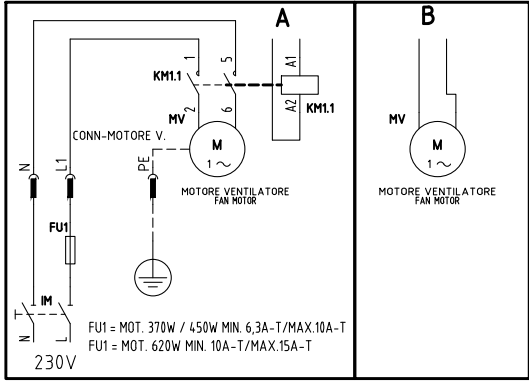
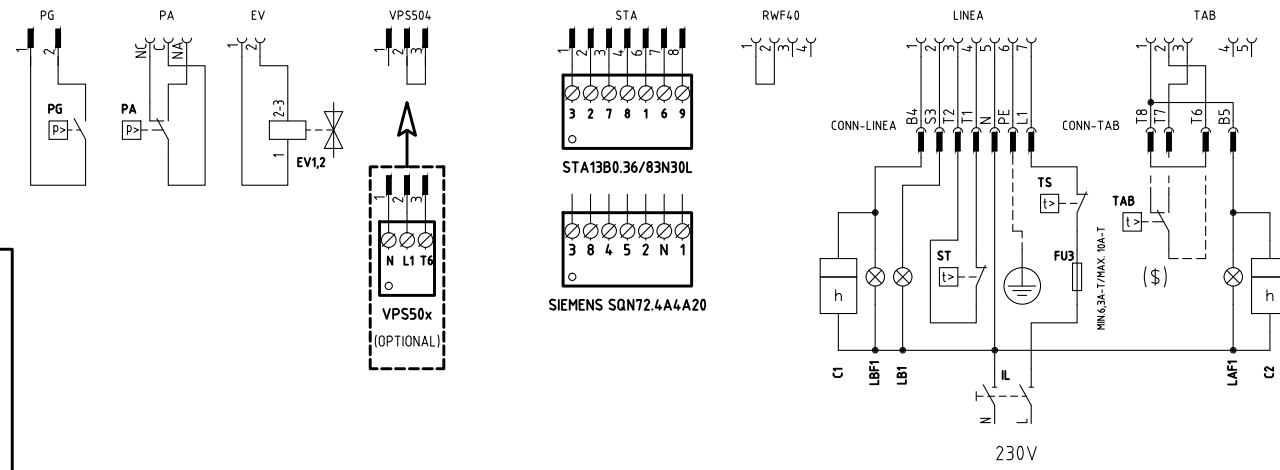
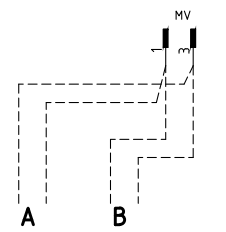

(#) MOTORE VENTIL. VERSIONE [A], FU2 = 6,3A F; MOTORE VENTIL. VERSIONE [B], FU2 = 10A F
 FAN MOTOR VERSION [A], FU2 = 6,3 A F;
 FAN MOTOR VERSION [B], FU2 = 10 A F

(x x x) SOLO CON ALIMENTAZIONE ELETTRICA SENZA NEUTRO
 WITH ELECTRIC SUPPLY WITHOUT NEUTRAL VERSION ONLY

(\$) SE USATO "TAB", TOGLIERE IL PONTE TRA I MORSETTI T6-T8
 IF USED "TAB", REMOVE THE BRIDGE BETWEEN TERMINALS T6-T8

Data	19/10/2010	PREC.	FOGLIO
Revisione	05	1	2
Dis. N.	18 - 0163	SEGUE	TOTALE
		3	5

VERSIONE MODULANTE "MD"
"MD" MODULATING VERSION

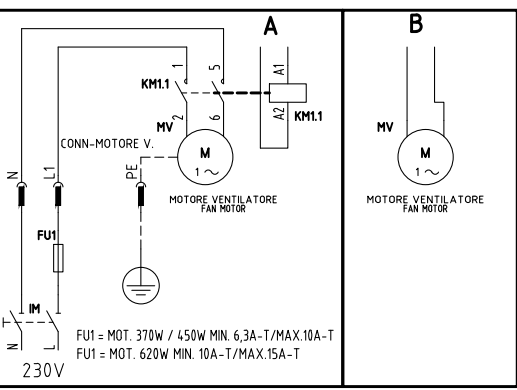
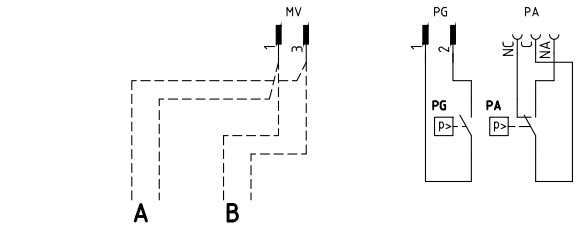
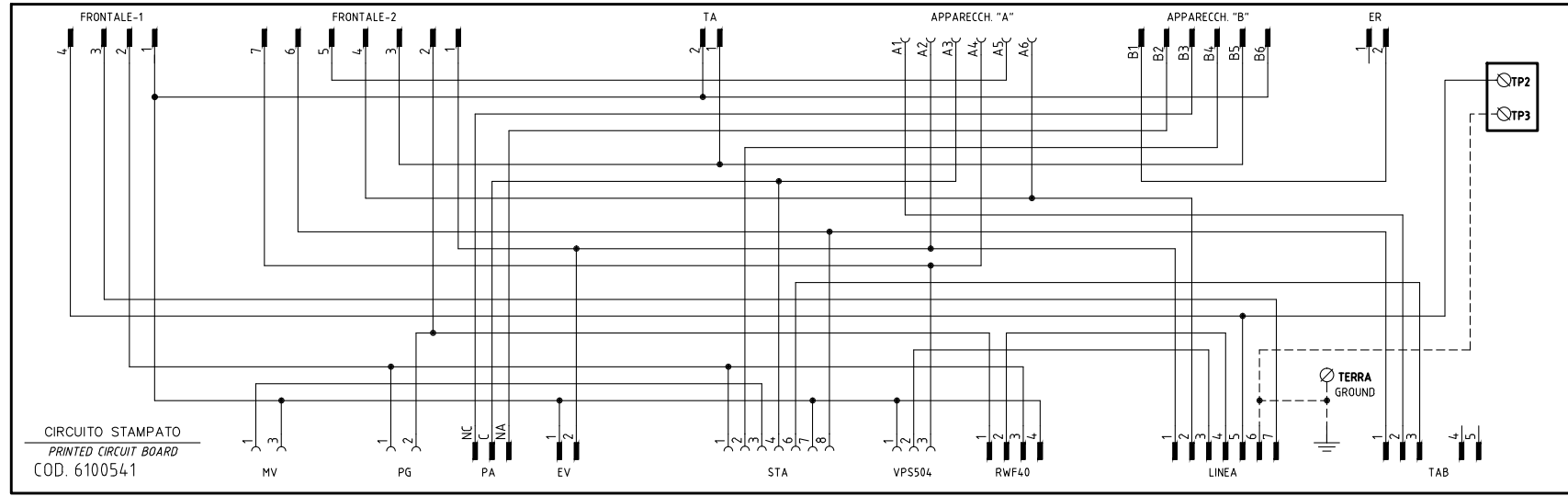
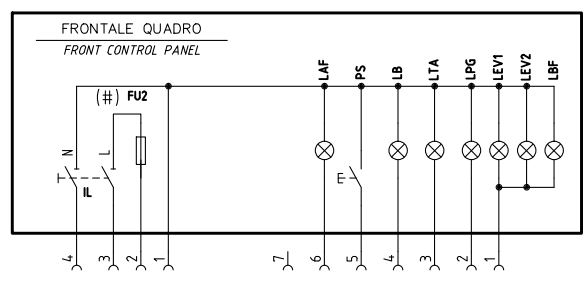

SERVOCOMANDO SERRANDA ARIA
AIR DAMPER ACTUATOR
STA13B0.36/83N30L

I ALTA FIAMMA HIGH FLAME
II SOSTA STAND-BY
III BASSA FIAMMA LOW FLAME
IV NON USATA NOT USED

SERVOCOMANDO SERRANDA ARIA
AIR DAMPER ACTUATOR
SIEMENS SQN72.xA4.A20

I (ROSSO) ALTA FIAMMA HIGH FLAME
II (BLU) SOSTA STAND-BY
III (ARANCIO) BASSA FIAMMA LOW FLAME
IV (NERO) NON USATA NOT USED

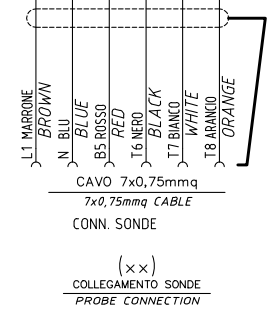
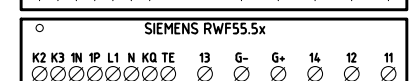
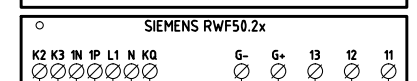
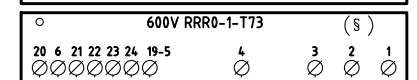
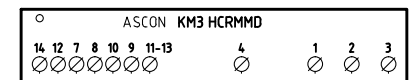
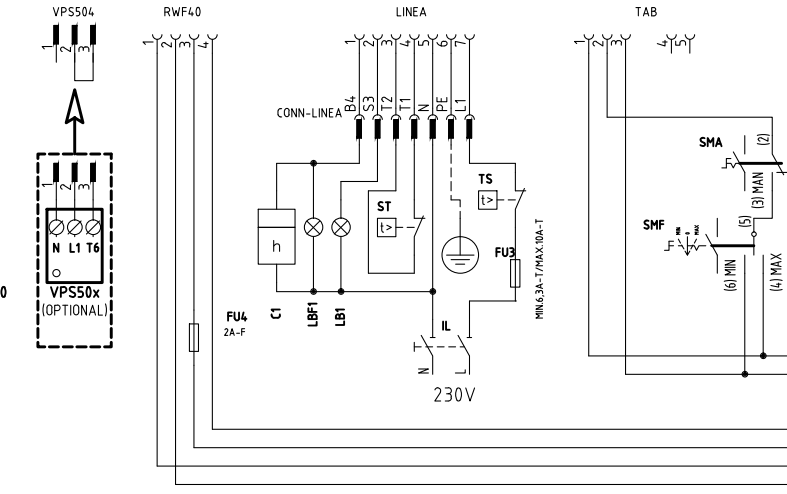
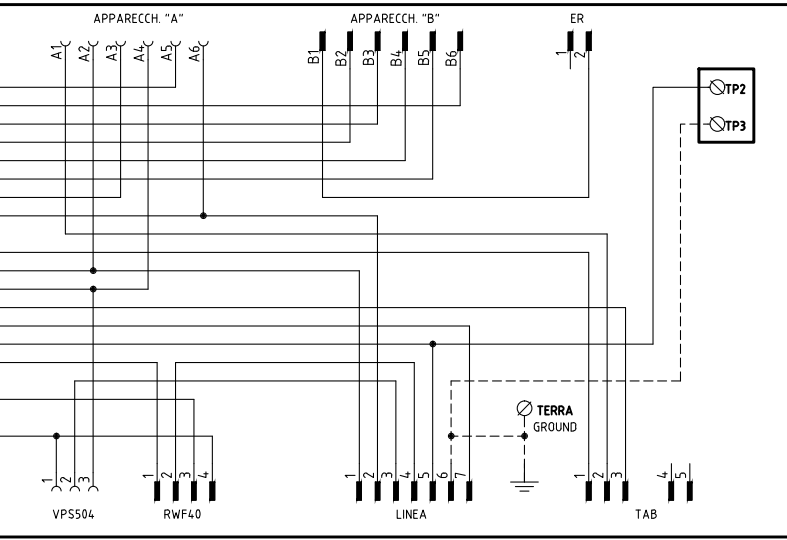
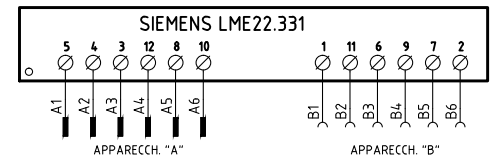

(#) MOTORE VENTIL. VERSIONE [A], FU2 = 6,3A F; MOTORE VENTIL. VERSIONE [B], FU2 = 10A F
FAN MOTOR VERSION [A], FU2= 6,3 A F;
FAN MOTOR VERSION [B], FU2= 10 A F

(x x x) SOLO CON ALIMENTAZIONE ELETTRICA SENZA NEUTRO
WITH ELECTRIC SUPPLY WITHOUT NEUTRAL VERSION ONLY

Data	19/10/2010	PREC.	FOGLIO
Revisione	05	2	3
Dis. N.	18 - 0163	SEQUE	TOTALE
		4	5

(xx)
 ATTENZIONE COLLEGAMENTO SONDE CON CONNETTORE 7 POLI
 WARNING PROBE CONNECTION WITH 7 PINS CONNECTOR

KM3 HCRMMD

600V RRR0-1-T73

RWF55.5x

RWF50.2x

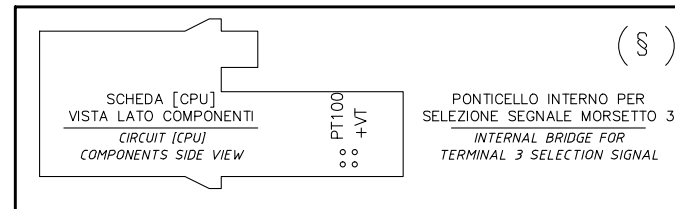
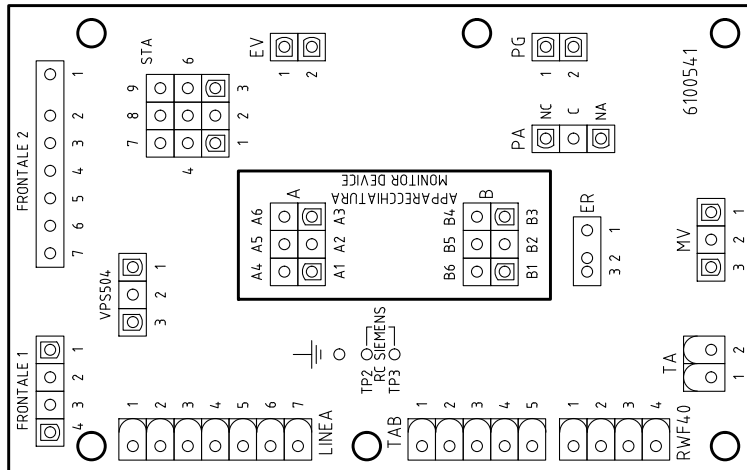
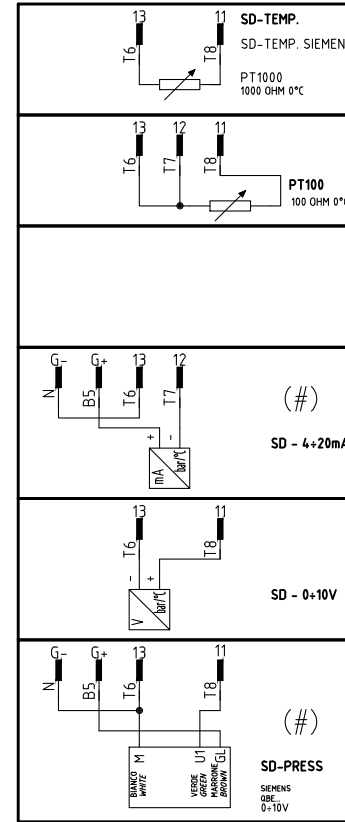
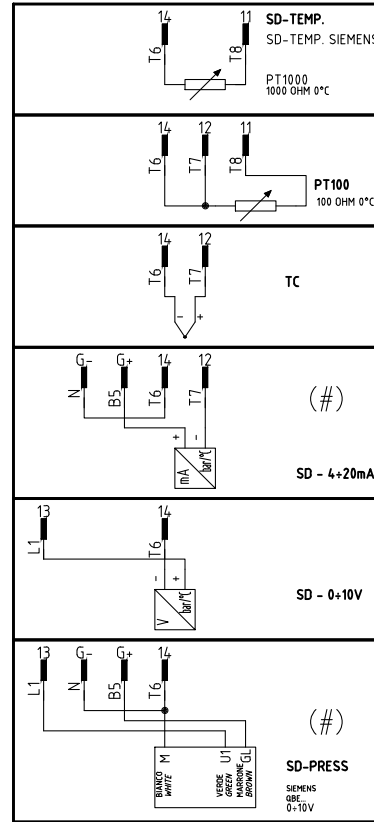
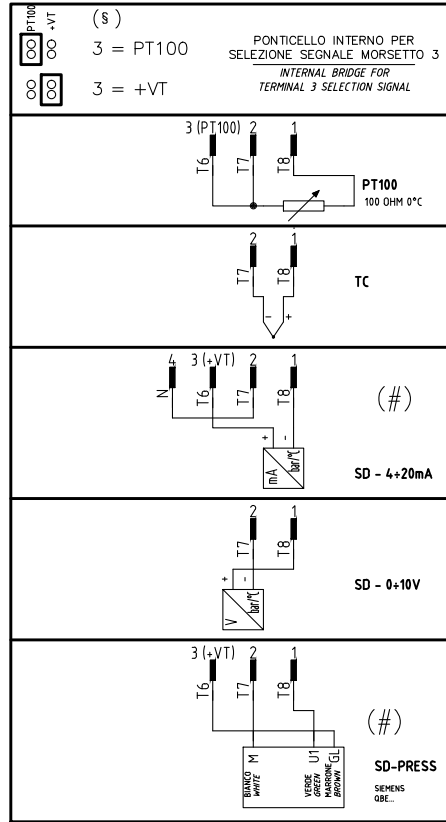
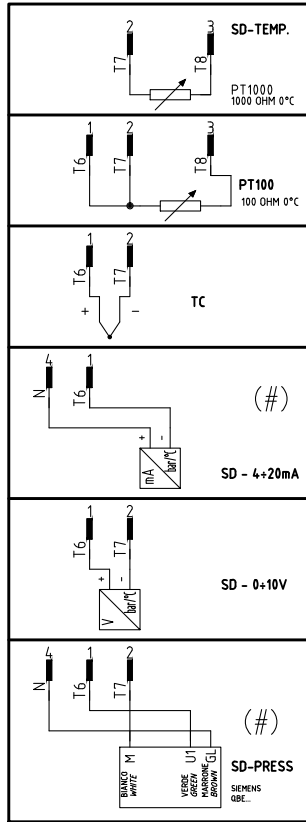

Data	19/10/2010	PREC.	FOGLIO
Revisione	05	3	4
Dis. N.	18 - 0163	SEGUE	TOTALE
		5	5

Sigla/Item	Funzione	Function
600V RRR0-1-T73	REGOLATORE MODULANTE (ALTERNATIVO)	BURNER MODULATOR (ALTERNATIVE)
C1	CONTAORE BASSA FIAMMA	LOW FLAME TIME COUNTER
C2	CONTAORE ALTA FIAMMA	HIGH FLAME TIME COUNTER
ER	ELETTRODO RILEVAZIONE FIAMMA	FLAME DETECTION ELECTRODE
EV1,2	ELETTROVALVOLE GAS (O GRUPPO VALVOLE)	GAS ELECTRO-VALVES (OR VALVES GROUP)
FU1	FUSIBILE LINEA MOTORE VENTILATORE	FAN MOTOR LINE FUSE
FU2	FUSIBILE DI LINEA	LINE FUSE
FU3	FUSIBILE DI LINEA	LINE FUSE
FU4	FUSIBILE AUSILIARIO	AUXILIARY FUSE
IL	INTERRUTTORE LINEA BRUCIATORE	BURNER LINE SWITCH
IM	INTERRUTTORE LINEA MOTORE VENTILATORE	FAN MOTOR LINE SWITCH
KM1.1	CONTATTORE MOTORE VENTILATORE	FAN MOTOR CONTACTOR
KM3 HCRMMD	REGOLATORE MODULANTE (ALTERNATIVO)	BURNER MODULATOR (ALTERNATIVE)
LAF	LAMPADA SEGNALAZIONE ALTA FIAMMA BRUCIATORE	BURNER IN HIGH FLAME INDICATOR LIGHT
LAF1	LAMPADA SEGNALAZIONE ALTA FIAMMA BRUCIATORE	BURNER IN HIGH FLAME INDICATOR LIGHT
LB	LAMPADA SEGNALAZIONE BLOCCO BRUCIATORE	INDICATOR LIGHT FOR BURNER LOCK-OUT
LB1	LAMPADA SEGNALAZIONE BLOCCO BRUCIATORE	INDICATOR LIGHT FOR BURNER LOCK-OUT
LBF	LAMPADA SEGNALAZIONE BASSA FIAMMA BRUCIATORE	BURNER IN LOW FLAME INDICATOR LIGHT
LBF1	LAMPADA SEGNALAZIONE BASSA FIAMMA BRUCIATORE	BURNER IN LOW FLAME INDICATOR LIGHT
LEV1	LAMPADA SEGNALAZIONE APERTURA [EV1]	INDICATOR LIGHT FOR OPENING OF ELECTRO-VALVE [EV1]
LEV2	LAMPADA SEGNALAZIONE APERTURA [EV2]	INDICATOR LIGHT FOR OPENING OF ELECTRO-VALVE [EV2]
LF	LAMPADA SEGNALAZIONE FUNZIONAMENTO BRUCIATORE	INDICATOR LIGHT BURNER OPERATION
LPG	LAMPADA SEGNALAZIONE PRESENZA GAS IN RETE	INDICATOR LIGHT FOR PRESENCE OF GAS IN THE NETWORK
LTA	LAMPADA SEGNALAZIONE TRASFORMATORE DI ACCENSIONE	IGNITION TRANSFORMER INDICATOR LIGHT
MV	MOTORE VENTILATORE	FAN MOTOR
PA	PRESSOSTATO ARIA	AIR PRESSURE SWITCH
PG	PRESSOSTATO GAS DI MINIMA PRESSIONE	MINIMUM GAS PRESSURE SWITCH
PS	PULSANTE SBLOCCO FIAMMA	FLAME UNLOCK BUTTON
PT100	SONDA DI TEMPERATURA	TEMPERATURE PROBE
RC	CIRCUITO RC	RC CIRCUIT
SD-PRESS	SONDA DI PRESSIONE	PRESSURE PROBE
SD-TEMP.	SONDA DI TEMPERATURA	TEMPERATURE PROBE
SD - 0÷10V	TRASDUTTORE USCITA IN TENSIONE	TRANSDUCER VOLTAGE OUTPUT
SD - 4÷20mA	TRASDUTTORE USCITA IN CORRENTE	TRANSDUCER CURRENT OUTPUT
SIEMENS LGB2x.330/LME2x.33x	APPARECCHIATURA CONTROLLO FIAMMA	CONTROL BOX
SIEMENS LME22.331	APPARECCHIATURA CONTROLLO FIAMMA	CONTROL BOX
SIEMENS RWF50.2x	REGOLATORE MODULANTE	BURNER MODULATOR
SIEMENS RWF55.5x	REGOLATORE MODULANTE (ALTERNATIVO)	BURNER MODULATOR (ALTERNATIVE)
SIEMENS SQN72.4A4A20	SERVOCOMANDO SERRANDA ARIA (ALTERNATIVO)	AIR DAMPER ACTUATOR (ALTERNATIVE)
SMA	SELETTORE MANUALE/AUTOMATICO	MANUAL/AUTOMATIC SWITCH
SMF	SELETTORE MANUALE FUNZIONAMENTO MIN-0-MAX	MIN-0-MAX MANUAL OPERATION SWITCH
ST	SERIE TERMOSTATI/PRESSOSTATI	SERIES OF THERMOSTATS OR PRESSURE SWITCHES
STA13B0.36/83N30L	SERVOCOMANDO SERRANDA ARIA	AIR DAMPER ACTUATOR
TA	TRASFORMATORE DI ACCENSIONE	IGNITION TRANSFORMER
TAB	TERMOSTATO/PRESSOSTATO ALTA-BASSA FIAMMA	HIGH-LOW THERMOSTAT/PRESSURE SWITCHES
TC	TERMOCOPPIA	THERMOCOUPLE
TS	TERMOSTATO/PRESSOSTATO DI SICUREZZA	SAFETY THERMOSTAT OR PRESSURE SWITCH
VPS50x	CONTROLLO DI TENUTA VALVOLE GAS (OPTIONAL)	GAS PROVING SYSTEM (OPTIONAL)

Data	19/10/2010	PREC.	FOGLIO
Revisione	05	4	5
Dis. N.	18 - 0163	SEGUE	TOTALE
		/	5