

# LG/NG/NGX280 LG/NG/NGX350 LG/NG/NGX400



## *Brûleurs à gaz Serie IDEA*

MANUEL D'INSTALLATION - D'UTILISATION - D'ENTRETIEN

**CIB UNIGAS**

BURNERS - BRUCIATORI - BRULERS - BRENNER - QUEMADORES - ГОРЕЛКИ

## DANGERS, WARNINGS AND NOTES OF CAUTION

**THIS MANUAL IS SUPPLIED AS AN INTEGRAL AND ESSENTIAL PART OF THE PRODUCT AND MUST BE DELIVERED TO THE USER.**

**INFORMATION INCLUDED IN THIS SECTION ARE DEDICATED BOTH TO THE USER AND TO PERSONNEL FOLLOWING PRODUCT INSTALLATION AND MAINTENANCE.**

**THE USER WILL FIND FURTHER INFORMATION ABOUT OPERATING AND USE RESTRICTIONS, IN THE SECOND SECTION OF THIS MANUAL. WE HIGHLY RECOMMEND TO READ IT.**

**CAREFULLY KEEP THIS MANUAL FOR FUTURE REFERENCE.**

### 1) GENERAL INTRODUCTION

- The equipment must be installed in compliance with the regulations in force, following the manufacturer's instructions, by qualified personnel.
- Qualified personnel means those having technical knowledge in the field of components for civil or industrial heating systems, sanitary hot water generation and particularly service centres authorised by the manufacturer.
- Improper installation may cause injury to people and animals, or damage to property, for which the manufacturer cannot be held liable.
- Remove all packaging material and inspect the equipment for integrity. In case of any doubt, do not use the unit - contact the supplier.

The packaging materials (wooden crate, nails, fastening devices, plastic bags, foamed polystyrene, etc), should not be left within the reach of children, as they may prove harmful.

- Before any cleaning or servicing operation, disconnect the unit from the mains by turning the master switch OFF, and/or through the cut-out devices that are provided.
- Make sure that inlet or exhaust grilles are unobstructed.
- In case of breakdown and/or defective unit operation, disconnect the unit. Make no attempt to repair the unit or take any direct action.

Contact qualified personnel only.

Units shall be repaired exclusively by a servicing centre, duly authorised by the manufacturer, with original spare parts and accessories.

Failure to comply with the above instructions is likely to impair the unit's safety.

To ensure equipment efficiency and proper operation, it is essential that maintenance operations are performed by qualified personnel at regular intervals, following the manufacturer's instructions.

- When a decision is made to discontinue the use of the equipment, those parts likely to constitute sources of danger shall be made harmless.
- In case the equipment is to be sold or transferred to another user, or in case the original user should move and leave the unit behind, make sure that these instructions accompany the equipment at all times so that they can be consulted by the new owner and/or the installer.
- This unit shall be employed exclusively for the use for which it is meant. Any other use shall be considered as improper and, therefore, dangerous.

The manufacturer shall not be held liable, by agreement or otherwise, for damages resulting from improper installation, use and failure to comply with the instructions supplied by the manufacturer. The occurrence of any of the following circumstances may cause explosions, polluting unburnt gases (example: carbon monoxide CO), burns, serious harm to people, animals and things:

- Failure to comply with one of the WARNINGS in this chapter
- Incorrect handling, installation, adjustment or maintenance of the burner
- Incorrect use of the burner or incorrect use of its parts or optional supply

### 2) SPECIAL INSTRUCTIONS FOR BURNERS

- The burner should be installed in a suitable room, with ventilation openings complying with the requirements of the regulations in force, and sufficient for good combustion.
- Only burners designed according to the regulations in force should be used.
- This burner should be employed exclusively for the use for which it was designed.
- Before connecting the burner, make sure that the unit rating is the same as delivery mains (electricity, gas oil, or other fuel).
- Observe caution with hot burner components. These are, usually, near to the flame and the fuel pre-heating system, they become hot during the unit operation and will remain hot for some time after the burner has stopped.

When the decision is made to discontinue the use of the burner, the user shall have qualified personnel carry out the following operations:

- a Remove the power supply by disconnecting the power cord from the mains.
- b Disconnect the fuel supply by means of the hand-operated shut-off valve and remove the control handwheels from their spindles.

#### Special warnings

- Make sure that the burner has, on installation, been firmly secured to the appliance, so that the flame is generated inside the appliance fire-box.
- Before the burner is started and, thereafter, at least once a year, have qualified personnel perform the following operations:
  - a set the burner fuel flow rate depending on the heat input of the appliance;
  - b set the flow rate of the combustion-supporting air to obtain a combustion efficiency level at least equal to the lower level required by the regulations in force;
  - c check the unit operation for proper combustion, to avoid any harmful or polluting unburnt gases in excess of the limits permitted by the regulations in force;
  - d make sure that control and safety devices are operating properly;
  - e make sure that exhaust ducts intended to discharge the products of combustion are operating properly;
  - f on completion of setting and adjustment operations, make sure that all mechanical locking devices of controls have been duly tightened;
  - g make sure that a copy of the burner use and maintenance instructions is available in the boiler room.
- In case of a burner shut-down, reset the control box by means of the RESET pushbutton. If a second shut-down takes place, call the Technical Service, **without trying to RESET further**.
- The unit shall be operated and serviced by qualified personnel only, in compliance with the regulations in force.

### 3) GENERAL INSTRUCTIONS DEPENDING ON FUEL USED

#### 3a) ELECTRICAL CONNECTION

- For safety reasons the unit must be efficiently earthed and installed as required by current safety regulations.
- It is vital that all safety requirements are met. In case of any doubt, ask for an accurate inspection of electrics by qualified personnel, since the manufacturer cannot be held liable for damages that may be caused by failure to correctly earth the equipment.
- Qualified personnel must inspect the system to make sure that it is adequate to take the maximum power used by the equipment shown on the equipment rating plate. In particular, make sure that the system cable cross section is adequate for the power absorbed by the unit.
- No adaptors, multiple outlet sockets and/or extension cables are permitted to connect the unit to the electric mains.
- An omnipolar switch shall be provided for connection to mains, as required by the current safety regulations.
- The use of any power-operated component implies observance of a few basic rules, for example:
  - do not touch the unit with wet or damp parts of the body and/or with bare feet;
  - do not pull electric cables;
  - do not leave the equipment exposed to weather (rain, sun, etc.) unless expressly required to do so;
  - do not allow children or inexperienced persons to use equipment;
- The unit input cable shall not be replaced by the user. In case of damage to the cable, switch off the unit and contact qualified personnel to replace. When the unit is out of use for some time the electric switch supplying all the power-driven components in the system (i.e. pumps, burner, etc.) should be switched off.

### 3b) FIRING WITH GAS, LIGHT OIL OR OTHER FUELS

#### GENERAL

- The burner shall be installed by qualified personnel and in compliance with regulations and provisions in force; wrong installation can cause injuries to people and animals, or damage to property, for which the manufacturer cannot be held liable.
- Before installation, it is recommended that all the fuel supply system pipes be carefully cleaned inside, to remove foreign matter that might impair the burner operation.
- Before the burner is commissioned, qualified personnel should inspect the following:
  - a the fuel supply system, for proper sealing;
  - b the fuel flow rate, to make sure that it has been set based on the firing rate required of the burner;
  - c the burner firing system, to make sure that it is supplied for the designed fuel type;
  - d the fuel supply pressure, to make sure that it is included in the range shown on the rating plate;
  - e the fuel supply system, to make sure that the system dimensions are adequate to the burner firing rate, and that the system is equipped with all the safety and control devices required by the regulations in force.
- When the burner is to remain idle for some time, the fuel supply tap or taps should be closed.

#### SPECIAL INSTRUCTIONS FOR USING GAS

Have qualified personnel inspect the installation to ensure that:

- a the gas delivery line and train are in compliance with the regulations and provisions in force;
  - b all gas connections are tight;
  - c the boiler room ventilation openings are such that they ensure the air supply flow required by the current regulations, and in any case are sufficient for proper combustion.
- Do not use gas pipes to earth electrical equipment.
  - Never leave the burner connected when not in use. Always shut the gas valve off.
  - In case of prolonged absence of the user, the main gas delivery valve to the burner should be shut off.

#### Precautions if you can smell gas

- a do not operate electric switches, the telephone, or any other item likely to generate sparks;
  - b immediately open doors and windows to create an air flow to purge the room;
  - c close the gas valves;
  - d contact qualified personnel.
- Do not obstruct the ventilation openings of the room where gas appliances are installed, to avoid dangerous conditions such as the development of toxic or explosive mixtures.

### DIRECTIVES AND STANDARDS

#### *Gas burners*

##### European directives

- Regulation 2016/426/UE (appliances burning gaseous fuels)
- 2014/35/UE (Low Tension Directive)
- 2014/30/UE (Electromagnetic compatibility Directive)
- 2006/42/EC (Machinery Directive)

##### Harmonized standards

- UNI EN 676 (Automatic forced draught burners for gaseous fuels)
- EN 55014-1 (Electromagnetic compatibility- Requirements for household appliances, electric tools and similar apparatus)
- EN 60204-1:2006 (Safety of machinery – Electrical equipment of machines.)
- CEI EN 60335-1 (Specification for safety of household and similar electrical appliances);
- CEI EN 60335-2-102 (Household and similar electrical appliances. Safety. Particular requirements for gas, oil and solid-fuel burning appliances having electrical connections).
- UNI EN ISO 12100:2010 (Safety of machinery - General principles for design - Risk assessment and risk reduction);

#### *Light oil burners*

##### European directives

- 2014/35/UE (Low Tension Directive)
- 2014/30/UE (Electromagnetic compatibility Directive)
- 2006/42/EC (Machinery Directive)

##### Harmonized standards

- UNI EN 267-2011(Automatic forced draught burners for liquid fuels)
- EN 55014-1 (Electromagnetic compatibility- Requirements for household appliances, electric tools and similar apparatus)
- EN 60204-1:2006 (Safety of machinery – Electrical equipment of machines.)
- CEI EN 60335-1 (Specification for safety of household and similar electrical appliances);
- CEI EN 60335-2-102 (Household and similar electrical appliances. Safety. Particular requirements for gas, oil and solid-fuel burning appliances having electrical connections).
- UNI EN ISO 12100:2010 (Safety of machinery - General principles for design - Risk assessment and risk reduction);

#### *Heavy oil burners*

##### European Directives

- 2014/35/UE (Low Tension Directive)
- 2014/30/UE (Electromagnetic compatibility Directive)
- 2006/42/EC (Machinery Directive)

##### Harmonized standards

- UNI EN 267(Automatic forced draught burners for liquid fuels)
- EN 55014-1 (Electromagnetic compatibility- Requirements for household appliances, electric tools and similar apparatus)
- EN 60204-1:2006 (Safety of machinery – Electrical equipment of machines.)
- CEI EN 60335-1 (Specification for safety of household and similar electrical appliances);
- CEI EN 60335-2-102 (Household and similar electrical appliances. Safety. Particular requirements for gas, oil and solid-fuel burning appliances having electrical connections).
- UNI EN ISO 12100:2010 (Safety of machinery - General principles for design - Risk assessment and risk reduction);

### Gas - Light oil burners

#### European Directives

- Regulation 2016/426/UE (appliances burning gaseous fuels)
- 2014/35/UE (Low Tension Directive)
- 2014/30/UE (Electromagnetic compatibility Directive)
- 2006/42/EC (Machinery Directive)

#### Harmonized standards

- UNI EN 676 (Automatic forced draught burners for gaseous fuels)
- UNI EN 267 (Automatic forced draught burners for liquid fuels)
- EN 55014-1 (Electromagnetic compatibility- Requirements for household appliances, electric tools and similar apparatus)
- EN 60204-1:2006 (Safety of machinery – Electrical equipment of machines.)
- CEI EN 60335-1 (Specification for safety of household and similar electrical appliances);
- CEI EN 60335-2-102 (Household and similar electrical appliances. Safety. Particular requirements for gas, oil and solid-fuel burning appliances having electrical connections).
- UNI EN ISO 12100:2010 (Safety of machinery - General principles for design - Risk assessment and risk reduction);

### Gas - Heavy oil burners

#### European directives:

- Regulation 2016/426/UE (appliances burning gaseous fuels)
- 2014/35/UE (Low Tension Directive)
- 2014/30/UE (Electromagnetic compatibility Directive)
- 2006/42/EC (Machinery Directive)

#### Harmonized standards

- UNI EN 676 (Automatic forced draught burners for gaseous fuels)
- EN 55014-1 (Electromagnetic compatibility- Requirements for household appliances, electric tools and similar apparatus)
- EN 60204-1:2006 (Safety of machinery – Electrical equipment of machines.)
- CEI EN 60335-1 (Specification for safety of household and similar electrical appliances);
- CEI EN 60335-2-102 (Household and similar electrical appliances. Safety. Particular requirements for gas, oil and solid-fuel burning appliances having electrical connections).
- UNI EN ISO 12100:2010 (Safety of machinery - General principles for design - Risk assessment and risk reduction);

### Industrial burners

#### European directives

- Regulation 2016/426/UE (appliances burning gaseous fuels)
- 2014/35/UE (Low Tension Directive)
- 2014/30/UE (Electromagnetic compatibility Directive)
- 2006/42/EC (Machinery Directive)

#### Harmonized standards

- EN 55014-1 (Electromagnetic compatibility- Requirements for household appliances, electric tools and similar apparatus)
- EN 746-2 (Industrial thermoprocessing equipment - Part 2: Safety requirements for combustion and fuel handling systems)
- UNI EN ISO 12100:2010 (Safety of machinery - General principles for design - Risk assessment and risk reduction);
- EN 60204-1:2006 (Safety of machinery – Electrical equipment of machines.)
- EN 60335-2 (Electrical equipment of non-electric appliances for household and similar purposes. Safety requirements)

### Burner data plate

For the following information, please refer to the data plate:

- burner type and burner model: must be reported in any communication with the supplier
- burner ID (serial number): must be reported in any communication with the supplier
- date of production (year and month)
- information about fuel type and network pressure

Type	--
Model	--
Year	--
S.Number	--
Output	--
Oil Flow	--
Fuel	--
Category	--
Gas Pressure	--
Viscosity	--
El.Supply	--
El.Consump.	--
Fan Motor	--
Protection	--
Drwaing n°	--
P.I.N.	--

### SYMBOLS USED



**WARNING!**

Failure to observe the warning may result in irreparable damage to the unit or damage to the environment



**DANGER!**

Failure to observe the warning may result in serious injuries or death.



**WARNING!**

Failure to observe the warning may result in electric shock with lethal consequences

Figures, illustrations and images used in this manual may differ in appearance from the actual product.

### BURNER SAFETY

The burners - and the configurations described below - comply with the regulations in force regarding health, safety and the environment. For more in-depth information, refer to the declarations of conformity that are an integral part of this Manual.



**DANGER! Incorrect motor rotation can seriously damage property and injure people.**

### Residual risks deriving from misuse and prohibitions

The burner has been built in order to make its operation safe; there are, however, residual risks.



Do not touch any mechanical moving parts with your hands or any other part of your body. Injury hazard  
Do not touch any parts containing fuel (i.e. tank and pipes). Scalding hazard  
Do not use the burner in situations other than the ones provided for in the data plate.  
Do not use fuels other than the ones stated.  
Do not use the burner in potentially explosive environments.  
Do not remove or by-pass any machine safety devices.  
Do not remove any protection devices or open the burner or any other component while the burner is running.  
Do not disconnect any part of the burner or its components while the burner is running.  
Untrained staff must not modify any linkages.



After any maintenance, it is important to restore the protection devices before restarting the machine.  
All safety devices must be kept in perfect working order.  
Personnel authorized to maintain the machine must always be provided with suitable protections.



**ATTENTION:** while running, the parts of the burner near the generator (coupling flange) are subject to overheating. Where necessary, avoid any contact risks by wearing suitable PPE.

## PARTIE I: MANUEL D'INSTALLATION

## CARACTÉRISTIQUES GÉNÉRALES

Le gaz, provenant du réseau de distribution, passe à travers le groupe vannes équipées d'un filtre et d'un stabilisateur. Ce dernier maintient la pression dans les limites d'utilisation. La servocommande électrique qui agit de façon proportionnelle sur les vannes de réglage du débit d'air et le groupe vannes, grâce auquel il est possible de régler le débit du gaz, permettent d'optimiser les valeurs du gaz d'échappement et donc d'obtenir une combustion efficace.

Le positionnement de la tête de combustion à l'aide de la vis de réglage détermine la puissance du brûleur. La tête de combustion détermine la qualité énergétique et la forme géométrique de la flamme. Le combustible et l'air comburant sont acheminés dans des voies géométriques séparées jusqu'à ce qu'ils se croisent dans la zone de développement de la flamme (chambre de combustion). L'entrée forcée de comburant (air) et de combustible (gaz) a lieu dans la chambre de combustion.

- 1 Tableau synoptique avec interrupteur de puissance - tableau électrique
- 2 Rampe gaz
- 3 Filtre à gaz
- 4 Corps de vannes à gaz
- 5 Contrôle des fuites
- 6 Secteur variable (des modèles en deux étapes, progressifs et modulateurs)
- 7 Servomoteur (des modèles en deux étapes, progressifs et modulateurs)
- 8 Couvercle
- 9 Dispositif de contrôle des flammes
- 10 Pressostat d'air
- 11 Moteur ventilateur
- 12 Gueulard + tête de combustion
- 13 Bride
- 14 Bouche

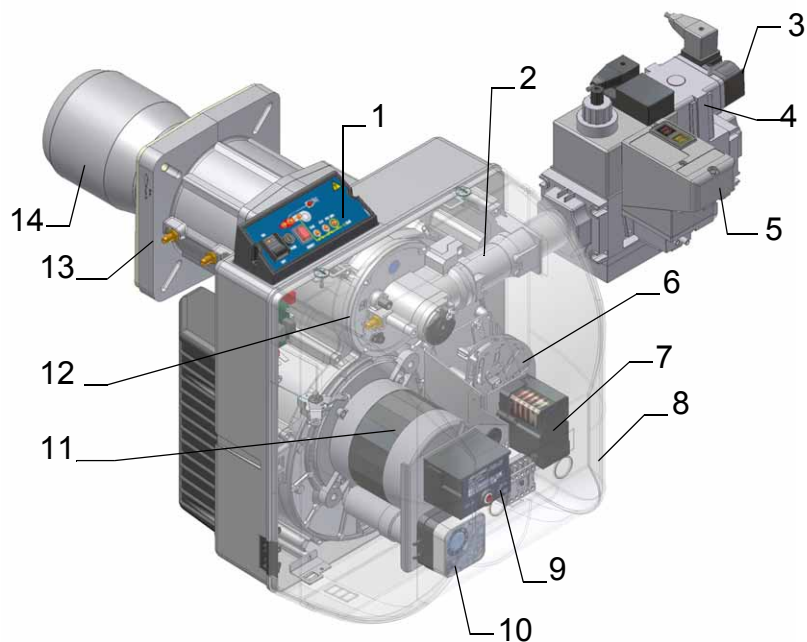

**Identification des brûleurs**

La dénomination du brûleur est identifiée par le type et le modèle. La description du modèle est expliquée ci-dessous.

Type	Modèle	M-	PR.	S.	*	A.	0.	50
(1)	(2)	(3)	(4)	(5)	(6)	(7)	(8)	(9)
(1)	BRULEUR TYPE	NG - Brûleur du gaz naturel LG - Brûleur du G.P.L., NGX - Brûleur à NOx bas						
(2)	COMBUSTIBLE	M - Gaz naturel, L - GPL						
(3)	FONCTIONNEMENT (versions disponibles)	TN - une allure, AB - 2-allures, PR - Progressiv, MD - Modulant						
(4)	LONGUEUR BUSE	S - Standard, L - Longue						
(5)	PAYS DE DESTINATION	* Voir plaquette d'identification						
(6)	VERSIONS SPÉCIALES	A - , Y - Version spécial						
(7)	EQUIPMENT	0 = 2 vannes gaz 1= 2 vannes gaz avec contrôle d'étanchéité (en option) 7 = 2 vannes + pressostat de maxima						
(8)	DIAMÈTRE RAMPE	25 = Rp1, 32 = Rp1¼, 40 = Rp1½, 50 = Rp2						

**DONNES TECHNIQUES**

BRÛLEURS UNE ALLURE		NG280	NG280	NG280	LG280	LG280	LG280
		M-.TN...0.25	M-.TN...0.32	M-.TN...0.40	L-.TN...0.20	L-.TN...0.25	L-.TN...0.32
Puissance maxi. mini.	min.- max. kW	95 - 300					
Combustible		Gaz naturel			G.P.L.		
Catégorie		(voir paragraphe suivant)			I <sub>3B/P</sub>		
Débit gaz	min.- max. (Stm <sup>3</sup> /h)	10 - 32			3,7 - 11,5		
Pression gaz	min.- max. mbar	(voir la note 2) - 360					
Alimentation électrique		110 / 120 / 220 / 230V - 50 / 60 Hz					
Puissance électrique	kW	0,55					
Moteur ventilateur	kW	0,25					
Protection		IP40					
Poids	kg	47					
Diamètre des vannes / Raccordements gaz		1" / Rp1	1"¼ / Rp 1¼	1"½ / Rp 1½	3/4" / Rp3/4	1" / Rp1	1"¼ / Rp 1¼
Type de réglage		une allure					
Température de fonctionnement	°C	-10 ÷ +50					
Température de stockage	°C	-20 ÷ +60					
Type de service*		Intermittent					

BRÛLEURS DEUX ALLURES		NG280	NG280	NG280	LG280	LG280	LG280
		M-.xx...0.25	M-.xx...0.32	M-.xx...0.40	L-.xx...0.20	L-.xx...0.25	L-.xx...0.32
Puissance mini. maxi.	min.- max.	65 - 300					
Combustible		Gaz naturel			G.P.L.		
Catégorie		(voir paragraphe suivant)			I <sub>3B/P</sub>		
Débit gaz mini.- maxi.	min.- max. (Stm <sup>3</sup> /h)	7 - 32			2,5 - 11,5		
Débit gaz mini.- maxi.	min.- max. mbar	(voir la note 2) - 360					
Alimentation électrique		110 / 120 / 220 / 230V - 50 / 60 Hz					
Puissance électrique	kW	0,55					
Moteur ventilateur	kW	0,25					
Protection		IP40					
Poids	kg	47					
Diamètre des vannes / Raccordements gaz		1" / Rp 1	1"¼ / Rp 1¼	1"½ / Rp 1½	1" / Rp1	1" / Rp1	1"¼ / Rp 1¼
Type de réglage		Progressives Modulants					
Température de fonctionnement	°C	-10 ÷ +50					
Température de stockage	°C	-20 ÷ +60					
Type de service*		Intermittent					

<b>BRÛLEURS UNE ALLURE</b>		<b>NG350</b> <b>M-.TN....0.25</b>	<b>NG350</b> <b>M-.TN....0.32</b>	<b>NG350</b> <b>M-.TN....0.40</b>	<b>LG350</b> <b>L-.TN....0.25</b>	<b>LG350</b> <b>L-.TN....0.32</b>	<b>LG350</b> <b>L-.TN....0.40</b>
Puissance mini. maxi.	min.- max. kW	115 - 330					
Combustible		Gaz naturel			G.P.L.		
Catégorie		(voir paragraphe suivant)			I <sub>3B/P</sub>		
Débit gaz mini.- maxi.	min.- max. (Stm <sup>3</sup> /h)	12 – 35			4 – 13		
Pression gaz mini.* - maxi.	min.- max. mbar	(voir la note 2) - 360					
Alimentation électrique		110 / 120 / 220 / 230V - 50 / 60 Hz					
Puissance électrique	kW	0,67					
Moteur ventilateur (2800t/m)	kW	0,37					
Protection		IP40					
Poids	kg	47					
Diamètre des vannes / Raccordements gaz		1" / Rp 1	1" ¼ / Rp 1 ¼	1" ½ / Rp 1 ½	1" / Rp1	1" ¼ / Rp 1 ¼	1" ½ / Rp 1 ½
Type de réglage		une allure					
Température de fonctionnement	°C	-10 ÷ +50					
Température de stockage	°C	-20 ÷ +60					
Type de service*		intermittent					

<b>BRÛLEURS DEUX ALLURES</b> <b>PROGRESSIFS ET MODULANTS</b>		<b>NG350</b> <b>M-.xx...0.25</b>	<b>NG350</b> <b>M-.xx...0.32</b>	<b>NG350</b> <b>M-.xx...0.40</b>	<b>LG350</b> <b>L-.xx...0.25</b>	<b>LG350</b> <b>L-.xx...0.32</b>	<b>LG350</b> <b>L-.xx...0.40</b>
Puissance mini. kW	min.- max. kW	80 - 330			85 - 330		
Combustible		Gaz naturel			G.P.L.		
Catégorie		(voir paragraphe suivant)			I <sub>3B/P</sub>	I <sub>3B/P</sub>	I <sub>3B/P</sub>
Débit gaz mini.- maxi.	min.- max. (Stm <sup>3</sup> /h)	8.5 – 35	8.5 – 35	8.5 – 35	3 – 13	3 – 13	3 – 13
Pression gaz mini.* - maxi.	min.- max. mbar	(voir la note 2) - 360					
Alimentation électrique		110 / 120 / 220 / 230V - 50 / 60 Hz					
Puissance électrique	kW	0,67					
Moteur ventilateur (2800t/m)	kW	0,37					
Protection		IP40					
Poids	kg	47					
Diamètre des vannes / Raccordements gaz		1" / Rp 1	1" ¼ / Rp 1 ¼	1" ½ / Rp 1 ½	1" / Rp1	1" ¼ / Rp 1 ¼	1" ½ / Rp 1 ½
Type de réglage		Progressives Modulants					
Température de fonctionnement	°C	-10 ÷ +50					
Température de stockage	°C	-20 ÷ +60					
Type de service*		intermittent					

<b>BRÛLEURS DEUX ALLURES</b> <b>PROGRESSIFS ET MODULANTS</b>		<b>NG400</b> <b>M-.TN....0.25</b>	<b>NG400</b> <b>M-.TN....0.32</b>	<b>NG400</b> <b>M-.TN....0.40</b>	<b>NG400</b> <b>M-.TN....0.50</b>
Puissance	min.- max. kW	185 - 420			
Combustible		Gaz naturel			
Catégorie		(voir paragraphe suivant)			
Débit gaz mini.- maxi.	min.- max. (Stm <sup>3</sup> /h)	20 - 44.5			
Pression gaz mini.* - maxi.	min.- max. mbar	(voir la note 2) - 360			
Alimentation électrique		110 / 120 / 220 / 230V - 50 / 60 Hz			
Puissance électrique	kW	0,67			
Moteur ventilateur (2800t/m)	kW	0,37			
Protection		IP40			
Poids	kg	47			
Diamètre des vannes / Raccordements gaz		1" / Rp 1	1" ¼ / Rp 1 ¼	1" ½ / Rp 1 ½	2" / Rp 2
Type de réglage		une allure			
Température de fonctionnement	°C	-10 ÷ +50			
Température de stockage	°C	-20 ÷ +60			
Type de service*		intermittent			

		<b>NG400 M-xx...0.25</b>	<b>NG400 M-xx...0.32</b>	<b>NG400 M-xx...0.40</b>	<b>NG400 M-xx...0.50</b>
Puissance	min.- max. kW	115 - 420			
Combustible		Gaz naturel			
Catégorie		(voir paragraphe suivant)			
Débit gaz mini.- maxi.	min.- max. (Stm <sup>3</sup> /h)	12 - 44.5			
Pression gaz mini.* - maxi.	min.- max. mbar	(voir la note 2) - 360			
Alimentation électrique		110 / 120 / 220 / 230V - 50 / 60 Hz			
Puissance électrique	kW	0,67			
Moteur ventilateur (2800t/m)	kW	0,37			
Protection		IP40			
Poids	kg	47			
Diamètre des vannes / Raccordements gaz		1" / Rp 1	1" ¼ / Rp 1 ¼	1" ½ / Rp 1" ½	2" / Rp 2
Type de réglage		Progressives Modulants			
Température de fonctionnement	°C	-10 ÷ +50			
Température de stockage	°C	-20 ÷ +60			
Type de service*		intermittent			

<b>BRÛLEURS DEUX ALLURES PROGRESSIFS ET MODULANTS</b>		<b>LG400 L-xx...0.25</b>	<b>LG400 L-xx...0.32</b>	<b>LG400 L-xx...0.40</b>	<b>LG400 L-xx...0.50</b>
Puissance	min.- max. kW	105 - 420			
Combustible		G.P.L.			
Catégorie		I <sub>3B/P</sub>			
Débit gaz mini.- maxi.	min.- max. (Stm <sup>3</sup> /h)	4 - 16			
Pression gaz mini.* - maxi.	min.- max. mbar	(voir la note 2) - 360			
Alimentation électrique		110 / 120 / 220 / 230V - 50 / 60 Hz			
Puissance électrique	kW	0,67			
Moteur ventilateur (2800t/m)	kW	0,37			
Protection		IP40			
Poids	kg	47			
Diamètre des vannes / Raccordements gaz		1" / Rp 1	1" ¼ / Rp 1 ¼	1" ½ / Rp 1" ½	2" / Rp 2
Type de réglage		Progressives Modulants			
Température de fonctionnement	°C	-10 ÷ +50			
Température de stockage	°C	-20 ÷ +60			
Type de service*		intermittent			

## Brûleurs à NOx bas

BRÛLEURS UNE ALLURE		NGX280 M-.TN...0.25	NGX280 M-.TN...0.32	NGX280 M-.TN...0.40
Puissance	min.- max. kWmini. kW	93 - 190		
Combustible		Gaz naturel		
Catégorie		(voir paragraphe suivant)		
Débit gaz mini.- maxi.	min.- max. (Stm <sup>3</sup> /h)	9,8 - 20		
	min.- max. mbar	(voir la note 2) - 360		
Alimentation électrique		110 / 120 / 220 / 230V - 50 / 60 Hz		
Puissance électrique	kW	0,55		
Moteur ventilateur (2800t/m)	kW	0,25		
Protection		IP40		
Poids	kg	47		
Diamètre des vannes / Raccordements gaz		1" / Rp1	1" <sub>1/4</sub> / Rp 1 <sub>1/4</sub>	1" <sub>1/2</sub> / Rp 1 <sub>1/2</sub>
Type de réglage		2-allure		
Température de fonctionnement	°C	-10 ÷ +50		
Température de stockage	°C	-20 ÷ +60		
Type de service*		intermittent		

		NGX280 M-.xx...0.25	NGX280 M-.xx...0.32	NGX280 M-.xx...0.40
Puissance	min.- max. kWmini. kW	60 - 190		
Combustible		Gaz naturel		
Catégorie		(voir paragraphe suivant)		
Débit gaz mini.- maxi.	min.- max. (Stm <sup>3</sup> /h)	6,4 - 20		
Pression gaz mini.* - maxi.	min.- max. mbar	(voir la note 2) - 360		
Alimentation électrique		110 / 120 / 220 / 230V - 50 / 60 Hz		
Puissance électrique	kW	0,55		
	kW	0,25		
Protection		IP40		
Poids	kg	47		
Diamètre des vannes / Raccordements gaz		1" / Rp1	1" <sub>1/4</sub> / Rp 1 <sub>1/4</sub>	1" <sub>1/2</sub> / Rp 1 <sub>1/2</sub>
Type de réglage		Progressives Modulants		
Température de fonctionnement	°C	-10 ÷ +50		
Température de stockage	°C	-20 ÷ +60		
Type de service*		intermittent		

BRÛLEURS DEUX ALLURES PROGRESSIFS ET MODULANTS		NGX350 M-.xx...0.25	NGX350 M-.xx...0.32	NGX350 M-.xx...0.40
Puissance	min.- max. kW	65 - 260		
Combustible		Gaz naturel		
Catégorie		(voir paragraphe suivant)		
Débit gaz mini.- maxi.	min.- max. (Stm <sup>3</sup> /h)	7 - 27.5		
Pression gaz mini.* - maxi.	min.- max. mbar	(voir la note 2) - 360		
Alimentation électrique		110 / 120 / 220 / 230V - 50 / 60 Hz		
Puissance électrique	kW	0,67		
Moteur ventilateur (2800t/m)	kW	0,37		
Protection		IP40		
Poids	kg	47		
Diamètre des vannes / Raccordements gaz		1" / Rp1	1" <sub>1/4</sub> / Rp 1 <sub>1/4</sub>	1" <sub>1/2</sub> / Rp 1 <sub>1/2</sub>
Type de réglage		Progressives Modulants		
Température de fonctionnement	°C	-10 ÷ +50		
Température de stockage	°C	-20 ÷ +60		
Type de service*		intermittent		

BRÛLEURS DEUX ALLURES PROGRESSIFS ET MODULANTS		NGX400 M-.xx...0.25	NGX400 M-.xx...0.32	NGX400 M-.xx...0.40	NGX400 M-.xx...0.50
Puissance	min.- max. kW	90 - 350			
Combustible		Gaz naturel			
Catégorie		(voir paragraphe suivant)			
Débit gaz mini.- maxi.	min.- max. (Stm <sup>3</sup> /h)	9.5 - 37			
Pression gaz mini.* - maxi.	min.- max. mbar	(voir la note 2) - 360			
Alimentation électrique		110 / 120 / 220 / 230V - 50 / 60 Hz			
Puissance électrique	kW	0,67			
Moteur ventilateur (2800t/m)	kW	0,37			
Protection		IP40			
Poids	kg	47			
Diamètre des vannes / Raccordements gaz		1" / Rp 1	1" ¼ / Rp 1 ¼	1" ½ / Rp 1 ½	2" / Rp 2
Type de réglage		Progressives Modulants			
Température de fonctionnement	°C	-10 ÷ +50			
Température de stockage	°C	-20 ÷ +60			
Type de service*		intermittent			

Note: tous les débits gaz (Stm<sup>3</sup>/h) se réfèrent à des conditions standard: pression 1013 mbar et température de 15°C.

Les débits gaz se réfèrent au gaz naturel G20 (pouvoir calorifique inférieur PCI, 34.02 MJ/Stm<sup>3</sup>); en cas d'exploitation au gaz naturel G25 (pouvoir calorifique inférieur PCI, 29.25 MJ/Stm<sup>3</sup>), les débits doivent être multipliés par un facteur de 1.16.

\* Pression minimale afin d'obtenir le débit maximal avec n'importe quelle contre-pression dans la chambre de combustion prévue dans la plage de travail spécifique. Le brûleur fonctionne correctement même à des pressions plus basses à condition qu'elles soient suffisantes à garantir le débit gaz nécessaire.

\* **NOTE SUR LE TYPE DE SERVICE DU BRÛLEUR:** l'équipement de contrôle de flamme s'arrête automatiquement après 24 heures heures de fonctionnement continu. L'appareil redémarre toujours automatiquement et immédiatement.

### Catégories gaz et pays d'application

CATÉGORIE GAZ	PAIS
I <sub>2H</sub>	AT, ES, GR, SE, FI, IE, HU, IS, NO, CZ, DK, GB, IT, PT, CY, EE, LV, SI, MT, SK, BG, LT, RO, TR, CH
I <sub>2E</sub>	LU, PL
I <sub>2E(R)B</sub>	BE
I <sub>2EK</sub>	NL
I <sub>2ELL</sub>	DE
I <sub>2Er</sub>	FR

### Comment interpréter la « plage de travail » du brûleur

Pour vérifier si le brûleur est approprié au générateur de chaleur sur lequel il doit être monté, il faut avoir les paramètres suivants:

Puissance au foyer de la chaudière en kW ou kcal/h ( $\text{kW} = \text{kcal/h}/860$ );

Pression dans la chambre de combustion, appelée également perte de charge ( $D_p$ ) côté fumées (cette donnée est à rechercher sur la plaquette de l'appareil ou sur le manuel du générateur de chaleur).

Exemple:

Puissance au foyer du générateur: 600 kW

Pression dans la chambre de combustion: 4 mbar

Tracer, sur le diagramme « Plage de travail » du brûleur (Fig. 2), une droite verticale à la hauteur de la puissance au foyer et une droite horizontale à la hauteur de la valeur de la pression désirée.

Le brûleur n'est approprié que si le point d'intersection A des deux droites se trouve à l'intérieur de la plage de travail. Les données se réfèrent aux conditions standard : pression atmosphérique de 1013 mbar, température ambiante de 15°.

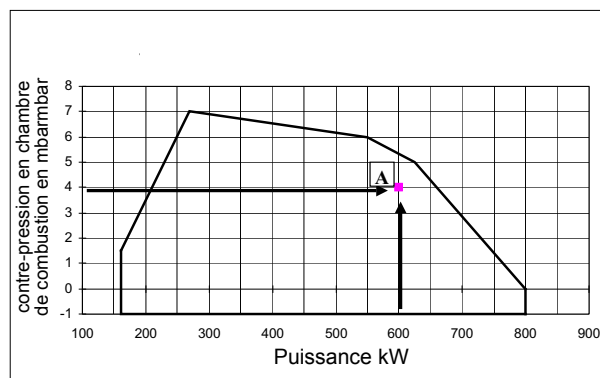

### Vérification du diamètre correct de la rampe gaz

Pour vérifier si le diamètre de la rampe gaz est correct, il est nécessaire de connaître la pression du gaz disponible en amont des vannes gaz du brûleur. Il faut donc soustraire la pression dans la chambre de combustion à cette pression. Le résultat obtenu sera appelé  $p_{\text{gaz}}$ . Tracer maintenant une droite verticale à la hauteur de la valeur de puissance du générateur de chaleur (dans l'exemple, 600 kW), reportée sur l'abscisse, jusqu'à ce qu'elle croise la courbe de pression du réseau correspondant au diamètre de la rampe montée sur le brûleur en examen (DN65, dans l'exemple). Tracer une droite horizontale à partir du point d'intersection jusqu'à ce qu'elle croise, sur l'ordonnée, la valeur de pression nécessaire à développer la puissance requise par le générateur. La valeur lue devra être égale ou inférieure à la valeur  $p_{\text{gaz}}$ , calculée précédemment.

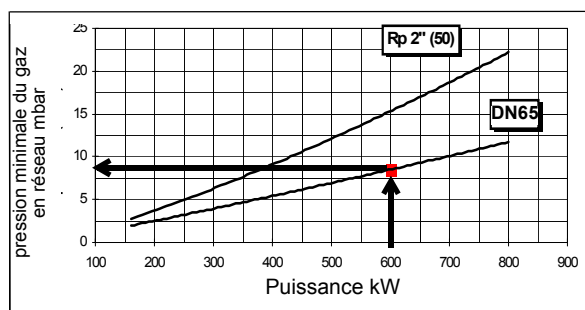

## PLAGES DE TRAVAIL

### Brûleurs à Gaz Naturel

CONTRE-PRESSION EN CHAMBRE DE COMBUSTION mbar

**NG280 Une allure**

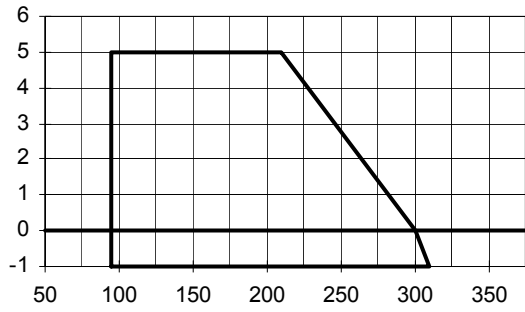

**NG280 2-allures**

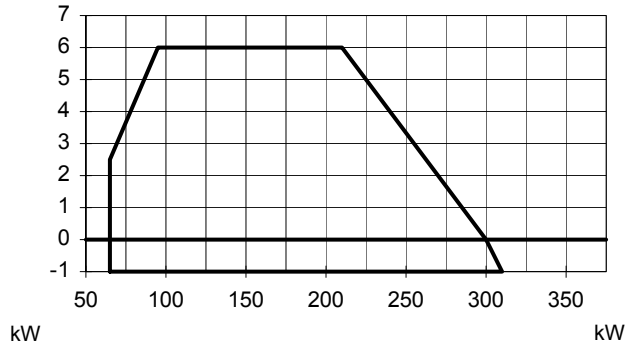

**NG350 Une allure**

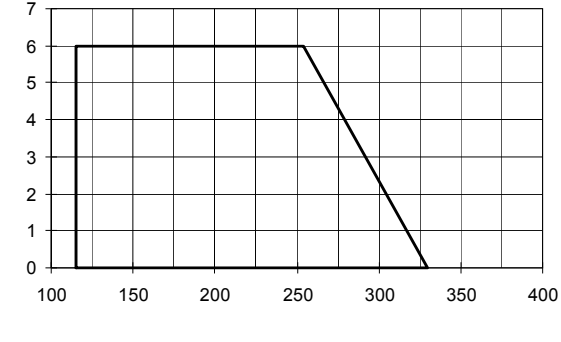

**NG350 Progressiv**

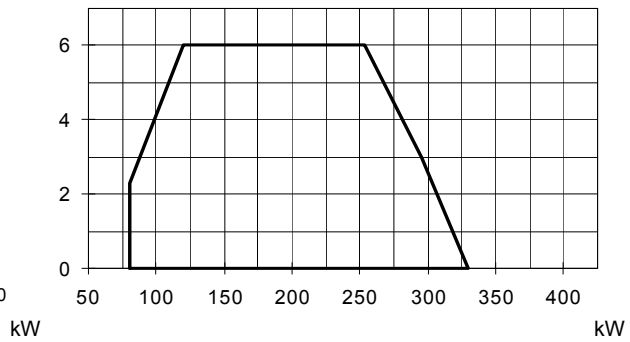

**NG400 Une allure**

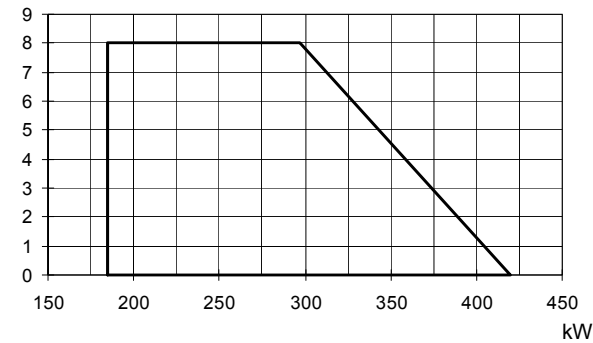

**NG400 Progressiv**

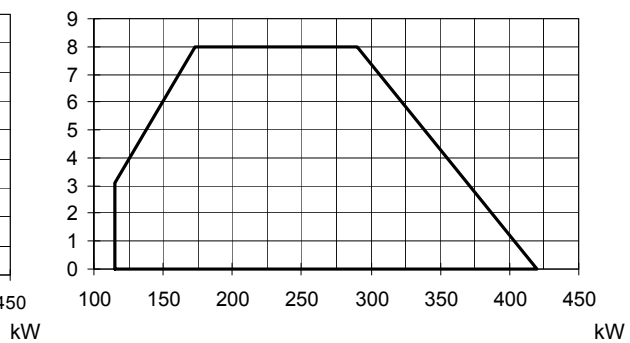

### ● BRÛLEURS G.P.L.

CONTRE-PRESSION EN CHAMBRE DE COMBUSTION mbar

**LG280 Une allure**

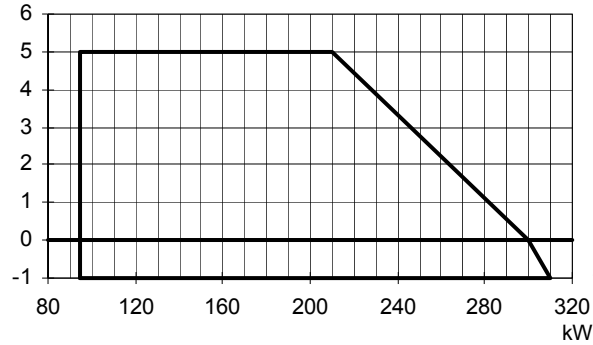

**LG280 Progressiv**



CONTRE-PRESSION EN CHAMBRE  
DE COMBUSTION

LG350 Une allure

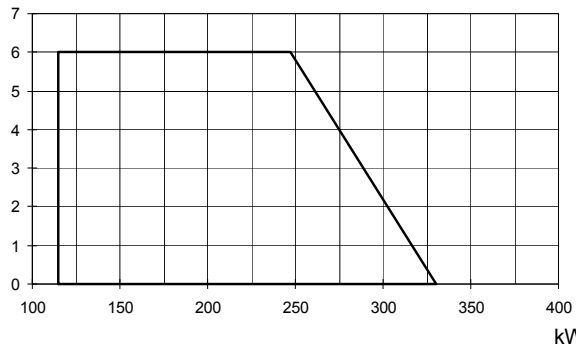

LG350 Progressiv

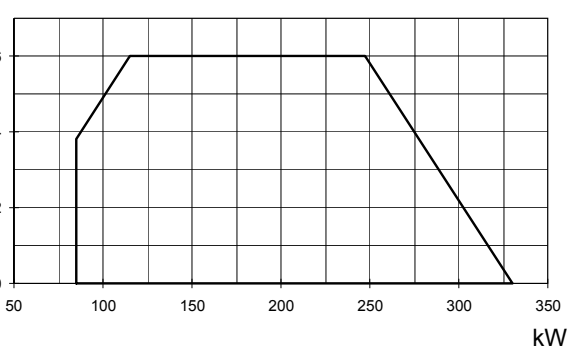

LG400 Une allure

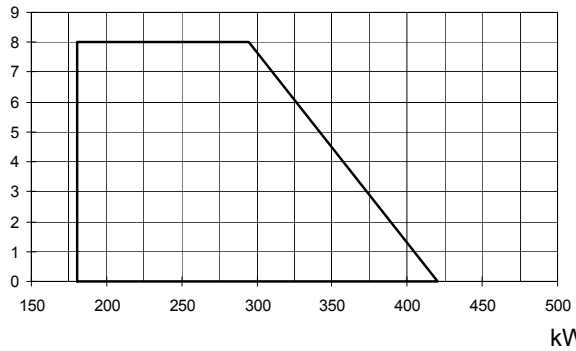

LG400 Progressiv

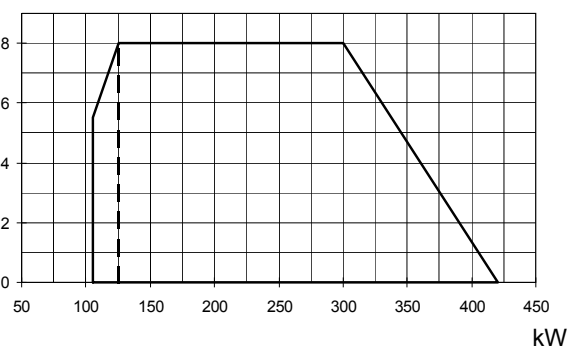

● Brûleurs à NOx bas

CONTRE-PRESSION EN CHAMBRE  
DE COMBUSTION

NGX280 Progressiv

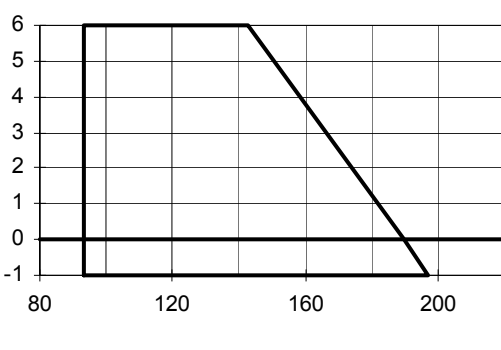

NGX280 Progressiv

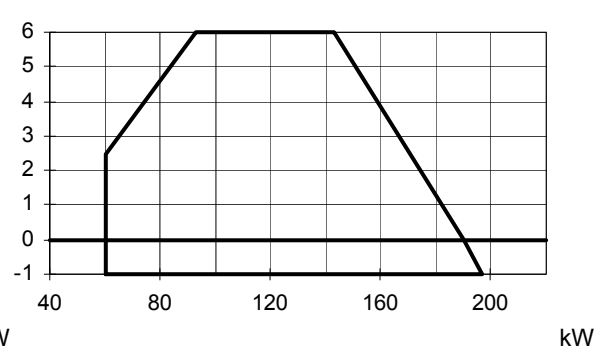

NGX350 Progressiv

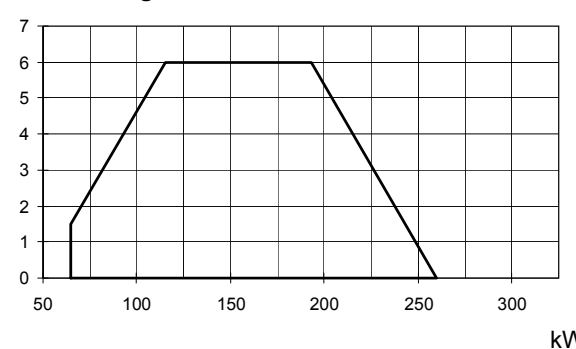

NGX400 Progressiv



**AVERTISSEMENT:** La plage de travail est un diagramme qui représente les performances obtenues lors de l'homologation ou des tests de laboratoire mais ne représentent pas la plage de réglage de la machine. On obtient généralement le point de puissance maximale de ce diagramme en mettant la tête de combustion sur la position «max.» (voir paragraphe «Réglage de la tête de combustion»); on obtient au contraire le point de puissance minimale en mettant la tête sur la position «min». Vu que la tête est positionnée une fois pour toutes au cours du premier allumage de façon à trouver le juste compromis entre la puissance brûlée et les caractéristiques du générateur, il n'est pas dit que la puissance minimale d'utilisation soit la puissance minimale lue sur la plage de travail.

## COURBES DE PRESSION DU DÉBIT EN RÉSEAU

Brûleurs à Gaz Naturel

NG280 M-.TN...

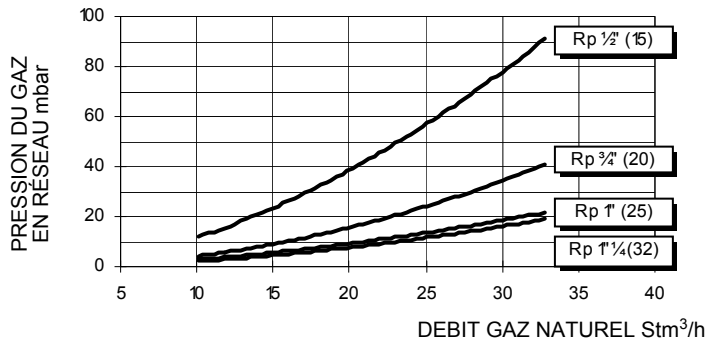

NG280 M-.xx...

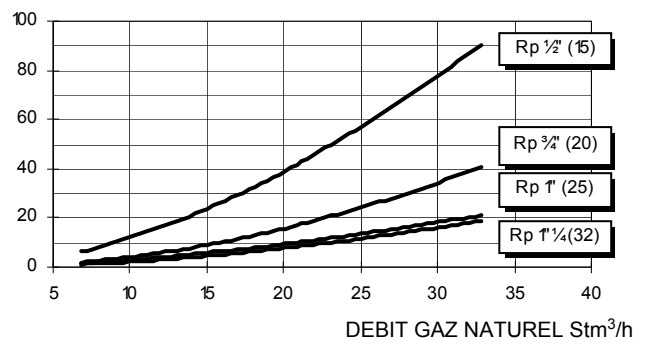

NG350 M-.TN...

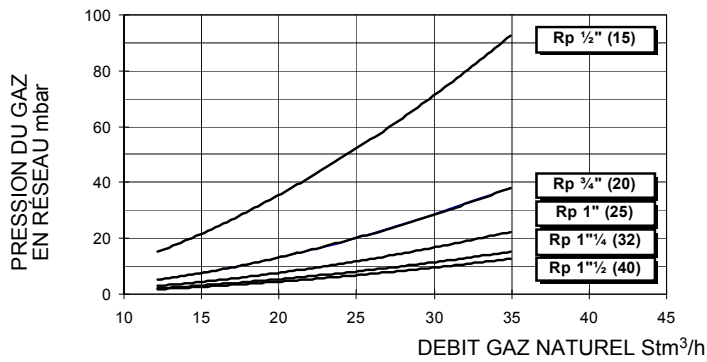

NG350 M-.PR/MD...

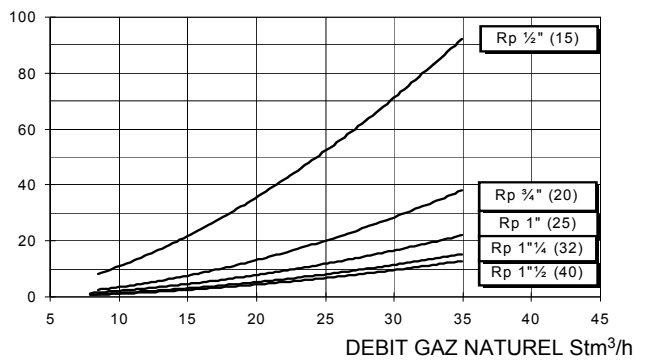

NG400 M-.TN..15-20-25

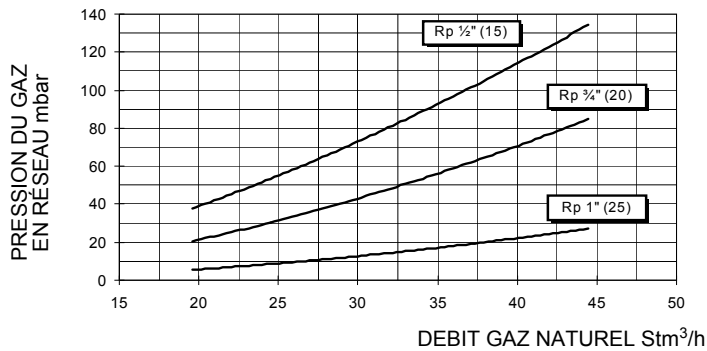

NG400 M-.TN..32-40-50

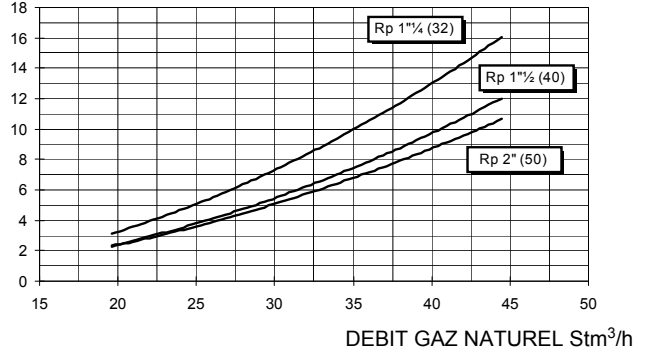

NG400 M-.PR/MD...15-20-25

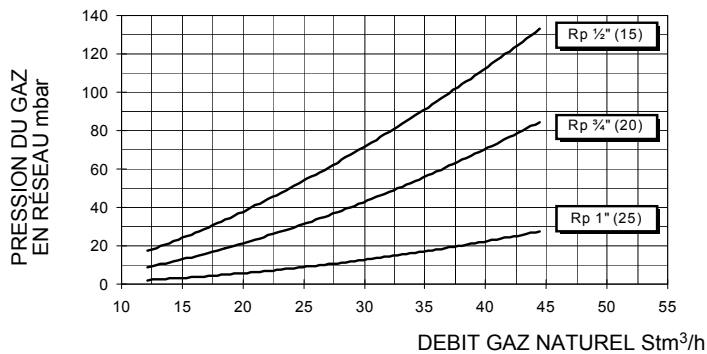

NG400 M-.PR/MD...32-40-50

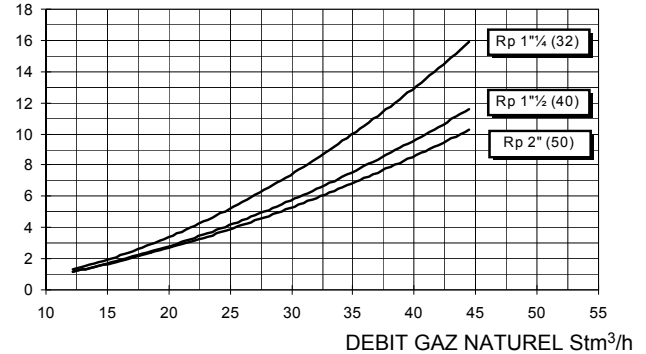

## ● BRÛLEURS G.P.L.

LG280 L-.TN...

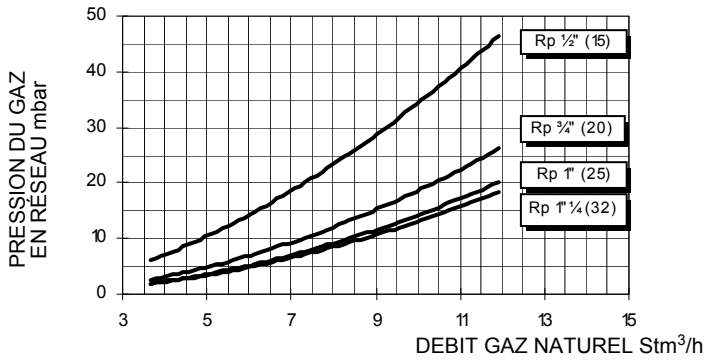

LG280 L-.xx...

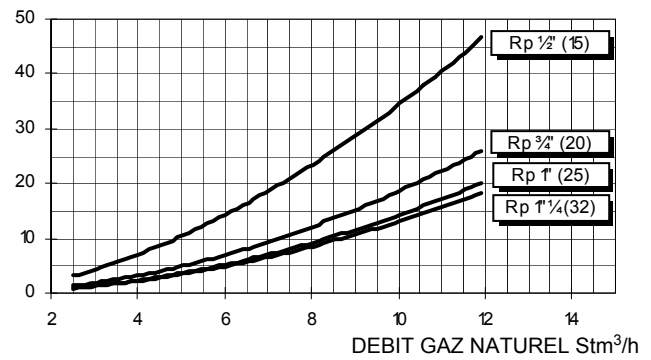

LG350 L-.TN...

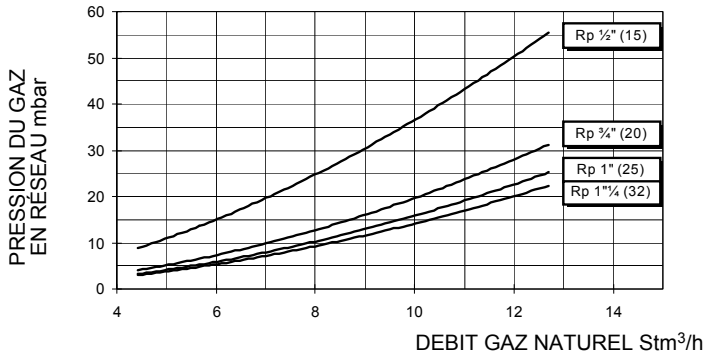

LG350 L-.PR/MD....

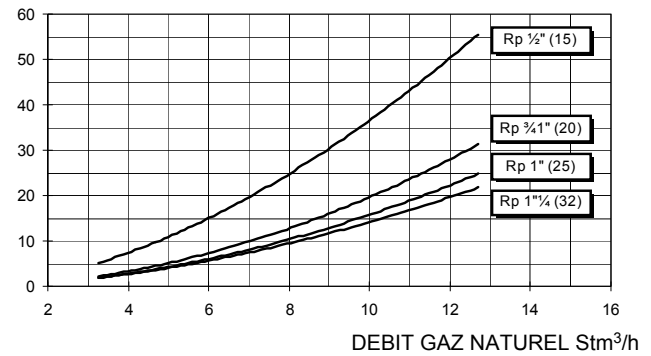

LG400 L-.TN...

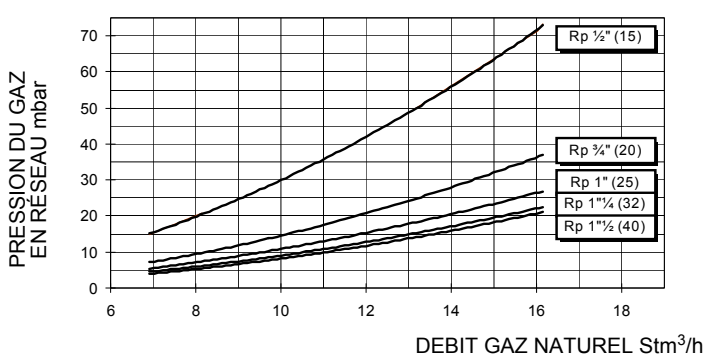

LG400 L-.PR/MD....

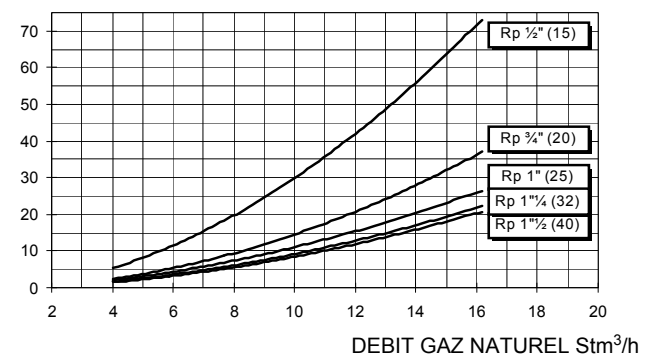

Les valeurs indiquées dans les diagrammes se rapportent au **gaz naturel** ayant un pouvoir calorifique de 8125 kcal/Stm<sup>3</sup> (15°C, 1013 mbar) et une densité de 0,714 kg/Stm<sup>3</sup>. Lorsque le pouvoir calorifique et la densité varient, les valeurs de pression doivent être corrigées en conséquence.



Les valeurs indiquées dans les diagrammes se réfèrent à **Gaz propane** ayant un pouvoir calorifique de 22300 kcal/Stm<sup>3</sup> (15°C, 1013 mbar) et une densité de 2,14 kg/Stm<sup>3</sup>. Lorsque le pouvoir calorifique et la densité varient, les valeurs de pression doivent être corrigées en conséquence.

Où:

$$\Delta p_2 = \Delta p_1 * \left( \frac{Q_2}{Q_1} \right)^2 * \left( \frac{\rho_2}{\rho_1} \right)$$

- $p_1$  Pression du gaz naturel indiquée dans le diagramme
- $p_2$  Pression du gaz réel
- $Q_1$  Débit de gaz naturel indiqué dans le diagramme
- $Q_2$  Débit de gaz réel
- $\rho_1$  Densité du gaz naturel illustrée dans le diagramme
- $\rho_2$  Densité gaz réel

● Brûleurs à NOx bas

NGX280 M-.TN.. Progressiv

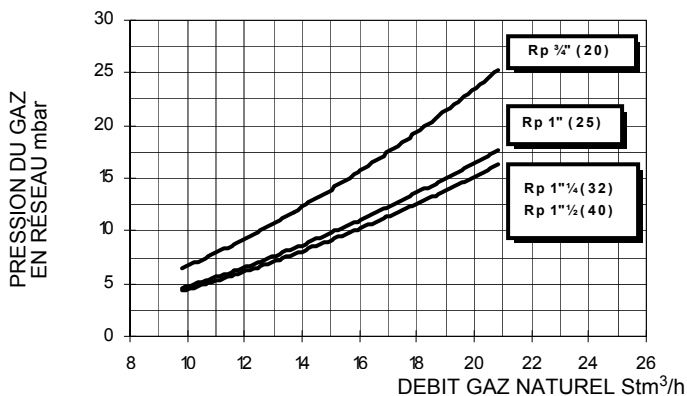

NGX280 M-.xx..Progressiv

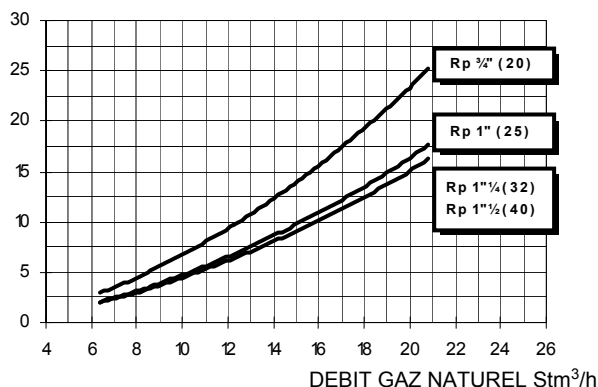

NGX350 Progressiv

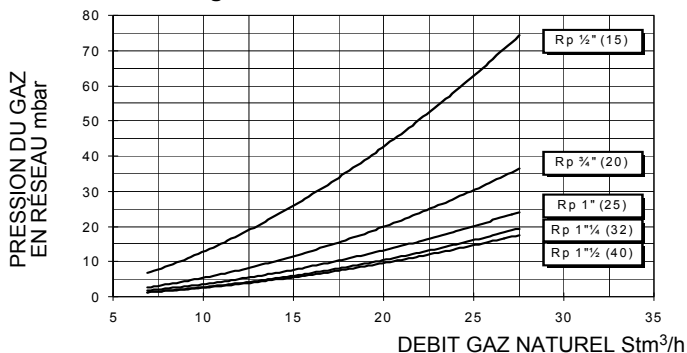

NGX400 M-...15-20-25

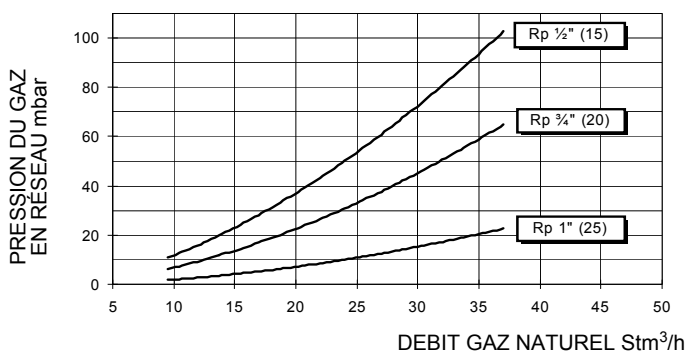

NGX400 M-...32-40-50

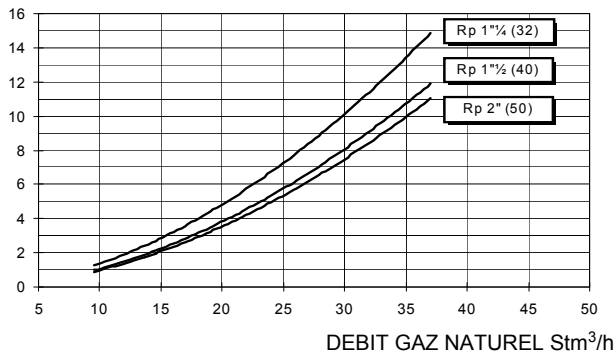

**Attention :** en abscisse se trouve la valeur du débit de gaz, en ordonnée la valeur correspondante de pression du réseau de distribution moins la pression dans la chambre de combustion. Pour connaître la pression minimum à l'entrée de la rampe, nécessaire pour obtenir le débit de gaz demandé, il faut additionner la pression dans la chambre de combustion à la valeur lue en ordonnée



Les valeurs indiquées dans les diagrammes se rapportent au **gaz naturel** ayant un pouvoir calorifique de 8125 kcal/Stm<sup>3</sup> (15°C, 1013 mbar) et une densité de 0,714 kg/Stm<sup>3</sup>. Lorsque le pouvoir calorifique et la densité varient, les valeurs de pression doivent être corrigées en conséquence.



Les valeurs indiquées dans les diagrammes se réfèrent à **Gaz propane** ayant un pouvoir calorifique de 22300 kcal/Stm<sup>3</sup> (15°C, 1013 mbar) et une densité de 2,14 kg/Stm<sup>3</sup>. Lorsque le pouvoir calorifique et la densité varient, les valeurs de pression doivent être corrigées en conséquence.

Où:

$$\Delta p_2 = \Delta p_1 * \left(\frac{Q_2}{Q_1}\right)^2 * \left(\frac{\rho_2}{\rho_1}\right)$$

- p 1 Pression du gaz naturel indiquée dans le diagramme
- p 2 Pression du gaz réel
- Q 1 Débit de gaz naturel indiqué dans le diagramme
- Q 2 Debit de gaz réel
- ρ 1 Densité du gaz naturel illustrée dans le diagramme
- ρ 2 Densité gaz réel

## Courbes de pression dans la tête de combustion en fonction du débit du gaz

Les courbes se réfèrent à une pression de 0 mbar dans la chambre de combustion!

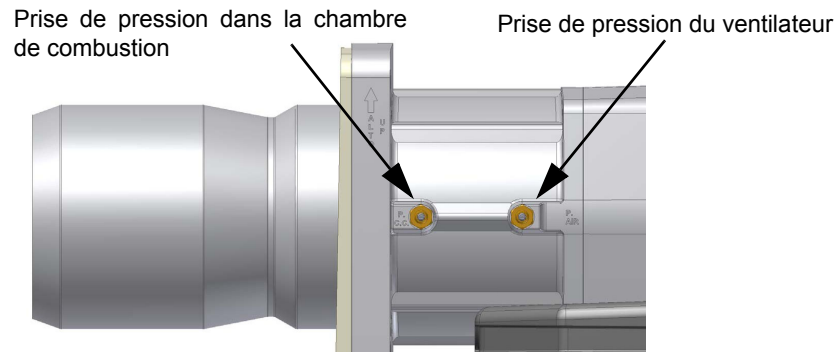

Les courbes de pression dans la tête de combustion en fonction du débit du gaz sont valables si le brûleur est réglé correctement (pourcentage de O<sub>2</sub> résiduel dans les fumées comme d'après le tableau «Paramètres de combustion conseillés» et CO dans les limites imposées par la norme). La tête de combustion, la vanne papillon et la servocommande sont alors entièrement ouvertes. Se référer à la , qui indique la façon correcte de mesurer la pression du gaz, en tenant compte des valeurs de pression dans la chambre de combustion, relevées par le manomètre, ou des caractéristiques techniques de la chaudière/ utilisation.

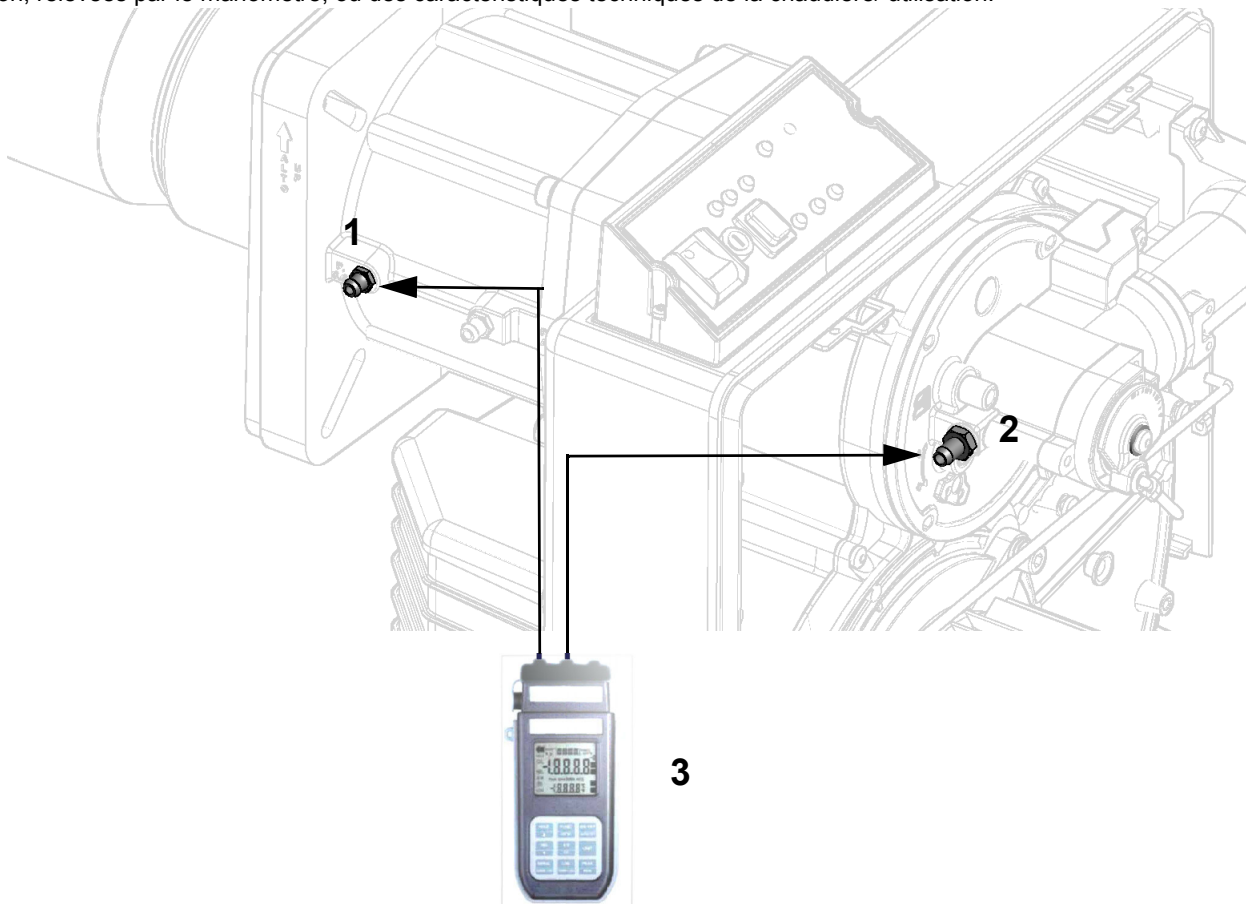

Fig. 1

### Légende

- 1 Prise de pression dans la chambre de combustion
- 2 Prise de pression gaz vanne papillon
- 3 Manomètre différentiel

Sur la base de la pression différentielle ainsi mesurée, on obtient la valeur du débit maximal de gaz brûlé, en utilisant les graphiques du paragraphe suivant. En entrant la valeur de la pression mesurée en ordonnée, la valeur du débit est lue en abscisse (Stm<sup>3</sup>/h)

**NOTE:** LES COURBES PRESSION - DEBIT SONT PRESENTES A TITRE INDICATIF; POUR UN REGLAGE CORRECT DU DEBIT DU GAZ FAIRE REFERENCE AU COMPTEUR HORAIRE.

## Courbes pression dans la tête de combustion – débit du gaz

- Brûleurs au gaz naturel

**NG280 -**

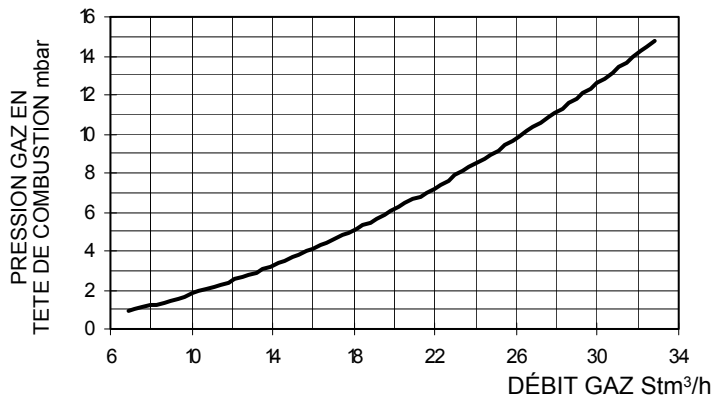

**NG350 -**

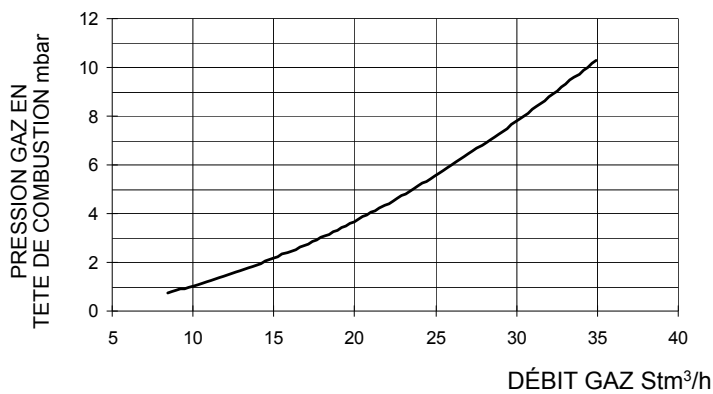

**NG400 -**



- BRÛLEURS G.P.L.

**LG280 -**

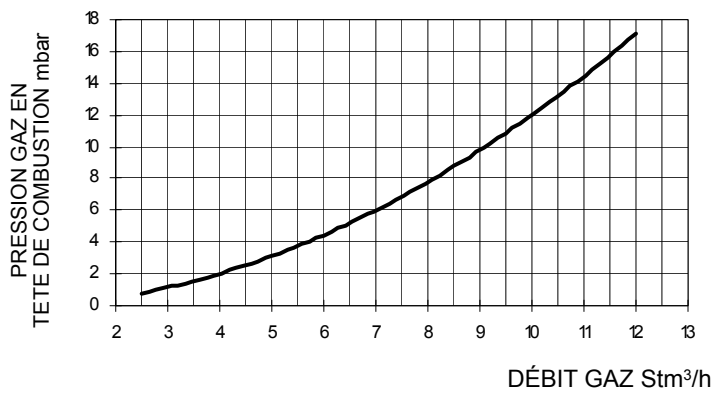

**LG350 -**

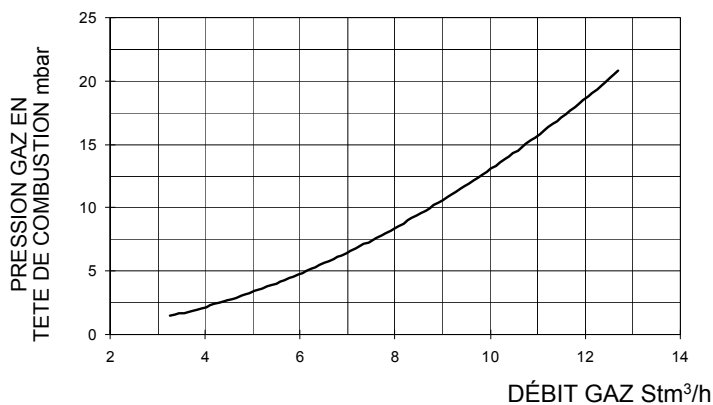

**LG400 -**

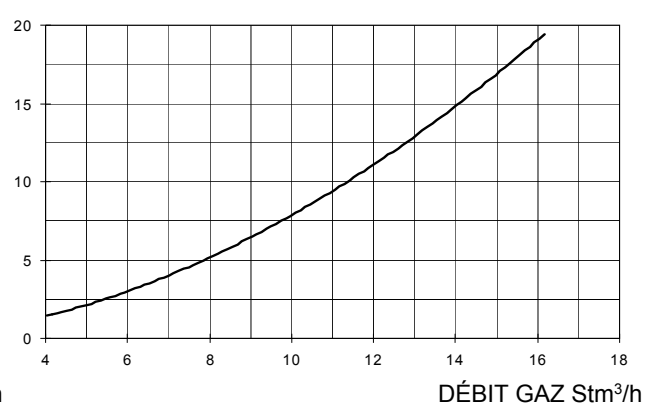

## ● Brûleurs à NOx bas

## NGX280

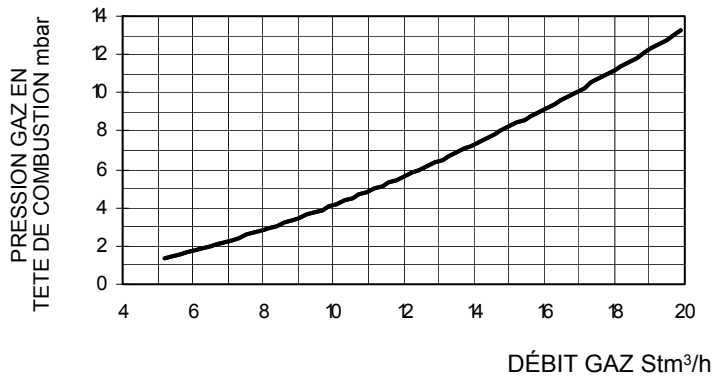

## NGX350



## NGX400

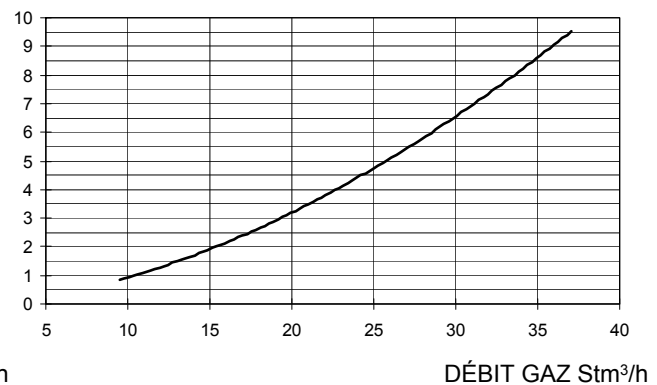

Les valeurs indiquées dans les diagrammes se rapportent au **gaz naturel** ayant un pouvoir calorifique de 8125 kcal/Stm<sup>3</sup> (15°C, 1013 mbar) et une densité de 0,714 kg/Stm<sup>3</sup>. Lorsque le pouvoir calorifique et la densité varient, les valeurs de pression doivent être corrigées en conséquence.



Les valeurs indiquées dans les diagrammes se réfèrent à **Gaz propane** ayant un pouvoir calorifique de 22300 kcal/Stm<sup>3</sup> (15°C, 1013 mbar) et une densité de 2,14 kg/Stm<sup>3</sup>. Lorsque le pouvoir calorifique et la densité varient, les valeurs de pression doivent être corrigées en conséquence.

Où:

$$\Delta p_2 = \Delta p_1 * \left(\frac{Q_2}{Q_1}\right)^2 * \left(\frac{\rho_2}{\rho_1}\right)$$

$p_1$  Pression du gaz naturel indiquée dans le diagramme  
 $p_2$  Pression du gaz réel  
 $Q_1$  Débit de gaz naturel indiqué dans le diagramme  
 $Q_2$  Débit de gaz réel  
 $\rho_1$  Densité du gaz naturel illustrée dans le diagramme  
 $\rho_2$  Densité gaz réel

## Cotes d'encombrement en mm

- *Brûleurs standard*

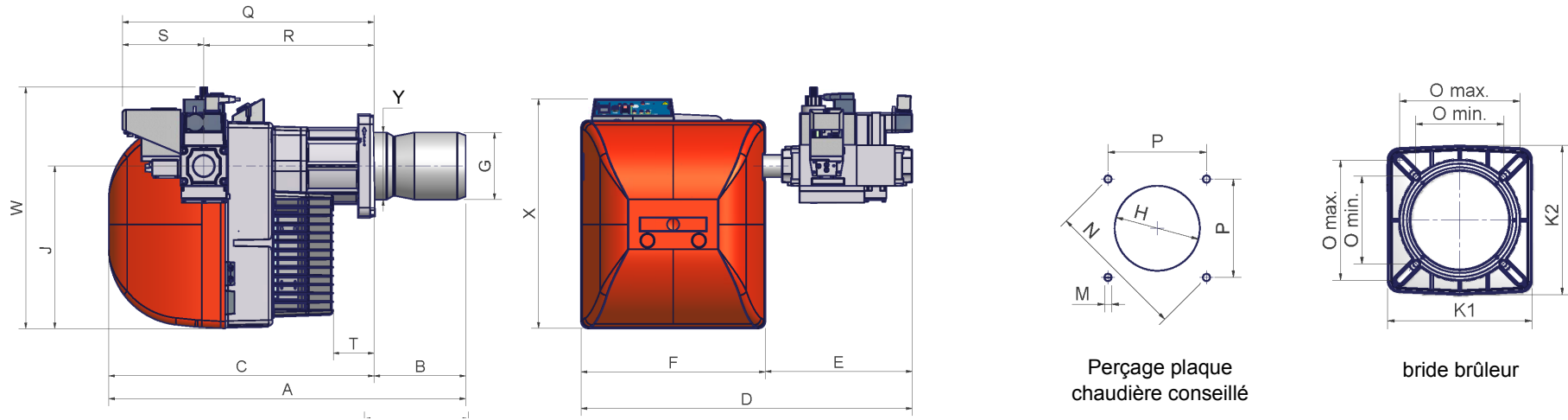

	A(S*)	A(L)*	B(S*)	B(L)*	C	F	G	H	J	K1	K2	M	N	Omin	Omax	P	Q	R	S	T	X	Y
<b>NG/LG280</b>	733	878	163	308	570	396	117	137	348	215	223	M10	219	131	172	155	541	366	175	128	491	130
<b>NG/LG350</b>	748	878	178	308	570	396	125	164	348	215	223	M10	219	131	172	155	541	366	175	89	491	144
<b>NG/LG400</b>	768	898	198	328	570	396	144	164	348	215	223	M10	219	131	172	155	541	366	175	89	491	144

\* S = Tête standard

L = Tête long

	D ± 5 mm				E ± 5 mm				W			
	Rp 1	Rp 1 ¼	Rp 1 ½	Rp 2	Rp 1	Rp 1 ¼	Rp 1 ½	Rp 2	Rp 1	Rp 1 ¼	Rp 1 ½	Rp 2
<b>NG/LG280</b>	596	596	726	726	200	200	330	330	508	508	517	567
<b>NG/LG350</b>	596	596	726	726	200	200	330	330	508	508	517	567
<b>NG/LG400</b>	596	596	726	726	200	200	330	330	508	508	517	567

B\*: Longueurs spéciales d'une bouche vous devez accepter avec **Cib Unigas**

## Cotes d'encombrement en mm

Brûleurs Low NOx

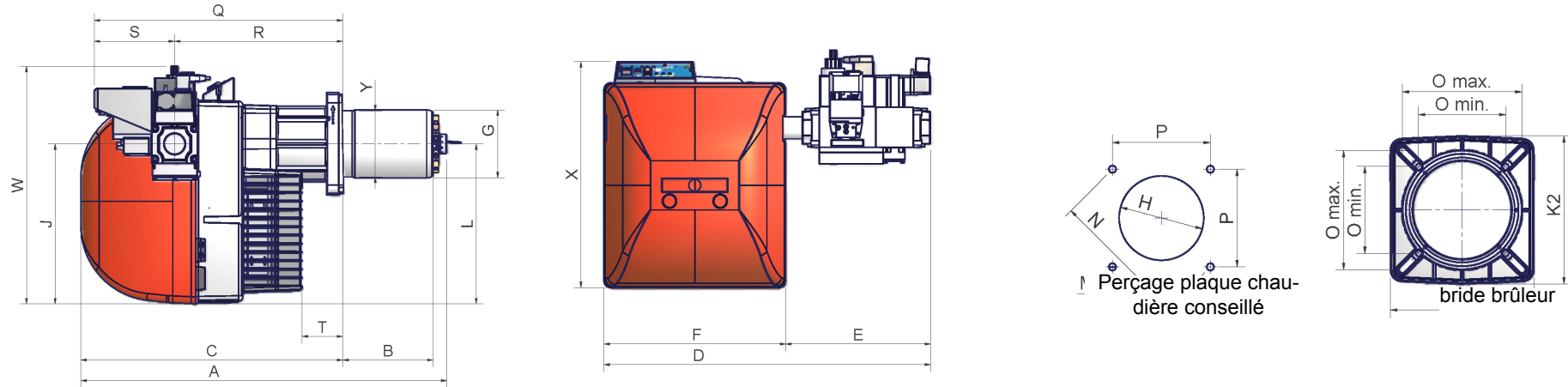

	A(S*)	A(L)*	B(S*)	B(L)*	C	F	G	H	J	K1	K2	M	N	Omin	Omax	P	Q	R	S	T	X	Y
<b>NGX280</b>	733	878	163	308	570	396	114	137	348	215	223	M10	219	131	172	155	541	366	175	128	491	130
<b>NGX350</b>	748	878	178	308	570	396	137	164	348	215	223	M10	219	131	172	155	541	366	175	89	491	144
<b>NGX400</b>	768	898	198	328	570	396	156	176	348	215	223	M10	219	131	172	155	541	366	175	89	491	156

\* S = Tête standard

L = Tête long

	D ± 5 mm				E ± 5 mm				W			
	Rp 1	Rp 1 ¼	Rp 1 ½	Rp 2	Rp 1	Rp 1 ¼	Rp 1 ½	Rp 2	Rp 1	Rp 1 ¼	Rp 1 ½	Rp 2
<b>NGX280</b>	596	596	726	726	200	200	330	330	508	508	517	567
<b>NGX350</b>	596	596	726	726	200	200	330	330	508	508	517	567
<b>NGX400</b>	596	596	726	726	200	200	330	330	508	508	517	567

B\*: Longueurs spéciales d'une bouche vous devez accepter avec **Cib Unigas**

## MONTAGE ET CONNEXION

Les brûleurs sont livrés dans des boîtes en carton de 795mm x 490mm x 550mm (L x P x H).

Ces emballages sont résistants à l'humidité et ne peuvent être empilés au-delà du nombre maximum indiqué à l'extérieur de l'emballage.

A l'intérieur de chaque paquet sont placés :

- brûleur avec rampe à gaz ;
- joint d'étanchéité à placer entre le brûleur et la chaudière ;
- enveloppe contenant ce manuel

Pour éliminer l'emballage du brûleur, suivez les procédures prévues par les lois en vigueur sur l'élimination des matériaux.

### Montage du brûleur à la chaudière

Pour installer le brûleur sur la chaudière, procéder comme suit:

- 1 forer la plaque de fermeture de la chambre de combustion comme décrit au paragraphe "Dimensions d'encombrement";
- 2 approcher le brûleur à la plaque de la chaudière: lever et manutentionner le brûleur en utilisant un chariot élévateur à fourches (voir paragraphe "Levage et manutention");
- 3 placer les 4 goujons selon le gabarit de perçage décrit au paragraphe "Dimensions d'encombrement" en regard du trou sur la porte de la chaudière;
- 4 visser les goujons (5) sur la plaque;
- 5 placer le joint sur la bride du brûleur;
- 6 monter le brûleur sur la chaudière;
- 7 le fixer aux goujons de la chaudière avec les écrous selon le schéma indiqué en figure.
- 8 lorsque le montage du brûleur sur la chaudière est terminé, sceller l'espace entre l'embout et le pisé avec du matériau isolant approprié (cordon en fibre résistant à la température ou ciment réfractaire).

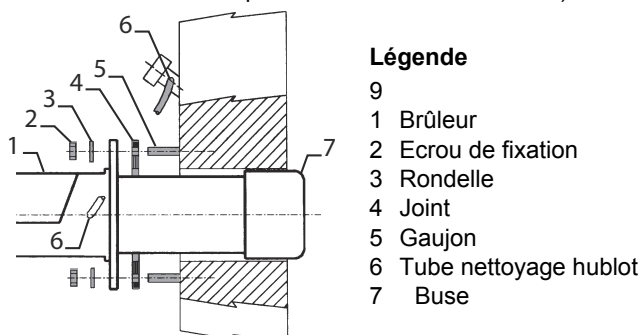

## JOINT DU BRÛLEUR (NGX400)

Pour installer le joint du brûleur, procédez comme indiqué par les images suivantes

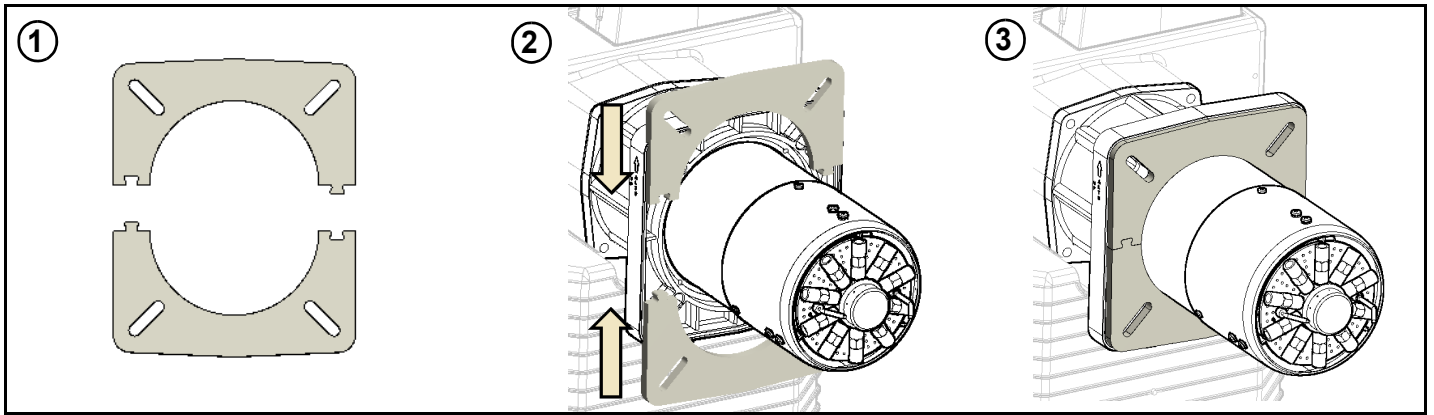

### Accouplement du brûleur à la chaudière

Les brûleurs décrits dans ces instructions ont été essayés dans des chambres de combustion correspondant à la norme EN676, dont les dimensions sont reportées dans le diagramme. En cas d'accouplement du brûleur avec des chaudières dont la chambre de combustion résulte avoir un diamètre mineur ou une longueur inférieure de celle mentionnées dans le diagramme, prière de contacter le constructeur afin de pouvoir vérifier que le brûleur soit convenable à l'installation pour laquelle il est prévu. Afin de correctement coupler le brûleur et la chaudière, vérifier que la puissance demandée et la pression dans la chambre de combustion soient comprises dans la plage de travail. En cas contraire, le choix du brûleur devra être réexaminé avec le constructeur. Le choix de la longueur de la buse doit suivre les consignes du constructeur de la chaudière. Si ces informations manquaient, les suivantes directions seront suivies:

- Chaudières en fonte, chaudière à trois parcours de fumées (avec le premier parcours de fumées dans la partie arrière) la buse doit entrer dans la chambre de combustion sans dépasser les 100 mm.
- La longueur des buses ne répond pas toujours à ce critère et donc il pourrait se présenter la nécessité d'employer une entretoise de la mesure convenable apte à faire reculer le brûleur de façon à satisfaire les mesures sus mentionnées.

Chaudières pressurisées avec inversion de flamme: dans ce cas la buse devra pénétrer en chambre de combustion pour au moins 50 - 100 mm par rapport à la plaque du faisceau tubulaire.

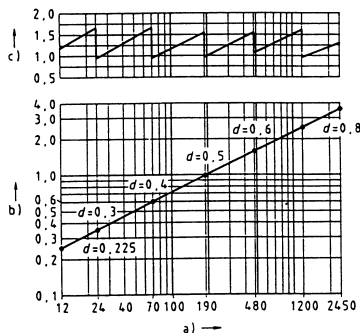

Légende

- Puissance en kW
- Longueur du foyer en mètres
- Charge thermique spécifique du foyer MW/m<sup>3</sup>
- Diamètre du foyer (m)

Fig. 1 - Charge thermique, diamètre et longueur du foyer d'essai en fonction de la puissance brûlée Q.

### (NG/LG350-NG/LG400) Modification de la longueur de bouche

La longueur de l'embout peut être modifiée selon les besoins en suivant les instructions ci-dessous.

- 1 Retirez la tête de combustion (voir le paragraphe "Retrait de la tête de combustion" - Partie III du manuel).
- 2 Retirez la douille à bride T en enlevant les 4 vis Allen VTF
- 3 Retirez les 4 vis qui fixent la buse au corps de la buse.
- 4 Retirez la buse de la collerette et remettez-la en place sur le côté opposé, comme indiqué en , en la fixant avec les vis retirées précédemment.
- 5 Remontez le gicleur sur le brûleur en respectant la référence indiquée.

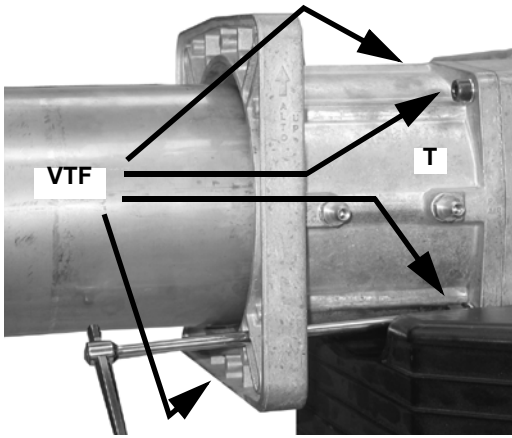

Fig. 2

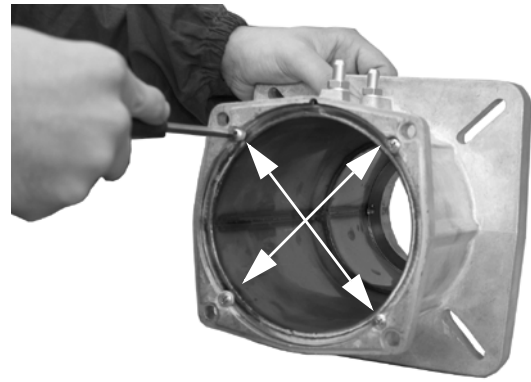

Fig. 3

Fig. 4 - - Bouche version courte

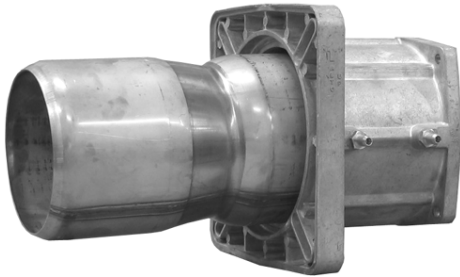

Fig. 5 - Bouche version longue

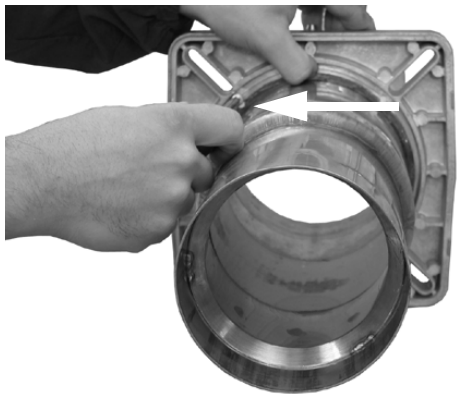
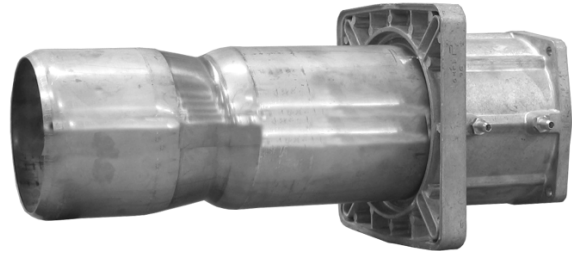

Fig. 6

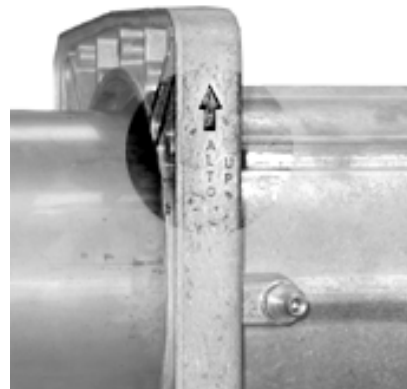
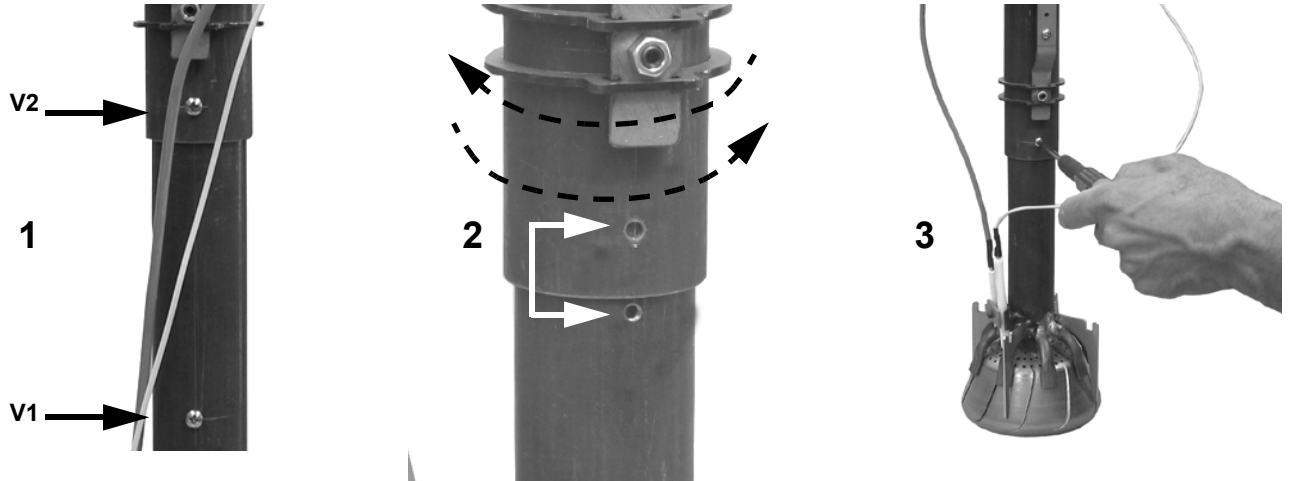

Fig. 7

Si la longueur de la buse est modifiée, la longueur de la tête de combustion doit également être adaptée comme indiqué ci-dessous.

- 1 Retirer les vis V1 et V2
- 2 Abaissez l'extrémité de la tête de combustion, en la déplaçant avec une légère rotation alternée, jusqu'à ce que les trous indiqués coïncident et fixez la vis.
- 3 Tirer les câbles d'allumage et de détection vers l'arrière de la tête de combustion pour ajuster leur longueur, en veillant à ne pas arracher le connecteur de l'électrode de détection.
- 4 Remonter la tête de combustion



### Inversion de la rampe gaz

La connection de la rampe gaz peut être inversé de la droite vers la gauche, en suivant les instructions suivantes..

- 1 Libérer le tirant T et le faire sortir de son siège (tirer vers l'extérieur) .
- 2 Enlever les vis V1, V2, V3, V4, VT1 et VT2 .
- 3 Débrancher le câble d'allumage CA du transformateur d'allumage .
- 4 Débrancher le connecteur CR de la fiche du circuit imprimé.
- 5 Enlever la bride et la tête de combustion dans le même temps .
- 6 Enlever le tronc bridé et l'installer dans la nouvelle position en fixant les vis VT1 et VT2 VT2 .

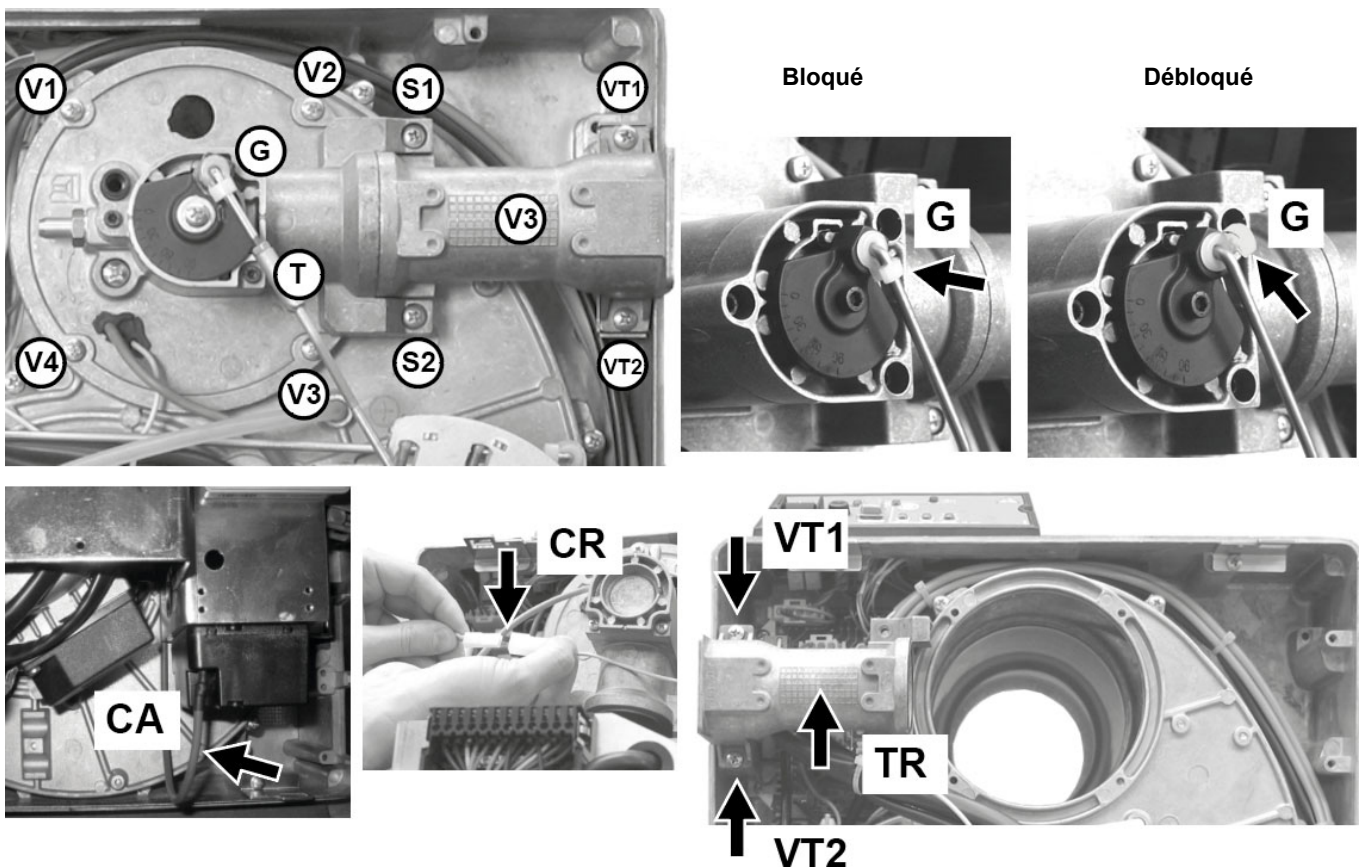

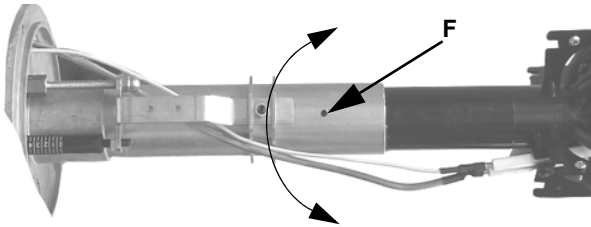

Fig. 8

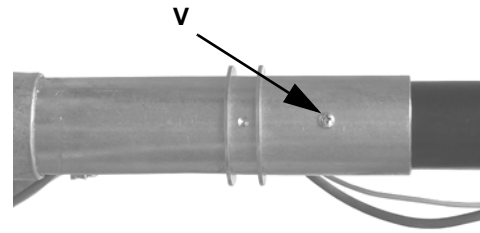

Fig. 9

- 7 Dévisser la vis V qui maintient la tête de combustion au début du tube tête, tourner la tête de 180° comme indiqué en(), jusqu'à rencontrer l'orifice F et fixer de nouveau la vis V.
- 8 ()Enlever la bride et la tête de combustion dans le même temps
- 9 ()Tourner le disque D qui fixe la vanne à papillon selon les instructions suivantes.
- 10 Dévisser la vis VF.
- 11 tourner de 180° le disque D et fixer la vis VF .

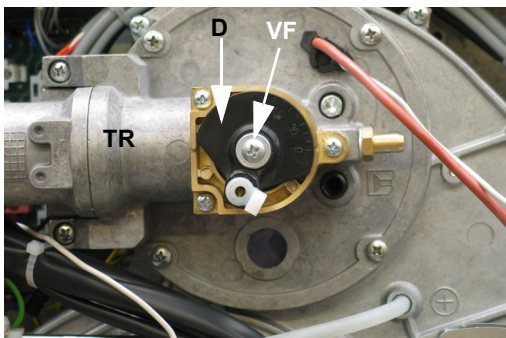

Fig. 10: Position standard

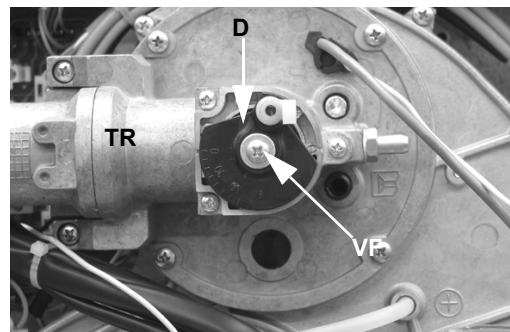

Fig. 11: Nouveau position

- 12 Reconnectez CR et AC.
- 13 Répéter les instructions des points 1-5 au contraire
- 14 Repositionnez le tirant T et accrochez-le avec le crochet en plastique G.

## RACCORDEMENTS DERAMPE GAZ

Les schémas suivants montrent les composants fournis avec le brûleur et ceux fournis par l'installateur. Les diagrammes sont conformes aux exigences légales.



**ATTENTION** : AVANT D'EFFECTUER LES RACCORDEMENTS AU RÉSEAU DE DISTRIBUTION DU GAZ, S'ASSURER QUE LES VANNES D'ARRÊT MANUELLES SONT FERMÉES. LIRE ATTENTIVEMENT LE CHAPITRE "AVERTIS AVERTIS AVERTIS AVERTIS AVERTIS DE CE MANUEL.

Rampe gaz avec groupe vannes MB-DLE (2 vannes + filtre gaz + stabilisateur de pression + pressostat) + contrôle d'étanchéité VPS504

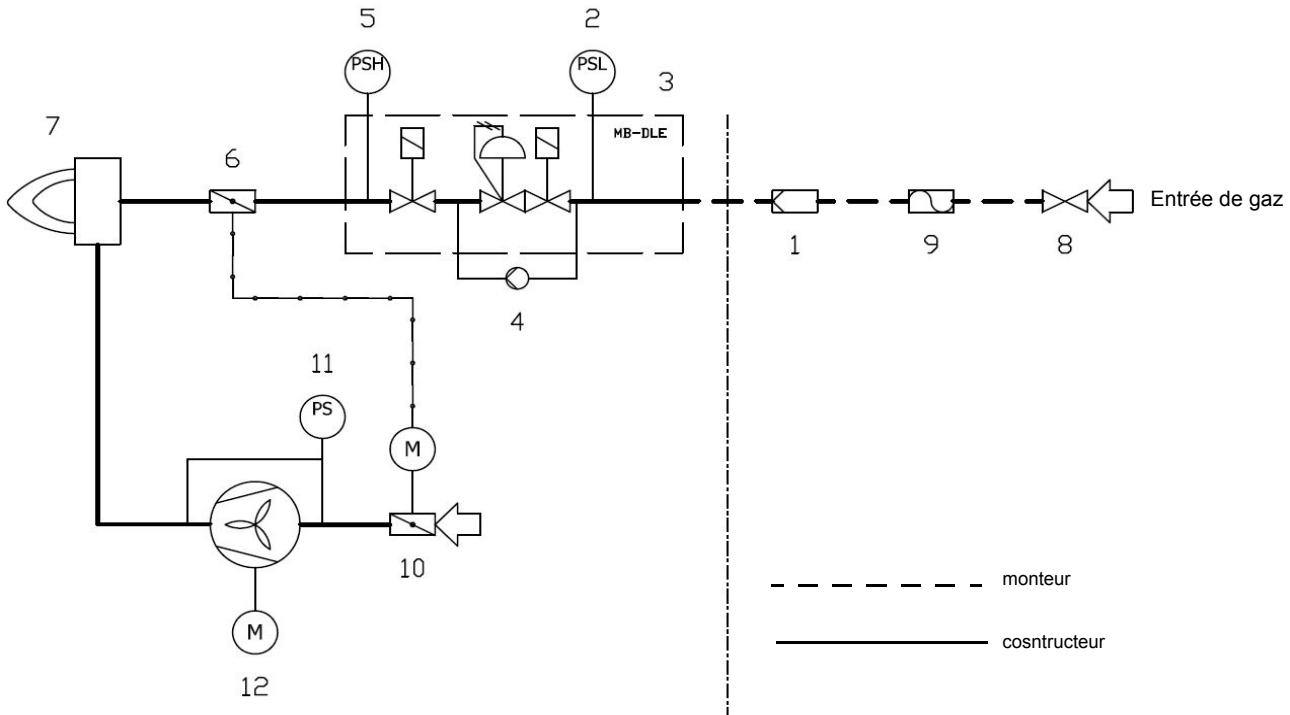

**\*Remarque** : Le pressostat peut être monté en amont ou en aval des vannes de gaz, mais en amont de la vanne papillon (voir schéma - élément 4).

- 1 Brûleur
- 2 Vanne papillon
- 3 Contrôle d'étanchéité (optional pour puissance < 1200 kW)
- 4 Pressostat gaz minimum (optional)
- 5 Pressostat gaz maximum
- 6 Filtre gaz
- 7 Joint antivibratoire
- 8 Robinet manuel d'interception
- 9 Vanne gaz avec stabilisateur de pression
- 10 Vanne gaz de sécurité

Pour installer la rampe à gaz, procédez comme suit :

- 1) en cas de raccords filetés : utiliser des raccords adaptés au gaz utilisé,
- 2) Fixer tous les composants avec des vis, selon les schémas indiqués, en respectant le sens de montage de chaque élément.

NOTE : Le joint anti-vibration, la vanne d'arrêt et les joints ne font pas partie de la fourniture standard.

**\*Remarque** : Le pressostat peut être monté en amont ou en aval des vannes de gaz, mais en amont de la vanne papillon (voir le tableau ci-dessous).

diagramme - élément 4).

La procédure d'installation de l'ensemble de la vanne de gaz est indiquée ci-dessous.



**ATTENTION** : nous conseillons de monter le filtre et les vannes de gaz de façon à qu'aucun corps étranger ne puisse tomber à l'intérieur des vannes lors des opérations d'entretien et de nettoyage des filtres (à l'extérieur et à l'intérieur du groupe des vannes) (cf. chapitre Entretien).



**ATTENTION** : une fois que la rampe a été installée selon le schéma indiqué, le circuit de gaz doit être soumis à un test d'étanchéité selon les méthodes prévues par la réglementation en vigueur.

## MultiBloc MB-DLE - Assemblage de la rampe gaz

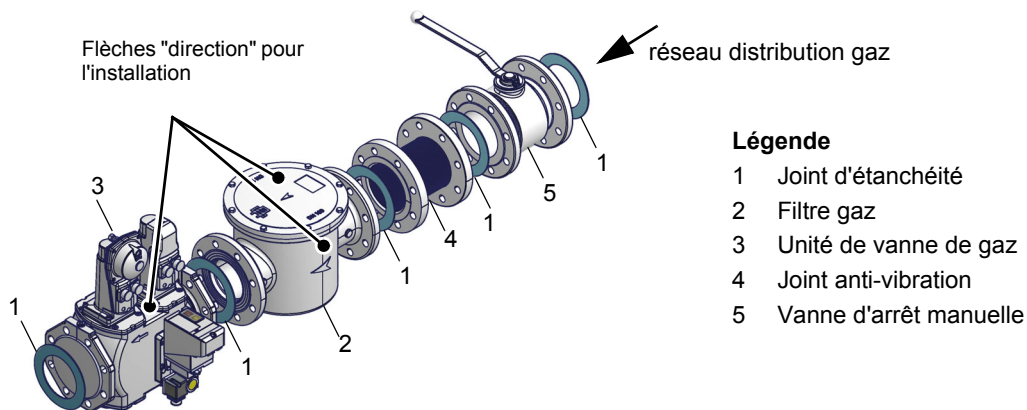

### Légende

- 1 Joint d'étanchéité
- 2 Filtre gaz
- 3 Unité de vanne de gaz
- 4 Joint anti-vibration
- 5 Vanne d'arrêt manuelle

### MULTIBLOC DUNGS Montage

**MB-DLE 405..412**  
**MB-DLE 415..420**

- 1 Monter la bride sur le tuyau: utiliser des raccords de gaz appropriés
- 2 Insérer l'unité **MB-DLE** et faire particulièrement attention aux joints toriques
- 3 Monter le MultiBloc entre les brides filetées
- 4 Après le montage, vérifier le serrage et le fonctionnement
- 5 Le démontage doit être effectué exactement dans l'ordre inverse

#### MB-DLE 405..412

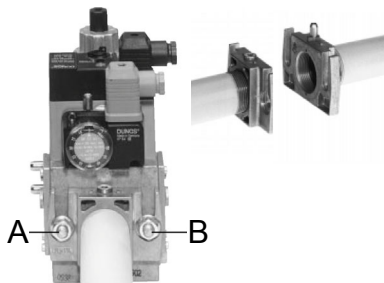

#### MB-DLE 415..420

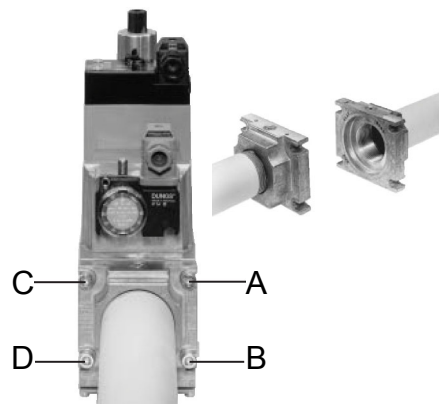

#### Position de montage

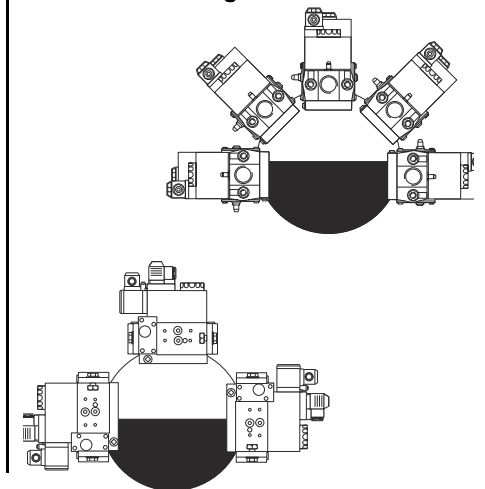

## SCHEMA POUR LES RACCORDEMENTS ELECTRIQUES

**ATTENTION:** le brûleur est fourni avec un pontet électrique entre les bornes T6 et T8 du connecteur CN2-TAB côté branchement externe (fiche mâle). En cas de branchement du thermostat flamme haute/basse, enlever ce pontet avant de brancher le thermostat.



**RESPECTER LES REGLES FONDAMENTALES DE SECURITE, CONTROLER LA MISE A LA TERRE, NE PAS INVERSER LES CONNEXIONS DE PHASE ET DE NEUTRE, PREVOIR UN INTERRUPTEUR DIFFERENTIEL MAGNETO THERMIQUE DE PUISSANCE ADAPTEE POUR LE RACCORDEMENT AU RESEAU ELECTRIQUE.**

**ATTENTION:** Le brûleur est livré avec un pont électrique entre les bornes 6 et 7. En cas de raccordement du thermostat 1ère/2ème allure enlever ce pont avant le raccordement du thermostat

Pour établir les connexions, procédez comme suit:

- 1 repérer le ou les connecteurs sortant du brûleur, selon le modèle:
  - Connecteur à 7 pôles pour l'alimentation électrique (pour tous les modèles) et la sonde MD;
  - Connecteur à 4 pôles (pour les brûleurs AB - à deux étages, PR - progressif, MD - modulant);
  - Connecteur à 3 broches ( NG/LG/NGX400);
- 2 effectuer les raccordements aux connecteurs, selon le modèle de brûleur (voir paragraphe suivant)
- 3 une fois les connexions vérifiées, vérifier le sens du moteur du ventilateur (voir paragraphe suivant)
- 4 le brûleur est prêt pour les prochains réglages.

Enlever le couvercle du tableau électrique sur le côté du brûleur. Exécuter les raccordements électriques sur le bornier d'alimentation selon les schémas; vérifier le sens de rotation du moteur du ventilateur (brûleurs en version triphase seulement) et remonter le couvercle du tableau électrique.



**IMPORTANT:** avant de faire fonctionner le brûleur, vérifier si tous les connecteurs sont branchés correctement, comme d'après les schémas joints.



**ATTENTION:** le brûleur est fourni avec un pont électrique entre les bornes T6 et T8 dans la prise 4-TAB du côté de la connexion externe (prise mâle). En cas de raccordement du thermostat TAB à flamme haute/basse, retirez ce pont avant de raccorder le thermostat.

Identification des connecteurs de branchement

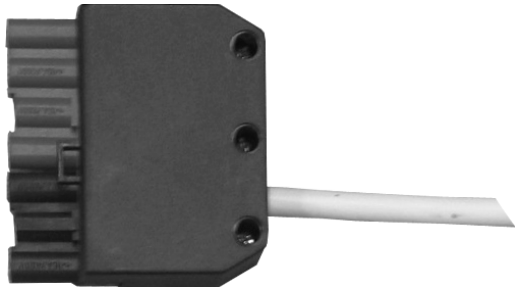
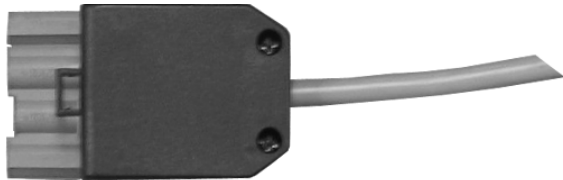
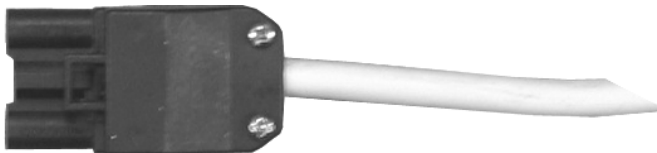
<p><b>Connecteur alimentation brûleur</b></p> <p><b>Connecteur branchement sondes(brûleurs modulant, )</b></p>	 <p>Fig. 12</p>
<p><b>Connecteur 1ère / 2ème allure(brûleurs progressives,</b></p>	 <p>Fig. 13</p>
<p><b>Connecteur moteur ventilateur (NG/NGX400)</b> (</p>	 <p>Fig. 14</p>



**IMPORTANT:** avant de faire fonctionner le brûleur, vérifier si tous les connecteurs sont branchés correctement, comme d'après les schémas joints.

Exécuter les raccordement électriques sur le bornier d'alimentation selon les schémas.

● : **Connecteurs pour brûleurs à un étage :**

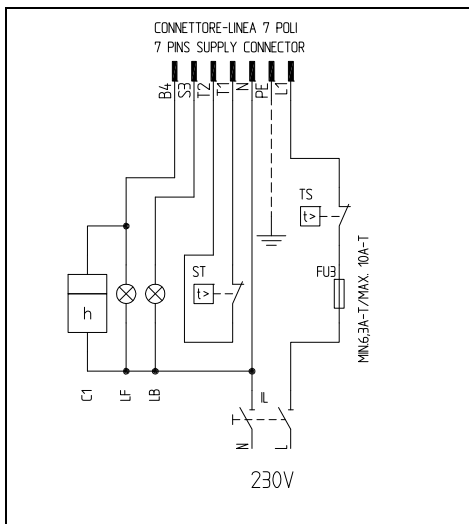

Fig. 15 - Brûleurs à 1 allure

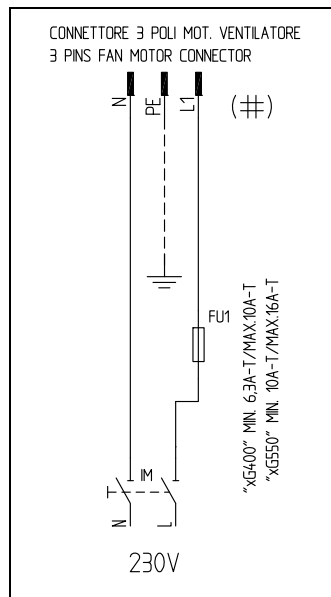

Fig. 16 Branchement moteur électrique NG/LG/NGX400

● : **Connecteurs pour brûleurs progressifs :**

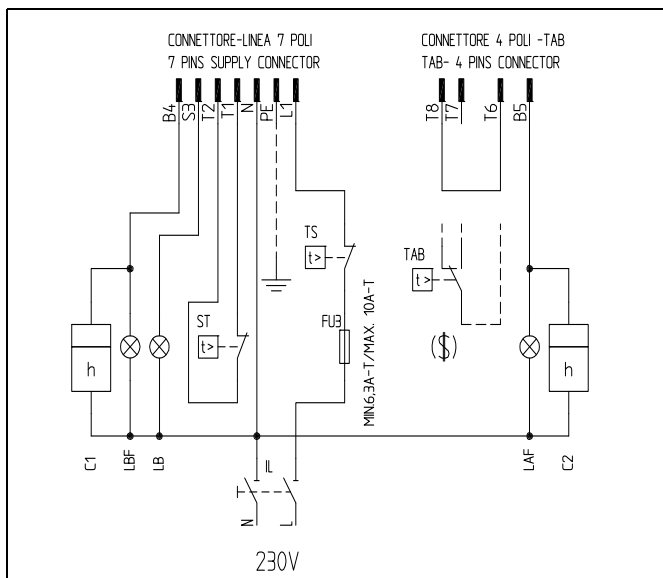

Fig. 17 - Brûleurs à deux allures

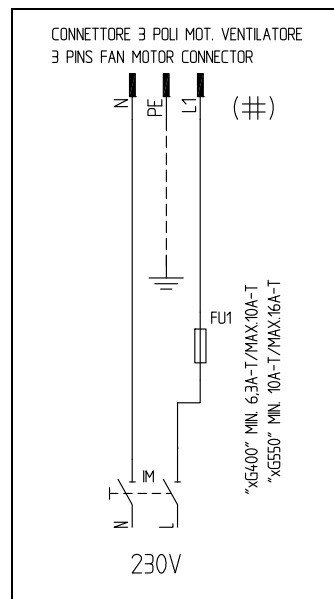

Fig. 18 Branchement moteur électrique NG/LG/NGX400

**Légende**

- C1 Compteur d'heures de fonctionnement 1ère allure
- C2 Compteur d'heures de fonctionnement 2ème allure
- FU1 Fusible de ligne moteur ventilateur
- FU3 Fusible de ligne
- IL Interrupteur de ligne brûleur
- IM Interrupteur de ligne moteur ventilateur
- KM1 Télérupteur moteur ventilateur
- LAF Voyant de signalisation brûleur
- LAF Voyant de signalisation brûleur en 2ème allure
- LB Voyant signalisation de mise en sécurité

- LBF Voyant de signalisation brûleur en 1ère allure
- MV Moteur ventilateur
- ST Série de thermostats ou de pressostats
- TAB Thermostat 1ère allure/2ème allure
- TS Thermostat/Pressostat de sécurité chaudière
- CONN-MOTORE Connecteur moteur ventilateur
- CONN-LINEA Connecteur alimentation brûleur
- CONN-TAB Connecteur 1ère/2ème allure
- (\$) Si prévu, "TAB", enlever le pont entre les bornes T6-T8

● : **Connecteurs pour brûleurs modulants :**

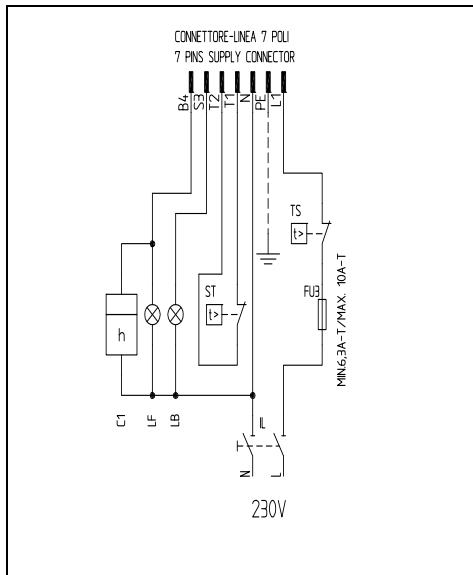

Fig. 19 - **Brûleurs modulants**

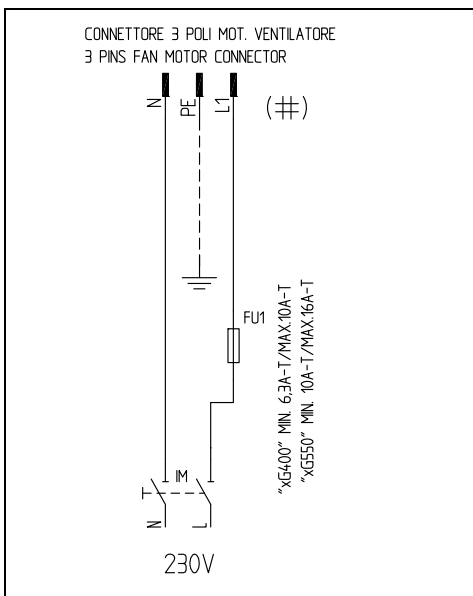

Fig. 20 - **Branchement moteur électrique NG/LG/NGXG400**

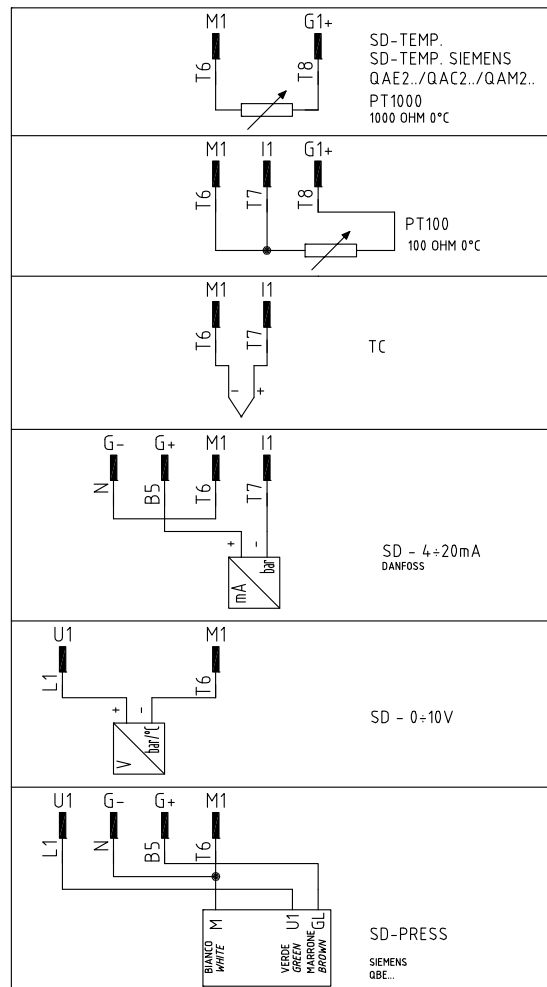

Fig. 21 - **Raccordement sondes**

**Légende**

- C1 Compteur d'heures de fonctionnement 1ère allure
- FU1 Fusible de ligne moteur ventilateur
- FU3 Fusible de ligne
- FU4 Fusible auxiliaire
- IL Interrupteur de ligne brûleur
- IM Interrupteur de ligne moteur ventilateur
- KM1 Télérupreur moteur ventilateur
- LANDIS RWF40Modulateur
- LB Voyant signalisation de mise en sécurité
- LBF Voyant de signalisation brûleur en 1ère allure

- MV Moteur ventilateur
- SD-0÷10VSignal en tension
- SD-0/4÷20mA Signal en courant
- SD-PRESSSonde de pression
- SMA Sélecteur de service: MAN - AUTO
- SMF Sélecteur manuel ou automatique; MIN - 0 - MAX
- ST Série de thermostats ou de pressostats
- TS Thermostat/Pressostat de sécurité chaudière



**RESPECTER LES REGLES FONDAMENTALES DE SECURITE, CONTROLER LA MISE A LA TERRE, NE PAS INVERSER LES CONNEXIONS DE PHASE ET DE NEUTRE, PREVOIR UN INTERRUPTEUR DIFFERENTIAL MAGNETO THERMIQUE DE PUISSANCE ADAPTEE POUR LE RACCORDEMENT AU RESEAU ELECTRIQUE.**

## Alimentation du brûleur sans neutre

Si l'alimentation électrique du brûleur est de 230 V phase à phase (sans conducteur neutre), le Siemens LME2... (pour plus d'informations sur le dispositif LME..., voir l'annexe), il faut ajouter le circuit RC Siemens, RC466890660, comme indiqué sur la figure.

### Légende

C - Condensateur (22nF/250V)

R - Résistance (1Mohm)

(\*\*\*) RC466890660 - Circuit RC Siemens (Code : 2531003)

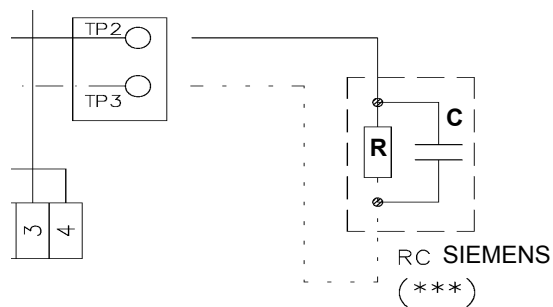

## Montage du support de commande

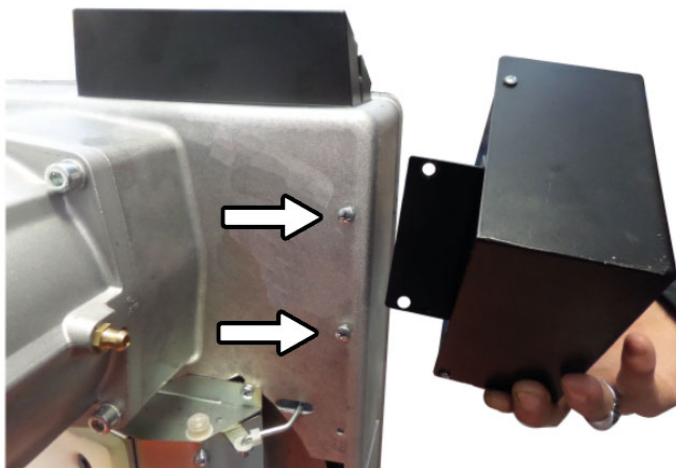
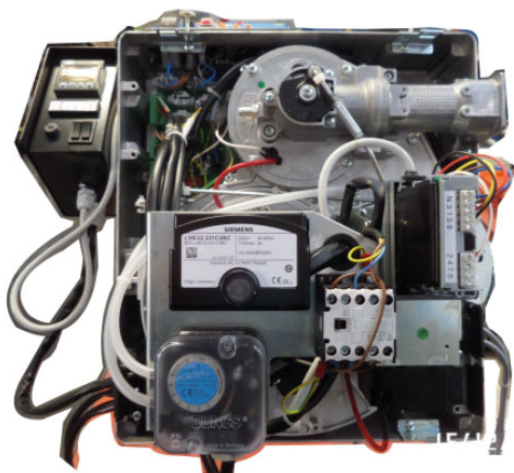

Effectuez le montage comme indiqué sur la figure.

**PARTIE III: MANUEL D'UTILISATION****LIMITES D'UTILISATION**

**LE BRULEUR EST UN APPAREIL CONÇU ET CONSTRUIT POUR NE FONCTIONNER QU'APRES AVOIR ETE CORRECTEMENT ACCOUPLE A UN GENERATEUR DE CHALEUR (EX. CHAUDIERE, GENERATEUR D'AIR CHAUD, FOUR, ETC.). TOUTE AUTRE UTILISATION DOIT ETRE CONSIDEREE COMME IMPROPRE ET PAR CONSEQUENT DANGEREUSE.**

**L'UTILISATEUR DOIT GARANTIR LE MONTAGE CORRECT DE L'APPAREIL EN S'ADRESSANT AU PERSONNEL QUALIFIE POUR LA REALISATION DE L'INSTALLATION. LE PREMIER ALLUMAGE DEVRA ETRE EFFECTUE PAR UN TECHNICIEN D'UN SERVICE APRES-VENTE AGREE PAR LE CONSTRUCTEUR.**

**A CE PROPOS, LA CONNEXION ELECTRIQUE AUX ORGANES DE REGLAGE ET DE SECURITE DU GENERATEUR (THERMOSTATS DE TRAVAIL, SECURITE, ETC.) ASSUME UNE IMPORTANCE FONDAMENTALE ET GARANTIT UN FONCTIONNEMENT CORRECT ET SANS DANGER DU BRULEUR.**

**LA MISE EN SERVICE DE L'APPAREIL EST ASSUJETTIE AU RESPECT DES MODALITES D'INSTALLATION PRESCRITES PAR LE CONSTRUCTEUR. TOUTE MANIPULATION (EX. DECONNEXION TOTALE OU PARTIELLE DE CONDUCTEURS ELECTRIQUES, OUVERTURE DE LA PORTE DU GENERATEUR, DEMONTAGE DE PARTIES DU BRULEUR) VISANT A APPORTER, TOTALEMENT OU EN PARTIE, CERTAINES MODIFICATIONS EST FORMELLEMENT INTERDITE.**

**NE JAMAIS OUVRIR OU DEMONTER AUCUN COMPOSANT DE L'APPAREIL.**

**AGIR EXCLUSIVEMENT SUR L'INTERRUPTEUR GENERAL («ON-OFF») QUI SERT EGALEMENT POUR L'ARRET D'URGENCE ETANT DONNE SON ACCES FACILE GRÂCE À LA RAPIDITE DE LA MANOEUVRE; EVENTUELLEMENT AGIR SUR LE BOUTON DE DEVERROUILLAGE.**

**EN CAS D'ARRÊT DE BLOCAGE, DÉBLOQUER L'APPAREIL EN APPUYANT SUR LE BOUTON RESET PRÉVU À CET EFFET. EN CAS D'UN NOUVEL ARRÊT DE BLOCAGE, CONTACTER LE SERVICE APRÈS-VENTE SANS FAIRE AUCUNE AUTRE TENTATIVE.**

**ATTENTION: DURANT LE FONCTIONNEMENT DE L'APPAREIL, LES PARTIES DU BRULEUR PROCHES DU GENERATEUR (BRIDE D'ACCOUPLMENT) CHAUFFENT. NE PAS LES TOUCHER AFIN D'EVITER TOUT RISQUE DE BRULURE.**

## FONCTIONNEMENT

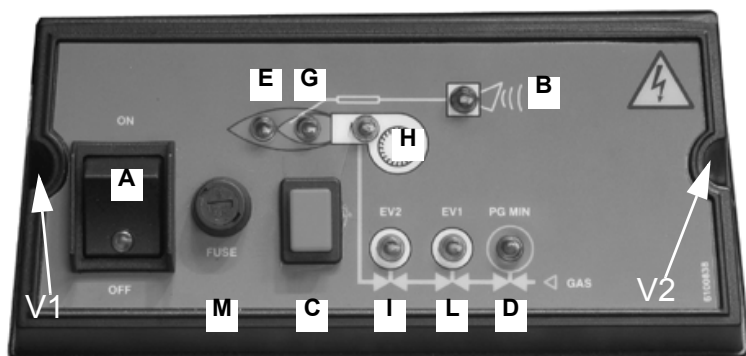

Fig. 22 -

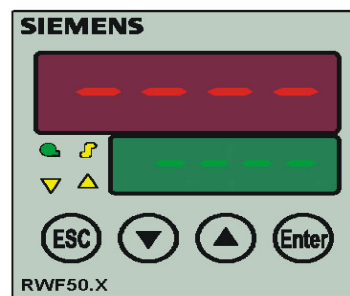

Fig. 23 - RWF50

### Légende

- A - Interrupteur principal marche - arrêt
- B - Témoin de verrouillage
- C - Bouton de libération de l'unité de contrôle du brûleur (option)
- D - Témoin de consentement du pressostat de pression minimale de gaz
- E - Témoin lumineux de flamme vive (ou registre d'air ouvert, si le budget le permet)
- G - Témoin lumineux de fonctionnement à faible flamme
- H - Témoin de fonctionnement du transformateur d'allumage
- I - Lampe d'ouverture de la valve EV2
- L - Lampe d'ouverture de la valve EV1
- M - Fusible

- Placez l'interrupteur A du panneau de commande du brûleur sur la position ON. Vérifier que le dispositif de contrôle de la flamme (voir annexe) n'est pas en position de verrouillage (voyant B allumé) : si nécessaire, le déverrouiller en appuyant sur le bouton C (reset) pendant plus de 0,5 secondes mais moins de 3 secondes ;
- Vérifiez que l'ensemble des thermostats (ou pressostats) donne l'accord de fonctionnement du brûleur.
- Vérifiez que la pression d'alimentation en gaz est suffisante (indiquée par l'allumage du voyant D).

**Uniquement pour les brûleurs équipés d'un contrôle d'étanchéité** : le cycle de contrôle du dispositif de contrôle d'étanchéité de la vanne gaz commence, la fin du contrôle est indiquée par le voyant du dispositif de contrôle d'étanchéité.

- En cas de fuite d'une vanne gaz, le dispositif de contrôle de l'étanchéité de la vanne gaz se verrouille et le voyant rouge du contrôle de l'étanchéité s'allume (voir page 105). Pour déverrouiller le dispositif, appuyez sur le bouton de déverrouillage du dispositif de contrôle d'étanchéité (voir page 105). Une fois le contrôle de la vanne de gaz terminé, le cycle de démarrage du brûleur commence. **Pour tous les brûleurs** : Au début du cycle de démarrage, le servocontrôle amène le registre d'air en position d'ouverture maximale, puis le moteur du ventilateur démarre et la phase de préamorçage commence.
- Pendant la phase préventive, l'ouverture complète du volet d'air est signalée par le voyant E sur le panneau frontal.
- A la fin de la prépure, le registre d'air se déplace en position de flamme basse (environ 30°), le transformateur d'allumage est inséré (indiqué par le voyant de contrôle H sur le panneau) et, après 3 secondes, les deux vannes de gaz EV1 et EV2 sont alimentées (voyants de contrôle L et I sur le panneau).
- La flamme doit se former dans le délai de sécurité (3 secondes après l'ouverture des vannes de gaz), sinon le contrôleur de flamme se verrouille. Quelques secondes après l'ouverture des vannes de gaz, le transformateur d'allumage et la lampe témoin H s'éteignent. Le brûleur est allumé comme suit
- Quelques secondes après l'ouverture des vannes de gaz, le brûleur entre dans la phase de fonctionnement automatique.

**Pour les brûleurs à un étage** : le brûleur est maintenant allumé à pleine puissance, les indicateurs E et G sont allumés ;

**Pour les brûleurs à deux allures** : le brûleur est allumé, en flamme basse (voyant G allumé) ; après 8 secondes, le fonctionnement à deux allures commence et le brûleur passe automatiquement en flamme haute (voyant E allumé), ou reste en flamme basse selon les exigences du système.

**Pour les brûleurs modulants** : les brûleurs modulants sont équipés d'un régulateur modulant Siemens RWF40 installé sur un côté du brûleur. Pour le fonctionnement du régulateur, veuillez vous reporter au manuel correspondant.

## RÉGLAGES DU DÉBIT D'AIR ET DE GAZ



**ATTENTION:** avant de démarrer le brûleur, assurez-vous que les vannes d'arrêt manuelles sont ouvertes et vérifiez que la valeur de la pression en amont de la rampe est conforme aux valeurs indiquées dans la section "Données techniques". Assurez-vous également que l'interrupteur principal est fermé.



**AVERTISSEMENT:** Lors des opérations de calibrage, veillez à ne pas faire fonctionner le brûleur avec un débit d'air insuffisant (risque de formation de monoxyde de carbone) ; si cela se produit, réduisez lentement le combustible à des valeurs de combustion normales.



**ATTENTION:** LES VIS SCELLÉES NE PEUVENT POUR AUCUNE RAISON ÊTRE DESSERRÉES. SI C'ÉTAIT LE CAS LA GARANTIE SUR LES COMPOSANTS SERA IMMÉDIATEMENT NON VALABLE!

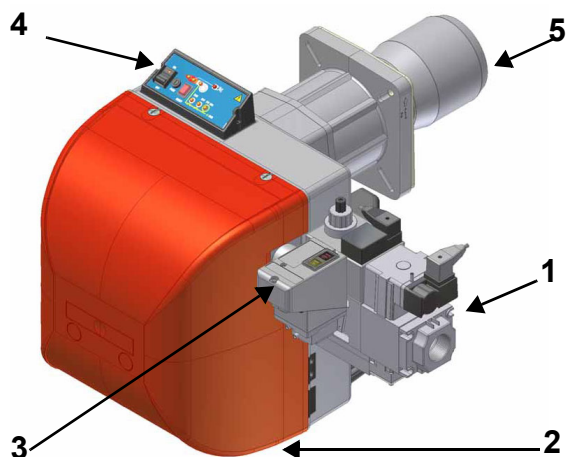

Fig. 24

### Légende

- 1 Groupe de vannes
- 2 Capot
- 3 Test de fuite
- 4 Panneau de contrôle
- 5 Bouche

Pour effectuer les réglages, dévisser les vis de fixation et retirer le chapeau du brûleur (voir Fig. 82-2).

### Puissance d'allumage

La puissance d'allumage ne doit pas dépasser 120 kW (sur les brûleurs à un étage) ou 1/3 de la puissance maximale de fonctionnement (sur les brûleurs à deux étages, progressifs ou modulant). Pour répondre à ces exigences, les brûleurs sont équipés de vannes papillon et/ou de soupapes de sécurité à ouverture lente. Sur les brûleurs à deux allures, progressifs ou modulant, la flamme basse doit être supérieure à la puissance minimale de la plage de fonctionnement.

**IMPORTANT!** l'excès d'air de combustion doit être réglé selon les paramètres recommandés indiqués dans le tableau suivant :

Paramètres de combustion recommandés		
Combustible	CO <sub>2</sub> Recommandé (%)	O <sub>2</sub> Recommandé (%)
Gaz naturel	9 ÷ 10	4,8 ÷ 3
	11 ÷ 12	4,3 ÷ 2,8

### Cames

Reportez-vous au tableau suivant pour l'étalonnage :

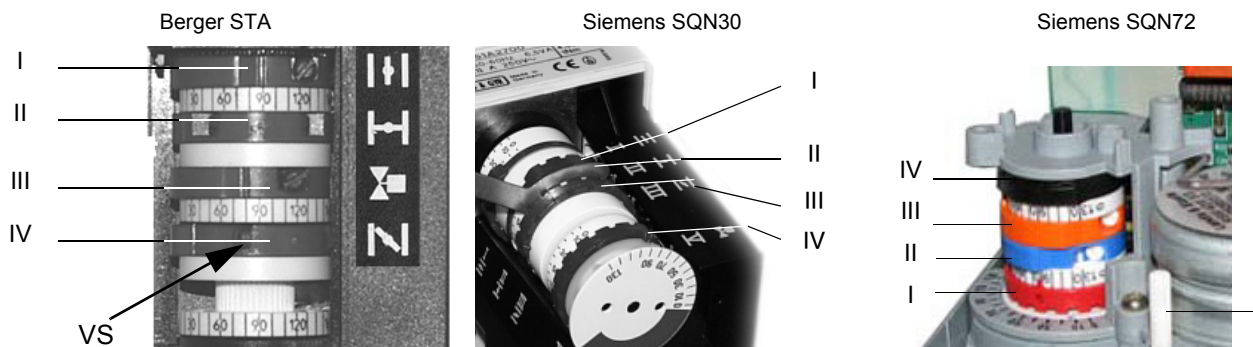

	BERGER STA	Siemens SQN30	Siemens SQN72
Position haute de la flamme (à positionner à 90°)	I	I	I (rouge)
Position basse de la flamme et allumage	IV	III	III (orange)
Position d'arrêt (à positionner à 0°)	II	II	II (bleu)
Non utilisé	III	V	IV (noir)

- Remarque : Pour déplacer les cames du servo, utilisez :
- Berger STA : clé fournie pour déplacer les cames
- Siemens SQN72 : clé fournie pour les cames I et IV, vis de réglage sur les autres cames. Les servocommandes
- BERGER STA6B3.41 e STA12B3.41, ne sont pas prévus avec la servo commande manuelle du clapet air.

## Réglage de groupe des vannes

### Multibloc MB-DLE

Le multibloc est un groupe compact composé de deux vannes, du pressostat gaz, du régulateur de pression et du filtre gaz.

Il est normalement combiné aux dispositifs de contrôle d'étanchéité Dungs VPS504.

Le réglage de la vanne gaz s'effectue au moyen du régulateur RP, après avoir desserré de quelques tours la vis de blocage VB.

Dévisser la vis RP pour augmenter la pression, visser pour la diminuer. Une fois cette opération terminée, bloquer la vis VB.

Pour le réglage du déclencheur rapide, enlever la calotte T, la retourner et l'introduire sur le pivot VR avec la rainure prévue à cet effet positionnée sur la partie supérieure. En visant, le débit d'allumage diminue. En dévissant, le débit d'allumage augmente.

### Ne pas régler la vis VR avec un tournevis!

Pour régler le régulateur de pression, agir sur la vis VS située sous le couvercle C; visser pour augmenter la pression, dévisser pour la diminuer.

**N.B.:** La vis VSB ne doit être enlevée que pour remplacer la bobine.

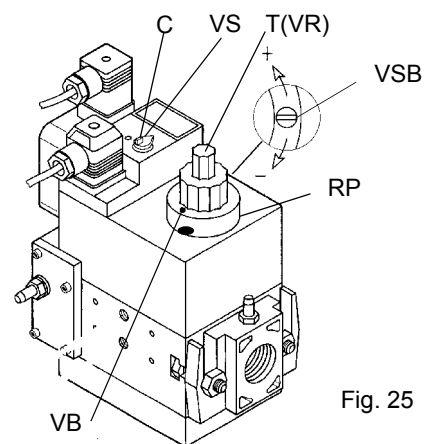

Fig. 25

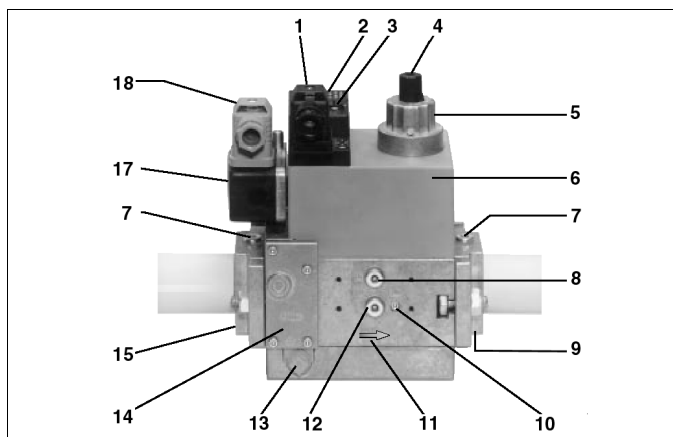

Fig. 26

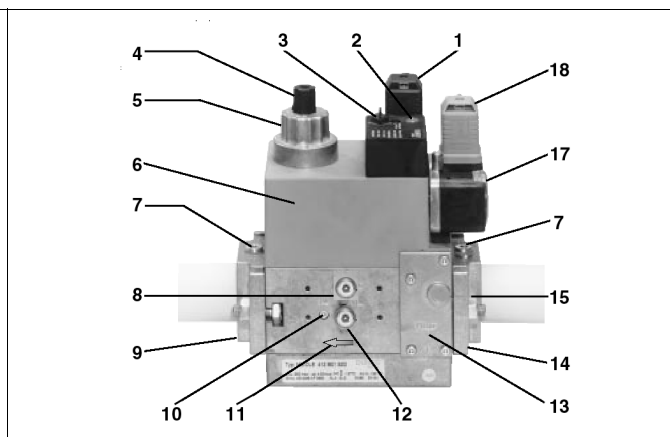

Fig. 27

### Légende

- |  |   |
|--|---|
| 1 Raccordement électrique de l'électrovanne                | 9 Bride de sortie   |
| 2 Indicateur de marche (option)                            | 10 Prise de pression M4 après V2                            |
| 3 Bouchon de fermeture stabilisateur de pression           | 11 Direction du flux de gaz                                 |
| 4 Coperchietto di regolazione start                        | 12 Prise de pression G 1/8 avant V1 possible des deux côtés |
| 5 Frein hydraulique et réglage débit                       | 13 Regolatore di pressione ugello di sfiato                 |
| 6 Bobine   | 14 Filtre (sous le couvercle)                               |
| 7 Prise de pression G 1/8 possible                         | 15 Bride d'entrée   |
| 8 Prise de pression G 1/8 après V1 possible des deux côtés | 16 Pressostat   |
|  | 17 Raccordement électrique du pressostat                    |

### Tête de combustion

Le brûleur est réglé en usine avec la tête de combustion en position de puissance maximale "MAX". Le réglage de la puissance maximale correspond à la position "tout en avant" de la tête de combustion, pour les brûleurs de type standard et à la position "tout en arrière" pour les brûleurs à faible émission de NOx. Pour le fonctionnement à puissance réduite, déplacez progressivement la tête de combustion vers la position "MIN" en tournant la vis VRT dans le sens horaire. L'indice ID indique le déplacement de la tête de combustion.

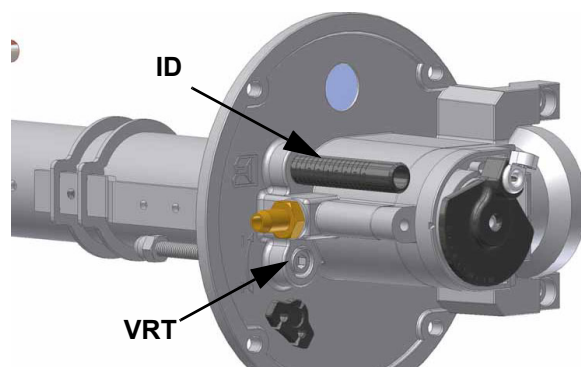

Fig. 28

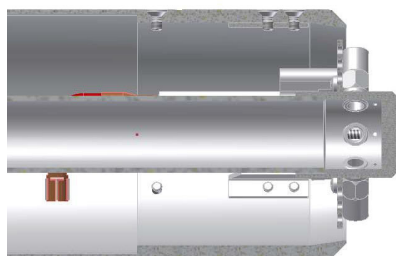

Fig. 29 La tête en avant

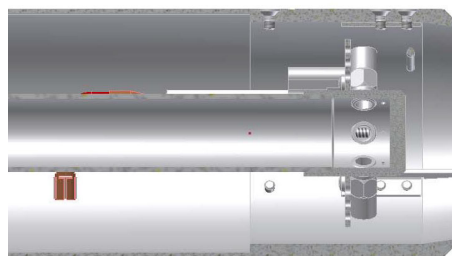

Fig. 30 Revenir sur ses pas

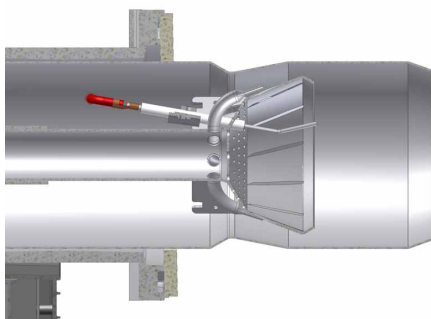

Fig. 31 La tête en avant

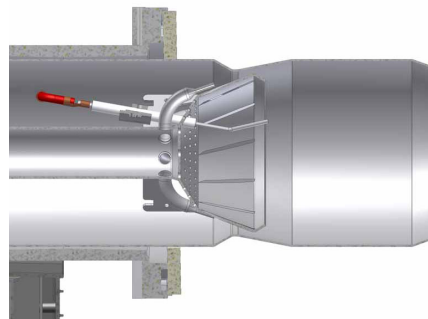

Fig. 32 Revenir sur ses pas

## Procédure de réglage

Pour modifier le réglage du brûleur pendant la réception à l'installation, suivre les procédures ci-dessous.

**⚠** Procéder aux réglages de l'air et du gaz : tout en surveillant constamment l'analyse des fumées, afin d'éviter une combustion par manque d'air, doser l'air en fonction de la variation du débit de gaz effectuée selon la procédure ci-dessous.

**⚠** Le groupe de réglage de la pression est préréglé en usine. Ces réglages doivent être ajustés lors de la mise en route de l'installation suivant les indications et recommandations du constructeur des brûleurs!

### ● Régulation pour les brûleurs à un étage

- 1 retirez le capot du brûleur,
- 2 démarrer le brûleur en mettant l'interrupteur principal A du brûleur sur ON: en cas de blocage (indiqué par la LED B du panneau de commande) appuyer sur le bouton RESET (C) du panneau du brûleur.
- 3 Procéder au réglage du débit d'air : desserrer la vis VR (voir figure). Déplacez l'index ID vers + ou - pour augmenter ou diminuer le débit d'air, en fonction des valeurs de combustion requises ;Resserrer la vis VR
- 4 Pour régler le débit de gaz, agir directement sur le stabilisateur de l'unité de vanne (voir paragraphe

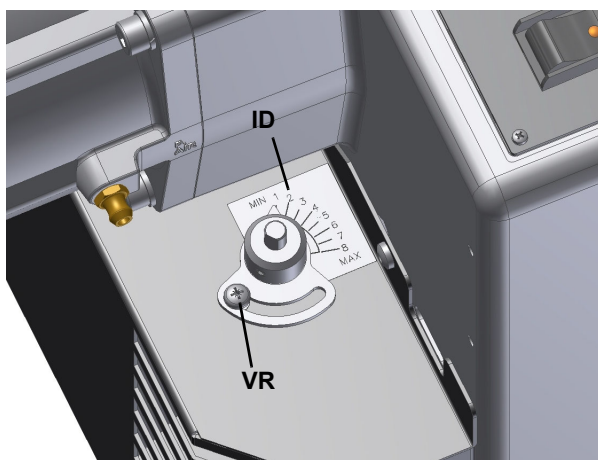

LG/NG/NGX280 - TN

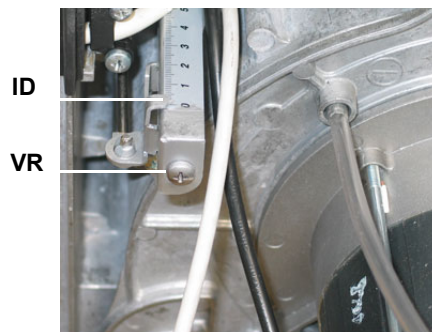

LG/NG/NGX350-400 TN

### ● Régulation pour les brûleurs à deux allures - mod. LG/NG/NGX280

- 1 retirez le capot du brûleur,
- 2 Avant d'allumer le brûleur, afin d'atteindre en toute sécurité la position de flamme haute, mettez le micro-interrupteur de flamme haute de la servocommande sur la position de flamme basse (de manière à faire fonctionner le brûleur à la puissance minimale).
- 3 démarrer le brûleur en mettant l'interrupteur principal A du brûleur sur ON (Fig. 78) : en cas de blocage (indiqué par la LED B du panneau de commande) appuyer sur le bouton RESET (C) du panneau du brûleur.
- 4 Déplacez la came de flamme haute du servocontrôle pour ouvrir le servocontrôle de quelques degrés. La servocommande ouvre la vanne papillon de gaz au moyen du levier L et ouvre en même temps le clapet d'air au moyen de la came fendue de l'unité de commande.
- 5 Si nécessaire, après avoir vérifié que la combustion est conforme aux paramètres recommandés dans le tableau du paragraphe "Puissance d'allumage". " ". Réglez la position du volet d'air en agissant sur la came fendue.
- 6 Procédez de cette manière jusqu'à ce que l'ouverture maximale de la servocommande soit atteinte..
- 7 Pour régler le débit de gaz, agir directement sur le stabilisateur de l'unité de vanne.
- 8 Ajustez la position de la tête de combustion si nécessaire.
- 9 Une fois le point de combustion réglé sur flamme haute, régler le brûleur sur flamme basse en agissant sur le thermostat TAB haute/basse de la chaudière, en vérifiant la combustion point par point.
- 10 Pour corriger le débit de gaz en cas de flamme basse, si nécessaire, desserrer la vis V1 et régler l'angle d'ouverture de la vanne papillon en faisant tourner la plaque C à l'aide de la vis V3 (la rotation dans le sens des aiguilles d'une montre diminue le débit de gaz, la rotation dans le sens inverse l'augmente). L'indice S indique l'angle d'ouverture. Note : S'il est nécessaire de modifier la puissance du brûleur en feu doux, après avoir effectué tous les réglages, agir sur la came correspondante de la servocommande (voir paragraphe suivant). Après cette opération, contrôler le débit de gaz et, si nécessaire, reprendre à partir du point 1. Vérifiez à nouveau la combustion et le débit de gaz du brûleur à flamme haute.

11 Vérifiez à nouveau la combustion et le débit de gaz du brûleur à flamme haute..

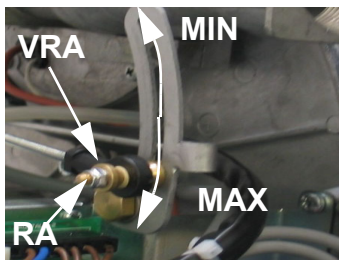

Fig. 33

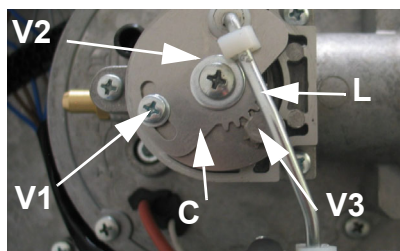
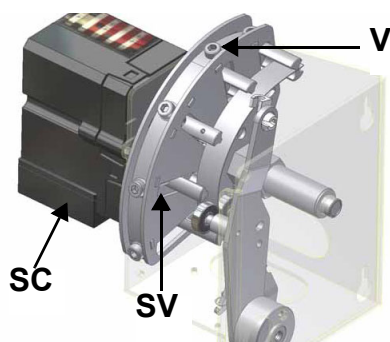

Fig. 34

● **Contrôle progressif ou modulant**

- 1 Avant de mettre en marche le brûleur, afin d'atteindre en toute sécurité la position de flamme haute, amener le micro-interrupteur de flamme haute du servocontrôle sur la position de flamme basse (de sorte que le brûleur fonctionne à la puissance minimale).
- 2 démarrer le brûleur en mettant l'interrupteur principal A du brûleur sur ON : en cas de blocage (indiqué par la LED B du panneau de commande) appuyer sur le bouton RESET (C) du panneau du brûleur.
- 3 régler le brûleur sur la flamme haute à l'aide du thermostat TAB (thermostat flamme haute-basse - voir les schémas électriques) ; pour les brûleurs modulants, voir le paragraphe correspondant.
- 4 Déplacez ensuite le micro-interrupteur de flamme haute du servocontrôle vers des valeurs progressivement plus élevées jusqu'à atteindre la position de flamme haute, en contrôlant toujours les valeurs de combustion et en réglant le débit d'air et de gaz si nécessaire.
  - Pour régler le débit d'air, procéder comme suit : situer la vis V du secteur variable SV, correspondant aux paliers qui glissent sur la lame, par rapport à la position de la servocommande ; Dévissez la vis V pour augmenter le débit d'air ou vissez-la pour le diminuer ;
  - Pour régler la pression de gaz, agir sur le stabilisateur de l'unité de vanne
- 5 Une fois que la position haute de la flamme a été atteinte, ouvrez complètement la vanne de gaz. Pour atteindre le débit requis, régler le stabilisateur
- 6 Ajustez la position de la tête de combustion si nécessaire
- 7 une fois la capacité maximale établie, court-circuiter avec un pont pendant un moment les bornes T6 et T7 relatives au thermostat TAB ; pour les brûleurs modulants voir le paragraphe suivant. Le servocontrôle se déplace vers la position flamme basse, jusqu'à la vis V suivante ; puis retirez le pont ;
- 8 puis réglez la vis V pour cette position ;
- 9 répéter les opérations pour toute la course de la servocommande afin d'établir le profil complet de la feuille.

Note : S'il est nécessaire de modifier la puissance du brûleur en feu doux, agir directement sur la came correspondante de la servocommande. Après cette opération, contrôler le débit de gaz et vérifier les valeurs de combustion. En cas de manque ou d'excès d'air, agir sur les vis V du secteur variable (voir figure) en correspondance avec le point de réglage de l'air de la flamme basse (dévisser augmente le débit, visser le diminue).



**Brûleurs modulants**

Per regolare i bruciatori modulanti, servirsi del selettore **CMF** presente sul pannello di controllo del bruciatore (vedi figura), invece di utilizzare il termostato **TAB** come descritto nella regolazione dei bruciatori progressivi. Procedere alla regolazione come descritto nei paragrafi precedenti, facendo attenzione all'impiego del selettore **CMF**.

La posizione del selettore determina gli stadi di funzionamento: per portare il bruciatore in alta fiamma, porre il selettore CMF a 1, per portarlo in bassa fiamma porre **CMF** a 2.

Per fare ruotare il settore variabile si deve porre il selettore CMF a 1 oppure 2 e poi portarlo a 0.

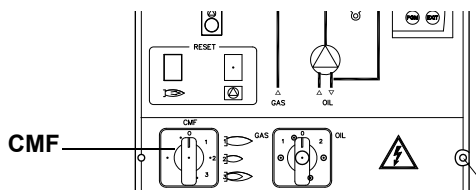

- CMF = 0 Servocontrol stationnaire dans sa position actuelle
- CMF = 1 fonctionnement à flamme élevée
- CMF = 2 fonctionnement à flamme basse
- CMF = 3 opération automatique

### Contrôle d'étanchéité VPS504 (OPTION)

Leur fonction est de contrôler l'étanchéité des vannes de fermeture du gaz constituant le Multibloc. Ce contrôle est effectué dès que le thermostat de chaudière donne l'ordre de mise en service du brûleur en créant, à travers la pompe à membrane située à l'intérieur, une pression dans le circuit d'essai de 20 mbars supérieure à la pression d'alimentation). Si l'on désire procéder à une vérification, introduire un manomètre en correspondance de la prise de pression PA (). Si le cycle d'essai résulte positif, le voyant d'autorisation LC (jaune) s'allume après quelques secondes. En cas contraire, c'est le voyant LB de mise en sécurité (rouge) qui s'allume. Pour repartir, il est nécessaire de réarmer le coffret en pressant la voyant/bouton LB.

Pour installer le contrôle d'étanchéité DUNGS VPS504 sur les vannes MD-DLE, procédez comme suit :

interrompre l'alimentation en gaz ;

- 1 interrompre l'alimentation électrique ;
- 2 retirer les vis de blocage de l'ensemble Multibloc ;
- 3 Insérez les bagues d'étanchéité (10,5 x 2,25) dans le VPS 504 ;
- 4 Serrez les 4 vis du test d'étanchéité (M4 x 16) Fig. 105-C.
- 5 Après avoir terminé, effectuez un contrôle d'étanchéité et de fonctionnement.

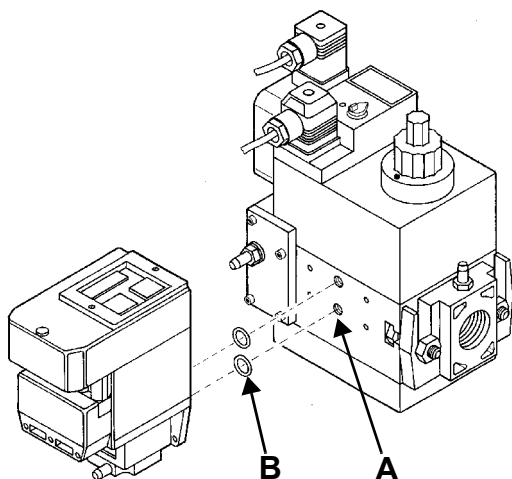

Fig. 35

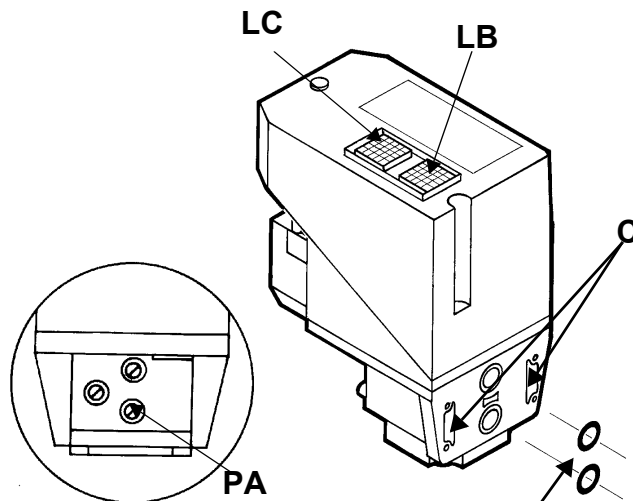

Fig. 36

Pour effectuer le test de fonctionnement, insérez un manomètre sur la prise de pression PA . Si le cycle de test est réussi, le voyant de consentement LC (jaune) s'allume après quelques secondes. Sinon, le voyant de blocage LB (rouge) s'allume. Pour redémarrer, l'équipement doit être déverrouillé en appuyant sur le bouton LB.

## Réglage des pressostats d'air et de gaz

Le pressostat air sert à mettre en sécurité (bloquer) l'appareil de contrôle de la flamme si la pression de l'air n'est pas celle prévue. En cas de blocage, débloquent le brûleur à l'aide de la touche de déblocage de l'appareil, placé sur le tableau de contrôle du brûleur. Les pressostats gaz contrôlent la pression pour empêcher le fonctionnement du brûleur si la valeur de la pression n'est pas comprise dans la plage de pression admise.



### Réglage pressostat gaz maximum (en option)

- Le pressostat gaz maximum est monté sur le brûleur à proximité de la vanne-papillon et il est raccordé à cette dernière par un petit tuyau en cuivre. Pour le réglage, procéder de la manière suivante:
- Retirer le couvercle en plastique transparent.
- Amener le brûleur à la puissance maximum.
- Tourner lentement la bague de réglage **VR** en sens horaire, jusqu'à l'arrêt du brûleur.
- Tourner légèrement la bague de réglage en arrière (augmenter la valeur indiquée sur la bague après la rotation de 20% environ).
- Répéter le cycle d'allumage du brûleur et contrôler que le brûleur démarre correctement. En cas d'arrêt, tourner encore légèrement la bague de réglage en arrière.
- Remonter le couvercle en plastique transparent.

### Réglage pressostat air

Procéder au réglage du pressostat air de la façon suivante:

- Enlever le couvercle en plastique transparent.
- Après avoir effectué les réglages de l'air et du gaz, allumer le brûleur.
- Commence le cycle de pré ventilation. Attendre 10 s et tourner dans le sens des aiguilles d'une montre la bague de régulation VR en amenant le brûleur en blocage, lire la valeur de la pression sur l'échelle du pressostat et réduire cette valeur de 15%.
- Répéter le cycle d'allumage du brûleur et contrôler que celui-ci fonctionne correctement.
- Remonter le couvercle en plastique transparent sur le pressostat.

### Calibrage du pressostat gaz minimum

Pour le calibrage du pressostat suivre le procédé suivant.

- Enlever le couvercle en plastique transparent
- Mesurer la pression à la prise de pression sur le pressostat de pression minimum pendant le service du brûleur; fermer lentement le robinet manuel d'alimentation (voir "SCHEMA D'INSTALLATION DE LA RAMPE GAZ") jusqu'à obtention d'une réduction de 50% de la pression. Vérifier les émissions CO du brûleur: si les valeurs sont inférieures aux 80 ppm tourner l'embout de réglage jusqu'à l'arrêt du brûleur. Si les valeurs de CO sont supérieures aux 80 ppm, ouvrir le robinet d'alimentation jusqu'à réduction de la valeur de CO à 80 ppm, ensuite tourner l'embout de réglage jusqu'à l'arrêt du brûleur.
- Ouvrir complètement le robinet manuel d'interception gaz.

Remonter le couvercle en plastique transparent sur le pressostat.

### Réglage pressostat gaz maximum (en option)

- Le pressostat gaz maximum est monté sur le brûleur à proximité de la vanne-papillon et il est raccordé à cette dernière par un petit tuyau en cuivre. Pour le réglage, procéder de la manière suivante:
- Retirer le couvercle en plastique transparent.
- Amener le brûleur à la puissance maximum.
- Tourner lentement la bague de réglage **VR** en sens horaire, jusqu'à l'arrêt du brûleur.
- Tourner légèrement la bague de réglage en arrière (augmenter la valeur indiquée sur la bague après la rotation de 20% environ).
- Répéter le cycle d'allumage du brûleur et contrôler que le brûleur démarre correctement. En cas d'arrêt, tourner encore légèrement la bague de réglage en arrière.
- Remonter le couvercle en plastique transparent.

## PARTIE IV: ENTRETIEN

Au moins une fois par an effectuer les opérations d'entretien illustrées ci-après. En cas de fonctionnement saisonnier, il est recommandé de procéder à l'entretien à la fin de chaque période de chauffage. En cas de fonctionnement continu l'entretien doit être effectué tous les six mois.



**ATTENTION: TOUTES LES INTERVENTIONS SUR LE BRÛLEUR DOIVENT ÊTRE EXÉCUTÉES AVEC L'INTERRUPTEUR ÉLECTRIQUE GÉNÉRAL OUVERT ET SOUPAPES MANUELLES D'INTERCEPTION DES COMBUSTIBLES ÉCLUSES.**

**ATTENTION: LIRE SCRUPULEUSEMENT LES INSTRUCTIONS INDIQUÉES AU DÉBUT DU MANUEL**

## OPÉRATIONS PÉRIODIQUES

- Nettoyage des filtres des vannes de gaz
- Démontage de l'examen et nettoyage de la tête de combustion
- Vérifiez les électrodes d'allumage et de détection, nettoyez-les, réglez-les si nécessaire et remplacez-les si besoin est. En cas de doute, contrôlez le circuit de détection, après avoir remis le brûleur en marche, en suivant le schéma.
- Nettoyage et graissage des leviers et des pièces rotatives



**ATTENTION** : si, au cours des opérations d'entretien, il est nécessaire de démonter les parties qui composent la rampe à gaz, ne pas oublier d'effectuer le test d'étanchéité une fois la rampe remontée, selon les modalités prévues par la réglementation en vigueur.

## Vérification du filtre en el MULTIBLOC DUNGS MB-DLE 405..412

- Vérification du filtre au moins une fois par an!
- Remplacement du filtre: si le  $\Delta p$  entre prise de pression 1 et 3 est  $> 10$  mbar.
- Remplacement du filtre: le  $\Delta p$  entre prise de pression 1 et 3 a doublé par rapport à la dernière mesure.

Le remplacement du filtre peut se réaliser sans démonter le MultiBloc.

- 1 Couper l'alimentation en gaz, fermer le robinet à boisseau sphérique.
- 2 Dévisser les vis 1, 2, 3, 4 avec une clé 6 pans mâle No 3. Oter le couvercle 5 du filtre (Fig. 1).
- 3 Remplacer l'élément filtrant 6 par un élément neuf.
- 4 Mise en place du couvercle 5 puis des vis 1, 2, 3, 4. Serrer avec modération.

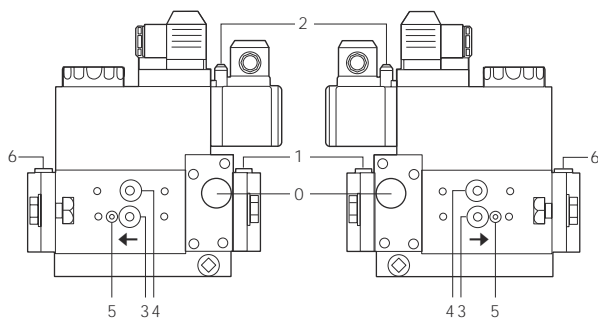

Fig. 37

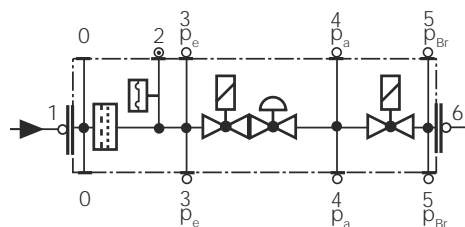

Fig. 38

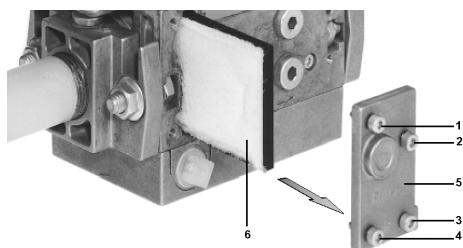

Fig. 39

## MULTIBLOC DUNGS MB-DLE 415 - 420 B01 1" 1/2 - 2"

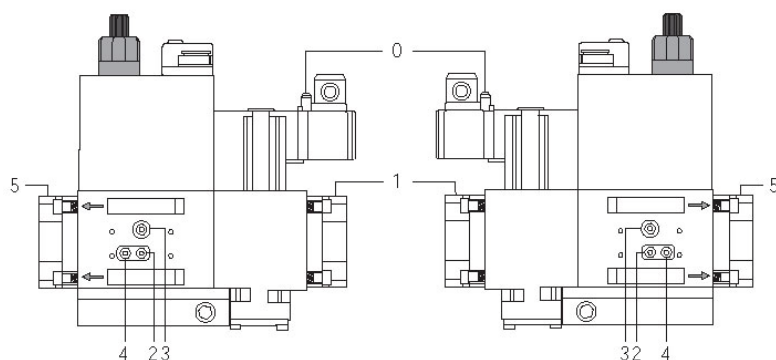

Fig. 40

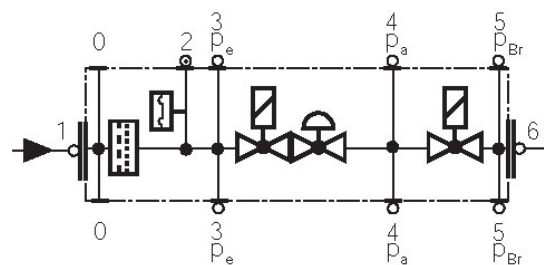

Fig. 41

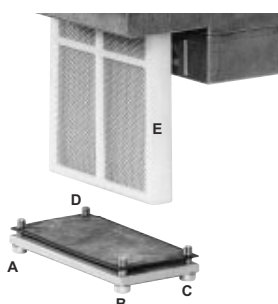

Fig. 42

### Dépose et nettoyage de la tête de combustion

- 1 Déverrouillez, à l'aide du crochet en plastique G, le tirant T pour le réglage du papillon des gaz et retirez-le de son logement en le tirant vers l'extérieur.
- 2 Retirez les 4 vis V1, V2, V3, V4 et la paire de vis S1 et S2
- 3 Débranchez le câble d'allumage CA du transformateur d'allumage
- 4 Débranchez le connecteur CR de la carte de circuit imprimé
- 5 Pour extraire la tête de combustion, tirez-la vers vous. Une fois extrait, vérifiez que les trous de passage de l'air et du gaz ne sont pas obstrués. Nettoyer la tête de combustion avec un jet d'air comprimé ou, en cas d'incrustations, avec une brosse en fer.

**ATTENTION :** Lors du remontage, installer les vis V1, V2, V3 et V4 sans les fixer ; remonter et fixer les vis S1 et S2 et enfin fixer les vis V1, V2, V3 et V4 .

**NOTE :** Les électrodes d'allumage et de détection sont contrôlées après le démontage de la tête de combustion.

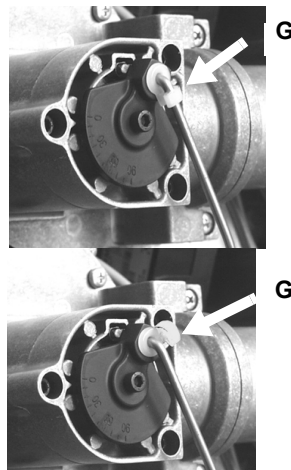
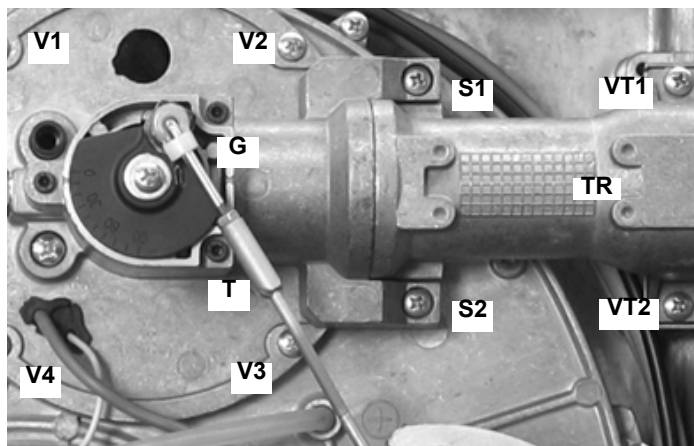

BLOCAGE

UNLOCKED

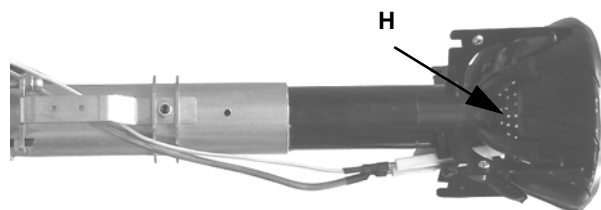
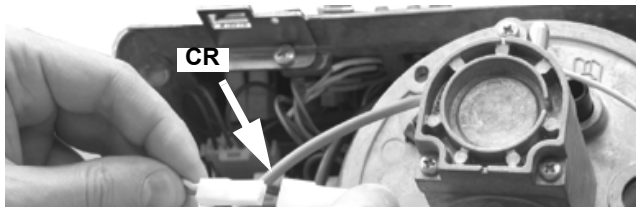

### Contrôle du courant de détection

Si le brûleur se bloque, effectuez les contrôles suivants. Pour mesurer le signal de détection, suivez le schéma de la . Si le signal est inférieur à la valeur indiquée, vérifier la position de l'électrode de détection, les contacts électriques et remplacer l'électrode de détection si nécessaire.

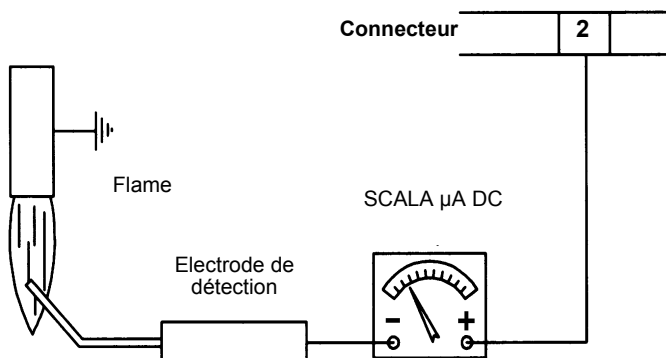

Équipement de contrôle de la flamme	Signal minimum détection
Siemens LME21-22	3 µA

## Surveillance des flammes avec QRA2 + ACQ3.1A27.. (juste pour LME2x ...)

Dispositif	Détection de la flamme	Mesure au détecteur UV QRA...
Siemens LME2x	QRA2	200 $\mu$ A

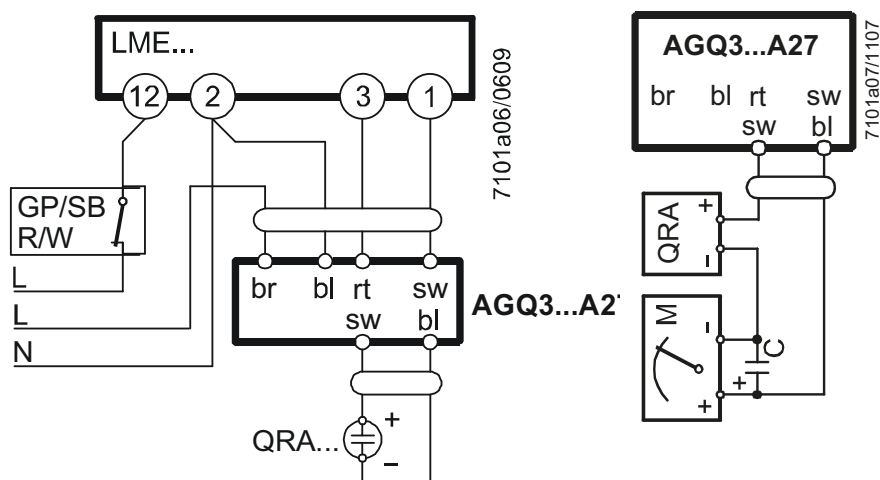

**AVERTISSEMENT :** Pour ne pas compromettre le fonctionnement du brûleur, éviter le contact des électrodes d'allumage et de détection avec les parties métalliques (tête, gicleur, etc.). Vérifiez la position des électrodes après chaque opération d'entretien de la tête de combustion.

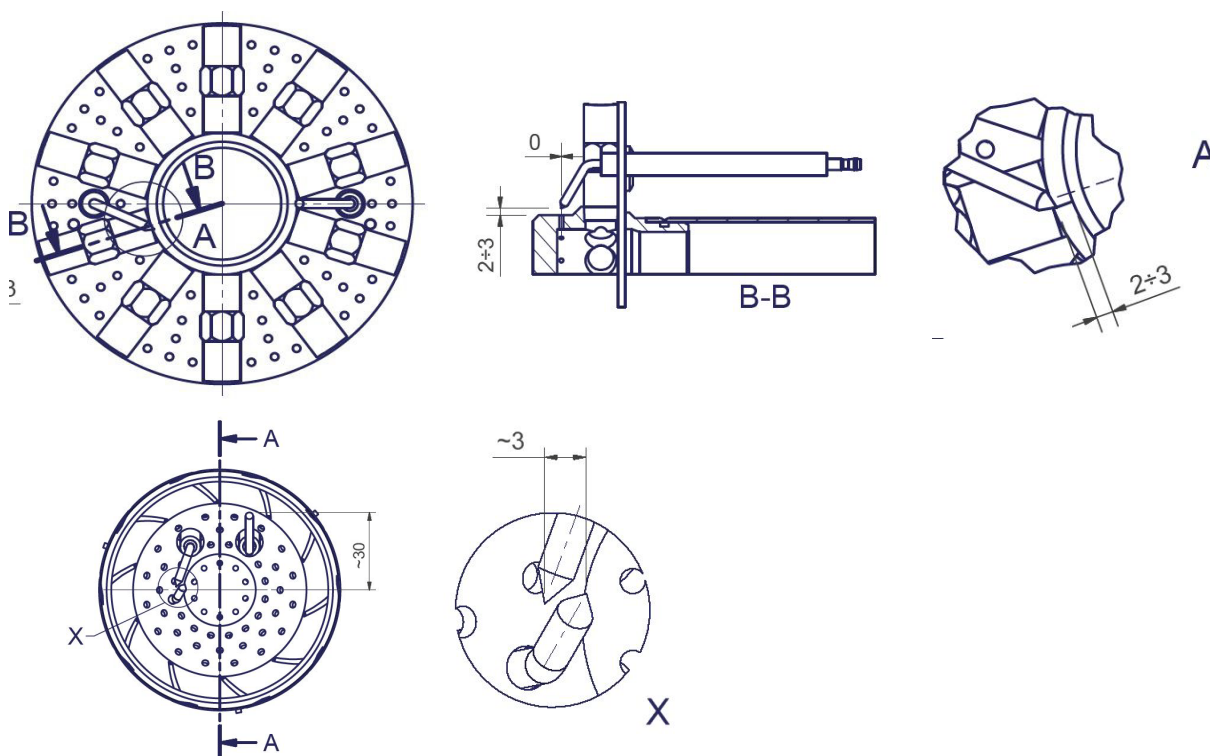

### Arrêt saisonnier

Procéder comme suit pour éteindre le brûleur durant l'arrêt saisonnier :

- 1 mettre l'interrupteur général du brûleur sur 0 (OFF - éteint)
- 2 débrancher la ligne d'alimentation électrique
- 3 fermer le robinet du combustible de la ligne de distribution.

### Démolition du brûleur

Lorsque le brûleur est devenu inutilisable, suivre les procédures prévues par les lois en vigueur sur l'élimination des déchets.

# TROUBLESHOOTING

CAUSE	TROUBLE												
	THE BURNER DOESN'T START	CONTINUE WITH PRE-PURGE	DOESN'T START AND LOCK-OUT	DOESN'T START AND REPEATS THE CYCLE	STARTS AND REPEATS THE CYCLE	STARTS AND LOCK-OUT	THE FLAME MONITOR DEVICE DOESN'T GIVE CONSENT TO START	DOESN'T SWITCH TO HIGH FLAME	DOESN'T RETURN IN LOW FLAME	THE SERVO CONTROL IS LOCK AND VIBRATE	LOCK-OUT DURING OPERATION	URNS OF AND REPEATS CYCLE DURING OPERATION	
MAIN SWITCH OPEN	●												
LACK OF GAS	●			●									
MAXIMUM GAS PRESSURE SWITCH DEFECTIVE (IF PROVIDED)	●		●										
THERMOSTATS/PRESSURE SWITCHES DEFECTIVE	●			●								●	
OVERLOAD TRIPPED INTERVENTION	●												
AUXILIARIES FUSE INTERRUPTED	●												
CONTROL BOX FAULTY	●	●	●			●					●		
DEFECTIVE SERVOCONTROL (IF PROVIDED)	●	●	●				♦						
AIR PRESSURE SWITCH FAULT OR BAD SETTING	●					●	●				●		
MINIMUM GAS PRESSURE SWITCH DEFECTIVE OR GAS FILTER DIRTY	●			●	●		●					●	
IGNITION TRANSFORMER FAULT			●										
IGNITION ELECTRODES BAD POSITION			●										
DETECTION ELECTRODE BAD POSITION						●					●		
BUTTERFLY VALVE BAD SETTING			●			●							
DEFECTIVE GAS GOVERNOR			●	●	●							●	
GAS VALVE DEFECTIVE			●										
BAD CONNECTION OR DEFECTIVE HIGH/LOW FLAME THERMOSTAT OR PRESSURE SWITCH (IF PROVIDED)							♦	●	●	♦			
WRONG SETTING SERVO CONTROL CAM							l	l	l				
UV PROBE DIRTY OR DEFECTIVE (IF PROVIDED)			l			l					l		
PHASE-NEUTRAL INVERTED						s							
PHASE-PHASE SUPPLY OR PRESENCE OF VOLTAGE ON THE NEUTRAL CONDUCTOR(*)						s							

l = with any control box;

s = with only LGB2../LMG2../LME11/LME2..

(\*) In such cases, insert the circuit SIEMENS "RC466890660" (See chapter "Electrical connections")

## WIRING DIAGRAMS

Wiring diagrams (see attached document)

LG/NG/NGX 280 Single stage - Electric wiring diagrams - SE01-530

LG/NG/NGX 280 Double stage - Progressive - Electric wiring diagrams - SE18-103

LG/NG/NGX 350-400 Electric wiring diagrams - SE18-163, SE18-057

# VERSIONE MONOSTADIO "TN" "TN" SINGLE-STAGE VERSION

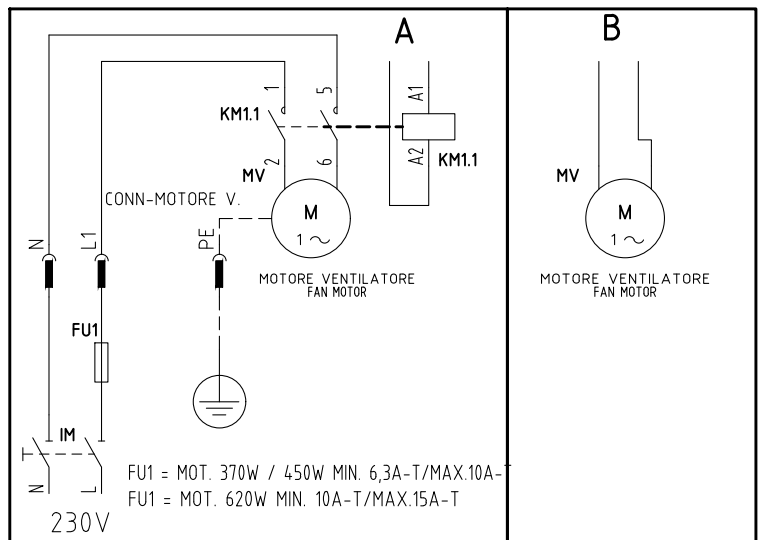
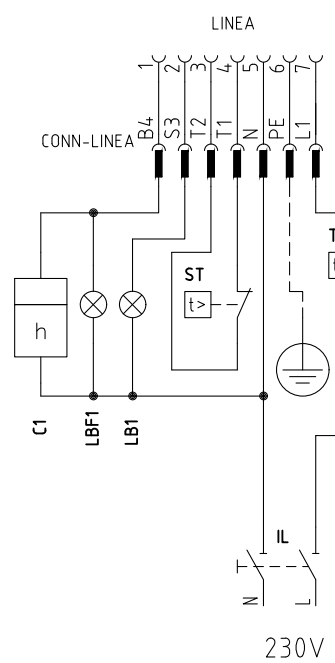
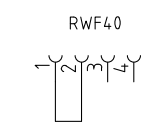
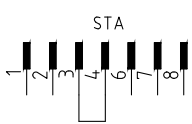
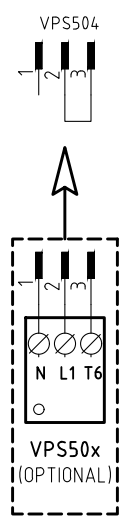
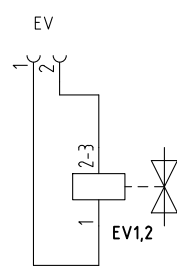
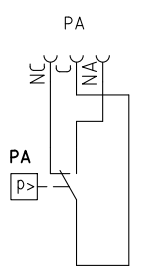
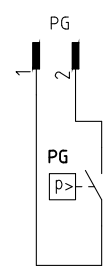
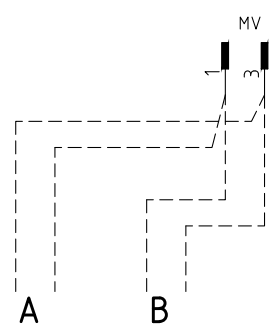
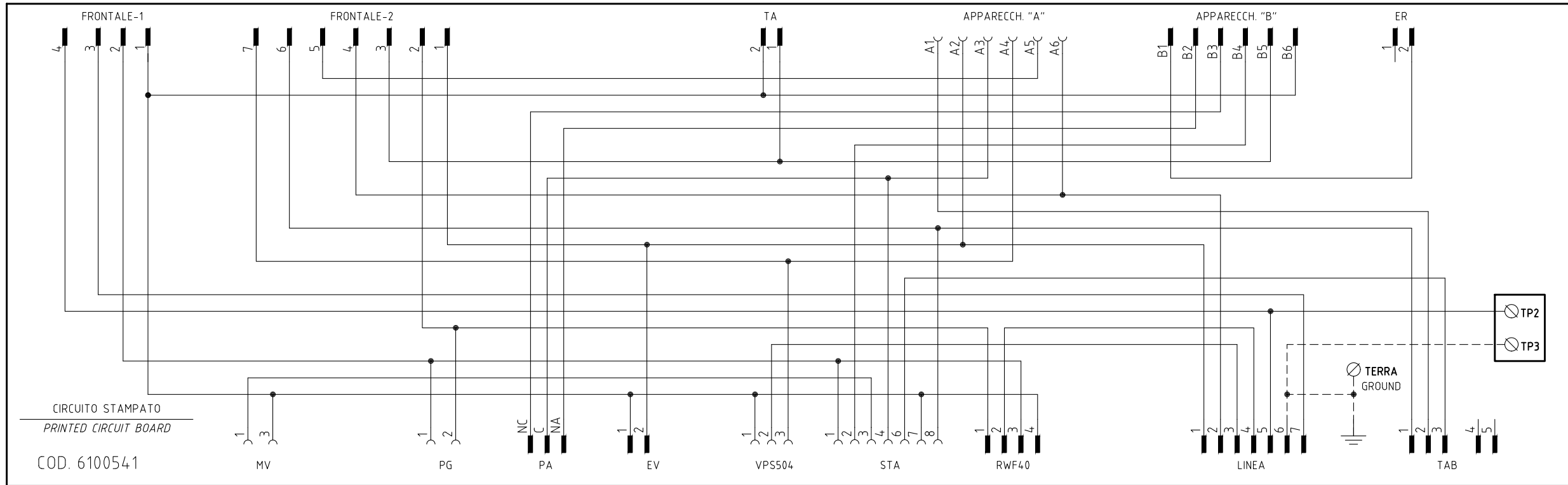
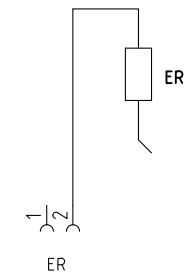
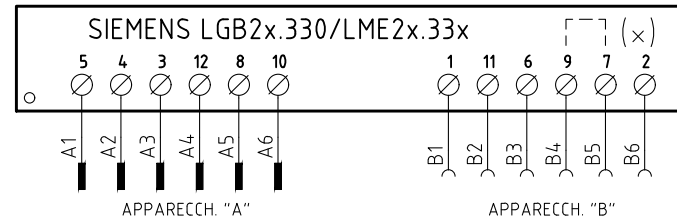
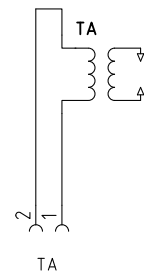
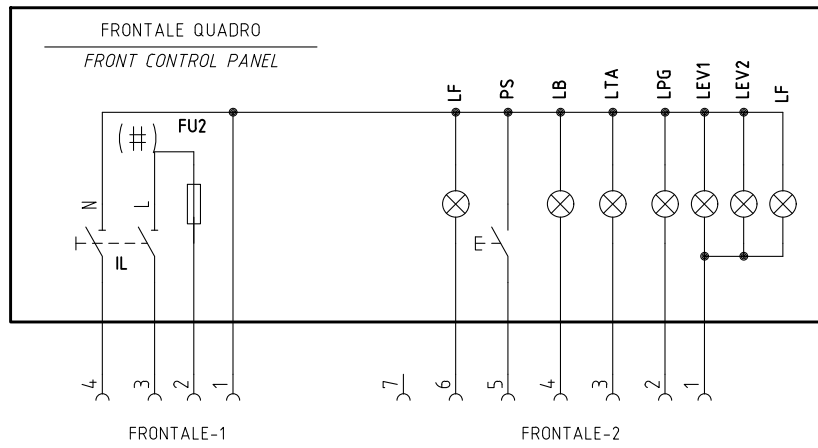

- (#) MOTORE VENTIL. VERSIONE [A], FU2 = 6,3A F; MOTORE VENTIL. VERSIONE [B], FU2 = 10A F  
FAN MOTOR VERSION [A], FU2= 6,3 A F;  
FAN MOTOR VERSION [B], FU2= 10 A F
- (x) FARE PONTE TRA I MORSETTI 7 E 9 SOLO CON LGB21.330  
CONNECTION BETWEEN TERMINALS 7 AND 9 WITH LGB21.330 ONLY
- (xxx) SOLO CON ALIMENTAZIONE ELETTRICA SENZA NEUTRO  
WITH ELECTRIC SUPPLY WITHOUT NEUTRAL VERSION ONLY

Data	19/10/2010	PREC.	FOGLIO
Revisione	06	/	1
Dis. N.	18 - 0163	SEGUE	TOTALE
		2	5

VERSIONE ALTA-BASSA FIAMMA "AB" / PROGRESSIVO "PR"  
 "AB" HIGH-LOW / "PR" PROGRESSIVE VERSION

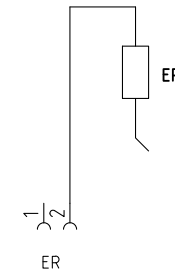
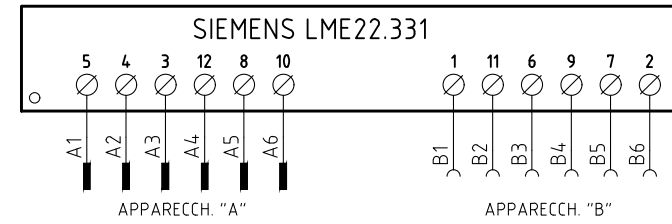
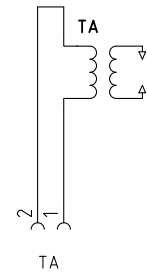
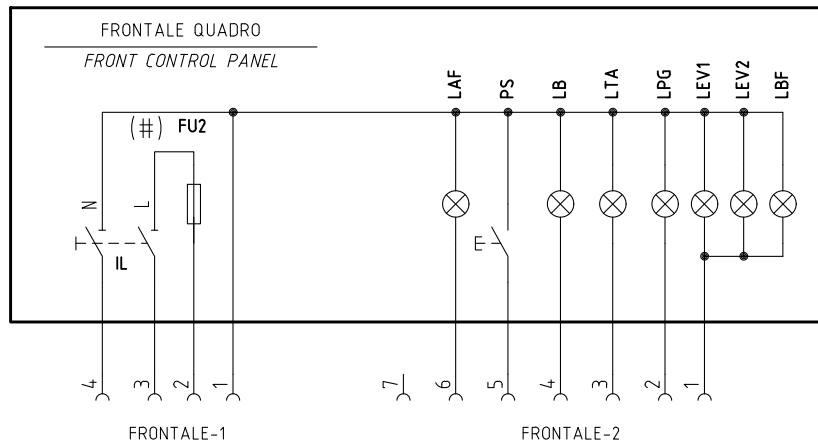

SERVOCOMANDO SERRANDA ARIA  
 AIR DAMPER ACTUATOR  
 STA13B0.36/83N30L  
 I ALTA FIAMMA  
 II HIGH FLAME  
 SOSTA  
 STAND-BY  
 III BASSA FIAMMA  
 IV LOW FLAME  
 NON USATA  
 NOT USED

SERVOCOMANDO SERRANDA ARIA  
 AIR DAMPER ACTUATOR  
 SIEMENS SQN72.xA4A20  
 I (ROSSO) ALTA FIAMMA  
 I (RED) HIGH FLAME  
 II (BLU) SOSTA  
 II (BLUE) STAND-BY  
 III (ARANCIO) BASSA FIAMMA  
 III (ORANGE) LOW FLAME  
 IV (NERO) NON USATA  
 IV (BLACK) NOT USED

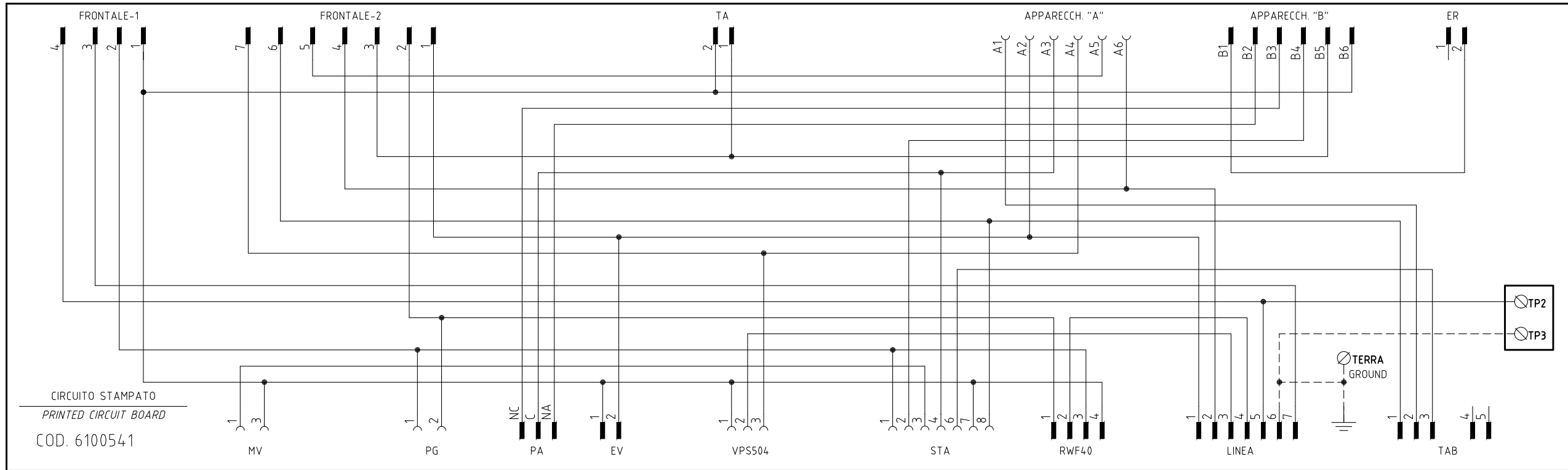

CIRCUITO STAMPATO  
 PRINTED CIRCUIT BOARD  
 COD. 6100541

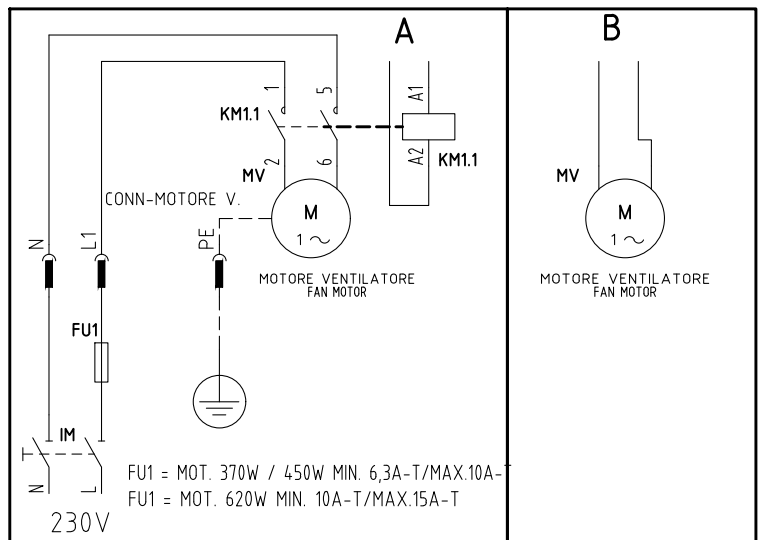
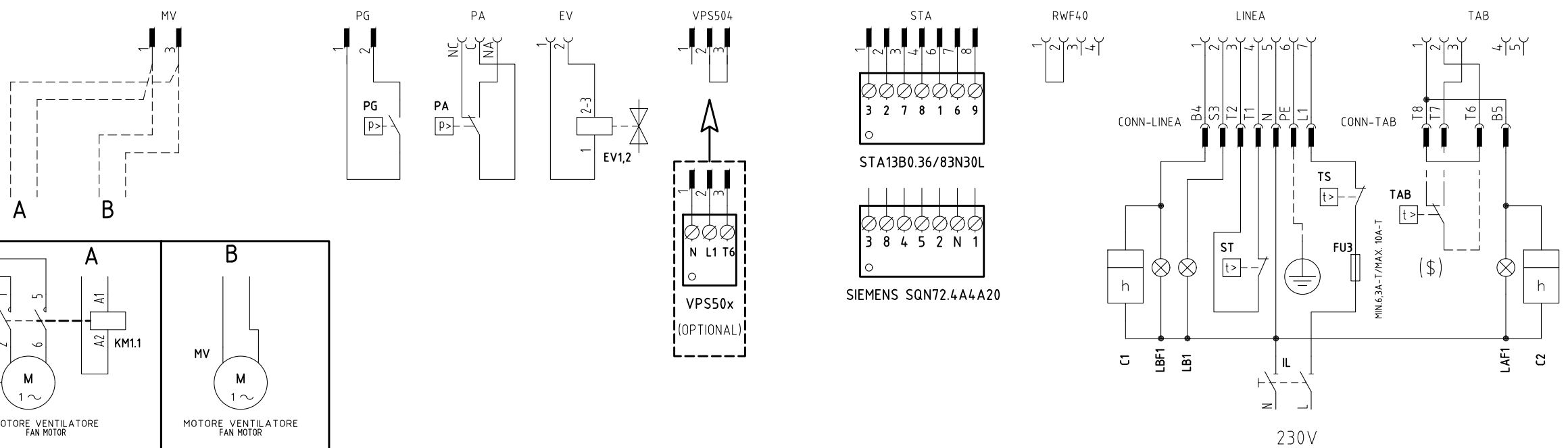

- (#) MOTORE VENTIL. VERSIONE [A], FU2 = 6,3A F; MOTORE VENTIL. VERSIONE [B], FU2 = 10A F  
 FAN MOTOR VERSION [A], FU2= 6,3 A F;  
 FAN MOTOR VERSION [B], FU2= 10 A F
- (x x x) SOLO CON ALIMENTAZIONE ELETTRICA SENZA NEUTRO  
 WITH ELECTRIC SUPPLY WITHOUT NEUTRAL VERSION ONLY
- (\$) SE USATO "TAB", TOGLIERE IL PONTE TRA I MORSETTI T6-T8  
 IF USED "TAB", REMOVE THE BRIDGE BETWEEN TERMINALS T6-T8

Data	19/10/2010	PREC.	FOGLIO
Revisione	06	1	2
Dis. N.	18 - 0163	3	5

VERSIONE MODULANTE "MD"  
"MD" MODULATING VERSION

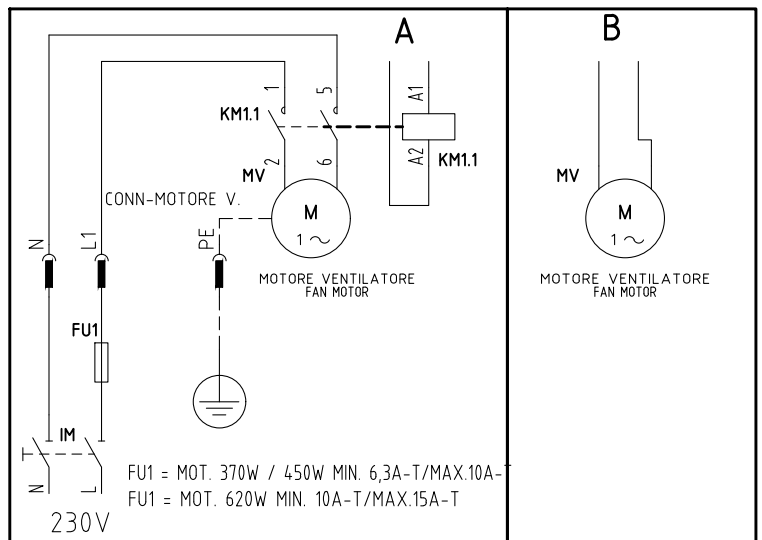
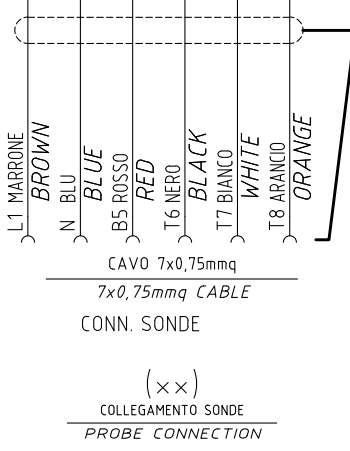
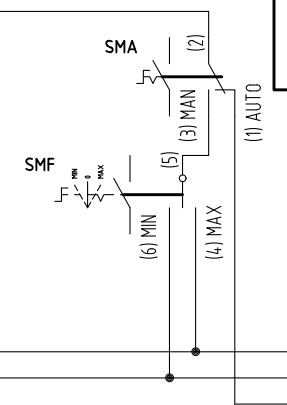
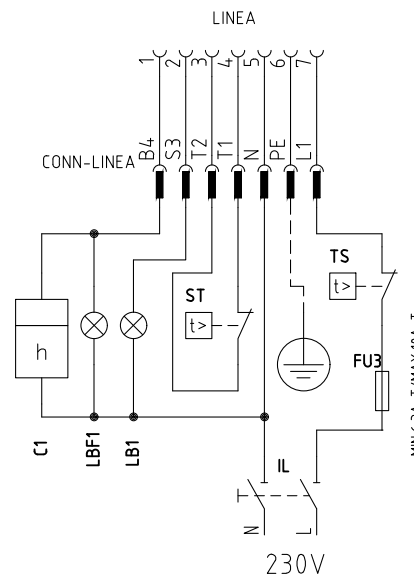
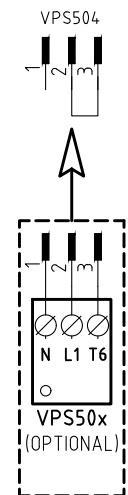
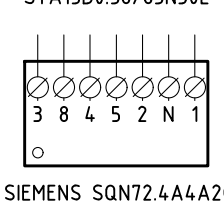
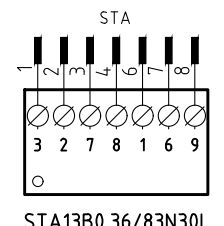
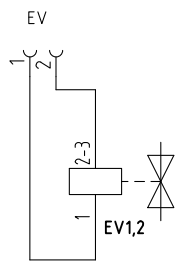
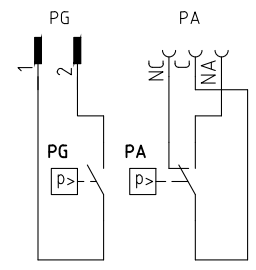
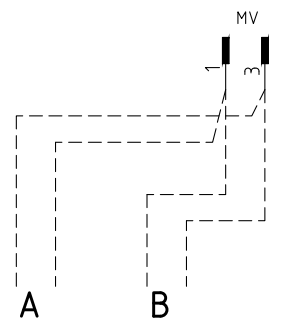
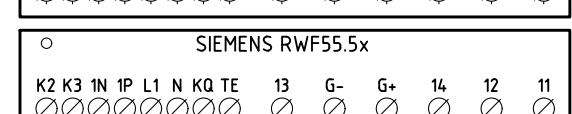
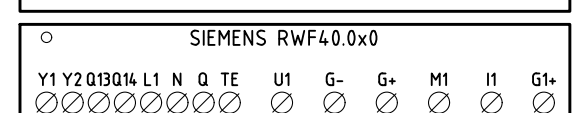
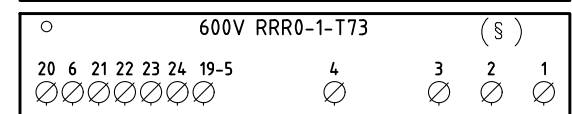
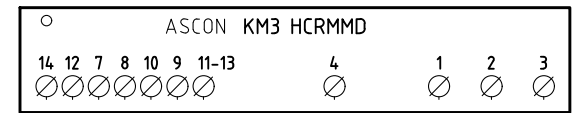
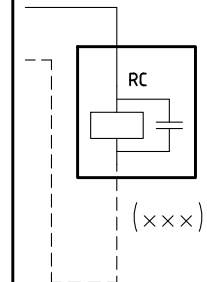
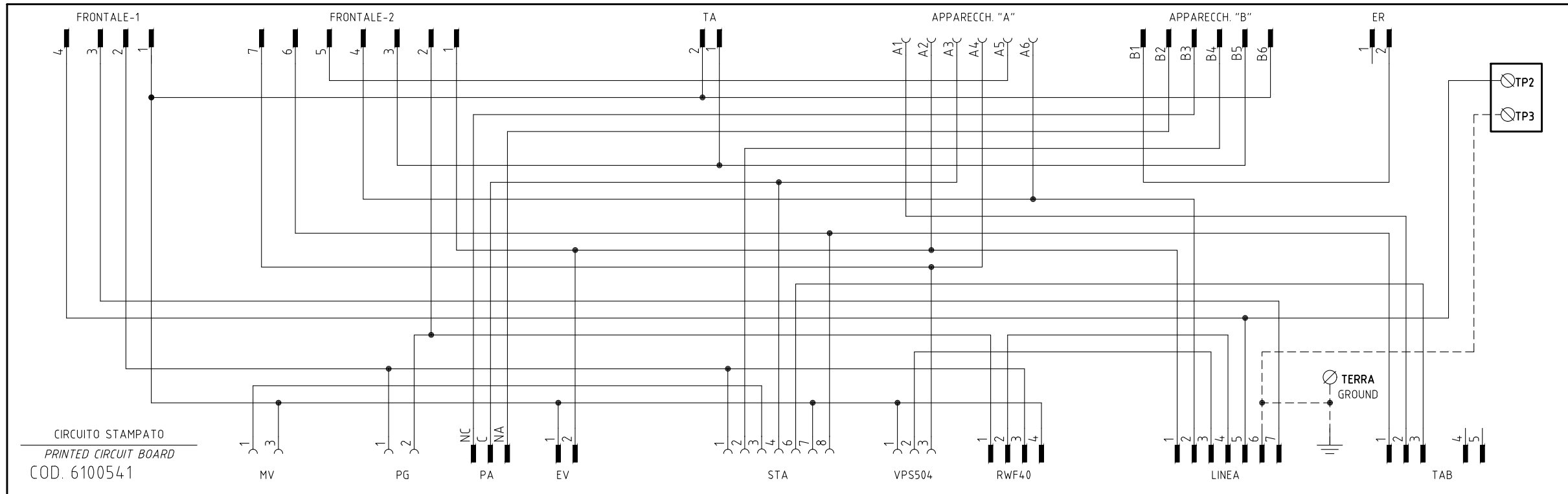
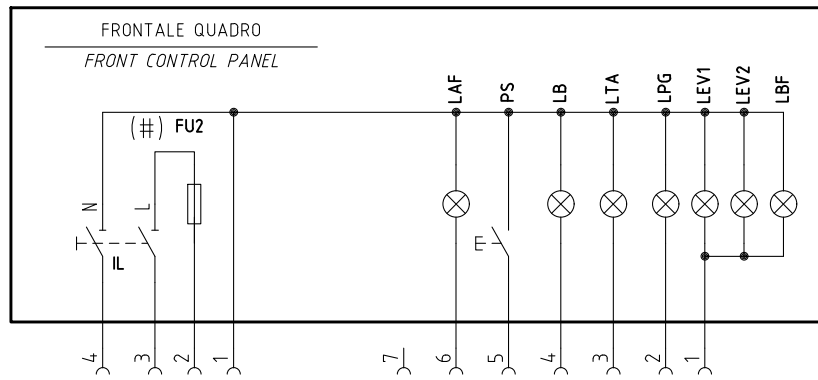

SERVOCOMANDO SERRANDA ARIA  
AIR DAMPER ACTUATOR  
STA13B0.36/83N30L  
I (ALTA FIAMMA / HIGH FLAME)  
II (SOSTA / STAND-BY)  
IV (BASSA FIAMMA / LOW FLAME)  
III (NON USATA / NOT USED)

SERVOCOMANDO SERRANDA ARIA  
AIR DAMPER ACTUATOR  
SIEMENS SQN72.xA4A20  
I (ROSSO) / ALTA FIAMMA / HIGH FLAME  
II (BLU) / SOSTA / STAND-BY  
III (ARANCIO) / BASSA FIAMMA / LOW FLAME  
IV (NERO) / NON USATA / NOT USED

(#) MOTORE VENTIL. VERSIONE [A], FU2 = 6,3A F; MOTORE VENTIL. VERSIONE [B], FU2 = 10A F  
FAN MOTOR VERSION [A], FU2= 6,3 A F;  
FAN MOTOR VERSION [B], FU2= 10 A F

(x x x) SOLO CON ALIMENTAZIONE ELETTRICA SENZA NEUTRO  
WITH ELECTRIC SUPPLY WITHOUT NEUTRAL VERSION ONLY

Data	19/10/2010	PREC.	FOGLIO
Revisione	06	2	3
Dis. N.	18 - 0163	SEGUE	TOTALE
		4	5

(xx)  
 ATTENZIONE COLLEGAMENTO SONDE CON CONNETTORE 7 POLI  
 WARNING PROBE CONNECTION WITH 7 PINS CONNECTOR

KM3 HCRMMD

600V RRR0-1-T73

RWF55.5x

RWF50.2x

RWF40.0xx

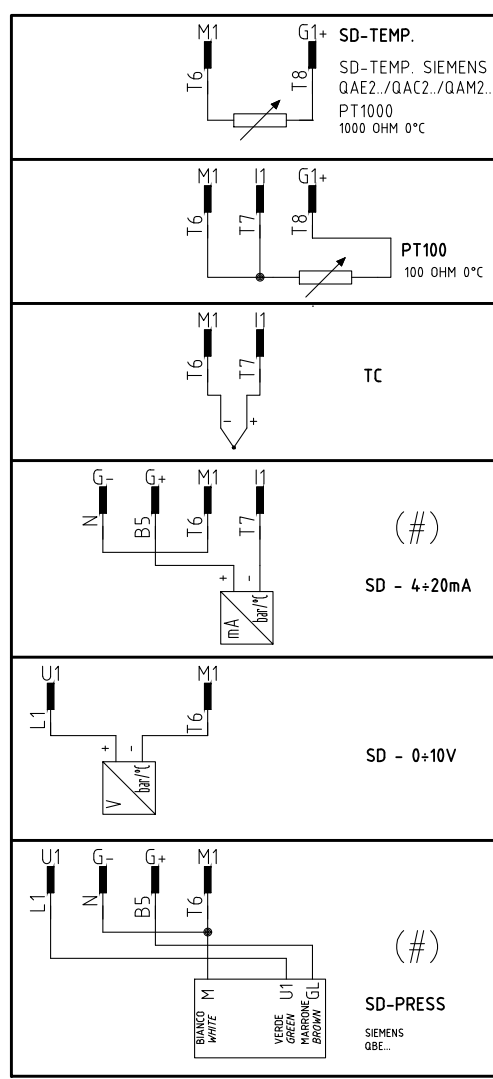
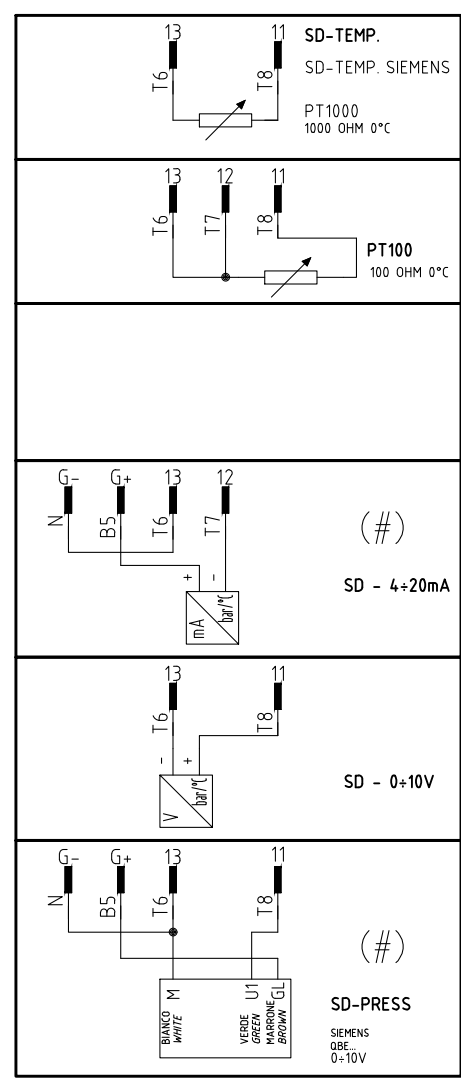
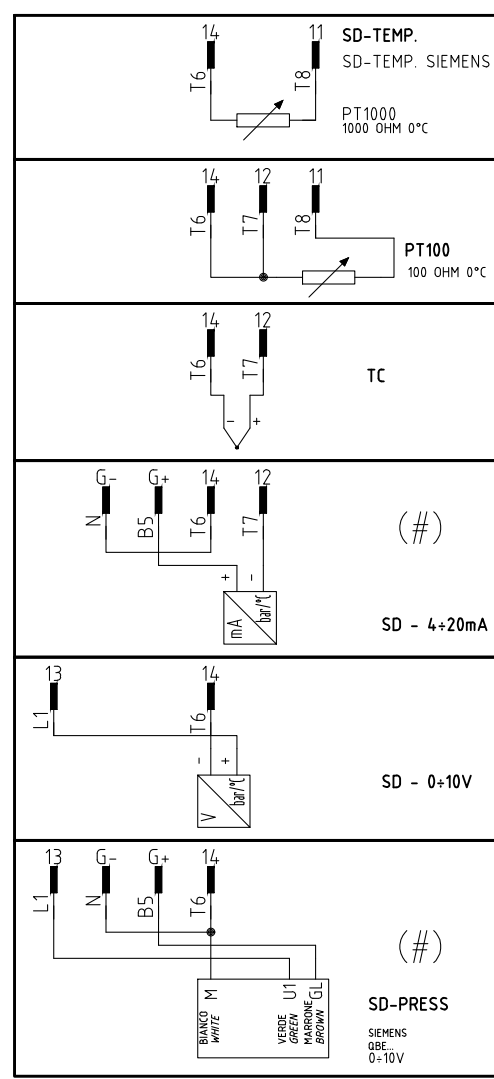
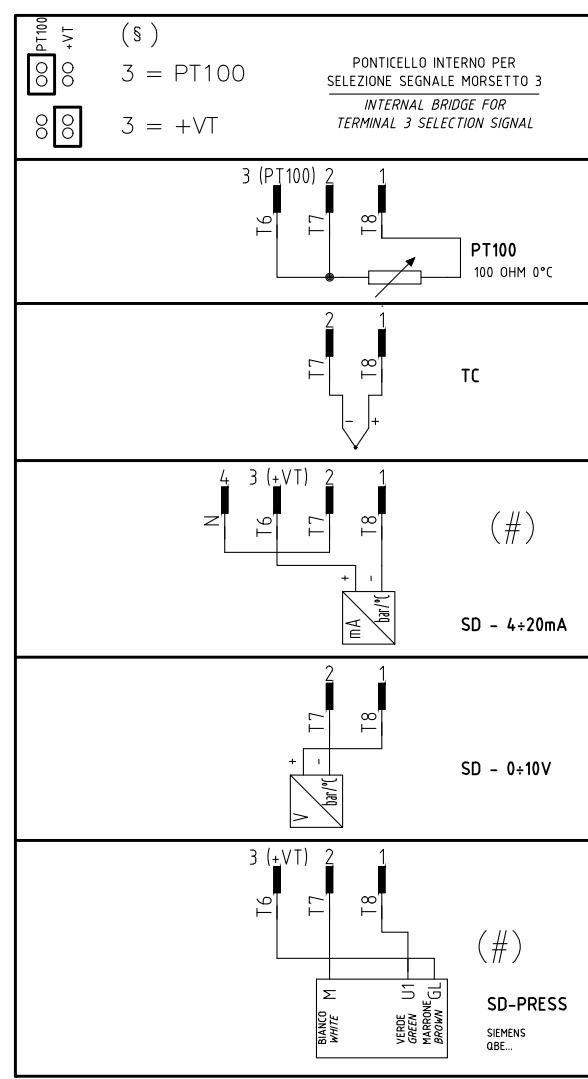
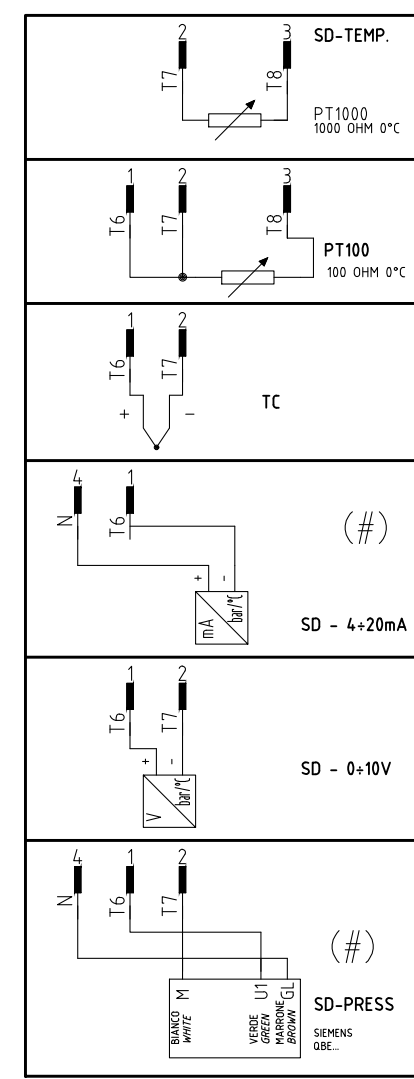

(#)  
 COLLEGAMENTO SOLO PER  
 TRASDUTTORI PASSIVI  
 TRANSDUCER PASSIVE  
 CONNECTION ONLY

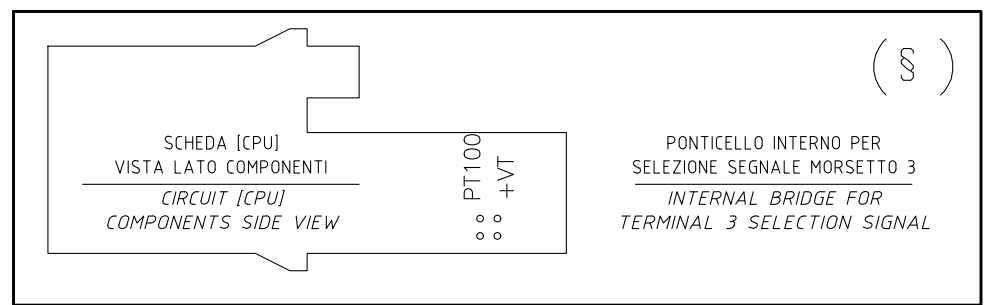
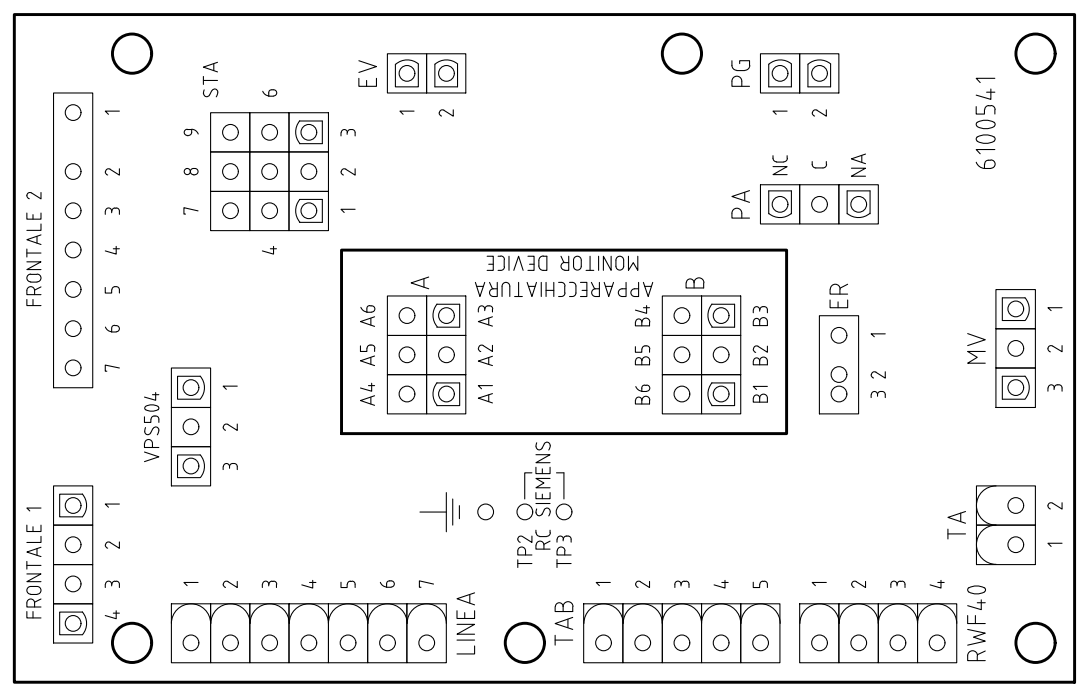

Data	19/10/2010	PREC.	FOGLIO
Revisione	06	3	4
Dis. N.	18 - 0163	SEGUE	TOTALE
		5	5

Sigla/Item	Funzione	Function
600V RRR0-1-T73	REGOLATORE MODULANTE (ALTERNATIVO)	BURNER MODULATOR (ALTERNATIVE)
C1	CONTAORE BASSA FIAMMA	LOW FLAME TIME COUNTER
C2	CONTAORE ALTA FIAMMA	HIGH FLAME TIME COUNTER
ER	ELETTRODO RILEVAZIONE FIAMMA	FLAME DETECTION ELECTRODE
EV1,2	ELETTROVALVOLE GAS (O GRUPPO VALVOLE)	GAS ELECTRO-VALVES (OR VALVES GROUP)
FU1	FUSIBILE LINEA MOTORE VENTILATORE	FAN MOTOR LINE FUSE
FU2	FUSIBILE DI LINEA	LINE FUSE
FU3	FUSIBILE LINEA BRUCIATORE	BURNER LINE FUSE
FU4	FUSIBILE AUSILIARIO	AUXILIARY FUSE
IL	INTERRUTTORE LINEA AUSILIARI	AUXILIARY LINE SWITCH
IM	INTERRUTTORE LINEA MOTORE VENTILATORE	FAN MOTOR LINE SWITCH
KM1.1	CONTATTORE MOTORE VENTILATORE	FAN MOTOR CONTACTOR
KM3 HCRMMD	REGOLATORE MODULANTE (ALTERNATIVO)	BURNER MODULATOR (ALTERNATIVE)
LAF	LAMPADA SEGNALAZIONE ALTA FIAMMA BRUCIATORE	BURNER IN HIGH FLAME INDICATOR LIGHT
LAF1	LAMPADA SEGNALAZIONE ALTA FIAMMA BRUCIATORE	BURNER IN HIGH FLAME INDICATOR LIGHT
LB	LAMPADA SEGNALAZIONE BLOCCO BRUCIATORE	INDICATOR LIGHT FOR BURNER LOCK-OUT
LB1	LAMPADA SEGNALAZIONE BLOCCO BRUCIATORE	INDICATOR LIGHT FOR BURNER LOCK-OUT
LBF	LAMPADA SEGNALAZIONE BASSA FIAMMA BRUCIATORE	BURNER IN LOW FLAME INDICATOR LIGHT
LBF1	LAMPADA SEGNALAZIONE BASSA FIAMMA BRUCIATORE	BURNER IN LOW FLAME INDICATOR LIGHT
LEV1	LAMPADA SEGNALAZIONE APERTURA [EV1]	INDICATOR LIGHT FOR OPENING OF ELECTRO-VALVE [EV1]
LEV2	LAMPADA SEGNALAZIONE APERTURA [EV2]	INDICATOR LIGHT FOR OPENING OF ELECTRO-VALVE [EV2]
LF	LAMPADA SEGNALAZIONE FUNZIONAMENTO BRUCIATORE	INDICATOR LIGHT BURNER OPERATION
LPG	LAMPADA SEGNALAZIONE PRESENZA GAS IN RETE	INDICATOR LIGHT FOR PRESENCE OF GAS IN THE NETWORK
LTA	LAMPADA SEGNALAZIONE TRASFORMATORE DI ACCENSIONE	IGNITION TRANSFORMER INDICATOR LIGHT
MV	MOTORE VENTILATORE	FAN MOTOR
PA	PRESSOSTATO ARIA	AIR PRESSURE SWITCH
PG	PRESSOSTATO GAS DI MINIMA PRESSIONE	MINIMUM GAS PRESSURE SWITCH
PS	PULSANTE SBLOCCO FIAMMA	FLAME UNLOCK BUTTON
PT100	SONDA DI TEMPERATURA	TEMPERATURE PROBE
RC	CIRCUITO RC	RC CIRCUIT
SD-PRESS	SONDA DI PRESSIONE	PRESSURE PROBE
SD-TEMP.	SONDA DI TEMPERATURA	TEMPERATURE PROBE
SD - 0÷10V	TRASDUTTORE USCITA IN TENSIONE	TRANSDUCER VOLTAGE OUTPUT
SD - 4÷20mA	TRASDUTTORE USCITA IN CORRENTE	TRANSDUCER CURRENT OUTPUT
SIEMENS LGB2x.330/LME2x.33x	APPARECCHIATURA CONTROLLO FIAMMA	CONTROL BOX
SIEMENS LME22.331	APPARECCHIATURA CONTROLLO FIAMMA	CONTROL BOX
SIEMENS LME22.331	APPARECCHIATURA CONTROLLO FIAMMA	CONTROL BOX
SIEMENS RWF40.0x0	REGOLATORE MODULANTE	BURNER MODULATOR
SIEMENS RWF50.2x	REGOLATORE MODULANTE	BURNER MODULATOR
SIEMENS RWF55.5x	REGOLATORE MODULANTE (ALTERNATIVO)	BURNER MODULATOR (ALTERNATIVE)
SIEMENS SQN72.4A4A20	SERVOCOMANDO SERRANDA ARIA (ALTERNATIVO)	AIR DAMPER ACTUATOR (ALTERNATIVE)
SMA	SELETTORE MANUALE/AUTOMATICO	MANUAL/AUTOMATIC SWITCH
SMF	SELETTORE MANUALE FUNZIONAMENTO MIN-0-MAX	MIN-0-MAX MANUAL OPERATION SWITCH
ST	SERIE TERMOSTATI/PRESSOSTATI	SERIES OF THERMOSTATS OR PRESSURE SWITCHES
STA13B0.36/83N30L	SERVOCOMANDO SERRANDA ARIA	AIR DAMPER ACTUATOR
TA	TRASFORMATORE DI ACCENSIONE	IGNITION TRANSFORMER
TAB	TERMOSTATO/PRESSOSTATO ALTA-BASSA FIAMMA	HIGH-LOW THERMOSTAT/PRESSURE SWITCHES
TC	TERMOCOPPIA	THERMOCOUPLE
TS	TERMOSTATO/PRESSOSTATO DI SICUREZZA	SAFETY THERMOSTAT OR PRESSURE SWITCH
VPS50x	CONTROLLO DI TENUTA VALVOLE GAS (OPTIONAL)	GAS PROVING SYSTEM (OPTIONAL)

Data	19/10/2010	PREC.	FOGLIO
Revisione	06	4	5
Dis. N.	18 - 0163	SEGUE	TOTALE
		/	5

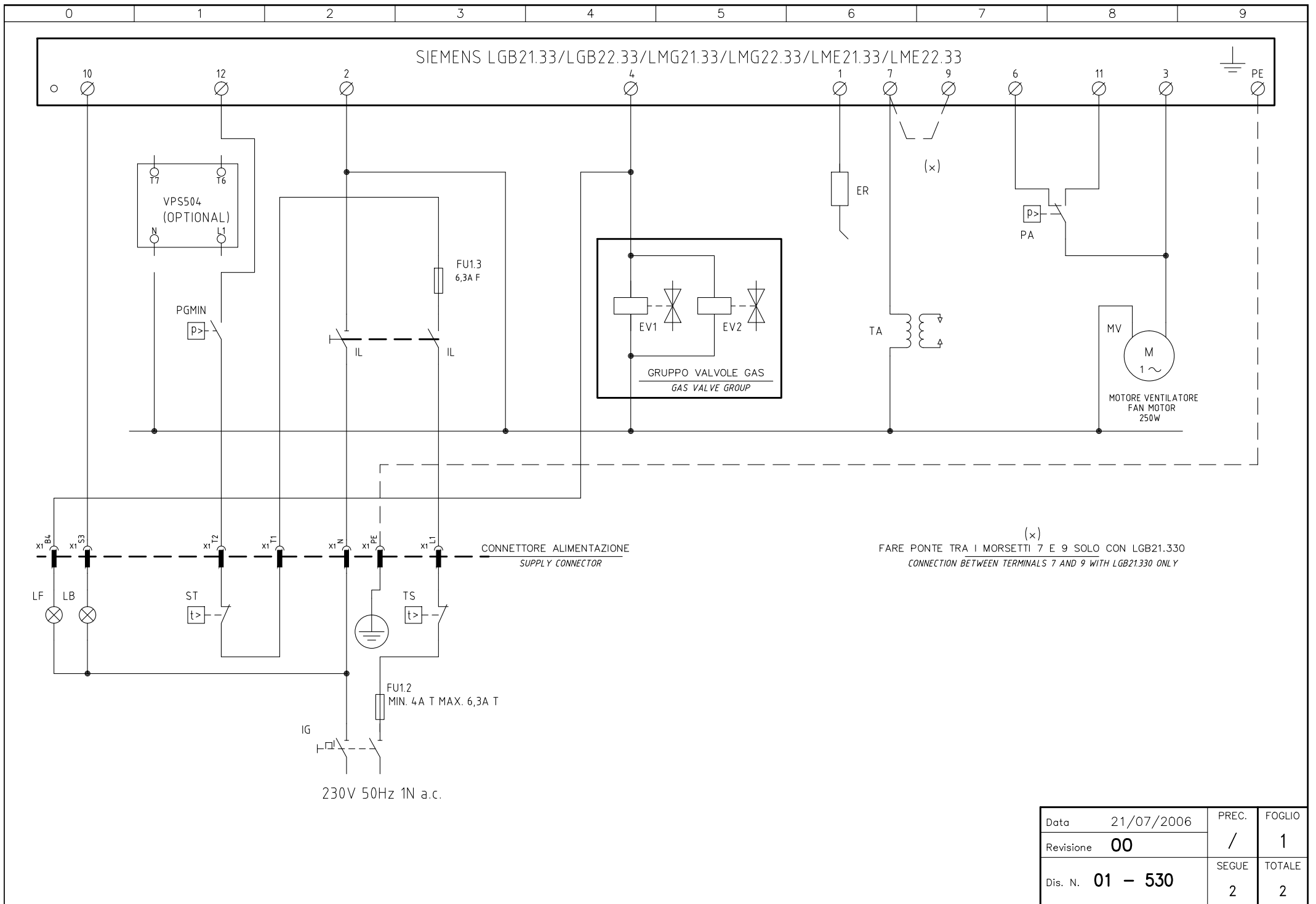

Data	21/07/2006	PREC.	FOGLIO
Revisione	00	/	1
Dis. N.	01 - 530	SEGUE	TOTALE
		2	2

SIGLA/ITEM	FOGLIO/SHEET	FUNZIONE	FUNCTION
ER	1	ELETTRODO RIVELAZIONE FIAMMA	FLAME DETECTION ELECTRODE
EV1	1	ELETTROVALVOLA GAS LATO RETE (O GRUPPO VALVOLE)	GAS ELECTRO-VALVE UPSTREAM (OR VALVES GROUP)
EV2	1	ELETTROVALVOLA GAS LATO BRUCIATORE (O GRUPPO VALVOLE)	GAS ELECTRO-VALVE DOWNSTREAM (OR VALVES GROUP)
FU1.2	1	FUSIBILE DI LINEA	LINE FUSE
FU1.3	1	FUSIBILE AUSILIARIO	AUXILIARY FUSE
IG	1	INTERRUTTORE GENERALE	MAIN DISCONNECTOR
IL	1	INTERRUTTORE LINEA BRUCIATORE	BURNER LINE SWITCH
LB	1	LAMPADA SEGNALAZIONE BLOCCO BRUCIATORE	INDICATOR LIGHT FOR BURNER LOCK-OUT
LF	1	LAMPADA SEGNALAZIONE FUNZIONAMENTO BRUCIATORE	INDICATOR LIGHT BURNER OPERATION
MV	1	MOTORE VENTILATORE	FAN MOTOR
PA	1	PRESSOSTATO ARIA COMBURENTE	COMBUSTION AIR PRESSURE SWITCH
PGMIN	1	PRESSOSTATO GAS DI MINIMA PRESSIONE	MINIMUM GAS PRESSURE SWITCH
SIEMENS LGB../LMG../LME..	1	APPARECCHIATURA CONTROLLO FIAMMA	FLAME MONITOR DEVICE
ST	1	SERIE TERMOSTATI/PRESSOSTATI	SERIES OF THERMOSTATS OR PRESSURE SWITCHES
TA	1	TRASFORMATORE DI ACCENSIONE	IGNITION TRANSFORMER
TS	1	TERMOSTATO/PRESSOSTATO DI SICUREZZA	SAFETY THERMOSTAT OR PRESSURE SWITCH
VPS504	1	CONTROLLO DI TENUTA VALVOLE GAS (OPTIONAL)	GAS LEAKAGE MONITOR DEVICE (OPTIONAL)

Data	21/07/2006	PREC.	FOGLIO
Revisione	00	1	2
Dis. N.	01 - 530	SEGUE	TOTALE
		/	2

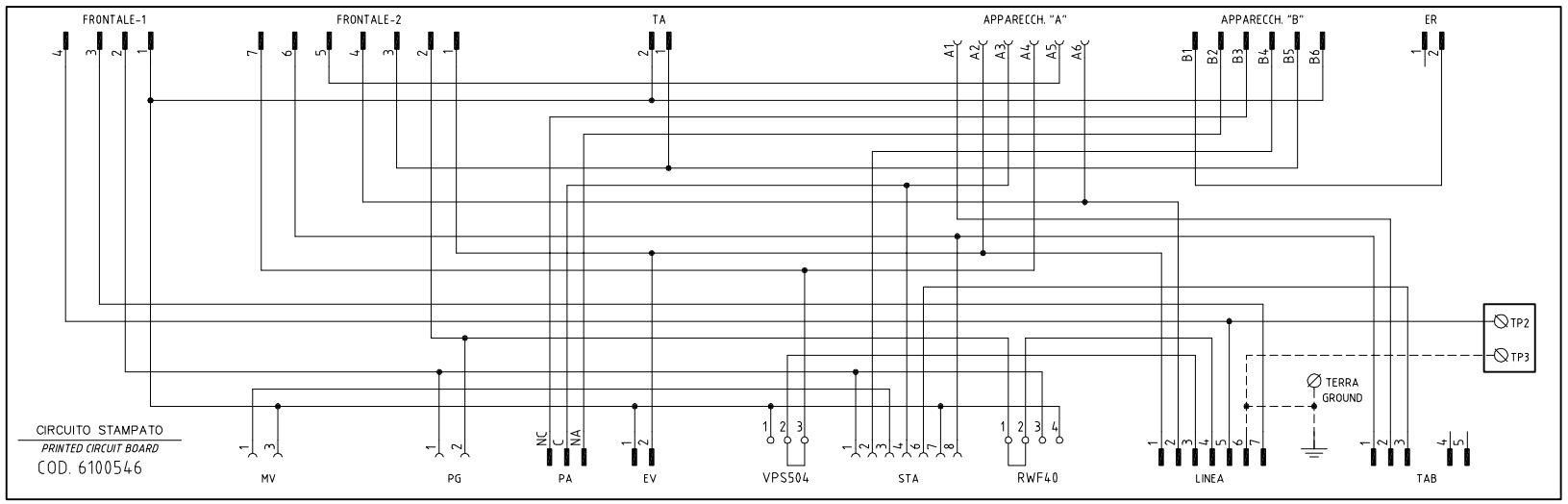
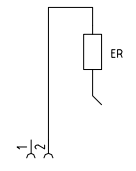
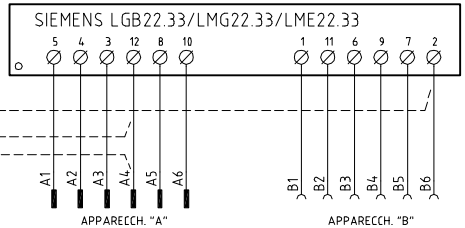
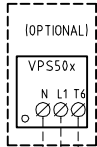
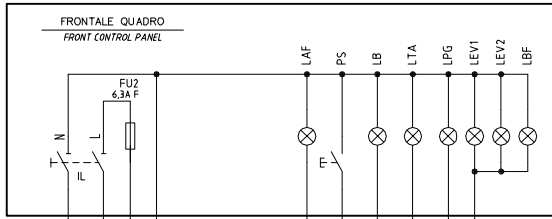

CAMME SERVOCOMANDO SERRANDA ARIA VERSIONE IAB)  
 CAMS OF AIR DAMPER ACTUATOR VERSION IAB)  
 STA4.5B0.37/63N30L / STA13B0.36/83N30L

- I ALTA FIAMMA HIGH FLAME
- II SOSTA STAND-BY
- IV BASSA FIAMMA LOW FLAME
- III (ARANCIO) NON USATA NOT USED

CAMME SERVOCOMANDO SERRANDA ARIA VERSIONE IPR)  
 CAMS OF AIR DAMPER ACTUATOR VERSION IPR)  
 SQN72.xA4A20

- I (ROSSO) ALTA FIAMMA HIGH FLAME
- II (VERDE) SOSTA STAND-BY
- III (BLAU) BASSA FIAMMA LOW FLAME
- IV (NERO) NON USATA NOT USED

CIRCUITO STAMPATO  
 PRINTED CIRCUIT BOARD  
 COD. 6100546

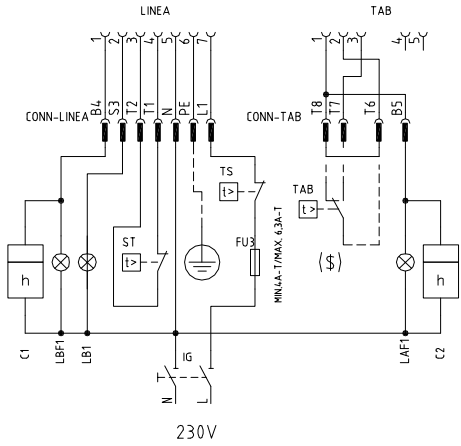
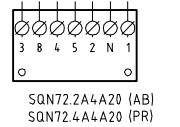
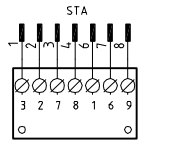
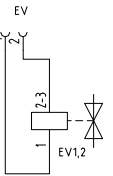
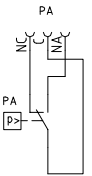
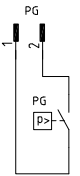
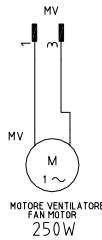

(xxx) SOLO CON ALIMENTAZIONE ELETTRICA SENZA NEUTRO  
 WITH ELECTRIC SUPPLY WITHOUT NEUTRAL VERSION ONLY

(\$) SE USATO "TAB", TOGLIERE IL PONTE TRA I MORSETTI T6-T8  
 IF USED "TAB", REMOVE THE BRIDGE BETWEEN TERMINALS T6-T8

Data	21/07/2006	PREC.	FOGLIO
Revisione	01	/	1
Dis. N.	18 - 103	SEQUE	TOTALE
		2	2

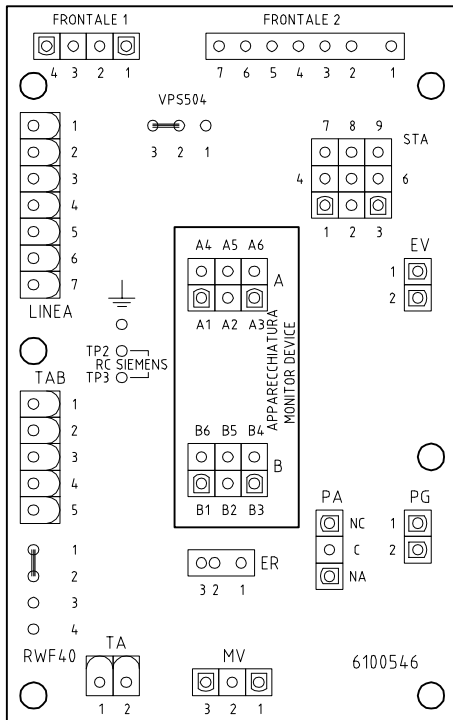

SIGLA/ITEM	FUNZIONE	FUNCTION
C1	CONTAORE BASSA FIAMMA	LOW FLAME TIME COUNTER
C2	CONTAORE ALTA FIAMMA	HIGH FLAME TIME COUNTER
ER	ELETTRODO RILEVAZIONE FIAMMA	FLAME DETECTION ELECTRODE
EV1,2	ELETTROVALVOLE GAS (O GRUPPO VALVOLE)	GAS ELECTRO-VALVES (OR VALVES GROUP)
FU2	FUSIBILE DI LINEA	LINE FUSE
FU3	FUSIBILE LINEA BRUCIATORE	BURNER LINE FUSE
IG	INTERRUTTORE LINEA BRUCIATORE	BURNER LINE SWITCH
IL	INTERRUTTORE LINEA AUSILIARI	AUXILIARY LINE SWITCH
LAF	LAMPADA SEGNALAZIONE ALTA FIAMMA BRUCIATORE	BURNER IN HIGH FLAME INDICATOR LIGHT
LAF1	LAMPADA SEGNALAZIONE ALTA FIAMMA BRUCIATORE	BURNER IN HIGH FLAME INDICATOR LIGHT
LB	LAMPADA SEGNALAZIONE BLOCCO BRUCIATORE	INDICATOR LIGHT FOR BURNER LOCK-OUT
LB1	LAMPADA SEGNALAZIONE BLOCCO BRUCIATORE	INDICATOR LIGHT FOR BURNER LOCK-OUT
LBF	LAMPADA SEGNALAZIONE BASSA FIAMMA BRUCIATORE	BURNER IN LOW FLAME INDICATOR LIGHT
LBF1	LAMPADA SEGNALAZIONE BASSA FIAMMA BRUCIATORE	BURNER IN LOW FLAME INDICATOR LIGHT
LEV1	LAMPADA SEGNALAZIONE APERTURA [EV1]	INDICATOR LIGHT FOR OPENING OF ELECTRO-VALVE [EV1]
LEV2	LAMPADA SEGNALAZIONE APERTURA [EV2]	INDICATOR LIGHT FOR OPENING OF ELECTRO-VALVE [EV2]
LPG	LAMPADA SEGNALAZIONE PRESENZA GAS IN RETE	INDICATOR LIGHT FOR PRESENCE OF GAS IN THE NETWORK
LTA	LAMPADA SEGNALAZIONE TRASFORMATORE DI ACCENSIONE	IGNITION TRANSFORMER INDICATOR LIGHT
MV	MOTORE VENTILATORE	FAN MOTOR
PA	PRESSOSTATO ARIA	AIR PRESSURE SWITCH
PG	PRESSOSTATO GAS DI MINIMA PRESSIONE	MINIMUM GAS PRESSURE SWITCH
PS	PULSANTE SBLOCCO FIAMMA	LOCK-OUT RESET BUTTON
RC	CIRCUITO RC	RC CIRCUIT
SIEMENS LGB22.33/LMG22.33/LME22.33	APPARECCHIATURA CONTROLLO FIAMMA	CONTROL BOX
SQN72.2A4A20	SERVOCOMANDO SERRANDA ARIA VERSIONE [AB]	AIR DAMPER ACTUATOR VERSION [AB]
SQN72.4A4A20	SERVOCOMANDO SERRANDA ARIA VERSIONE [PR]	AIR DAMPER ACTUATOR VERSION [PR]
ST	SERIE TERMOSTATI/PRESSOSTATI	SERIES OF THERMOSTATS OR PRESSURE SWITCHES
STA4.5B0.37/63N30L	SERVOCOMANDO SERRANDA ARIA VERSIONE [AB]	AIR DAMPER ACTUATOR VERSION [AB]
STA13B0.36/83N30L	SERVOCOMANDO SERRANDA ARIA VERSIONE [PR]	AIR DAMPER ACTUATOR VERSION [PR]
TA	TRASFORMATORE DI ACCENSIONE	IGNITION TRANSFORMER
TAB	TERMOSTATO/PRESSOSTATO ALTA-BASSA FIAMMA	HIGH-LOW THERMOSTAT/PRESSURE SWITCHES
TS	TERMOSTATO/PRESSOSTATO DI SICUREZZA	SAFETY THERMOSTAT OR PRESSURE SWITCH
VPS50x	CONTROLLO DI TENUTA VALVOLE GAS (OPTIONAL)	GAS PROVING SYSTEM (OPTIONAL)

Data	21/07/2006	PREC.	FOGLIO
Revisione	01	1	2
Dis. N.	18 - 103	SEQUE	TOTALE
		/	2

**BURNER EXPLODED VIEW NG280**

Position	Description
1	VALVE GROUP
3	COVER FIXING SCREW
7	FIXING BRACKET - LEFT SIDE
8	FIXING BRACKET - RIGHT SIDE
10	COVER
11	4-WAYS FAIRLEAD
12	2-WAYS FAIRLEAD
13	FAIRLEAD
14	FASTENER
15.1	GAS PRESSURE INTAKE
15.2	HOUSING
15.3	FLANGED COUPLING
15.4	MOTOR'S PLATE
15.5	WASHER
16	GASKET
17	AIR DAMPER INDEX
18	EXTENSION SCREW
19	FAN
20	GAS PRESSURE SWITCH
21	MOTOR
22	VALVE GROUP FLANGE
23	GAS PROVING SYSTEM
25	AIR FLAP
26	AIR DAMPER CRANK (progressive and fully modulating only)
27	FIXING ROD
30	PANEL ASSEMBLY
34	GREY/GREEN TERMINAL
35	BLACK/GREEN TERMINAL
36	BLOCKING PLATE
37.1	COMPONENTS BRACKET
37.2	ELECTRONIC BOARD
37.3	ACTUATOR (double stage, progressive and fully modulating only)
37.4	AIR PRESSURE SWITCH
37.5	CONTROL BOX BOARD
37.6	CONTROL BOX
37.7	GAS TRANSFORMER
38	BOX ASSEMBLY
41	BLAST TUBE
42.1	BUTTERFLY MANIFOLD
42.12	IGNITION CABLE
42.13	DETECTION CABLE
42.17.1	IGNITION ELECTRODE
42.17.2	DETECTION ELECTRODE
42.17.3	GROUNDING CABLE
42.17.5	COMBUSTION HEAD
43	GAS PIPE
44	OR RING

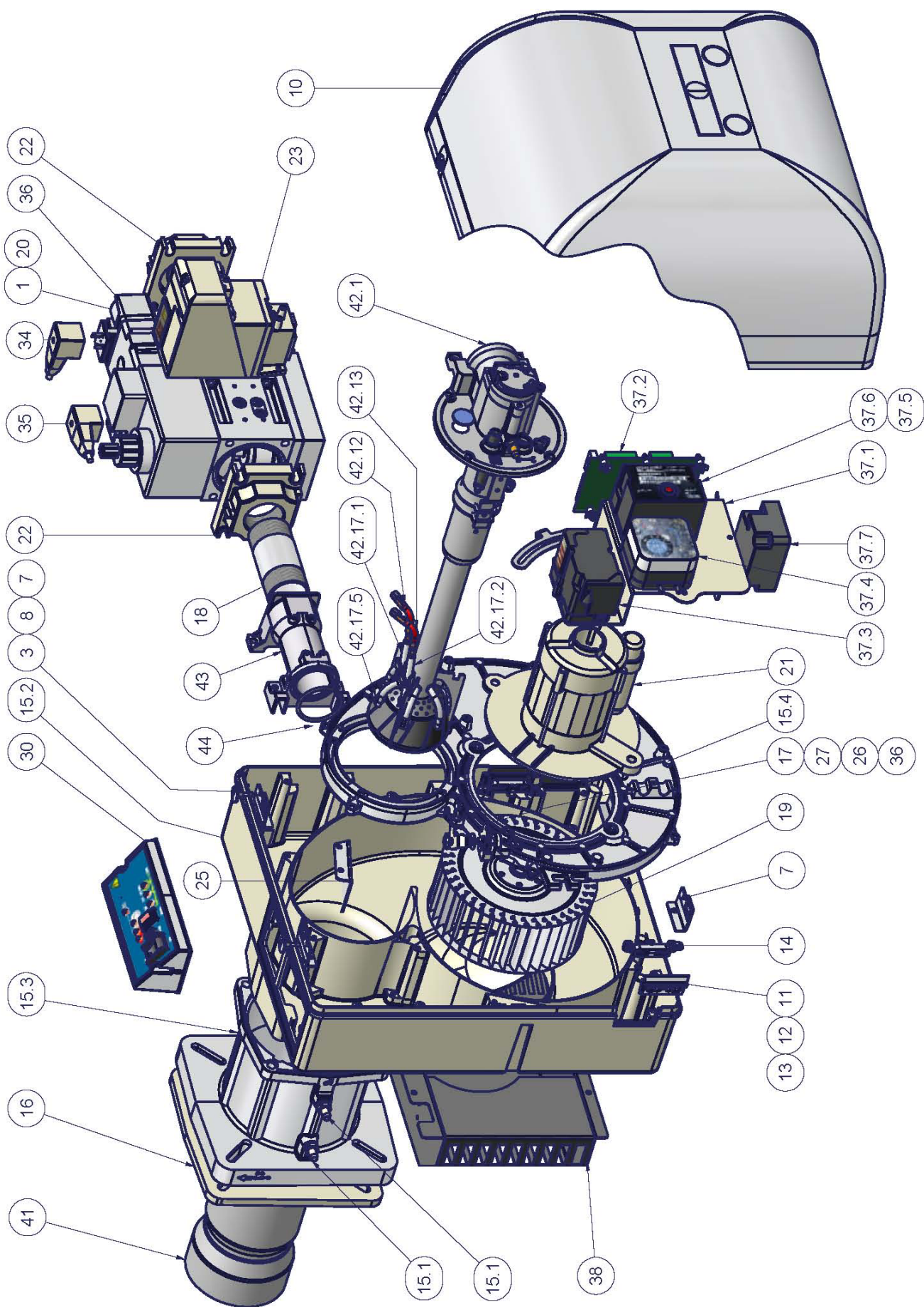



**BURNER EXPLODED VIEW NG350-400**

Position	Description
1	VALVE GROUP
2	WASHER
3	COVER FIXING SCREW
4	AIR DAMPER ASSEMBLY
5	BOX ASSEMBLY
6	BOARD'S SUPPORTING BRACKET
7	FIXING BRACKET - LEFT SIDE
8	FIXING BRACKET - RIGHT SIDE
9	BLAST TUBE
10	COVER
11	4-WAYS FAIRLEAD
12	2-WAYS FAIRLEAD
13	FAIRLEAD
14	FASTENER
15.1	GAS PRESSURE INTAKE
15.2	HOUSING
15.3	FLANGED COUPLING
15.4	MOTOR'S PLATE
15.5	WASHER
16	GASKET
17	AIR DAMPER INDEX
18	EXTENSION SCREW
19	FAN
20	GAS PRESSURE SWITCH
21	MOTOR
22	VALVE GROUP FLANGE
23	GAS PROVING SYSTEM
24	OR RING
25	AIR FLAP
26	AIR DAMPER CRANK (progressive and fully modulating only)
27	FIXING ROD
28	GAS PIPE
29.1	GAS TRANSFORMER
29.2	SMALL ADJUSTING CAM
29.3	ACTUATOR (double stage, progressive and fully modulating only)
30	PANEL ASSEMBLY
31.1	CONTROL BOX BRACKET
31.2	AIR PRESSURE SWITCH
31.3.1	CONTROL BOX
31.3.2	CONTROL BOX BOARD
31.4	CONTACTOR
32.1	BUTTERFLY MANIFOLD
32.2	HEAD EXTENSION ASSEMBLY
32.3	BUTTERFLY ASSEMBLY
32.4.1	COMBUSTION HEAD
32.4.2	DETECTION ELECTRODE
32.4.3	IGNITION ELECTRODE
32.5	IGNITION CABLE
32.6	DETECTION CABLE
33	ELECTRONIC BOARD
34	GREY/GREEN TERMINAL
35	BLACK/GREEN TERMINAL
36	BLOCKING PLATE

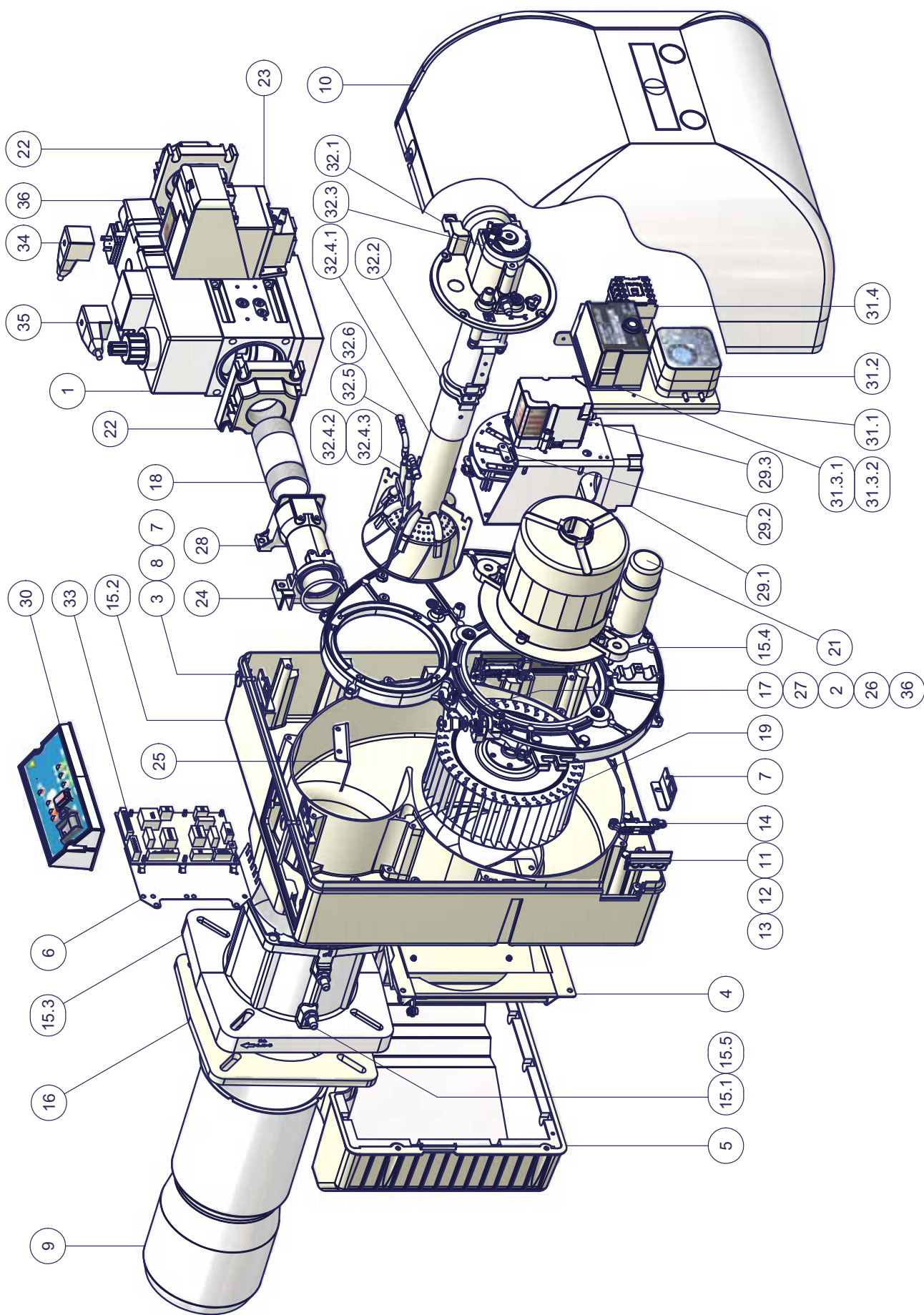



LME11 control sequence

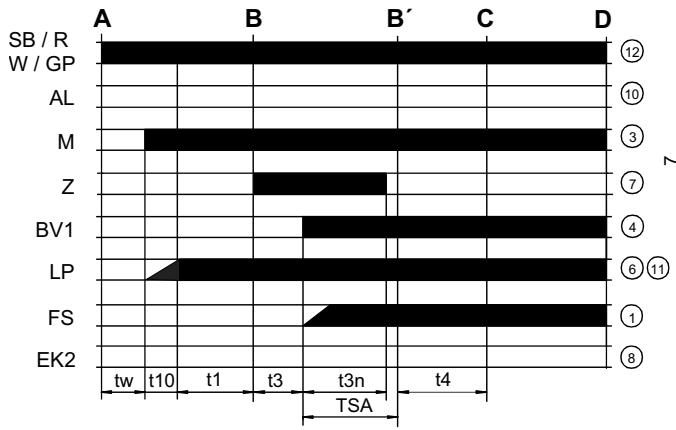

LME21 control sequence

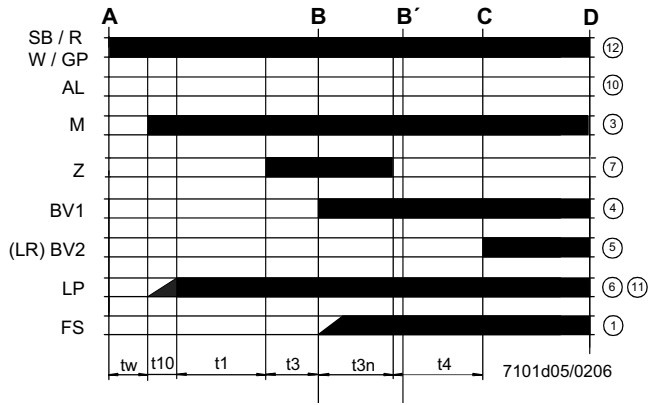

LME22 control sequence

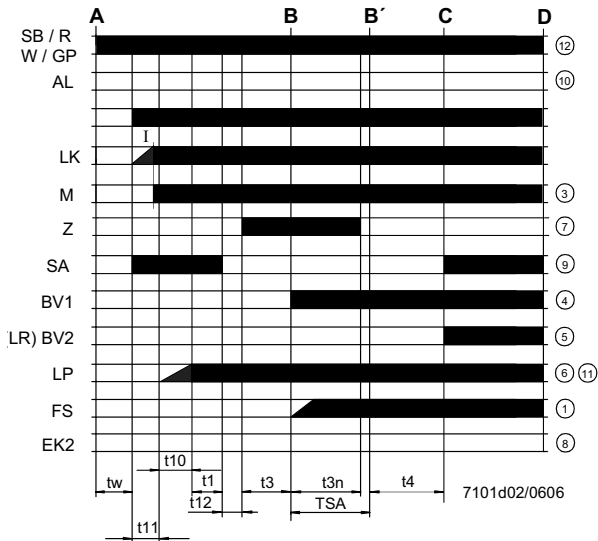

Control sequence

- $t_w$  Waiting time
- $t_1$  Purge time
- TSA Ignition safety time
- $t_3$  Preignition time
- $t_{3n}$  Postignition time
- $t_4$  Interval between BV1 and BV2/LR
- $t_{10}$  Specified time for air pressure signal
- $t_{11}$  Programmed opening time for actuator SA
- $t_{12}$  Programmed closing time for actuator SA

LME11 connection diagram

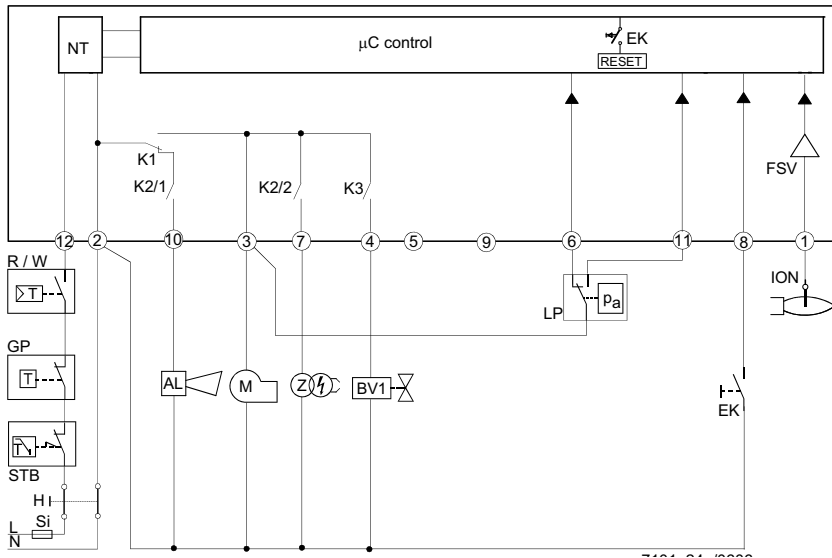

Connection diagram

- AL Error message (alarm)
- BV Fuel valve
- EK2 Remote lockout reset button
- FS Flame signal
- GP Gas pressure switch
- LP Air pressure switch
- LR Load controller
- M Fan motor
- R Control thermostat/pressurestat
- SB Safety limit thermostat
- W Limit thermostat /pressure switch
- Z Ignition transformer

LME21 connection diagram

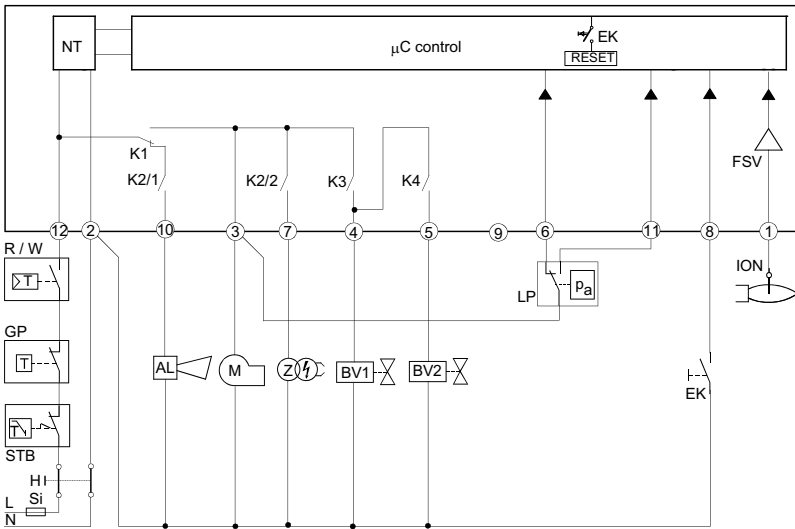

LME22 connection diagram

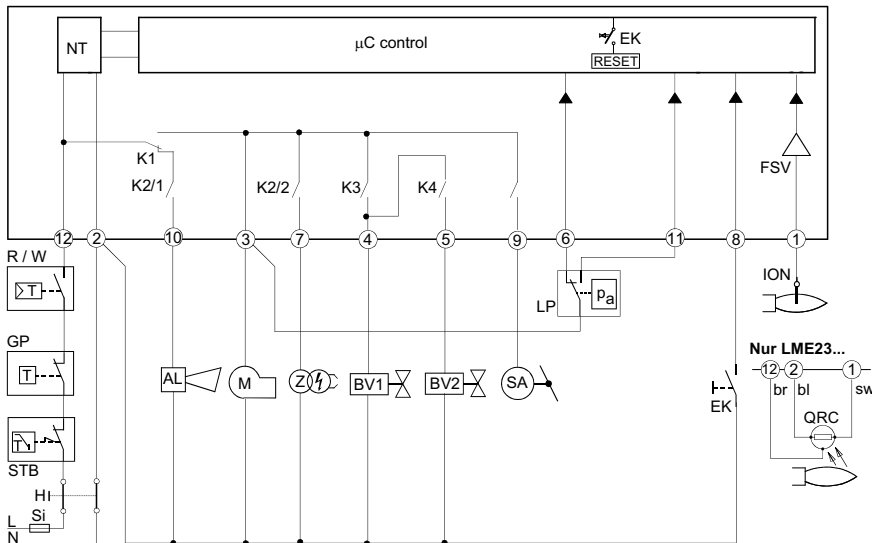

**CONTROL PROGRAM IN THE EVENT OF FAULT**

- If a fault occurs, all outputs will immediately be deactivated (in less than 1s).
- After an interruption of power, a restart will be made with the full program sequence.
- If the operating voltage drops below the undervoltage threshold, a safety shutdown is performed.
- If the operating voltage exceeds the undervoltage threshold, a restart will be performed.
- In case of extraneous light during "t1", a lockout occurs.
- In case of extraneous light during "tw", there is a prevention of startup and a lockout after 30 seconds.
- In case of no flame at the end of TSA, there will be max. 3 repetitions of the startup cycle, followed by a lockout at the end of TSA, for mod. LME11..; directly a lockout at the end of TSA for LME21-22 models.
- For LME11 model: if a loss of flame occurs during operation, in case of an establishment of flame at the end of TSA, there will be max. 3 repetitions, otherwise a lockout will occur.
- For LME21-22 models: if a loss of flame occurs during operation, there will be a lockout.
- If the contact of air pressure monitor LP is in working position, a prevention of startup and lockout after 65 seconds will occur.
- If the contact of air pressure monitor LP is in normal position, a lockout occurs at the end of t10.
- If no air pressure signal is present after completion of t1, a lockout will occur.

**CONTROL BOX LOCKED**

In the event of lockout, the LME.. remains locked and the red signal lamp (LED) will light up. The burner control can immediately be reset. This state is also maintained in the case of mains failure.

**DIAGNOSTICS OF THE CASE OF FAULT**

- Press the lockout reset button for more than 3 seconds to activate the visual diagnostics.
- Count the number of blinks of the red signal lamp and check the fault condition on the "Error code table" (the device repeats the blinks for regular intervals).

During diagnostics, the control outputs are deactivated:

- the burner remains shut down;
- external fault indication is deactivated;
- fault status is showed by the red LED, inside the LME's lockout reset button according to the "Error code table":

<b>ERROR CODE TABLE</b>	
<b>2 blinks **</b>	<p><b>No establishment of flame at the end of TSA</b></p> <ul style="list-style-type: none"> <li>- Faulty or soiled fuel valves</li> <li>- Faulty or soiled flame detector</li> <li>- Inadequate adjustment of burner, no fuel</li> <li>- Faulty ignition equipment</li> </ul>
<b>3 blinks ***</b>	<p><b>The air pressure switch does not switch or remains in idle position:</b></p> <ul style="list-style-type: none"> <li>- LP is faulty</li> <li>- Loss of air pressure signal after t10</li> <li>- LP is welded in normal position.</li> </ul>
<b>4 blinks ****</b>	- Extraneous light when burner starts up.
<b>5 blinks *****</b>	- LP is working position.
<b>6 blinks *****</b>	Free.
<b>7 blinks *****</b>	<p><b>Loss of flame during operation</b></p> <ul style="list-style-type: none"> <li>- Faulty or soiled fuel valves</li> <li>- Faulty or soiled flame detector</li> <li>- Inadequate adjustment of burner</li> </ul>
<b>8 ÷ 9 blinks</b>	Free
<b>10 blinks *****</b>	<p><b>Faulty output contacts</b></p> <p><b>Attention: "lockout" remote signal (terminal no. 10) not enabled</b></p> <ul style="list-style-type: none"> <li>- Wiring error</li> <li>- Anomalous voltage on output terminals</li> <li>- Other faults</li> </ul>
<b>14 blinks ***** (only for LME4x)</b>	- CPI contact (gas valve microswitch) not closed.

**RESETTING THE BURNER CONTROL**

When lockout occurs, the burner control can immediately be reset, by pressing the lockout reset button for about 1.3 seconds. The LME.. can only be reset when all contacts in the line are closed and when there is no undervoltage.

**LIMITATION OF REPETITIONS (only for LME11.. model)**

If no flame is established at the end of TSA, or if the flame is lost during operation, a maximum of 3 repetitions per controller startup can be performed via "R", otherwise lockout will be initiated. Counting of repetitions is restarted each time a controlled startup via "R" takes place.

**⚠ Condensation, formation of ice and ingress of water are not permitted!**

**TECHNICAL CHARACTERISTICS**

Mains voltage	120V AC +10% / -15%
	230V AC +10% / -15%
Frequency	50 ... 60 Hz +/- 6%
Power consumption	12VA
External primary fuse	max. 10 A (slow)
input current at terminal 12	max. 5 A
Detection cable length	max. 3m (for electrode)
Detection cable length	max. 20 m (laid separately, for QRA probe)
Reset cable length	max. 20 m (posato separatamente)
Term. 8 & 10 cable length	max. 20 m
Thermostat cable length and other terminals	max. 3 m
Safety class	I
Index of protection	IP40 (to be ensured during mounting)
Operating conditions	-20... +60 °C, < 95% UR
Storage conditions	-20... +60 °C, < 95% UR
Weight	approx. 160 g









C.I.B. UNIGAS S.p.A.  
Via L.Galvani, 9 - 35011 Campodarsego (PD) - ITALY  
Tel. +39 049 9200944 - Fax +39 049 9200945/9201269  
web site: [www.cibunigas.it](http://www.cibunigas.it) - e-mail: [cibunigas@cibunigas.it](mailto:cibunigas@cibunigas.it)

Note: specifications and data subject to change. Errors and omissions exceptd.



***CIB UNIGAS***

***LG/NG/NGX280***

***LG/NG/NGX350***

***LG/NG/NGX400***

***WIRING DIAGRAMS***

---

## ELECTRICAL WIRING DIAGRAMS

### Electric wiring diagrams

#### Wiring diagram 18-163 - Complete key

C1	LOW FLAME TIME METER
C2	HIGH FLAME TIME METER
ER	FLAME DETECTION ELECTRODE
EV1,2	GAS ELECTRO-VALVES (OR VALVES GROUP)
FU1	FAN MOTOR LINE FUSE
FU2	LINE FUSE
FU3	LINE FUSE
FU4	AUXILIARY FUSE
IL	BURNER LINE SWITCH
IM	FAN MOTOR LINE SWITCH
KM1	FAN MOTOR CONTACTOR
LAF	BURNER IN HIGH FLAME INDICATOR LIGHT
LB	INDICATOR LIGHT FOR BURNER LOCK-OUT
LBF	BURNER IN LOW FLAME INDICATOR LIGHT
LEV1	INDICATOR LIGHT FOR OPENING OF ELECTRO-VALVE EV2
LEV2	INDICATOR LIGHT FOR OPENING OF ELECTRO-VALVE EV2
LF	INDICATOR LIGHT BURNER FUNCTIONING
LGB2x.330/LMG2x330	CONTROL BOX
LPG	INDICATOR LIGHT FOR PRESENCE OF GAS IN THE NETWORK
LTA	IGNITION TRANSFORMER INDICATOR LIGHT
MV	FAN MOTOR
PA	COMBUSTION AIR PRESSURE SWITCH
PG	MINIMUM GAS PRESSURE SWITCH
PS	LOCK-OUT RESET BUTTON
PT100	TEMPERATURE PROBE
RC	RC CIRCUIT
SATRONIC DLG976	CONTROL BOX
SATRONIC DMG972	CONTROL BOX
SD-0÷10V	VOLTAGE SIGNAL
SD-0/4÷20mA	CURRENT SIGNAL
SD-PRESS	PRESSURE PROBE
SD-TEMP	TEMPERATURE PROBE
SIEMENS LME..	CONTROL BOX
SIEMENS RWF40	MODULATORSMANUAL/AUTOMATIC SELECTOR
SMF	MIN-0-MAX FUNCTIONING MANUAL SELECTOR
ST	SERIES OF THERMOSTATS OR PRESSURE SWITCHES
STA/SQN72	AIR DAMPER ACTUATOR
TA	IGNITION TRANSFORMER
TAB	HIGH-LOW THERMOSTAT/PRESSURE SWITCHES
TC	THERMOCOUPLE
TS	SAFETY THERMOSTAT OR PRESSURE SWITCH
VPS504	GAS PROVING SYSTEM (OPTIONAL)
(#)	FAN MOTOR 620 W D 450W, FU2= 6,3 A F; FAN MOTOR 370 W , FU2= 10 A F
(*)	BRIDGE BETWEEN TERMINALS7 AND 9 ONLY WITH LGB21.330 (SINGLE STAGE VERSION ONLY)
(**)	SEE PROBE CONNECTION
(***)	WITH ELECTRIC SUPPLY WITHOUT NEUTRAL VERSION ONLY
(\$)	IF "TAB" USED REMOVE THE BRIDGE BETWEEN TERMINALS T6-T8

#### WARNING:

- 1 - Electrical supply 230V 50/60Hz 1N a.c.
- 2 - Do not reverse phase with neutral
- 3 - Ensure burner is properly earthed

#### LG/NG/NGX 280 Single stage - Electric wiring diagrams - SE01-530

#### LG/NG/NGX 280 Double stage - Progressive - Electric wiring diagrams - SE18-103

#### LG/NG/NGX 350-400 Electric wiring diagrams - SE18-163

#### LG/NG/NGX 350-400 Electric wiring diagrams - SE18-057

#### SE00\_TAB1-1

##### KEYS

<b>C1</b>	LOW FLAME TIME COUNTER	<b>LAF</b>	BURNER IN HIGH FLAME INDICATOR LIGHT
<b>C2</b>	HIGH FLAME TIME COUNTER	<b>LB</b>	INDICATOR LIGHT FOR BURNER LOCK-OUT
<b>FU1</b>	FAN MOTOR LINE FUSE	<b>LBF</b>	BURNER IN LOW FLAME INDICATOR LIGHT
<b>FU3</b>	BURNER LINE FUSE	<b>ST</b>	SERIES OF THERMOSTATS OR PRESSURE SWITCHES
<b>IL</b>	BURNER LINE SWITCH	<b>TAB</b>	HIGH-LOW THERMOSTAT/PRESSURE SWITCHES
<b>IM</b>	FAN MOTOR LINE SWITCH	<b>TS</b>	SAFETY THERMOSTAT OR PRESSURE SWITCH
<b>KAB</b>	AUXILIARY RELAY		

SIEMENS LGB21.33/LGB22.33/LMG21.33/LMG22.33/LME21.33/LME22.33

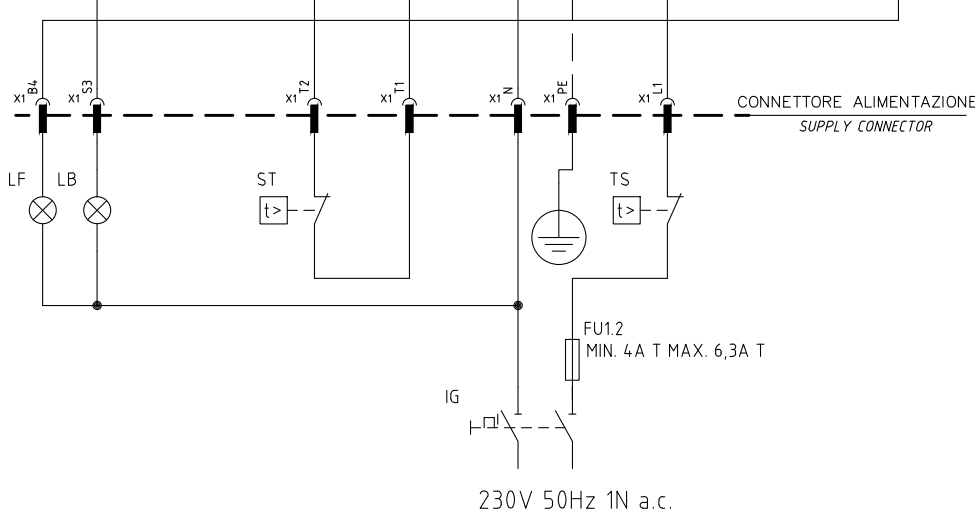
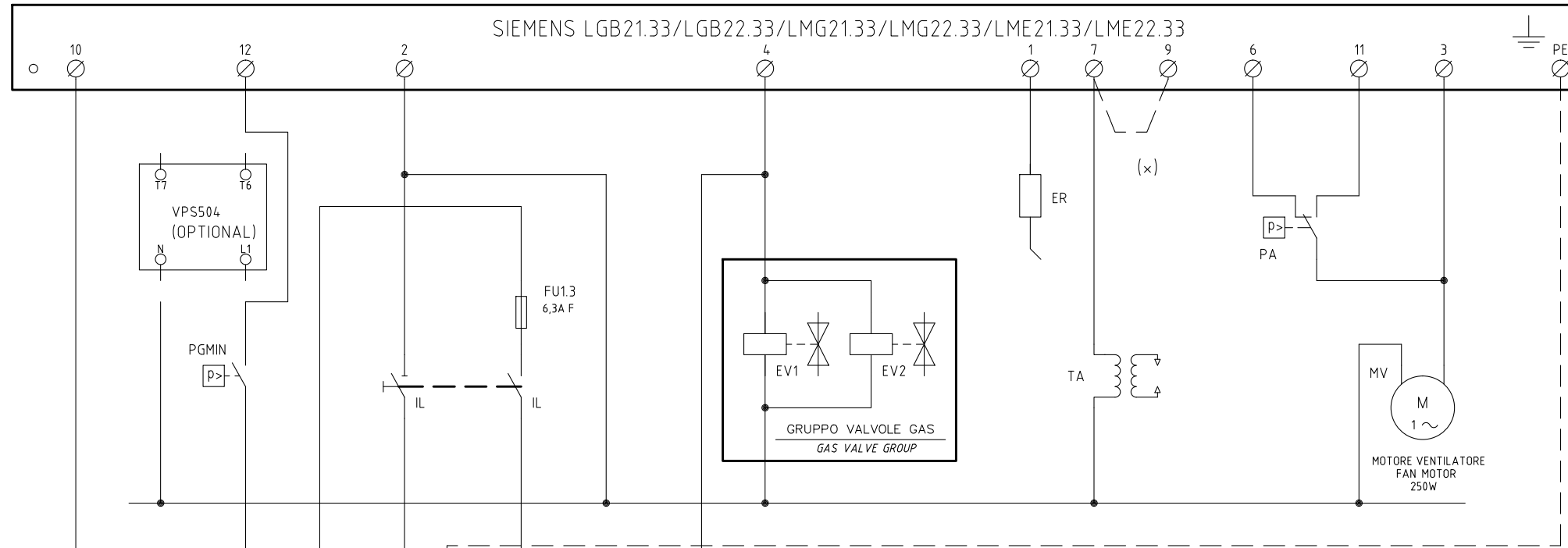

(x)  
FARE PONTE TRA I MORSETTI 7 E 9 SOLO CON LGB21.330  
CONNECTION BETWEEN TERMINALS 7 AND 9 WITH LGB21.330 ONLY

Data	21/07/2006	PREC.	FOGLIO
Revisione	00	/	1
Dis. N.	01 - 530	SEGUE	TOTALE
		2	2

SIGLA/ITEM	FOGLIO/SHEET	FUNZIONE	FUNCTION
ER	1	ELETTRODO RIVELAZIONE FIAMMA	FLAME DETECTION ELECTRODE
EV1	1	ELETTROVALVOLA GAS LATO RETE (O GRUPPO VALVOLE)	GAS ELECTRO-VALVE UPSTREAM (OR VALVES GROUP)
EV2	1	ELETTROVALVOLA GAS LATO BRUCIATORE (O GRUPPO VALVOLE)	GAS ELECTRO-VALVE DOWNSTREAM (OR VALVES GROUP)
FU1.2	1	FUSIBILE DI LINEA	LINE FUSE
FU1.3	1	FUSIBILE AUSILIARIO	AUXILIARY FUSE
IG	1	INTERRUTTORE GENERALE	MAIN DISCONNECTOR
IL	1	INTERRUTTORE LINEA BRUCIATORE	BURNER LINE SWITCH
LB	1	LAMPADA SEGNALAZIONE BLOCCO BRUCIATORE	INDICATOR LIGHT FOR BURNER LOCK-OUT
LF	1	LAMPADA SEGNALAZIONE FUNZIONAMENTO BRUCIATORE	INDICATOR LIGHT BURNER OPERATION
MV	1	MOTORE VENTILATORE	FAN MOTOR
PA	1	PRESSOSTATO ARIA COMBURENTE	COMBUSTION AIR PRESSURE SWITCH
PGMIN	1	PRESSOSTATO GAS DI MINIMA PRESSIONE	MINIMUM GAS PRESSURE SWITCH
SIEMENS LGB../LMG../LME..	1	APPARECCHIATURA CONTROLLO FIAMMA	FLAME MONITOR DEVICE
ST	1	SERIE TERMOSTATI/PRESSOSTATI	SERIES OF THERMOSTATS OR PRESSURE SWITCHES
TA	1	TRASFORMATORE DI ACCENSIONE	IGNITION TRANSFORMER
TS	1	TERMOSTATO/PRESSOSTATO DI SICUREZZA	SAFETY THERMOSTAT OR PRESSURE SWITCH
VPS504	1	CONTROLLO DI TENUTA VALVOLE GAS (OPTIONAL)	GAS LEAKAGE MONITOR DEVICE (OPTIONAL)

Data	21/07/2006	PREC.	FOGLIO
Revisione	00	1	2
Dis. N.	01 - 530	SEGUE	TOTALE
		/	2

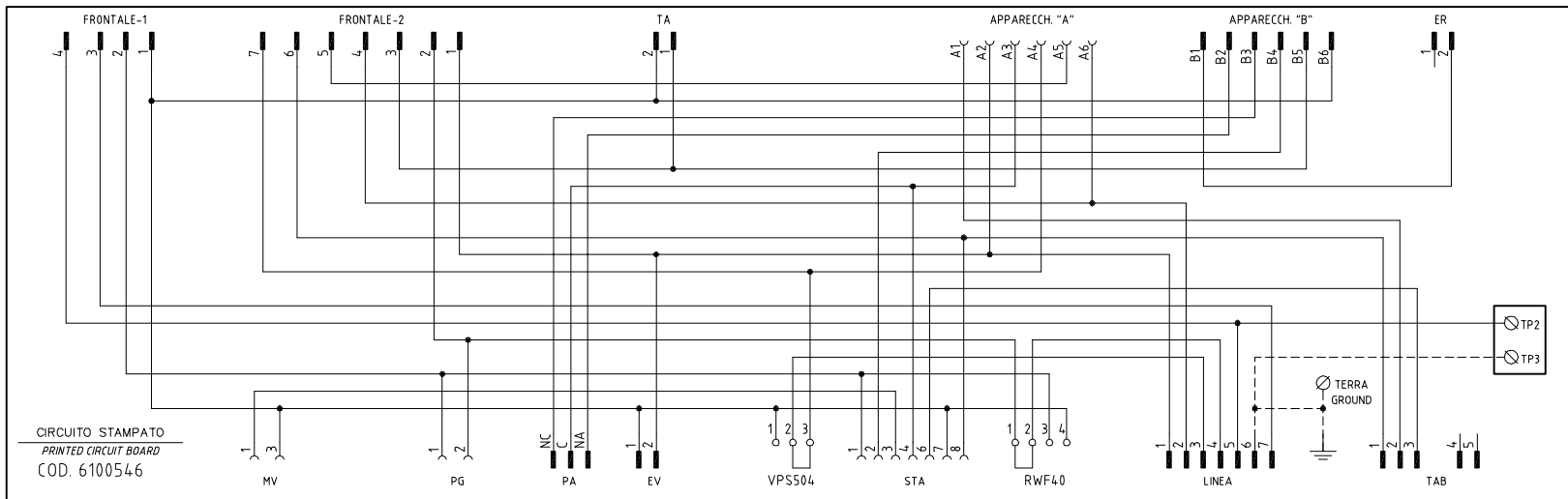
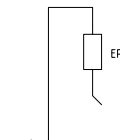
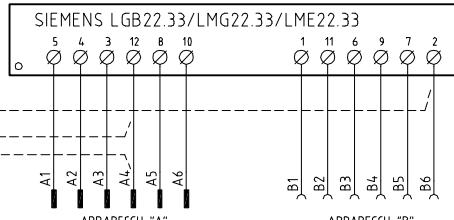
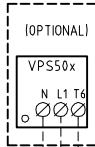
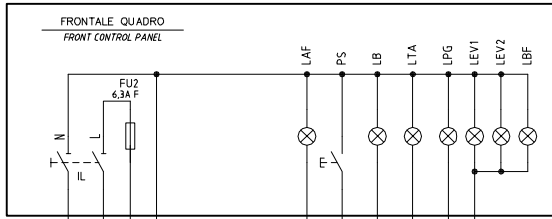

CIRCUITO STAMPATO  
PRINTED CIRCUIT BOARD  
COD. 6100546

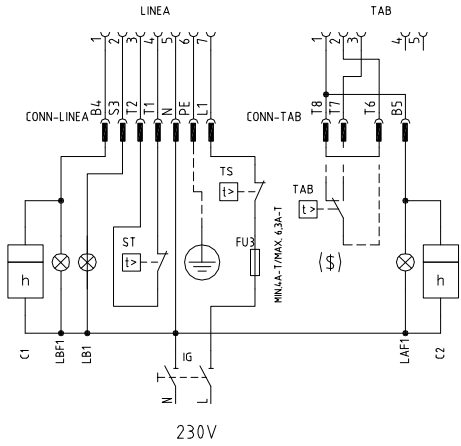
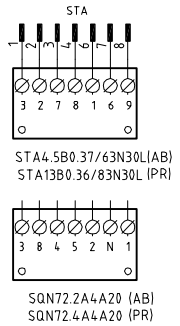
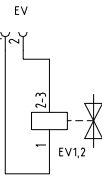
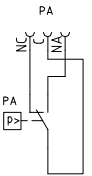
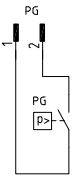
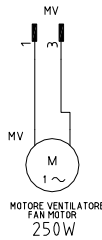

CAMME SERVOCOMANDO SERRANDA ARIA VERSIONE (AB)  
CAMS OF AIR DAMPER ACTUATOR VERSION (AB)  
STA4.5B0.37/63N30L / STA13B0.36/83N30L

I ALTA FIAMMA HIGH FLAME  
II SOSTA STAND-BY  
IV BASSA FIAMMA LOW FLAME  
III (ARANCIO) NON USATA NOT USED

CAMME SERVOCOMANDO SERRANDA ARIA VERSIONE (PR)  
CAMS OF AIR DAMPER ACTUATOR VERSION (PR)  
SQN72.xA4A20

I (ROSSO) ALTA FIAMMA HIGH FLAME  
II (VERDE) SOSTA STAND-BY  
III (BLAU) SOSTA STAND-BY  
III (ARANCIO) BASSA FIAMMA LOW FLAME  
IV (NERO) NON USATA NOT USED

(xxx) SOLO CON ALIMENTAZIONE ELETTRICA SENZA NEUTRO  
WITH ELECTRIC SUPPLY WITHOUT NEUTRAL VERSION ONLY

(\$) SE USATO "TAB", TOGLIERE IL PONTE TRA I MORSETTI T6-T8  
IF USED "TAB", REMOVE THE BRIDGE BETWEEN TERMINALS T6-T8

Data	21/07/2006	PREC.	FOGLIO
Revisione	01	/	1
Dis. N.	18 - 103	SEQUE	TOTALE
		2	2

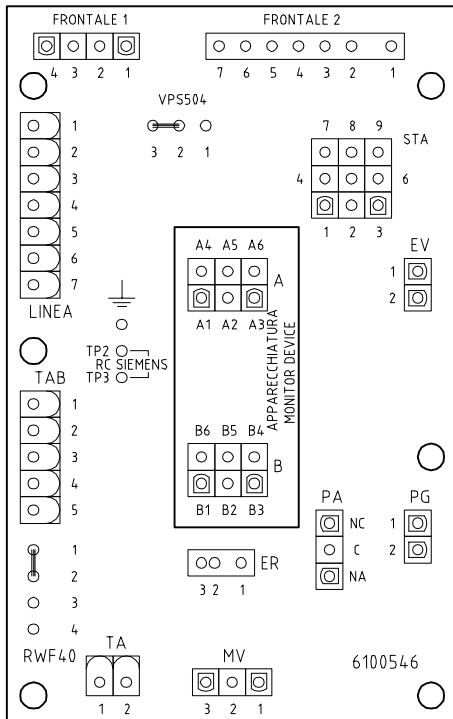

SIGLA/ITEM	FUNZIONE	FUNCTION
C1	CONTAORE BASSA FIAMMA	LOW FLAME TIME COUNTER
C2	CONTAORE ALTA FIAMMA	HIGH FLAME TIME COUNTER
ER	ELETTRODO RILEVAZIONE FIAMMA	FLAME DETECTION ELECTRODE
EV1,2	ELETTROVALVOLE GAS (O GRUPPO VALVOLE)	GAS ELECTRO-VALVES (OR VALVES GROUP)
FU2	FUSIBILE DI LINEA	LINE FUSE
FU3	FUSIBILE LINEA BRUCIATORE	BURNER LINE FUSE
IG	INTERRUTTORE LINEA BRUCIATORE	BURNER LINE SWITCH
IL	INTERRUTTORE LINEA AUSILIARI	AUXILIARY LINE SWITCH
LAF	LAMPADA SEGNAZIONE ALTA FIAMMA BRUCIATORE	BURNER IN HIGH FLAME INDICATOR LIGHT
LAF1	LAMPADA SEGNAZIONE ALTA FIAMMA BRUCIATORE	BURNER IN HIGH FLAME INDICATOR LIGHT
LB	LAMPADA SEGNAZIONE BLOCCO BRUCIATORE	INDICATOR LIGHT FOR BURNER LOCK-OUT
LB1	LAMPADA SEGNAZIONE BLOCCO BRUCIATORE	INDICATOR LIGHT FOR BURNER LOCK-OUT
LBF	LAMPADA SEGNAZIONE BASSA FIAMMA BRUCIATORE	BURNER IN LOW FLAME INDICATOR LIGHT
LBF1	LAMPADA SEGNAZIONE BASSA FIAMMA BRUCIATORE	BURNER IN LOW FLAME INDICATOR LIGHT
LEV1	LAMPADA SEGNAZIONE APERTURA [EV1]	INDICATOR LIGHT FOR OPENING OF ELECTRO-VALVE [EV1]
LEV2	LAMPADA SEGNAZIONE APERTURA [EV2]	INDICATOR LIGHT FOR OPENING OF ELECTRO-VALVE [EV2]
LPG	LAMPADA SEGNAZIONE PRESENZA GAS IN RETE	INDICATOR LIGHT FOR PRESENCE OF GAS IN THE NETWORK
LTA	LAMPADA SEGNAZIONE TRASFORMATORE DI ACCENSIONE	IGNITION TRANSFORMER INDICATOR LIGHT
MV	MOTORE VENTILATORE	FAN MOTOR
PA	PRESSOSTATO ARIA	AIR PRESSURE SWITCH
PG	PRESSOSTATO GAS DI MINIMA PRESSIONE	MINIMUM GAS PRESSURE SWITCH
PS	PULSANTE SBLOCCO FIAMMA	LOCK-OUT RESET BUTTON
RC	CIRCUITO RC	RC CIRCUIT
SIEMENS LGB22.33/LMG22.33/LME22.33	APPARECCHIATURA CONTROLLO FIAMMA	CONTROL BOX
SQN72.2A4A20	SERVOCOMANDO SERRANDA ARIA VERSIONE [AB]	AIR DAMPER ACTUATOR VERSION [AB]
SQN72.4A4A20	SERVOCOMANDO SERRANDA ARIA VERSIONE [PR]	AIR DAMPER ACTUATOR VERSION [PR]
ST	SERIE TERMOSTATI/PRESSOSTATI	SERIES OF THERMOSTATS OR PRESSURE SWITCHES
STA4.5B0.37/63N30L	SERVOCOMANDO SERRANDA ARIA VERSIONE [AB]	AIR DAMPER ACTUATOR VERSION [AB]
STA13B0.36/83N30L	SERVOCOMANDO SERRANDA ARIA VERSIONE [PR]	AIR DAMPER ACTUATOR VERSION [PR]
TA	TRASFORMATORE DI ACCENSIONE	IGNITION TRANSFORMER
TAB	TERMOSTATO/PRESSOSTATO ALTA-BASSA FIAMMA	HIGH-LOW THERMOSTAT/PRESSURE SWITCHES
TS	TERMOSTATO/PRESSOSTATO DI SICUREZZA	SAFETY THERMOSTAT OR PRESSURE SWITCH
VPS50x	CONTROLLO DI TENUTA VALVOLE GAS (OPTIONAL)	GAS PROVING SYSTEM (OPTIONAL)

Data	21/07/2006	PREC.	FOGLIO
Revisione	01	1	2
Dis. N.	18 - 103	SEQUE	TOTALE
		/	2

# VERSIONE MONOSTADIO "TN" "TN" SINGLE-STAGE VERSION

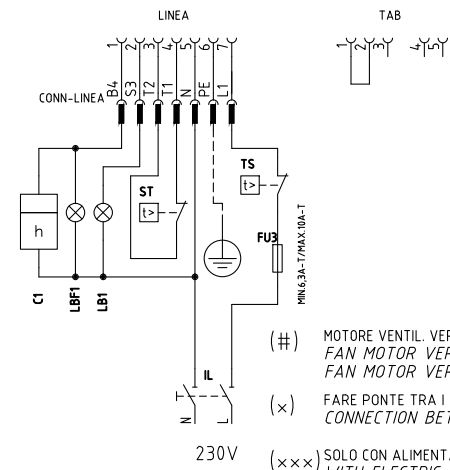
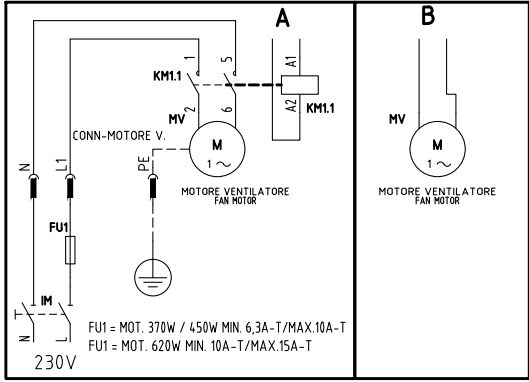
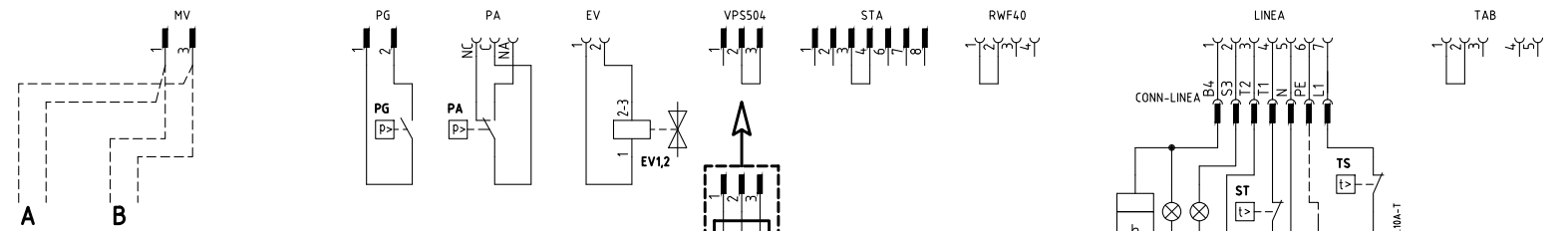
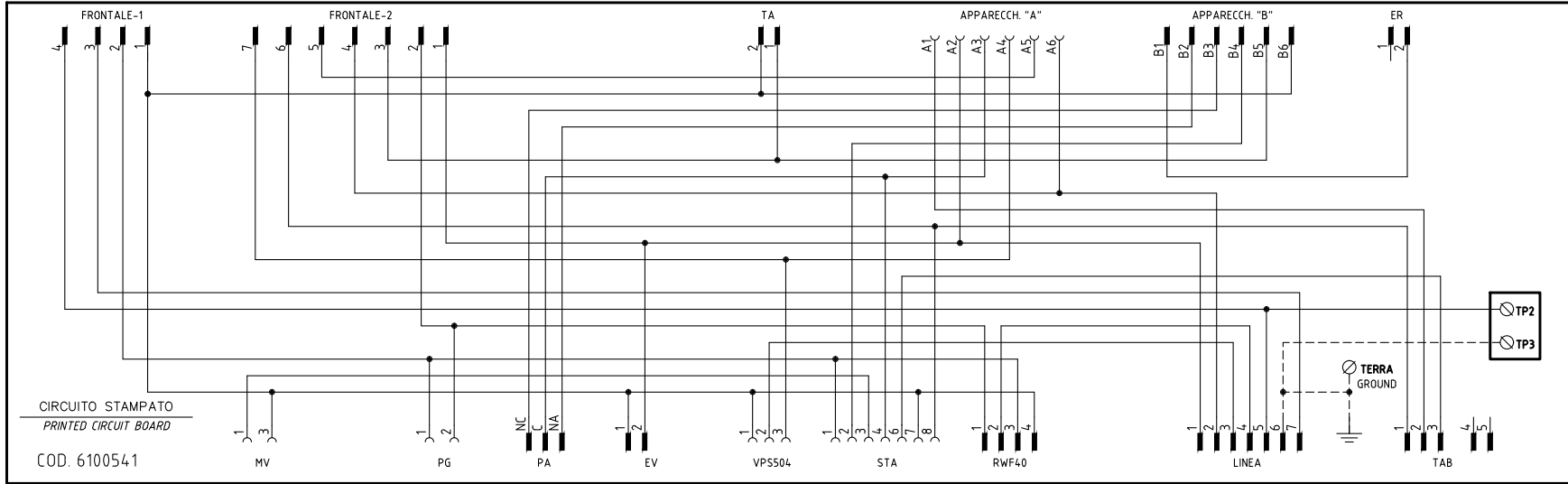
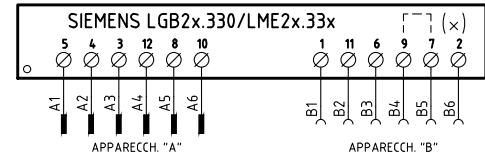
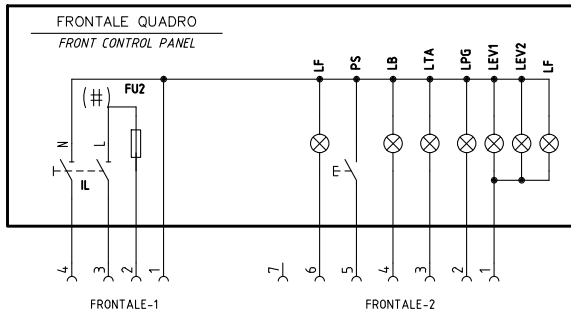

- (#) MOTORE VENTIL. VERSIONE [A], FU2 = 6,3A F; MOTORE VENTIL. VERSIONE [B], FU2 = 10A F  
FAN MOTOR VERSION [A], FU2 = 6,3 A F;  
FAN MOTOR VERSION [B], FU2 = 10 A F
- (x) FARE PONTE TRA I MORSETTI 7 E 9 SOLO CON LGB21.330  
CONNECTION BETWEEN TERMINALS 7 AND 9 WITH LGB21.330 ONLY
- (x x x) SOLO CON ALIMENTAZIONE ELETTRICA SENZA NEUTRO  
WITH ELECTRIC SUPPLY WITHOUT NEUTRAL VERSION ONLY

Data	19/10/2010	PREC.	FOGLIO
Revisione	05	/	1
Dis. N.	18 - 0163	SEGUE	TOTALE
		2	5

VERSIONE ALTA-BASSA FIAMMA "AB" / PROGRESSIVO "PR"  
 "AB" HIGH-LOW / "PR" PROGRESSIVE VERSION

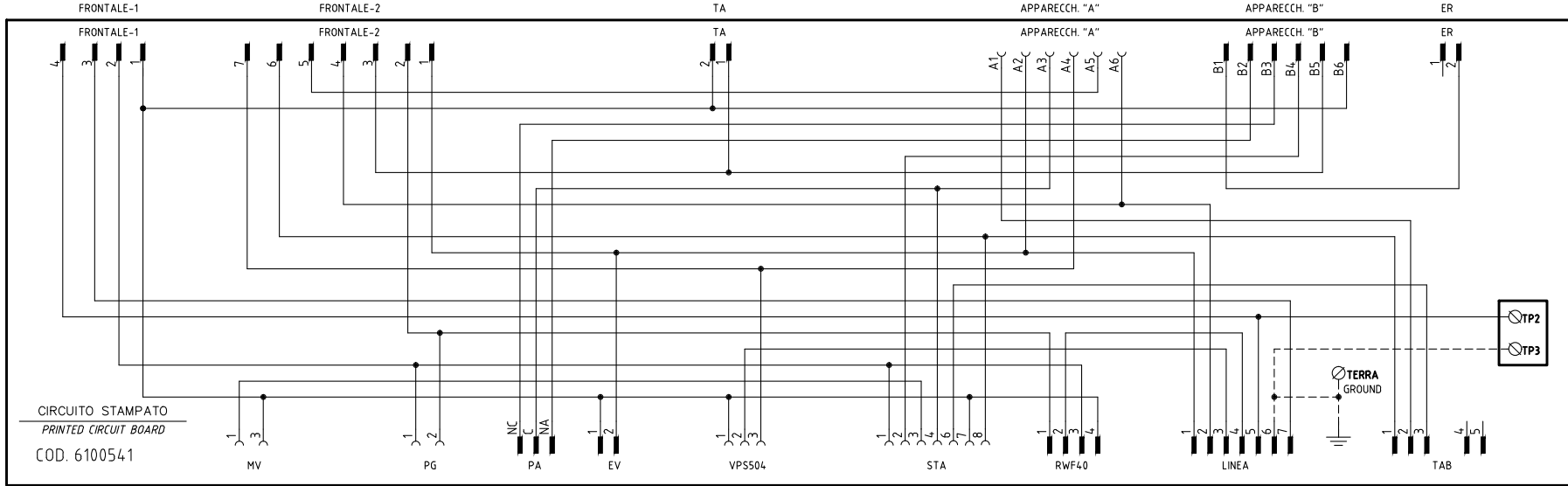
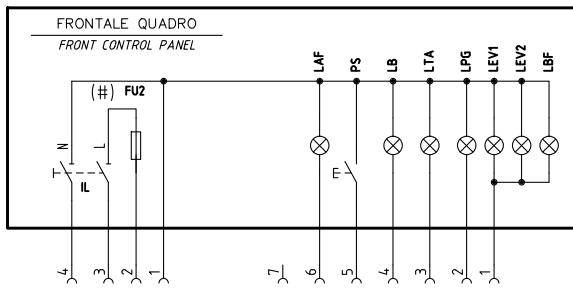

SERVOCOMANDO SERRANDA ARIA  
 AIR DAMPER ACTUATOR  
 STA13B0.36/83N30L

I ALTA FIAMMA  
 HIGH FLAME  
 SOSTA  
 STAND-BY  
 II BASSA FIAMMA  
 LOW FLAME  
 III NON USATA  
 NOT USED

SERVOCOMANDO SERRANDA ARIA  
 AIR DAMPER ACTUATOR  
 SIEMENS SQNT2.xA4.A20

I (ROSSO) ALTA FIAMMA  
 HIGH FLAME  
 II (BLU) SOSTA  
 STAND-BY  
 III (ARANCIO) BASSA FIAMMA  
 LOW FLAME  
 IV (NERO) NON USATA  
 NOT USED

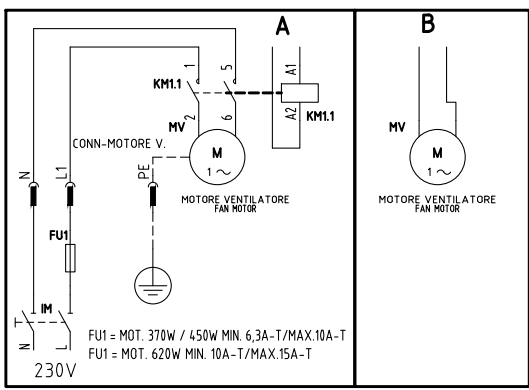
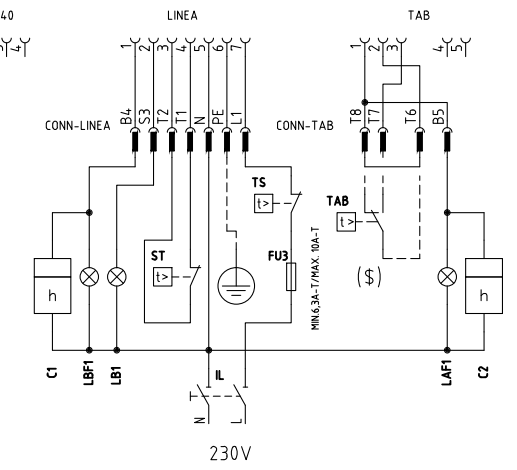
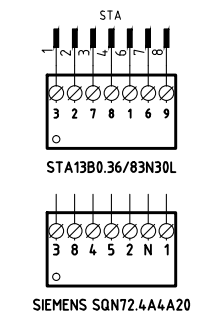
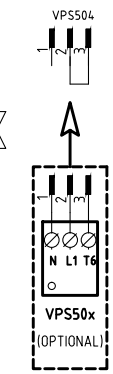
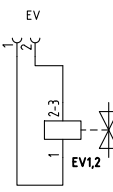
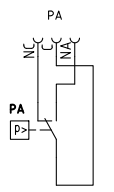
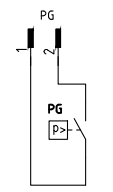
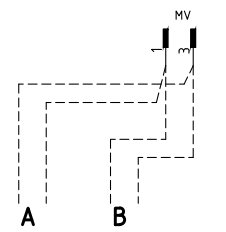

(#) MOTORE VENTIL. VERSIONE [A], FU2 = 6,3A F; MOTORE VENTIL. VERSIONE [B], FU2 = 10A F  
 FAN MOTOR VERSION [A], FU2 = 6,3 A F;  
 FAN MOTOR VERSION [B], FU2 = 10 A F

(x x x) SOLO CON ALIMENTAZIONE ELETTRICA SENZA NEUTRO  
 WITH ELECTRIC SUPPLY WITHOUT NEUTRAL VERSION ONLY

(\$) SE USATO "TAB", TOGLIERE IL PONTE TRA I MORSETTI T6-T8  
 IF USED "TAB", REMOVE THE BRIDGE BETWEEN TERMINALS T6-T8

Data	19/10/2010	PREC.	FOGLIO
Revisione	05	1	2
Dis. N.	18 - 0163	SEGUE	TOTALE
		3	5

VERSIONE MODULANTE "MD"  
"MD" MODULATING VERSION

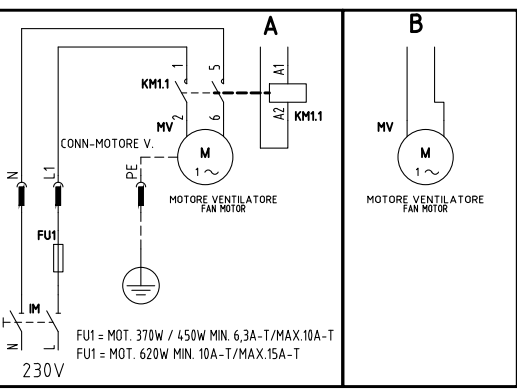
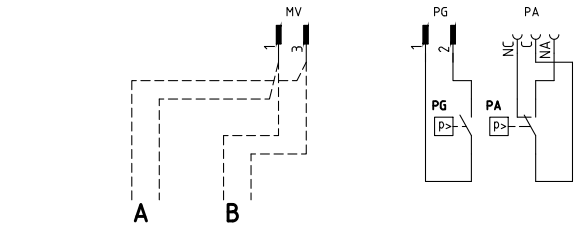
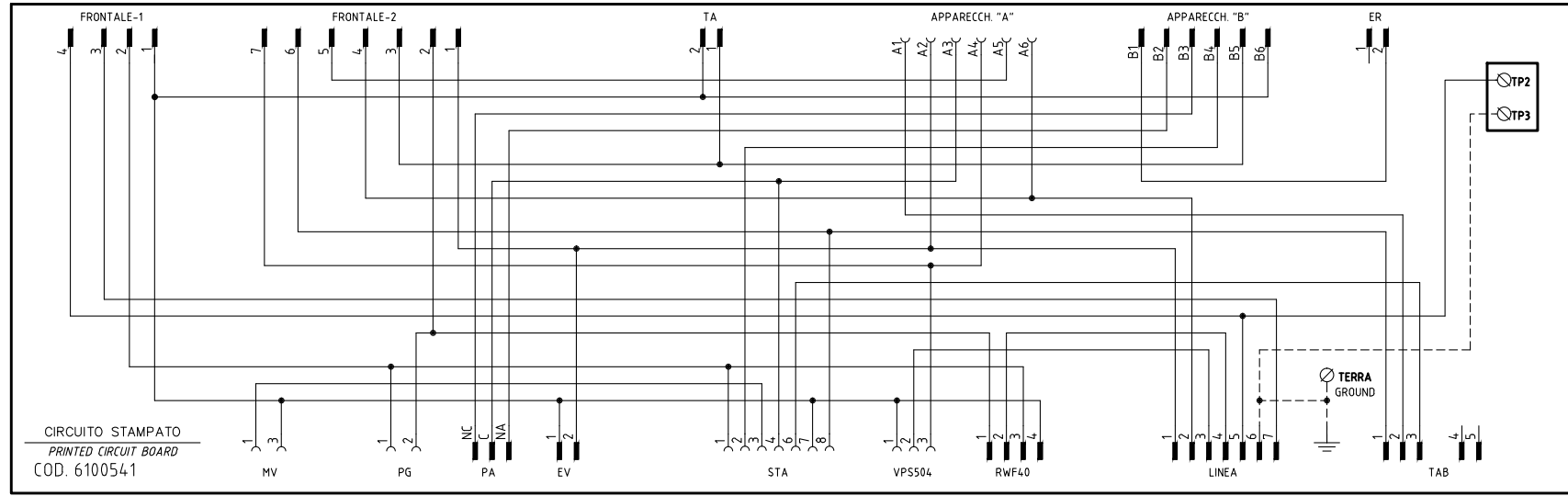
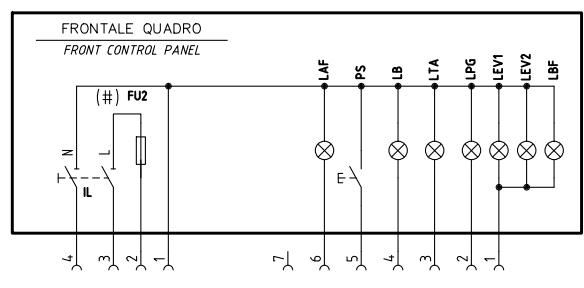

SERVOCOMANDO SERRANDA ARIA  
AIR DAMPER ACTUATOR  
STA13B0.36/83N30L

I ALTA FIAMMA HIGH FLAME  
II SOSTA STAND-BY  
III BASSA FIAMMA LOW FLAME  
IV NON USATA NOT USED

SERVOCOMANDO SERRANDA ARIA  
AIR DAMPER ACTUATOR  
SIEMENS SQN72.xA4.A20

I (ROSSO) ALTA FIAMMA HIGH FLAME  
II (BLU) SOSTA STAND-BY  
III (ARANCIO) BASSA FIAMMA LOW FLAME  
IV (NERO) NON USATA NOT USED

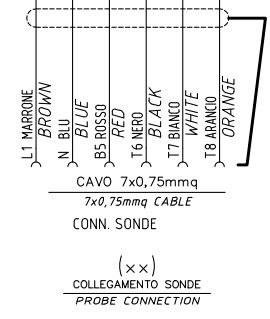
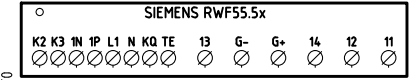
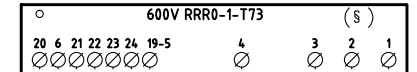
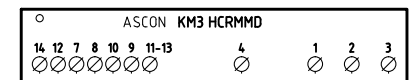
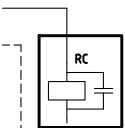
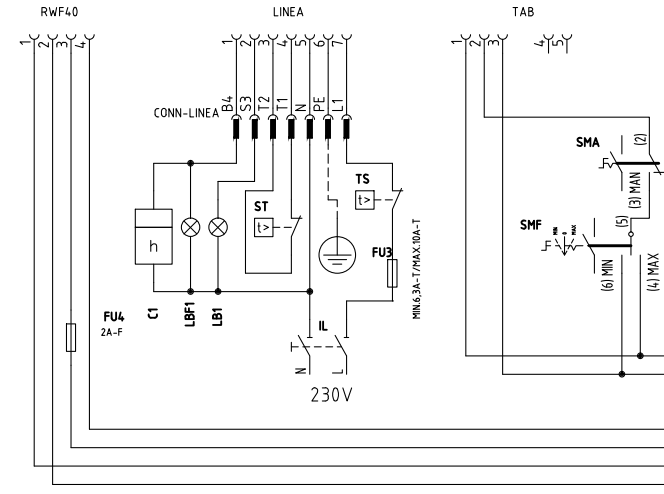
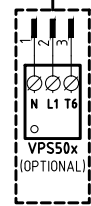
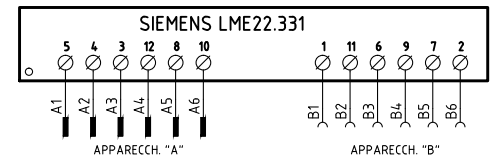

(#) MOTORE VENTIL. VERSIONE [A], FU2 = 6,3A F; MOTORE VENTIL. VERSIONE [B], FU2 = 10A F  
FAN MOTOR VERSION [A], FU2= 6,3 A F;  
FAN MOTOR VERSION [B], FU2= 10 A F

(x x x) SOLO CON ALIMENTAZIONE ELETTRICA SENZA NEUTRO  
WITH ELECTRIC SUPPLY WITHOUT NEUTRAL VERSION ONLY

Data	19/10/2010	PREC.	FOGLIO
Revisione	05	2	3
Dis. N.	18 - 0163	SEQUE	TOTALE
		4	5

(xx)  
 ATTENZIONE COLLEGAMENTO SONDE CON CONNETTORE 7 POLI  
 WARNING PROBE CONNECTION WITH 7 PINS CONNECTOR

### KM3 HCRMMD

### 600V RRR0-1-T73

### RWF55.5x

### RWF50.2x

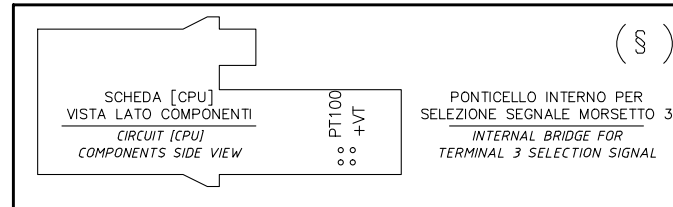
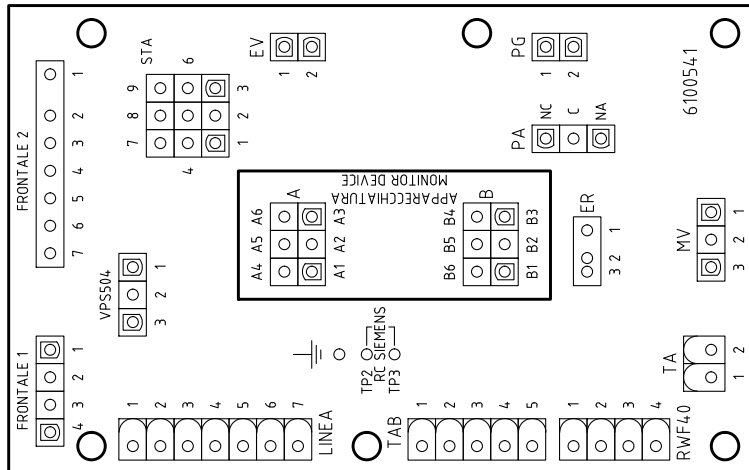
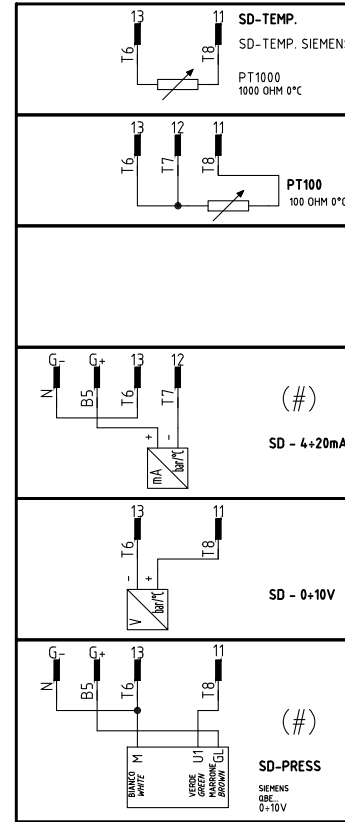
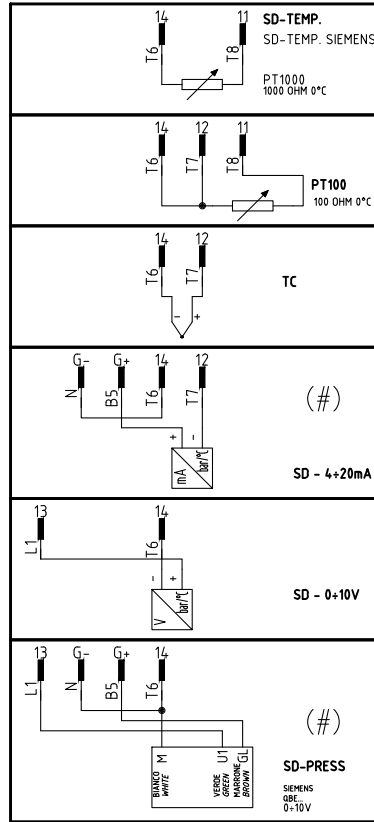
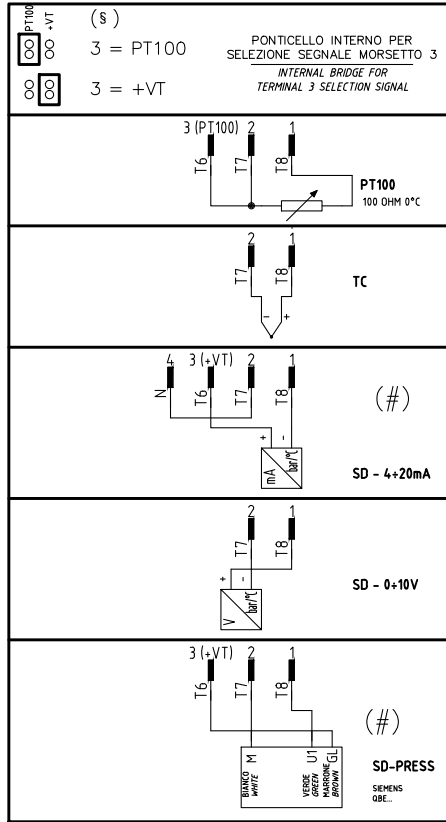
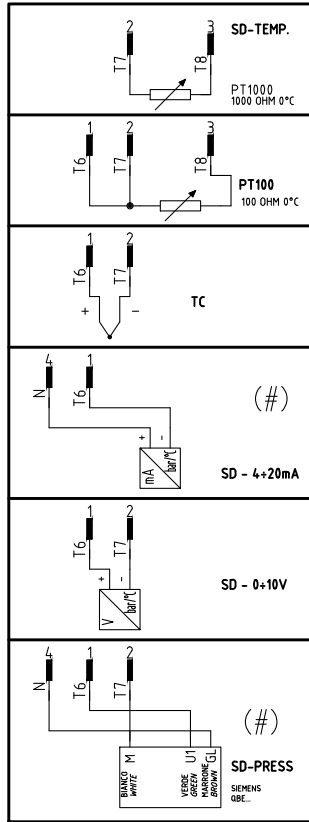

Data	19/10/2010	PREC.	FOGLIO
Revisione	05	3	4
Dis. N.	18 - 0163	SEGUE	TOTALE
		5	5

Sigla/Item	Funzione	Function
600V RRR0-1-T73	REGOLATORE MODULANTE (ALTERNATIVO)	BURNER MODULATOR (ALTERNATIVE)
C1	CONTAORE BASSA FIAMMA	LOW FLAME TIME COUNTER
C2	CONTAORE ALTA FIAMMA	HIGH FLAME TIME COUNTER
ER	ELETTRODO RILEVAZIONE FIAMMA	FLAME DETECTION ELECTRODE
EV1,2	ELETTROVALVOLE GAS (O GRUPPO VALVOLE)	GAS ELECTRO-VALVES (OR VALVES GROUP)
FU1	FUSIBILE LINEA MOTORE VENTILATORE	FAN MOTOR LINE FUSE
FU2	FUSIBILE DI LINEA	LINE FUSE
FU3	FUSIBILE DI LINEA	LINE FUSE
FU4	FUSIBILE AUSILIARIO	AUXILIARY FUSE
IL	INTERRUTTORE LINEA BRUCIATORE	BURNER LINE SWITCH
IM	INTERRUTTORE LINEA MOTORE VENTILATORE	FAN MOTOR LINE SWITCH
KM1.1	CONTATTORE MOTORE VENTILATORE	FAN MOTOR CONTACTOR
KM3 HCRMMD	REGOLATORE MODULANTE (ALTERNATIVO)	BURNER MODULATOR (ALTERNATIVE)
LAF	LAMPADA SEGNALAZIONE ALTA FIAMMA BRUCIATORE	BURNER IN HIGH FLAME INDICATOR LIGHT
LAF1	LAMPADA SEGNALAZIONE ALTA FIAMMA BRUCIATORE	BURNER IN HIGH FLAME INDICATOR LIGHT
LB	LAMPADA SEGNALAZIONE BLOCCO BRUCIATORE	INDICATOR LIGHT FOR BURNER LOCK-OUT
LB1	LAMPADA SEGNALAZIONE BLOCCO BRUCIATORE	INDICATOR LIGHT FOR BURNER LOCK-OUT
LBF	LAMPADA SEGNALAZIONE BASSA FIAMMA BRUCIATORE	BURNER IN LOW FLAME INDICATOR LIGHT
LBF1	LAMPADA SEGNALAZIONE BASSA FIAMMA BRUCIATORE	BURNER IN LOW FLAME INDICATOR LIGHT
LEV1	LAMPADA SEGNALAZIONE APERTURA [EV1]	INDICATOR LIGHT FOR OPENING OF ELECTRO-VALVE [EV1]
LEV2	LAMPADA SEGNALAZIONE APERTURA [EV2]	INDICATOR LIGHT FOR OPENING OF ELECTRO-VALVE [EV2]
LF	LAMPADA SEGNALAZIONE FUNZIONAMENTO BRUCIATORE	INDICATOR LIGHT BURNER OPERATION
LPG	LAMPADA SEGNALAZIONE PRESENZA GAS IN RETE	INDICATOR LIGHT FOR PRESENCE OF GAS IN THE NETWORK
LTA	LAMPADA SEGNALAZIONE TRASFORMATORE DI ACCENSIONE	IGNITION TRANSFORMER INDICATOR LIGHT
MV	MOTORE VENTILATORE	FAN MOTOR
PA	PRESSOSTATO ARIA	AIR PRESSURE SWITCH
PG	PRESSOSTATO GAS DI MINIMA PRESSIONE	MINIMUM GAS PRESSURE SWITCH
PS	PULSANTE SBLOCCO FIAMMA	FLAME UNLOCK BUTTON
PT100	SONDA DI TEMPERATURA	TEMPERATURE PROBE
RC	CIRCUITO RC	RC CIRCUIT
SD-PRESS	SONDA DI PRESSIONE	PRESSURE PROBE
SD-TEMP.	SONDA DI TEMPERATURA	TEMPERATURE PROBE
SD - 0÷10V	TRASDUTTORE USCITA IN TENSIONE	TRANSDUCER VOLTAGE OUTPUT
SD - 4÷20mA	TRASDUTTORE USCITA IN CORRENTE	TRANSDUCER CURRENT OUTPUT
SIEMENS LGB2x.330/LME2x.33x	APPARECCHIATURA CONTROLLO FIAMMA	CONTROL BOX
SIEMENS LME22.331	APPARECCHIATURA CONTROLLO FIAMMA	CONTROL BOX
SIEMENS RWF50.2x	REGOLATORE MODULANTE	BURNER MODULATOR
SIEMENS RWF55.5x	REGOLATORE MODULANTE (ALTERNATIVO)	BURNER MODULATOR (ALTERNATIVE)
SIEMENS SQN72.4A4A20	SERVOCOMANDO SERRANDA ARIA (ALTERNATIVO)	AIR DAMPER ACTUATOR (ALTERNATIVE)
SMA	SELETTORE MANUALE/AUTOMATICO	MANUAL/AUTOMATIC SWITCH
SMF	SELETTORE MANUALE FUNZIONAMENTO MIN-0-MAX	MIN-0-MAX MANUAL OPERATION SWITCH
ST	SERIE TERMOSTATI/PRESSOSTATI	SERIES OF THERMOSTATS OR PRESSURE SWITCHES
STA13B0.36/83N30L	SERVOCOMANDO SERRANDA ARIA	AIR DAMPER ACTUATOR
TA	TRASFORMATORE DI ACCENSIONE	IGNITION TRANSFORMER
TAB	TERMOSTATO/PRESSOSTATO ALTA-BASSA FIAMMA	HIGH-LOW THERMOSTAT/PRESSURE SWITCHES
TC	TERMOCOPPIA	THERMOCOUPLE
TS	TERMOSTATO/PRESSOSTATO DI SICUREZZA	SAFETY THERMOSTAT OR PRESSURE SWITCH
VPS50x	CONTROLLO DI TENUTA VALVOLE GAS (OPTIONAL)	GAS PROVING SYSTEM (OPTIONAL)

Data	19/10/2010	PREC.	FOGLIO
Revisione	05	4	5
Dis. N.	18 - 0163	SEGUE	TOTALE
		/	5

# VERSIONE MONOSTADIO "TN" "TN" SINGLE-STAGE VERSION

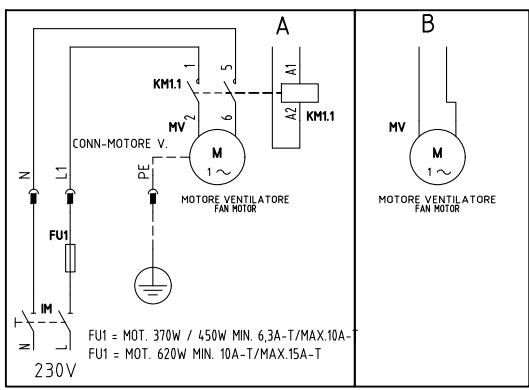
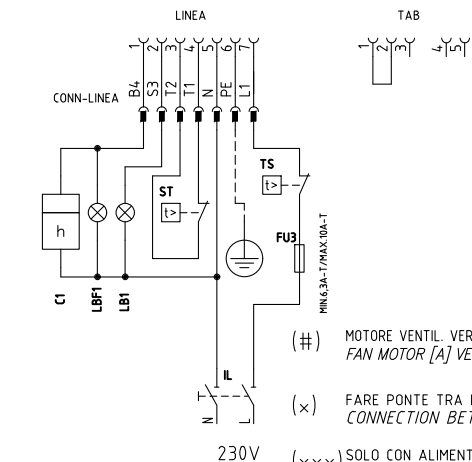
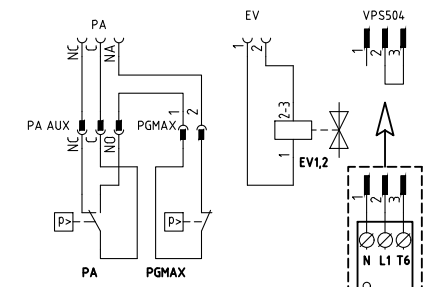
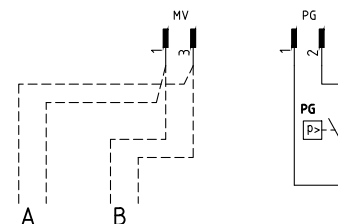
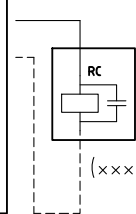
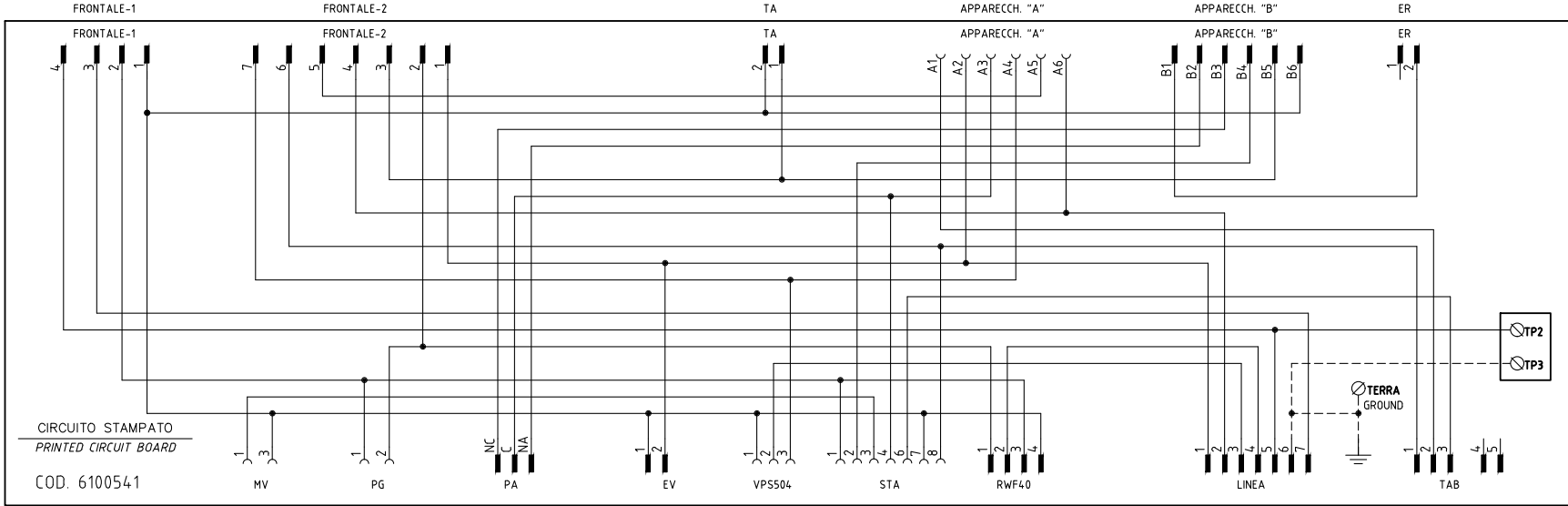
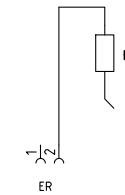
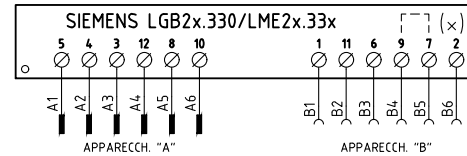
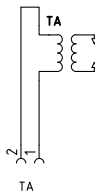
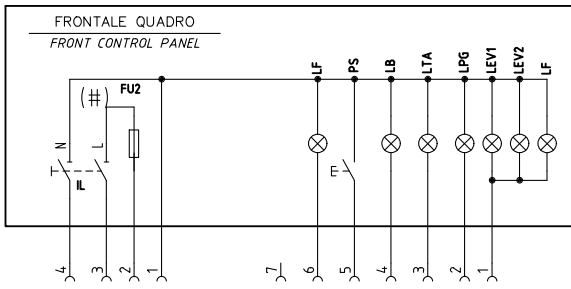

- (#) MOTORE VENTIL. VERSIONE [A], FU2 = 6,3A F; MOTORE VENTIL. VERSIONE [B], FU2 = 10A F  
FAN MOTOR [A] VERSION, FU2 = 6,3A F; FAN MOTOR [B] VERSION FU2 = 10A F
- (x) FARE PONTE TRA I MORSETTI 7 E 9 SOLO CON LGB21.330  
CONNECTION BETWEEN TERMINALS 7 AND 9 WITH LGB21.330 ONLY
- (xxx) SOLO CON ALIMENTAZIONE ELETTRICA SENZA NEUTRO  
WITH ELECTRIC SUPPLY WITHOUT NEUTRAL VERSION ONLY

Data	14/01/2005	PREC.	FOGLIO
Revisione	07	/	1
Dis. N.	18 - 0057	SEGUE	TOTALE
		2	5

VERSIONE ALTA-BASSA FIAMMA "AB" / PROGRESSIVO "PR"  
 "AB" HIGH-LOW / "PR" PROGRESSIVE VERSION

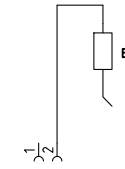
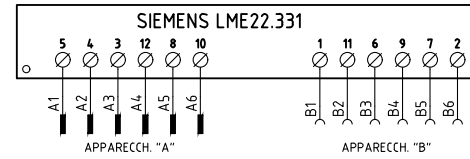
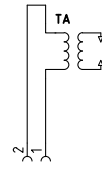
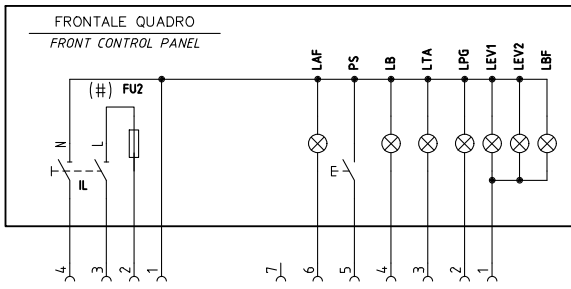

SERVOCOMANDO SERRANDA ARIA  
 AIR DAMPER ACTUATOR  
 STA13B0.36/83N30L

I ALTA FIAMMA  
 HIGH FLAME  
 II SOSTA  
 STAND-BY  
 III BASSA FIAMMA  
 LOW FLAME  
 IV NON USATA  
 NOT USED

SERVOCOMANDO SERRANDA ARIA  
 AIR DAMPER ACTUATOR  
 SIEMENS SQNT2.xA4A20

I (ROSSO) ALTA FIAMMA  
 HIGH FLAME  
 II (VERDE) SOSTA  
 STAND-BY  
 III (BLU) BASSA FIAMMA  
 LOW FLAME  
 IV (ARANCIO) BASSA FIAMMA  
 LOW FLAME  
 V (NERO) NON USATA  
 NOT USED

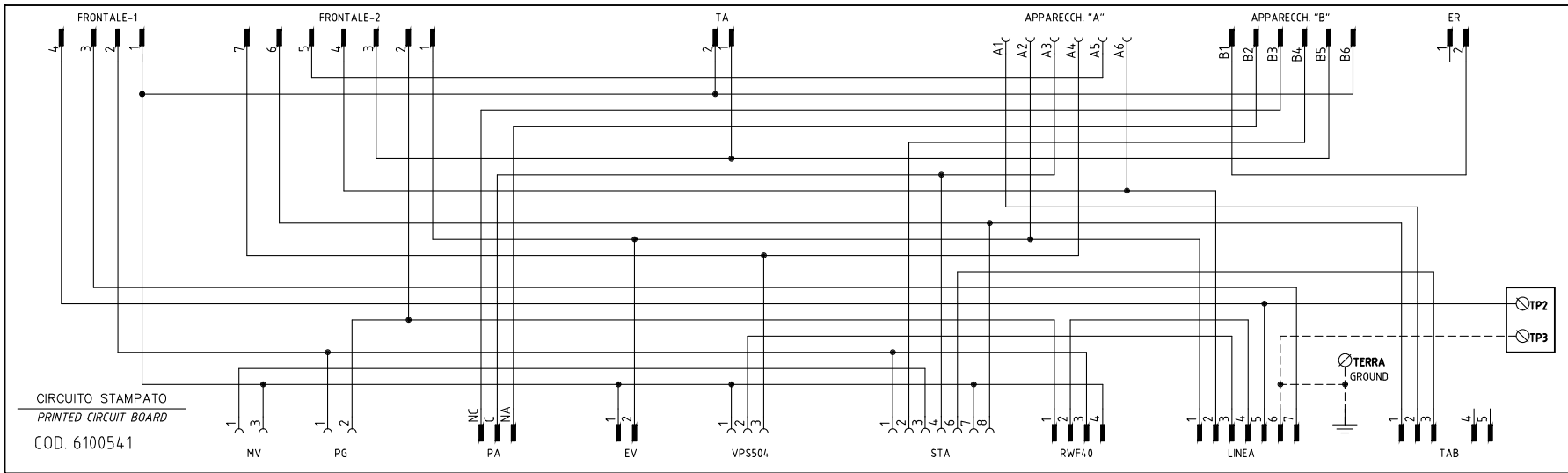

COD. 6100541

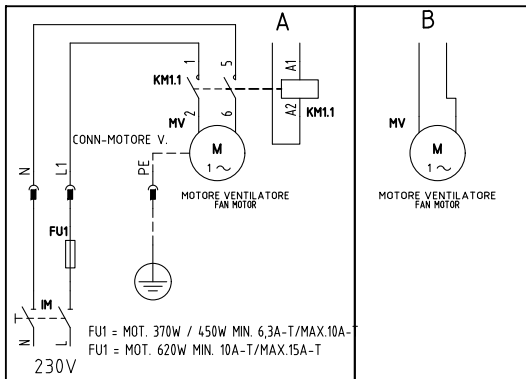
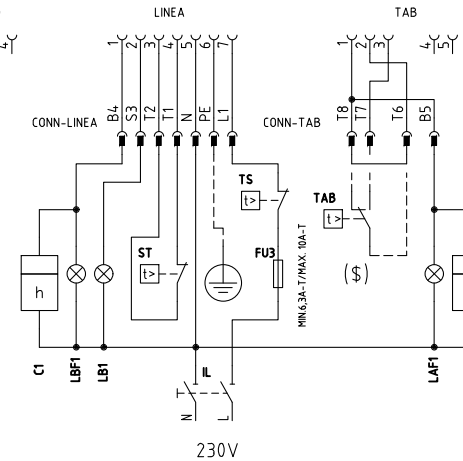
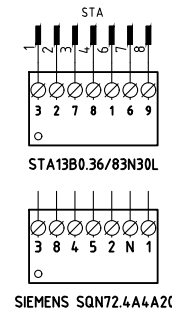
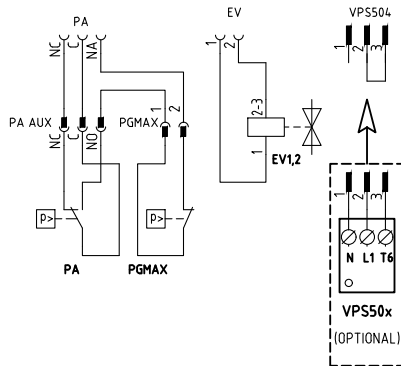
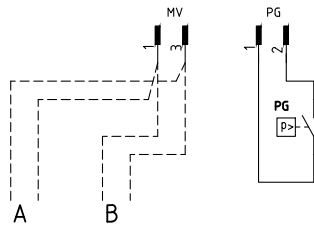

(#) MOTORE VENTIL. VERSIONE [A], FU2 = 6,3A F; MOTORE VENTIL. VERSIONE [B], FU2 = 10A F  
 FAN MOTOR [A] VERSION, FU2 = 6,3A F; FAN MOTOR [B] VERSION FU2 = 10A F

(x x x) SOLO CON ALIMENTAZIONE ELETTRICA SENZA NEUTRO  
 WITH ELECTRIC SUPPLY WITHOUT NEUTRAL VERSION ONLY

(\$) SE USATO "TAB", TOGLIERE IL PONTE TRA I MORSETTI T6-T8  
 IF USED "TAB", REMOVE THE BRIDGE BETWEEN TERMINALS T6-T8

Data	14/01/2005	PREC.	FOGLIO
Revisione	07	1	2
Dis. N.	18 - 0057	SEGUE	TOTALE
		3	5

VERSIONE MODULANTE "MD"  
"MD" MODULATING VERSION

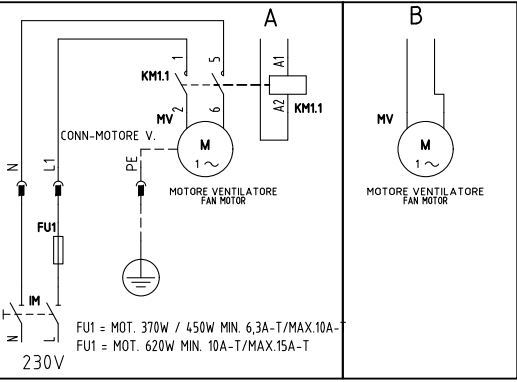
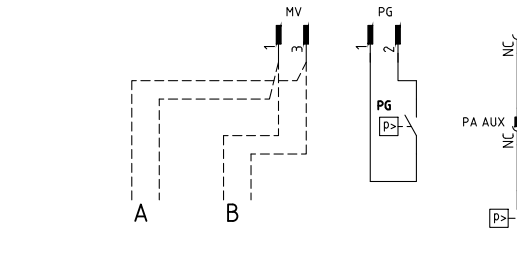
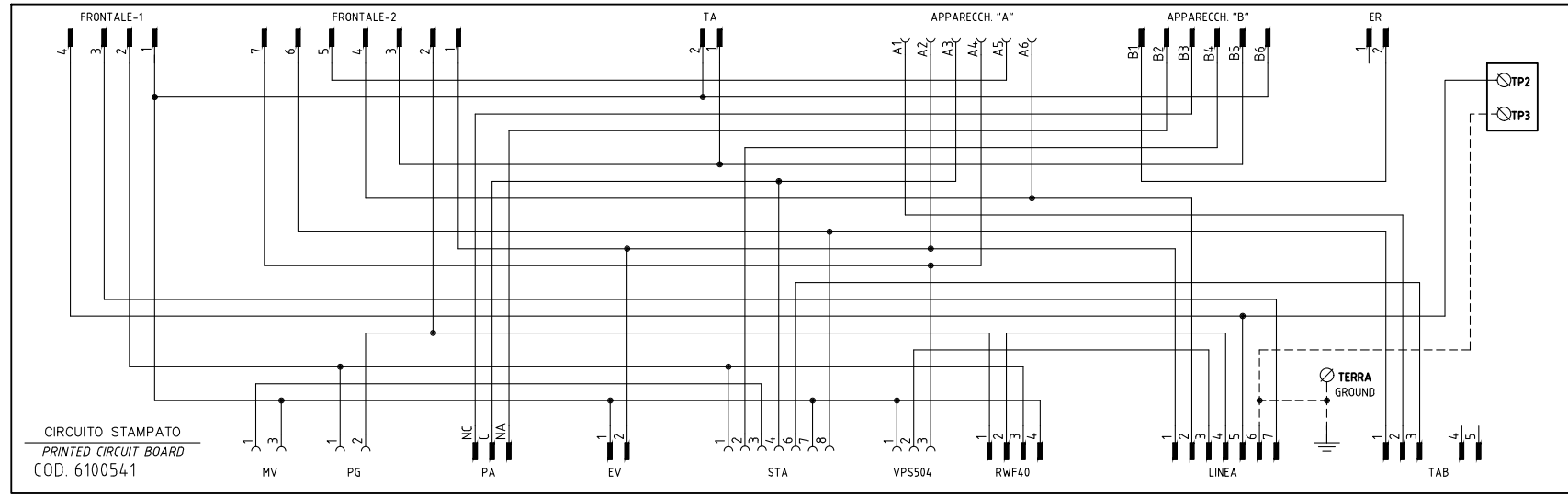
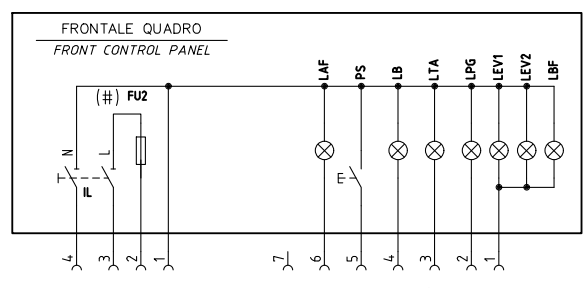

SERVOCOMANDO SERRANDA ARIA  
AIR DAMPER ACTUATOR  
STA13B0.36/83N30L

I ALTA FIAMMA HIGH FLAME  
II SOSTA STAND-BY  
III BASSA FIAMMA LOW FLAME  
IV NON USATA NOT USED

SERVOCOMANDO SERRANDA ARIA  
AIR DAMPER ACTUATOR  
SIEMENS SQN72.xA4.A20

I (ROSSO) ALTA FIAMMA HIGH FLAME  
II (BLU) SOSTA STAND-BY  
III (ARANCIO) BASSA FIAMMA LOW FLAME  
IV (NERO) NON USATA NOT USED

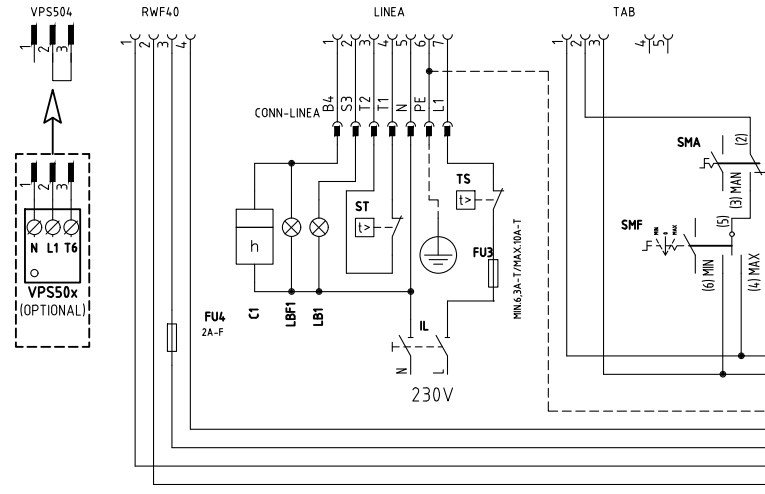
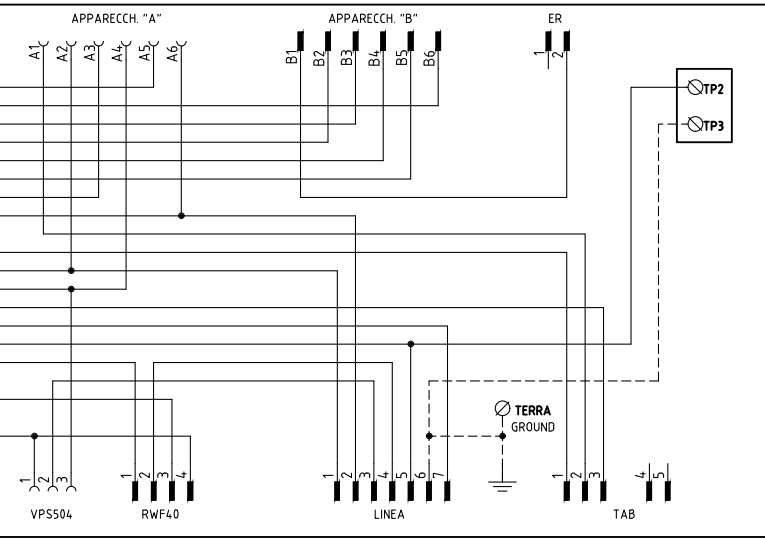
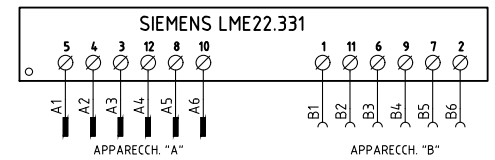

(#) MOTORE VENTIL. VERSIONE [A], FU2 = 6,3A F; MOTORE VENTIL. VERSIONE [B], FU2 = 10A F  
FAN MOTOR [A] VERSION, FU2 = 6,3A F; FAN MOTOR [B] VERSION FU2 = 10A F

(x x x) SOLO CON ALIMENTAZIONE ELETTRICA SENZA NEUTRO  
WITH ELECTRIC SUPPLY WITHOUT NEUTRAL VERSION ONLY

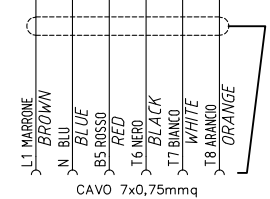
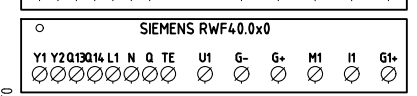
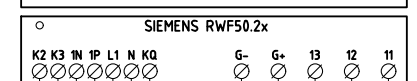
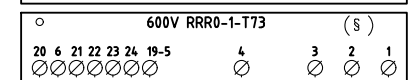
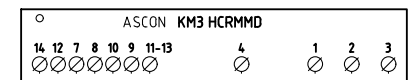
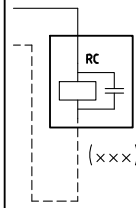

(x x x) COLLEGAMENTO SONDE  
PROBE CONNECTION

Data	14/01/2005	PREC.	FOGLIO
Revisione	07	2	3
Dis. N.	18 - 0057	SEQUE	TOTALE
		4	5

(xx)  
 ATTENZIONE COLLEGAMENTO SONDE CON CONNETTORE 7 POLI  
 WARNING PROBE CONNECTION WITH 7 PINS CONNECTOR

### KM3 HCRMMD

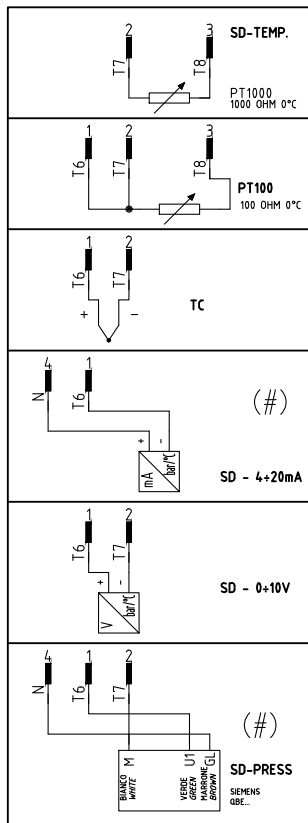

### 600V RRR0-1-T73

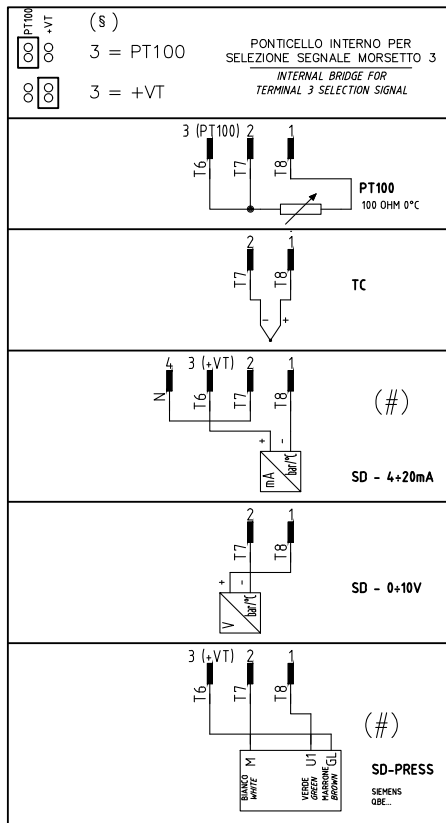

### RWF55.5x

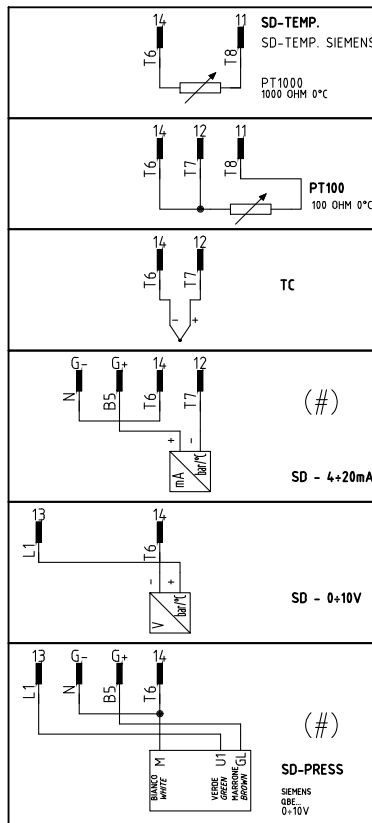

### RWF50.2x

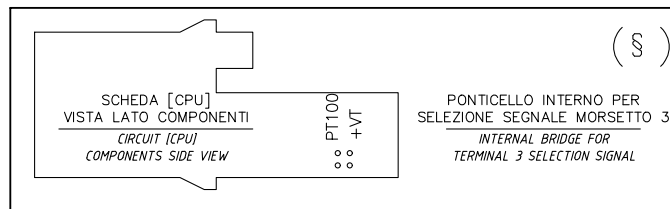
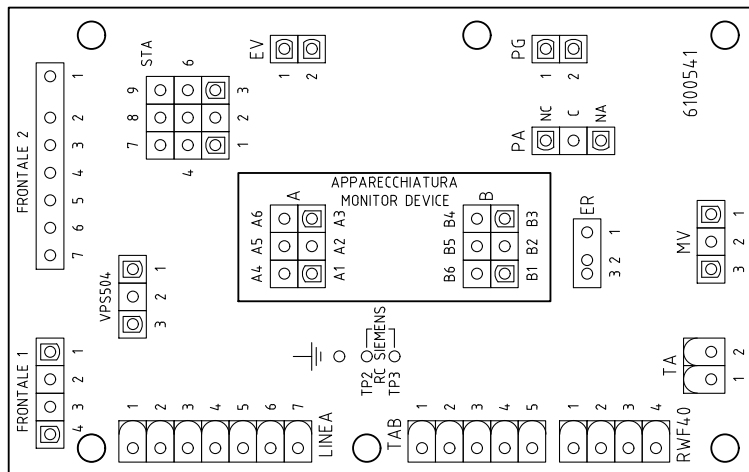
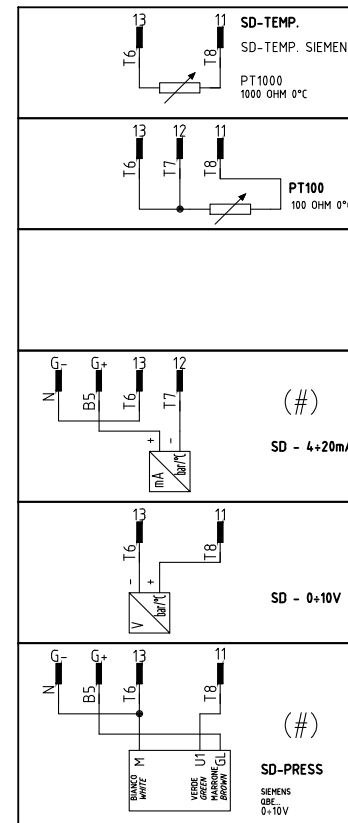

Data	14/01/2005	PREC.	FOGLIO
Revisione	07	3	4
Dis. N.	18 - 0057	SEGUE	TOTALE
		5	5

Sigla/Item	Funzione	Function
PGMAX	PRESSOSTATO GAS DI MASSIMA PRESSIONE	MAXIMUM PRESSURE GAS SWITCH
600V RRR0-1-T73	REGOLATORE MODULANTE (ALTERNATIVO)	BURNER MODULATOR (ALTERNATIVE)
C1	CONTAORE BASSA FIAMMA	LOW FLAME TIME COUNTER
C2	CONTAORE ALTA FIAMMA	HIGH FLAME TIME COUNTER
ER	ELETTRODO RILEVAZIONE FIAMMA	FLAME DETECTION ELECTRODE
EV1,2	ELETTROVALVOLE GAS (O GRUPPO VALVOLE)	GAS ELECTRO-VALVES (OR VALVES GROUP)
FU1	FUSIBILE LINEA MOTORE VENTILATORE	FAN MOTOR LINE FUSE
FU2	FUSIBILE DI LINEA	LINE FUSE
FU3	FUSIBILE DI LINEA	LINE FUSE
FU4	FUSIBILE AUSILIARIO	AUXILIARY FUSE
IL	INTERRUTTORE LINEA BRUCIATORE	BURNER LINE SWITCH
IM	INTERRUTTORE LINEA MOTORE VENTILATORE	FAN MOTOR LINE SWITCH
KM1.1	CONTATTORE MOTORE VENTILATORE	FAN MOTOR CONTACTOR
KM3 HCRMMD	REGOLATORE MODULANTE (ALTERNATIVO)	BURNER MODULATOR (ALTERNATIVE)
LAF	LAMPADA SEGNALAZIONE ALTA FIAMMA BRUCIATORE	BURNER IN HIGH FLAME INDICATOR LIGHT
LAF1	LAMPADA SEGNALAZIONE ALTA FIAMMA BRUCIATORE	BURNER IN HIGH FLAME INDICATOR LIGHT
LB	LAMPADA SEGNALAZIONE BLOCCO BRUCIATORE	INDICATOR LIGHT FOR BURNER LOCK-OUT
LB1	LAMPADA SEGNALAZIONE BLOCCO BRUCIATORE	INDICATOR LIGHT FOR BURNER LOCK-OUT
LBF	LAMPADA SEGNALAZIONE BASSA FIAMMA BRUCIATORE	BURNER IN LOW FLAME INDICATOR LIGHT
LBF1	LAMPADA SEGNALAZIONE BASSA FIAMMA BRUCIATORE	BURNER IN LOW FLAME INDICATOR LIGHT
LEV1	LAMPADA SEGNALAZIONE APERTURA [EV1]	INDICATOR LIGHT FOR OPENING OF ELECTRO-VALVE [EV1]
LEV2	LAMPADA SEGNALAZIONE APERTURA [EV2]	INDICATOR LIGHT FOR OPENING OF ELECTRO-VALVE [EV2]
LF	LAMPADA SEGNALAZIONE FUNZIONAMENTO BRUCIATORE	INDICATOR LIGHT BURNER OPERATION
LPG	LAMPADA SEGNALAZIONE PRESENZA GAS IN RETE	INDICATOR LIGHT FOR PRESENCE OF GAS IN THE NETWORK
LTA	LAMPADA SEGNALAZIONE TRASFORMATORE DI ACCENSIONE	IGNITION TRANSFORMER INDICATOR LIGHT
MV	MOTORE VENTILATORE	FAN MOTOR
PA	PRESSOSTATO ARIA	AIR PRESSURE SWITCH
PG	PRESSOSTATO GAS DI MINIMA PRESSIONE	MINIMUM GAS PRESSURE SWITCH
PS	PULSANTE SBLOCCO FIAMMA	FLAME UNLOCK BUTTON
RC	CIRCUITO RC	RC CIRCUIT
SIEMENS LGB2x.330/LME2x.33x	APPARECCHIATURA CONTROLLO FIAMMA	CONTROL BOX
SIEMENS LME22.331	APPARECCHIATURA CONTROLLO FIAMMA	CONTROL BOX
SIEMENS RWF40.0x0	REGOLATORE MODULANTE	BURNER MODULATOR
SIEMENS RWF50.2x	REGOLATORE MODULANTE (ALTERNATIVO)	BURNER MODULATOR (ALTERNATIVE)
SIEMENS SQN72.4A4A20	SERVOCOMANDO SERRANDA ARIA (ALTERNATIVO)	AIR DAMPER ACTUATOR (ALTERNATIVE)
SMA	SELETTORE MANUALE/AUTOMATICO	MANUAL/AUTOMATIC SWITCH
SMF	SELETTORE MANUALE FUNZIONAMENTO MIN-0-MAX	MIN-0-MAX MANUAL OPERATION SWITCH
ST	SERIE TERMOSTATI/PRESSOSTATI	SERIES OF THERMOSTATS OR PRESSURE SWITCHES
STA13B0.36/83N30L	SERVOCOMANDO SERRANDA ARIA	AIR DAMPER ACTUATOR
TA	TRASFORMATORE DI ACCENSIONE	IGNITION TRANSFORMER
TAB	TERMOSTATO/PRESSOSTATO ALTA-BASSA FIAMMA	HIGH-LOW THERMOSTAT/PRESSURE SWITCHES
TS	TERMOSTATO/PRESSOSTATO DI SICUREZZA	SAFETY THERMOSTAT OR PRESSURE SWITCH
VPS50x	CONTROLLO DI TENUTA VALVOLE GAS (OPTIONAL)	GAS PROVING SYSTEM (OPTIONAL)

Data	14/01/2005	PREC.	FOGLIO
Revisione	07	4	5
Dis. N.	18 - 0057	SEGUE	TOTALE
		/	5

VERSIONE ALTA-BASSA FIAMMA / PROGRESSIVO CON RELE' "KAB" DI SEZIONAMENTO  
 HIGH-LOW / PROGRESSIVE VERSION WITH "KAB" SECTIONING RELAY  
 ИСПОЛНЕНИЕ ДВУХСТУПЕНЧАТОЕ / ПРОГРЕССИВНОЕ С РАЗДЕЛИТЕЛЬНЫМ РЕЛЕ «КАВ»

CONNETTORE [3] POLI  
 [3] PINS CONNECTOR  
 [3]-ТИ ПОЛЮСНЫЙ СОЕДИНИТЕЛЬНЫЙ РАЗЪЕМ

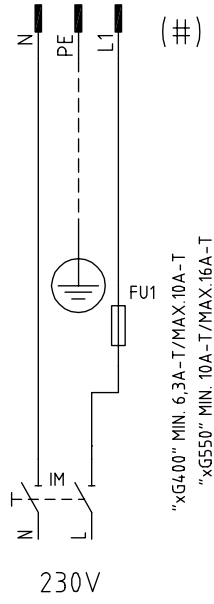

(#) ESCLUSO TIPO [xG350]  
 EXCLUDED TYPE [xG350]  
 ЗА ИСКЛЮЧЕНИЕМ ТИПА [xG350]

CONNETTORE [7] POLI  
 [7] PINS CONNECTOR  
 [7]-ТИ ПОЛЮСНЫЙ СОЕДИНИТЕЛЬНЫЙ РАЗЪЕМ

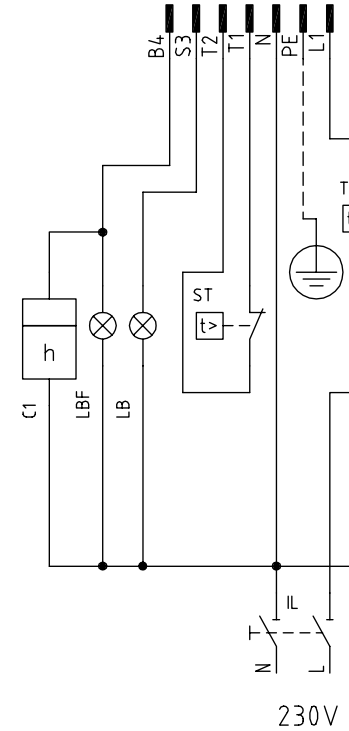

CONNETTORE [4] POLI  
 [4] PINS CONNECTOR  
 [4]-ТИ ПОЛЮСНЫЙ СОЕДИНИТЕЛЬНЫЙ РАЗЪЕМ

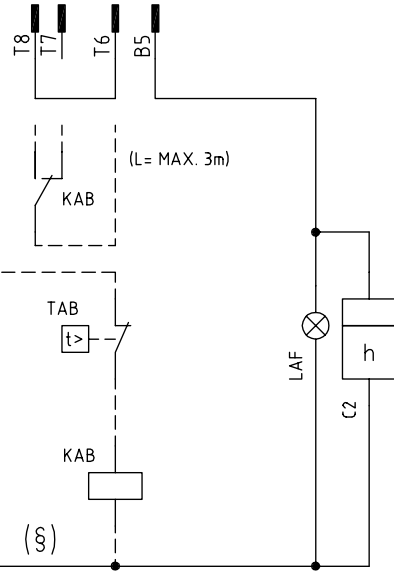

(§) SE USATO, TOGLIERE IL PONTE TRA I MORSETTI T6-T8  
 IF USED, REMOVE THE BRIDGE BETWEEN TERMINALS T6-T8  
 ЕСЛИ ИСПОЛЬЗУЕТСЯ, СНЯТЬ ПЕРЕМЫЧКУ МЕЖДУ КЛЕММАМИ T6 - T8

Data	26/06/2008	PREC.	FOGLIO
Revisione	00	/	1
Dis. N.	TAB_1	SEGUE	TOTALE
		2	1

SIGLA/ITEM	FUNZIONE	FUNCTION
C1	CONTAORE BASSA FIAMMA	LOW FLAME TIME COUNTER
C2	CONTAORE ALTA FIAMMA	HIGH FLAME TIME COUNTER
FU1	FUSIBILE LINEA MOTORE VENTILATORE	FAN MOTOR LINE FUSE
FU3	FUSIBILE LINEA BRUCIATORE	BURNER LINE FUSE
IL	INTERRUTTORE LINEA BRUCIATORE	BURNER LINE SWITCH
IM	INTERRUTTORE LINEA MOTORE VENTILATORE	FAN MOTOR LINE SWITCH
KAB	RELE' AUSILIARIO	AUXILIARY RELAY
LAF	LAMPADA SEGNALAZIONE ALTA FIAMMA BRUCIATORE	BURNER IN HIGH FLAME INDICATOR LIGHT
LB	LAMPADA SEGNALAZIONE BLOCCO BRUCIATORE	INDICATOR LIGHT FOR BURNER LOCK-OUT
LBF	LAMPADA SEGNALAZIONE BASSA FIAMMA BRUCIATORE	BURNER IN LOW FLAME INDICATOR LIGHT
ST	SERIE TERMOSTATI/PRESSOSTATI	SERIES OF THERMOSTATS OR PRESSURE SWITCHES
TAB	TERMOSTATO/PRESSOSTATO ALTA-BASSA FIAMMA	HIGH-LOW THERMOSTAT/PRESSURE SWITCHES
TS	TERMOSTATO/PRESSOSTATO DI SICUREZZA	SAFETY THERMOSTAT OR PRESSURE SWITCH

SIGLA/ITEM	FUNZIONE	FUNCTION
C1	CONTAORE BASSA FIAMMA	СЧЕТЧИК ЧАСОВ РАБОТЫ НА МАЛОМ ПЛАМЕНИ
C2	CONTAORE ALTA FIAMMA	СЧЕТЧИК ЧАСОВ РАБОТЫ НА БОЛЬШОМ ПЛАМЕНИ
FU1	FUSIBILE LINEA MOTORE VENTILATORE	ПЛАВКИЙ ПРЕДОХРАНИТЕЛЬ ЛИНИИ ДВИГАТЕЛЯ ВЕНТИЛЯТОРА
FU3	FUSIBILE LINEA BRUCIATORE	ПЛАВКИЙ ПРЕДОХРАНИТЕЛЬ ЛИНИИ ГОРЕЛКИ
IL	INTERRUTTORE LINEA BRUCIATORE	ВЫКЛЮЧАТЕЛЬ ЛИНИИ ГОРЕЛКИ
IM	INTERRUTTORE LINEA MOTORE VENTILATORE	ВЫКЛЮЧАТЕЛЬ ЛИНИИ ДВИГАТЕЛЯ ВЕНТИЛЯТОРА
KAB	RELE' AUSILIARIO	ВСПОМОГАТЕЛЬНОЕ РЕЛЕ
LAF	LAMPADA SEGNALAZIONE ALTA FIAMMA BRUCIATORE	СИГНАЛЬНАЯ ЛАМПОЧКА БОЛЬШОГО ПЛАМЕНИ ГОРЕЛКИ
LB	LAMPADA SEGNALAZIONE BLOCCO BRUCIATORE	СИГНАЛЬНАЯ ЛАМПОЧКА БЛОКИРОВКИ ГОРЕЛКИ
LBF	LAMPADA SEGNALAZIONE BASSA FIAMMA BRUCIATORE	СИГНАЛЬНАЯ ЛАМПОЧКА МАЛОГО ПЛАМЕНИ ГОРЕЛКИ
ST	SERIE TERMOSTATI/PRESSOSTATI	РЯД ТЕРМОСТАТОВ/РЕЛЕ ДАВЛЕНИЯ
TAB	TERMOSTATO/PRESSOSTATO ALTA-BASSA FIAMMA	ТЕРМОСТАТ/РЕЛЕ ДАВЛЕНИЯ БОЛЬШОГО/МАЛОГО ПЛАМЕНИ
TS	TERMOSTATO/PRESSOSTATO DI SICUREZZA	ПРЕДОХРАНИТЕЛЬНЫЙ ТЕРМОСТАТ/ РЕЛЕ ДАВЛЕНИЯ

Data	26/06/2008	PREC.	FOGLIO
Revisione	00	1	2
Dis. N.	TAB_1	SEGUE	TOTALE
		/	1







## USER'S MANUAL

COD. M12925CA Rel 1.2 08/2014

SOFTWARE VERSION 1.0x T73  
code 80379 / Edition 01 - 06/2012



## 1 • INSTALLATION

### • Dimensions and cut-out; panel mounting

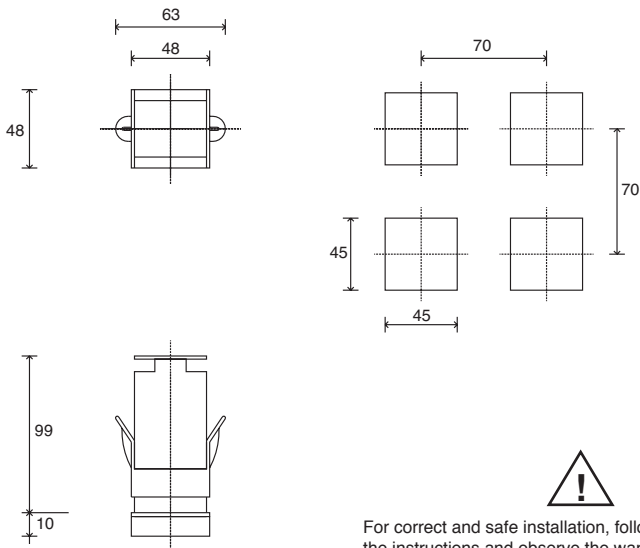

For correct and safe installation, follow the instructions and observe the warnings contained in this manual.

#### Panel mounting:

To fix the unit, insert the brackets provided into the seats on either side of the case. To mount two or more units side by side, respect the cut-out dimensions shown in the drawing.

**CE MARKING:** The instrument conforms to the European Directives 2004/108/CE and 2006/95/CE with reference to the generic standards: **EN 61000-6-2** (immunity in industrial environment) **EN 61000-6-3** (emission in residential environment) **EN 61010-1** (safety).

**MAINTENANCE:** Repairs must be done only by trained and specialized personnel.

Cut power to the device before accessing internal parts.

Do not clean the case with hydrocarbon-based solvents (Petrol, Trichlorethylene, etc.). Use of these solvents can reduce the mechanical reliability of the device. Use a cloth dampened in ethyl alcohol or water to clean the external plastic case.

**SERVICE:** GEFRA has a service department. The warranty excludes defects caused by any use not conforming to these instructions.

EMC conformity has been tested with the following connections

FUNCTION	CABLE TYPE	LENGTH
Power supply cable	1 mm <sup>2</sup>	1 m
Relay output cable	1 mm <sup>2</sup>	3,5 m
TC input	0,8 mm <sup>2</sup> compensated	5 m
Pt100 input	1 mm <sup>2</sup>	3 m

## 2 • TECHNICAL SPECIFICATIONS

Display	2x4 digit green, high display 10 and 7mm
Keys	4 of mechanical type (Man/Aut, INC, DEC, F)
Accuracy	0.2% f.s. ±1 digit ambient temperature 25°C
Main input (settable digital filter)	TC, RTD, PTC, NTC 60mV, 1V Ri≥1MΩ; 5V, 10V Ri≥10KΩ; 20mA Ri=50Ω Tempo di campionamento 120 msec.
Type TC Thermocouples (ITS90)	Type TC Thermocouples : J,K,R,S,T (IEC 584-1, CEI EN 60584-1, 60584-2) ; custom linearization is available / types B,E,N,L GOST,U,G,D,C are available by using the custom linearization.
Cold junction error	0,1° / °C
RTD type (scale configurable within indicated range, with or without decimal point) (ITS90) Max line resistance for RTD	DIN 43760 (Pt100), JPT100 20Ω
PTC type / NTC Type	990Ω, 25°C / 1KΩ, 25°C
Safety	detection of short-circuit or opening of probes, LBA alarm
°C / °F selection	configurable from faceplate
Linear scale ranges	-1999 to 9999 with configurable decimal point position
Controls	PID, Self-tuning, on-off
pb - dt - it	0,0...999,9 % - 0,00...99,99 min - 0,00...99,99 min
Action	Heat / Cool
Control outputs	on / off
Maximum power limit heat / cool	0,0...100,0 %
Cycle time	0...200 sec
Main output type	relay, logic, continuous (0...10V Rload ≥ 250KΩ, 0/4...20mA Rload ≤ 500Ω)
Softstart	0,0...500,0 min
Fault power setting	-100,0...100,0 %
Automatic blanking	Displays PV value, optional exclusion
Configurable alarms	Up to 3 alarm functions assignable to an output, configurable as: maximum, minimum, symmetrical, absolute/deviation, LBA
Alarm masking	- exclusion during warm up - latching reset from faceplate or external contact
Type of relay contact	NO (NC), 5A, 250V/30Vdc cosφ=1
Logic output for static relays	24V ±10% (10V min at 20mA)
Transmitter power supply	15/24Vdc, max 30mA short-circuit protection
Power supply (switching type)	(std) 100 ... 240Vac ±10% (opt.) 11...27Vac/dc ±10%; 50/60Hz, 8VA max
Faceplate protection	IP65
Working / Storage temperature range	0...50°C / -20...70°C
Relative humidity	20 ... 85% non-condensing
Environmental conditions of use	for internal use only, altitude up to 2000m
Installation	Panel, plug-in from front
Weight	160g for the complete version

### 3 · DESCRIPTION OF FACEPLATE

**Function indicators**  
Indicates modes of operation

L1 MAN/AUTO = OFF (automatic control)  
ON (manual control)

L2 PRE-HEATING = ON (running)

L3 SELFTUNING = ON (enabled Self)  
OFF (disabled Self)

**Automatic/Manual adjustment selection**  
Active only when PV display visualises the process variable (button pressed for at least 5 sec.)

**"Inc" and "Dec" key**  
Press to increment (decrement) any numerical parameter •• Increment (decrement) speed is proportional to time key stays pressed •• The operation is not cyclic: once the maximum (minimum) value of a field is reached, the value will not change even if the key remains pressed.

**Indication of output states**  
OUT 1 (AL1); OUT 2 (OPEN); OUT 3 (CLOSED)

**PV Display:** Indication of process variable  
Error Indication: LO, HI, Sbr, Err  
**LO**= the value of process variable is < di LO\_S  
**HI**= the value of process variable is > di HI\_S  
**Sbr**= faulty sensor or input values higher than max. limits  
**Err**= PT100 third wire opened for PT100, PTC or input values lower than min. limits (i.e.: TC wrong connection)

**SV display:** Indication of setpoint

**Function key**  
Gives access to the various configuration phases •• Confirms change of set parameters and browses next or previous parameter (if Auto/Man key is pressed)

### 4 · CONNECTIONS

**• Outputs**

Out2 (19, 20) - 5A at 250Vac/30Vdc relay

Out1 (21, 22) - 5A/250Vac relay

Out3 (6, 5) - 5A at 250Vac/30Vdc relay

TOP

**• Inputs**

**• TC Input**  
Available thermocouples: J, K, R, S, T (B, E, N, L, U, G, D, C custom linearization is available)  
- Observe polarities  
- For extensions, use the correct compensating cable for the type of TC used

**• Linear input with 3-wire transmitter**  
Connect at 20mA input

**• Power Supply**

Standard: 100...240Vac ± 10%

Optional: 11...27Vac/Vdc ± 10%

Max. power 8VA; 50/60 Hz

**• Linear input (I)**

Linear input in dc current  
20mA, Ri = 50Ω

**• Input 1 linear with transmitter 2 wires**

**• Identification of boards**

Power board - Solder side

Select transmitter voltage

**N.B. :** you can keep the **OUT1** relay energized at power-up by inserting jumper **S2** and removing resistance **R20**.

CPU board - Component side

IN/OUT boards (see appendix)

Select signal at contact 3

**• Linear input (V)**

Linear input in dc voltage  
60mV, 1V  
Ri > 1MΩ  
5V, 10V  
Ri > 10KΩ

**• Pt100 / PTC / NTC**

Use wires of adequate diameter (min. 1mm²)  
PT100, JPT100, PTC, NTC

**• Device structure**

# 5 • “EASY” PROGRAMMING and CONFIGURATION

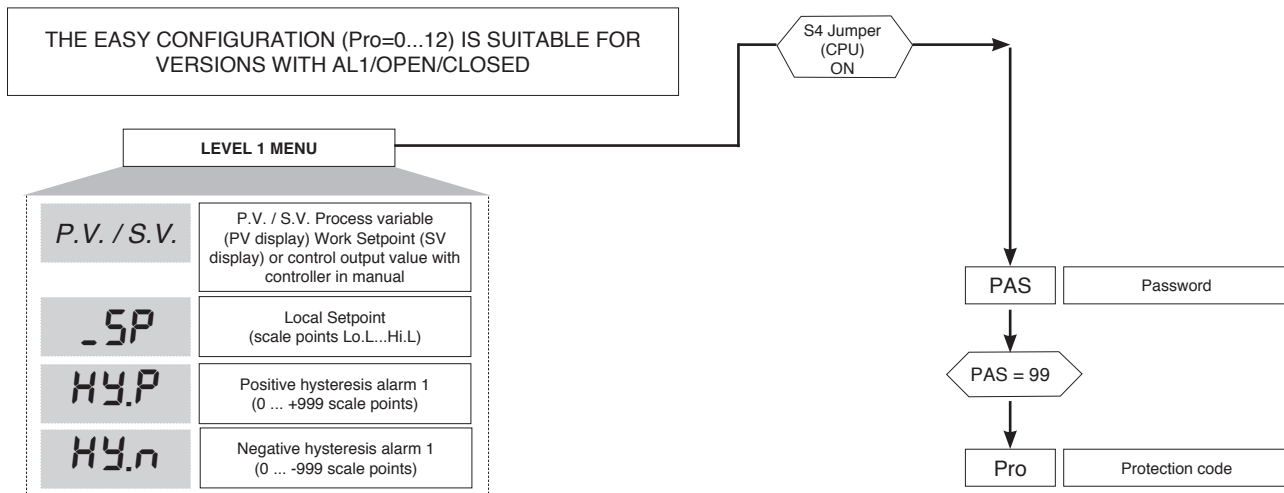

## • Prot

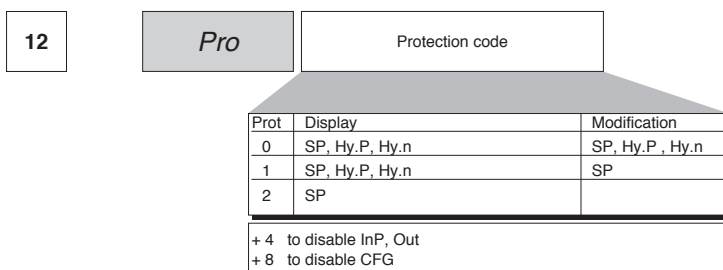

# 6 • PROGRAMMING and CONFIGURATION

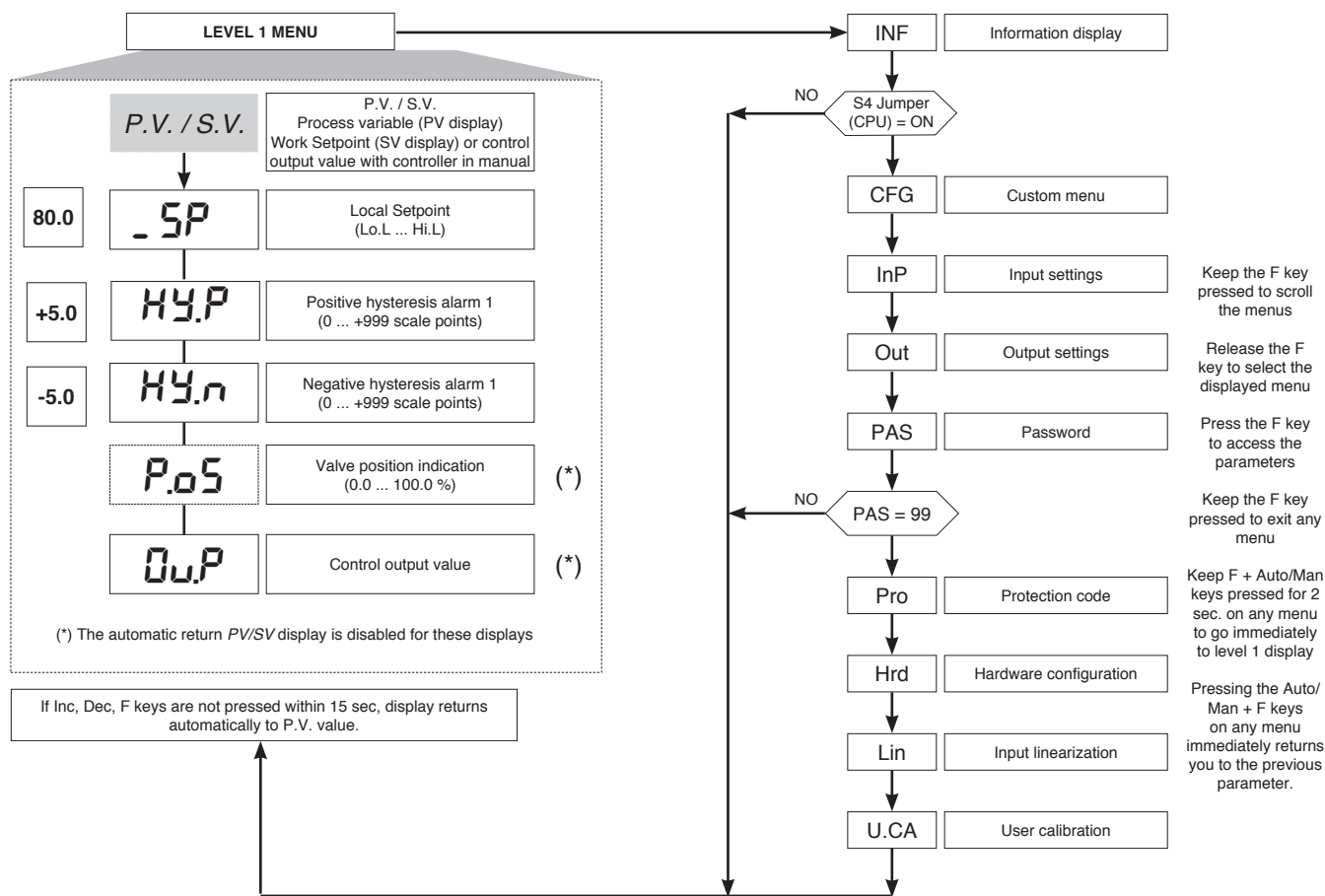

**N.B.:** Once a particular configuration is entered, all unnecessary parameters are no longer displayed

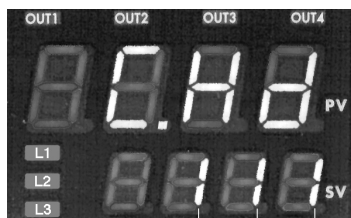

<b>OUTPUT 2</b>	<b>OUTPUT 3</b>	<b>SERIAL COMMUNICATION</b>
0 = None	0 = None	0 = None
1 = Relay	1 = Relay	

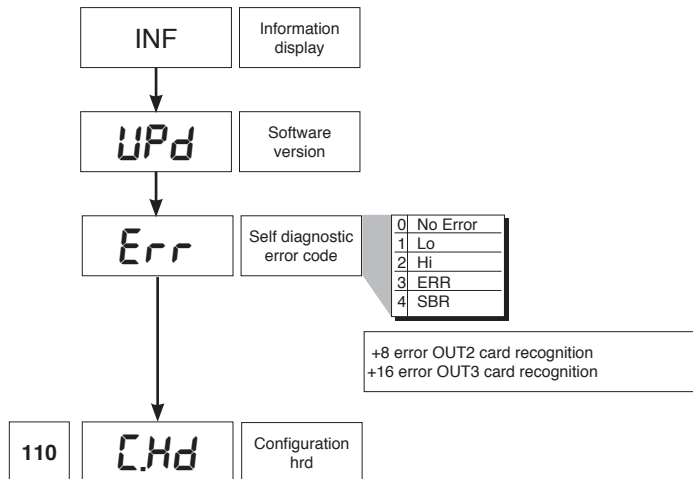

• CFG

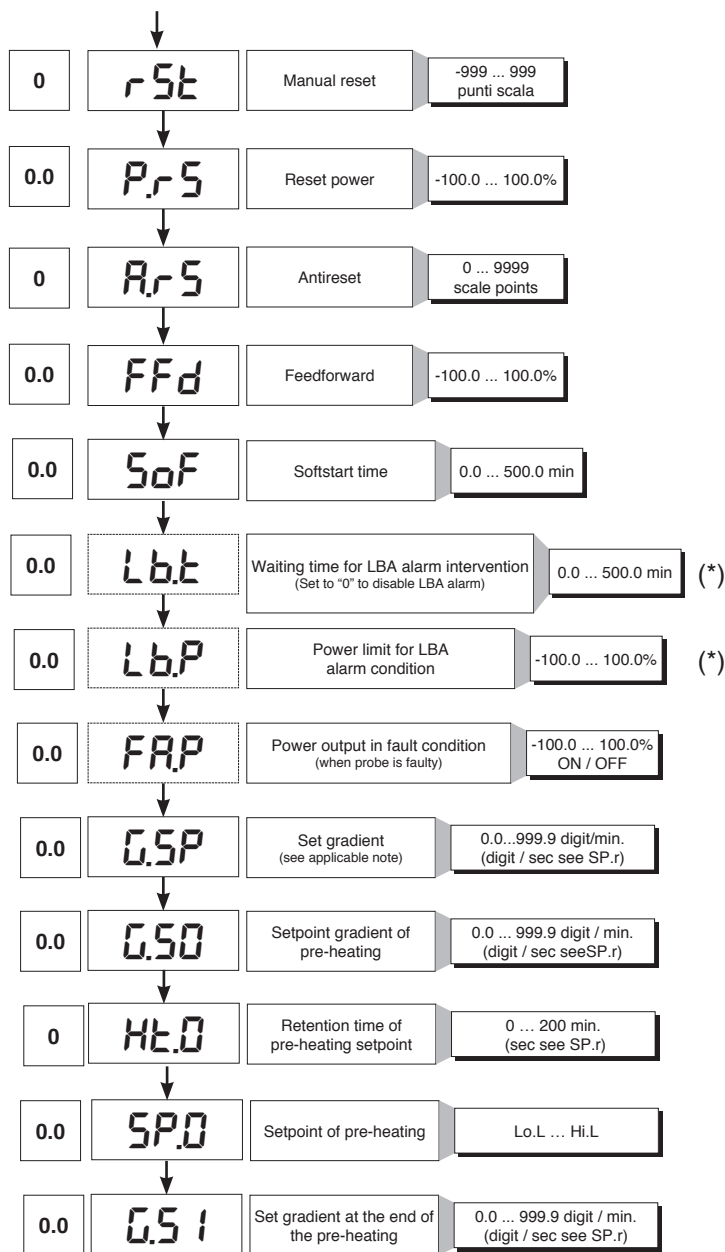
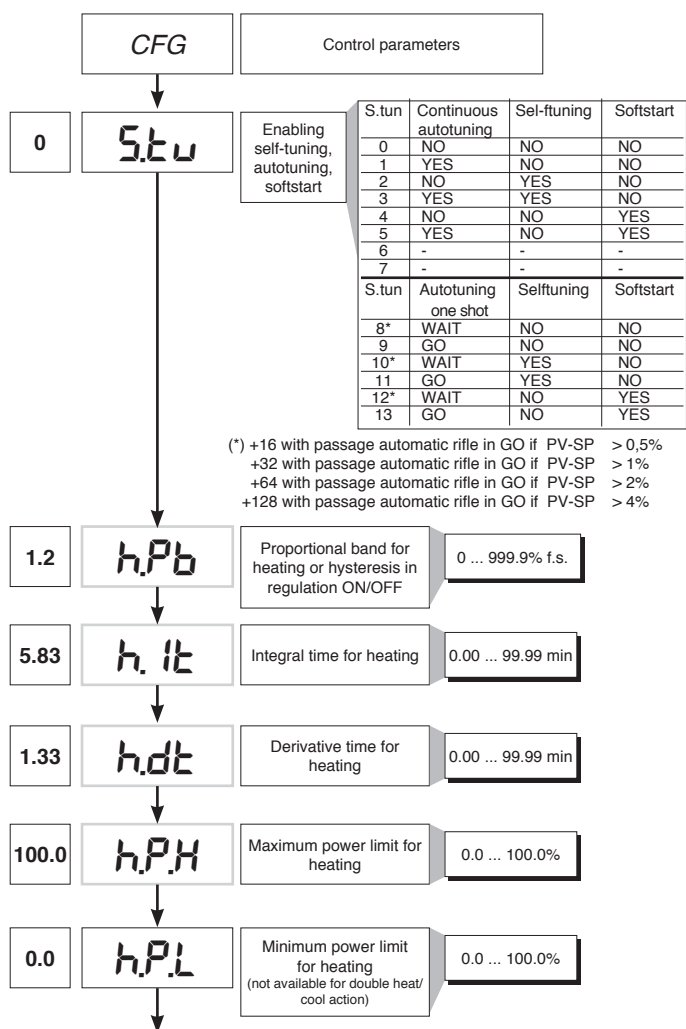

(\*) LBA alarm may be reset by simultaneously pressing Δ + ▽ keys when OutP is displayed or by switching to Manual.

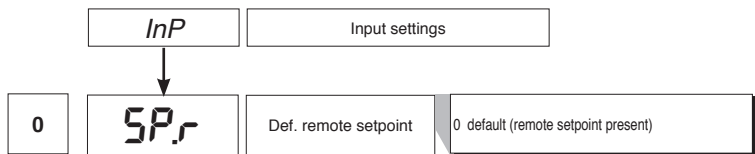

+2 Times of pre-heating and gradients of set digit/sec

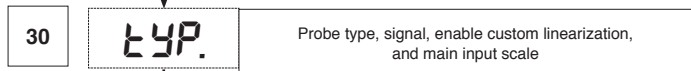

Type	Probe type	without decimal point	with decimal point
Sensore:			
TC			
0	TC J °C	0/1000	0.0/999.9
1	TC J °F	32/1832	32.0/999.9
2	TC K °C	0/1300	0.0/999.9
3	TC K °F	32/2372	32.0/999.9
4	TC R °C	0/1750	0.0/999.9
5	TC R °F	32/3182	32.0/999.9
6	TC S °C	0/1750	0.0/999.9
7	TC S °F	32/3182	32.0/999.9
8	TC T °C	-200/400	-199.9/400.0
9	TC T °F	-328/752	-199.9/752.0
28	TC	CUSTOM	CUSTOM
29	TC	CUSTOM	CUSTOM
30	PT100 °C	-200/850	-199.9/850.0
31	PT100 °F	-328/156.2	-199.9/999.9
32	JPT100 °C	-200/600	-199.9/600.0
33	JPT100 °F	-328/1112	-199.9/999.9
34	PTC °C	-55/120	-55.0/120.0
35	PTC °F	-67/248	-67.0/248.0
36	NTC °C	-10/70	-10.0/70.0
37	NTC °F	14/158	14.0/158.0
38	0...60 mV	-1999/9999	-199.9/999.9
39	0...60 mV	Custom scale	Custom scale
40	12...60 mV	-1999/9999	-199.9/999.9
41	12...60 mV	Custom scale	Custom scale
42	0...20 mA	-1999/9999	-199.9/999.9
43	0...20 mA	Custom scale	Custom scale
44	4...20 mA	-1999/9999	-199.9/999.9
45	4...20 mA	Custom scale	Custom scale
46	0...10 V	-1999/9999	-199.9/999.9
47	0...10 V	Custom scale	Custom scale
48	2...10 V	-1999/9999	-199.9/999.9
49	2...10 V	Custom scale	Custom scale
50	0...5 V	-1999/9999	-199.9/999.9
51	0...5 V	Custom scale	Custom scale
52	1...5 V	-1999/9999	-199.9/999.9
53	1...5 V	Custom scale	Custom scale
54	0...1 V	-1999/9999	-199.9/999.9
55	0...1 V	Custom scale	Custom scale
56	200mv...1V	-1999/9999	-199.9/999.9
57	200mv...1V	Custom scale	Custom scale
58	Cust10 V-20mA	-1999/9999	-199.9/999.9
59	Cust10 V-20mA	Custom scale	Custom scale
60	Cust 60mV	-1999/9999	-199.9/999.9
61	Cust 60mV	Custom scale	Custom scale
62	PT100-JPT	CUSTOM	CUSTOM
63	PTC	CUSTOM	CUSTOM
64	NTC	CUSTOM	CUSTOM

For custom linearization:  
 - LO signal is generated with variable below Lo.S or at minimum calibration value  
 - HI signal is generated with variable above Lo.S or at maximum calibration value

Max. non-linearity error for thermocouples (TC), resistors (PT100) and thermistors (PTC, NTC).  
 The error is calculated as deviation from theoretical value and is expressed as percentage of full scale (in °C).

**S, R** range 0...1750°C; error < 0.2% f.s. (t > 300°C) / for other range; error < 0.5% f.s.  
**T** error < 0.2% f.s. (t > -150°C)  
**B** range 44...1800°C; error < 0.5% f.s. (t > 300°C) / range 44.0...999.9; error < 1% f.s. (t > 300°C)  
**U** range -99.9...99.9 and -99...99°C; error < 0.5% f.s. / for other range; error < 0.2% f.s. (t > -150°C)  
**G** error < 0.2% f.s. (t > 300°C)  
**D** error < 0.2% f.s. (t > 200°C)  
**C** range 0...2300; error < 0.2% f.s. / for other range; error < 0.5% f.s.

**NTC error < 0.5% f.s.**

Tc: J, K, E, N, L error < 0,2% f.s.  
 JPT100 and PTC error < 0,2% f.s.  
 PT100 scale -200...850°C  
 Precision better than 0,2% f.s. at 25°C  
 In range 0...50°C:  
 • Precision better than 0,2% f.s. in range -200...400°C  
 • Precision better than 0,4% f.s. in range +400...850°C (where f.s. refers to range -200... +850°C)

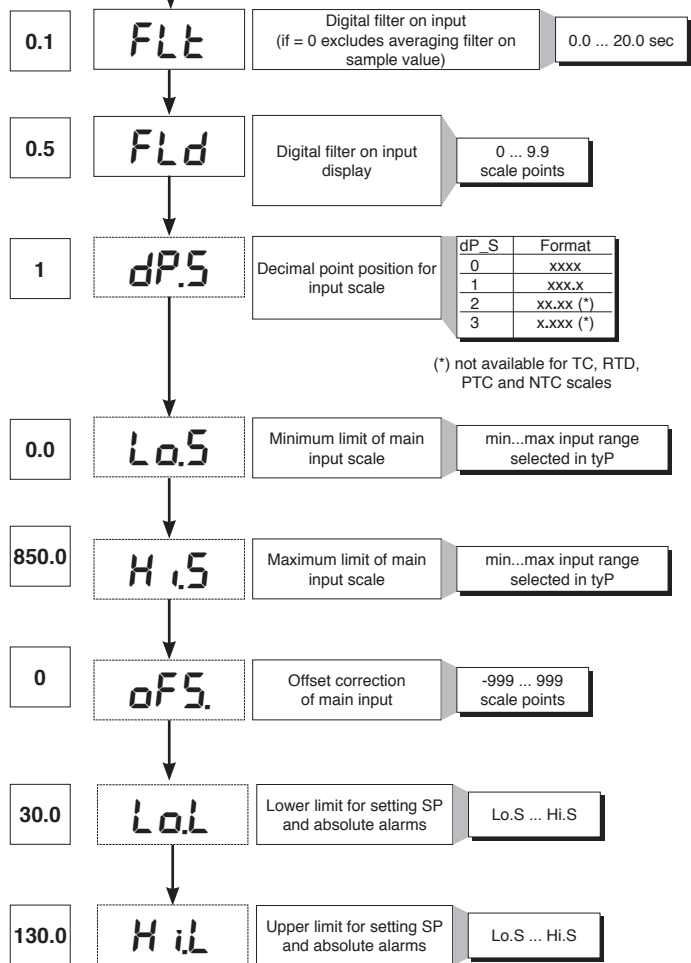

(\* ) not available for TC, RTD, PTC and NTC scales

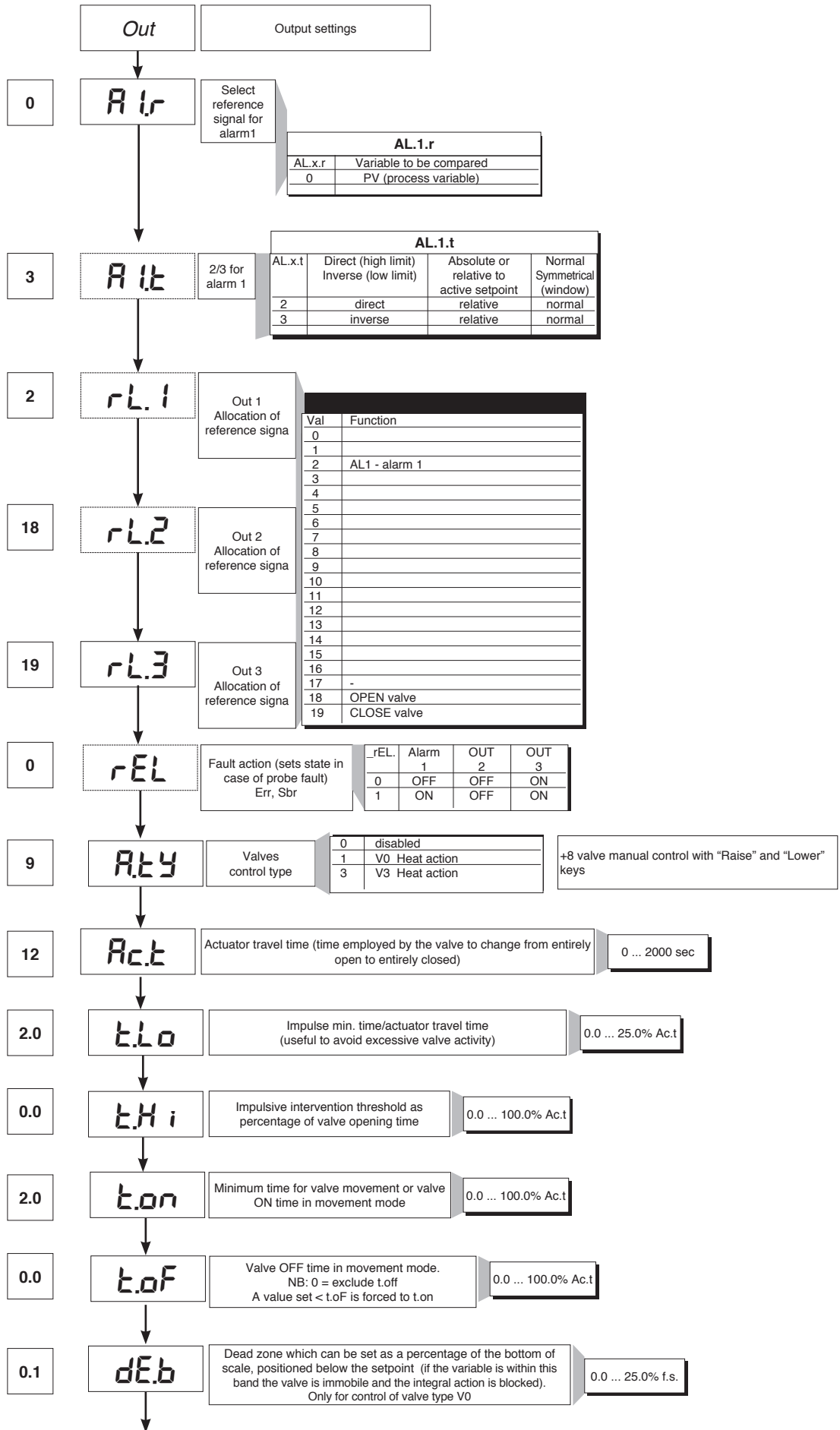

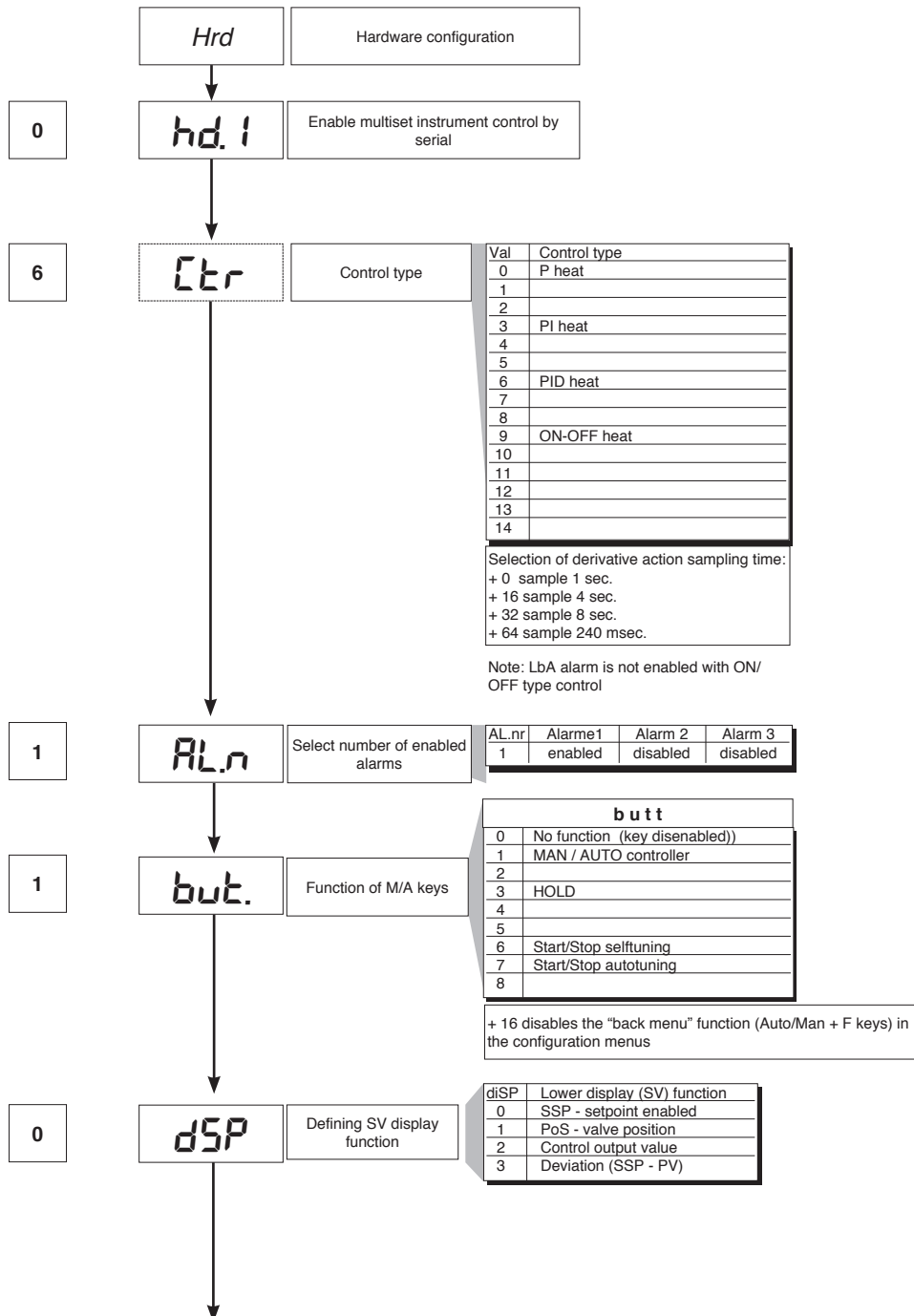
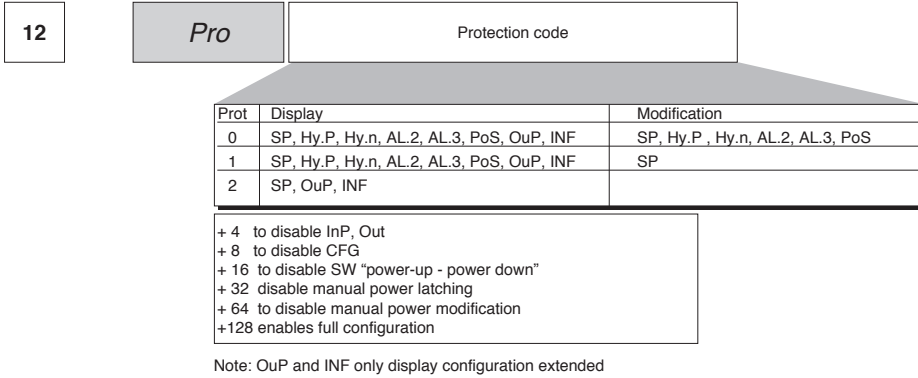

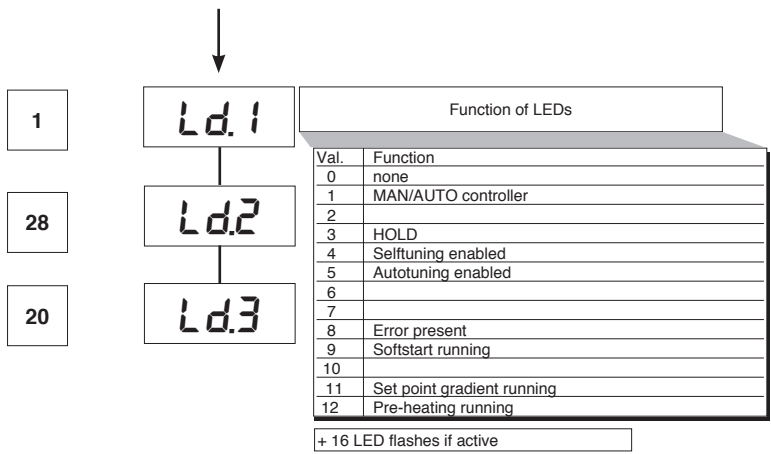

## • Lin

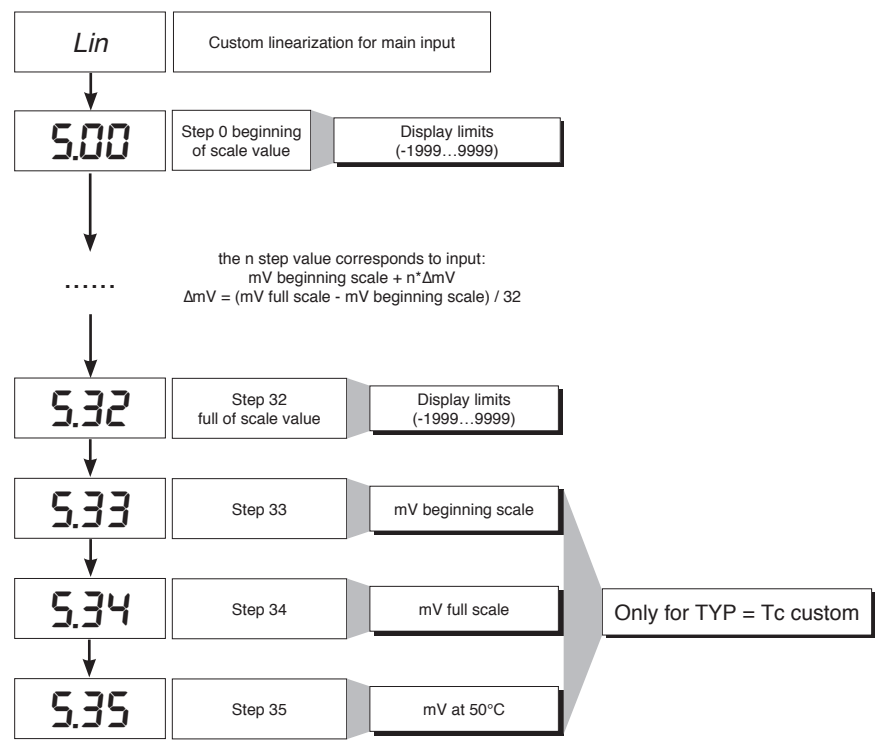

## • U.CAL

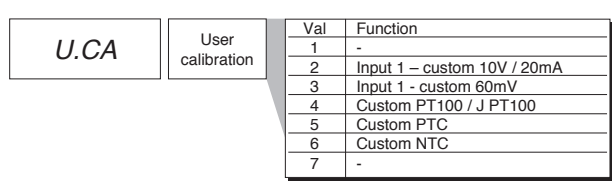

## 7 · CONSENT FOR BURNER AL1

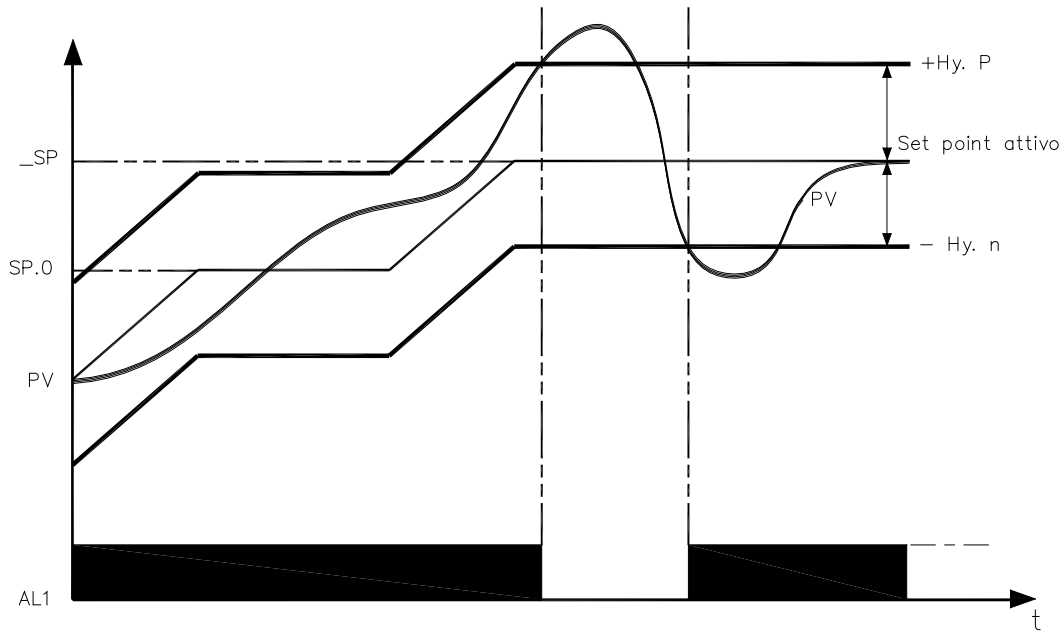

Obtain burner consent by configuring alarm 1 as inverse deviation with positive hysteresis Hy.P and negative hysteresis Hy.n

## 8 · PRE-HEATING FUNCTION

Enable the pre-heating function by setting parameters GS.0, Ht.0, GS.1 other than zero. It consists of three phases that are activated sequentially at firing:

**- Ramp 0 phase**

Enabled by setting  $GS.0 > 0$ . Starting from setpoint = PV (initial state), it reaches pre-heating set SP.0 with gradient GS.0

**- Maintenance phase**

Enabled by setting  $Ht.0 > 0$ . Maintains pre-heating setpoint SP.0 for time Ht.0

**- Ramp 1 phase**

Enabled by setting  $GS.1 > 0$ . Starting from pre-heating setpoint SP.0, it reaches active  $\_SP$  set with gradient GS.1

In case of selftuning, the pre-heating function is not activated

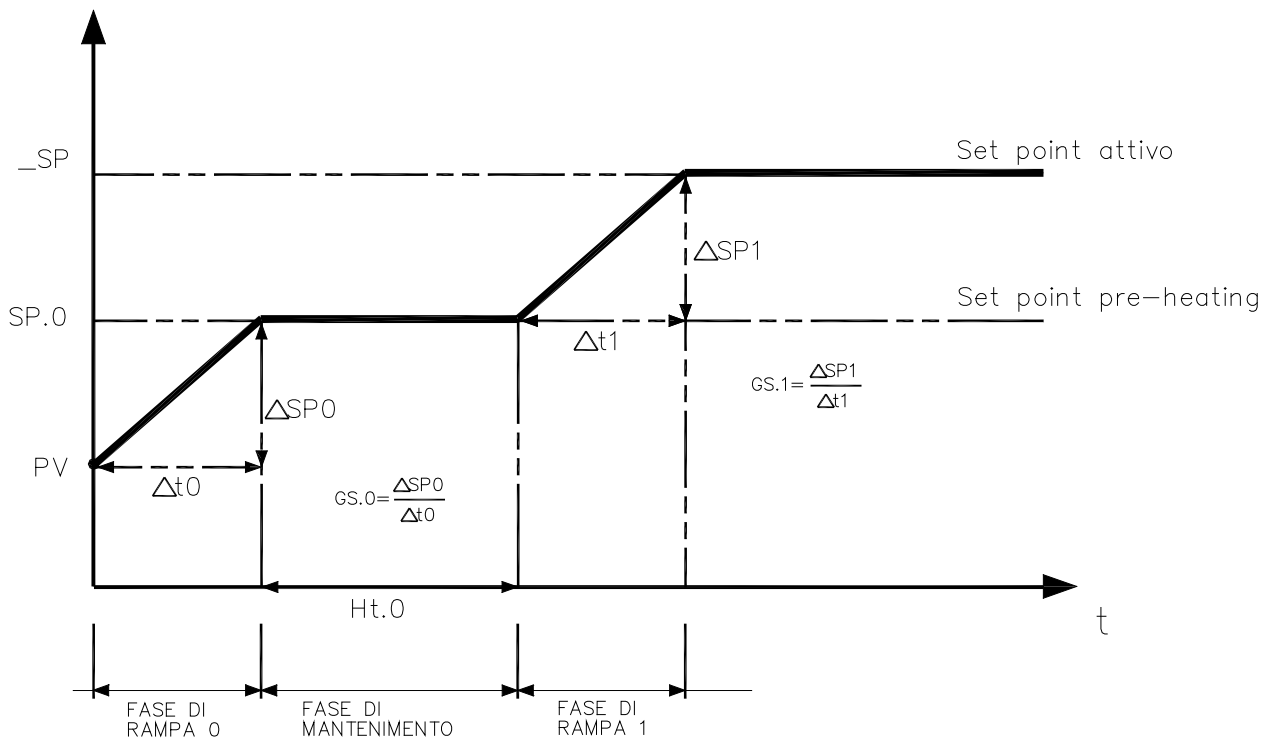

## 9 • ADJUSTMENT WITH MOTORIZED VALVE

In an adjustment process the adjustment valve has the function of varying fuel delivery (frequently corresponding to the thermal energy introduced into the process) in relation to the signal coming from the controller.

For this purpose it is provided with an actuator able to modify its opening value, overcoming the resistances produced by the fluid passing inside it.

The adjustment valves vary the delivery in a modulated manner, producing finite variations in the fluid passage inner area corresponding to finite variations of the actuator input signal, coming from the controller. The servomechanism, for example, comprises an electric motor, a reducer and a mechanical transmission system which actions the valve.

Various auxiliary components can be present such as the mechanical and electrical safety end travels, manual actioning systems.

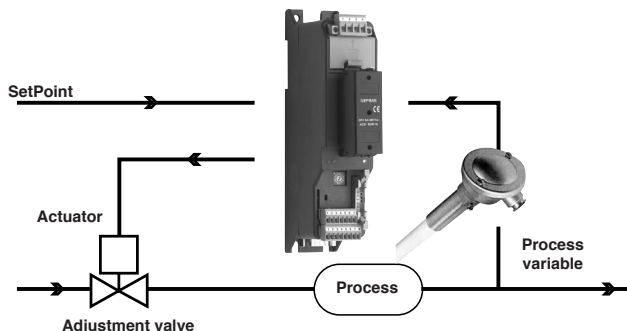

CONTROL EXAMPLE FOR V0 VALVE

The controller determines, on the basis of the dynamics of the process, the control output for the valve corresponding to the opening of the same in such a way so as to maintain the desired value of the process variable.

### Characteristic parameters for valves control

- Actuator time ( $A_c.t$ ) is the time employed by the valve to pass from entirely open to entirely closed (or vice-versa), and can be set with a resolution of one second. It is a mechanical feature of the valve+actuator unit.

**NOTE:** if the actuator's travel is mechanically limited it is necessary to proportionally reduce the  $A_c.t$  value.

- Minimum impulse ( $t.Lo$ ) expressed as a % of the actuator time (resolution 0.1%).

Represents the minimum change in position corresponding to a minimum change in power supplied by the instrument below which the actuator will not physically respond to the command.

This represents the minimum variation in position due to which the actuator does not physically respond to the command.

The minimum duration of the movement can be set in  $t.Lo$ , expressed as a % of actuator time.

- Impulsive intervention threshold ( $t.Hi$ ) expressed as a % of the actuator time (resolution 0.1%) represents the position displacement (requested position – real position) due to which the manoeuvre request becomes impulsive.

You can choose between 2 types of control:

1) ON time of movement =  $t.on$  and OFF time proportional to shift and greater than or equal to  $t.Lo$  (we recommend setting  $t.on = t.Lo$ ) (set  $t.oF = 0$ ).

2) ON time of movement =  $t.on$  and OFF time =  $t.oF$ . A value set for  $t.oF < t.on$  is forced to  $t.on$ . To activate this type, set  $t.oF >> 0$ .

The type of movement approach allows fine control of the reverse drive valve (from potentiometer or not), especially useful in cases of high mechanical inertia. Set  $t.Hi = 0$  to exclude modulation in positioning.

This type of modulated approach allows precise control of the feedback actioned valve, by a potentiometer or not, and is especially useful in cases of high mechanical inertia. Setting  $t.Hi = 0$  excludes modulation in positioning.

- Dead zone ( $dE.b$ ) is a displacement band between the adjustment setpoint and the process variable within which the controller does not supply any command to the valve (Open = OFF; Close = OFF). It is expressed as a percentage of the bottom scale and is positioned below the setpoint.

The dead zone is useful in an operative process to avoid straining the actuator with repeated commands and an insignificant effect on the adjustment. Setting  $dE.b = 0$  the dead zone is excluded.

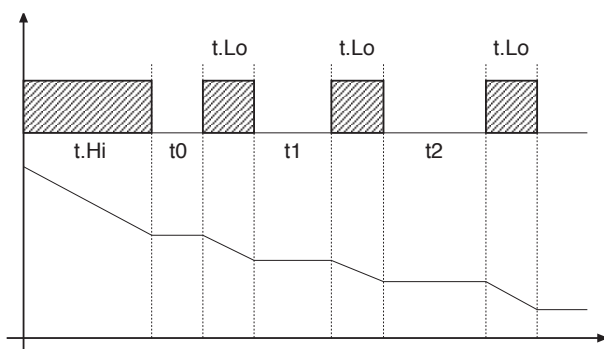

Graph of behavior inside the band with integral time  $\neq 0$ .

With integral time = 0, movement ON time is always equal to OFF time.

$t_0 = t.Lo$

## Valve control modes

With the controller in manual, the setting of parameter At.y  $\geq 8$  allows direct control of the valve open and close commands through the keyboard Increments and Decrements on the front seats.

**V0** - for floating valve without potentiometer

Model V0 have similar behaviour: every manoeuvre request greater than the minimum impulse t.Lo is sent to the actuator by means of the OPEN/CLOSE relays; every action updates the presumed position of the virtual potentiometer calculated on the basis of the actuator travel declared time.

In this way there is always a presumed position of the valve which is compared with the position request of the controller.

Having reached a presumed extreme position (entirely open or entirely closed determined by the "virtual potentiometer") the controller provides a command in the same direction, in this way ensuring the real extreme position is reached (minimum command time = t.on).

The actuators are usually protected against the OPEN command in the entirely open position or CLOSE command in the entirely closed position.

**V3** - for floating valve, PI control

When the difference between the position calculated by the controller and the only proportional component exceeds the value corresponding to the minimum impulse t.Lo the controller provides an OPEN or CLOSE command of the duration of the minimum impulse itself t.Lo.

At each delivery the integral component of the command is set to zero (discharge of the integral).

The frequency and duration of the impulses is correlated to the integral time (h.it or c.it).

*Non-movement behavior*

t.Hi = 0: with power = 100% or 0.0%, the corresponding open or close outputs always remain enabled (safety status).

*Movement behavior*

t.Hi  $\neq$  0: with position attained corresponding to 100% or 0.0%, the corresponding open or close outputs are switched off.

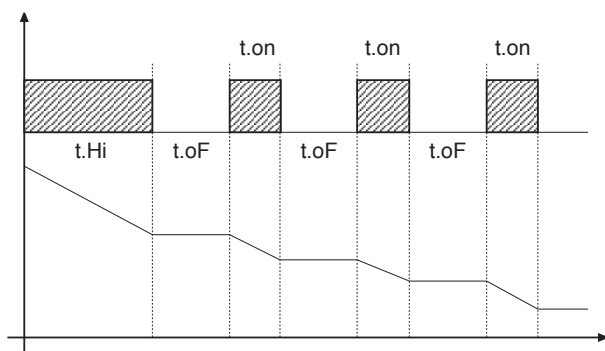

If t.oF = 0, current function is maintained.

If t.oF  $\neq$  0 movement mode will be as shown on the graph

## 10 • CONTROL ACTIONS

*Proportional Action:*

action in which contribution to output is proportional to deviation at input (deviation = difference between controlled variable and setpoint).

*Derivative Action:*

action in which contribution to output is proportional to rate of variation input deviation.

*Integral Action:*

action in which contribution to output is proportional to integral of time of input deviation.

### Influence of Proportional, Derivative and Integral actions on response of process under control

\* An increase in P.B. reduces oscillations but increases deviation.

\* A reduction in P.B. reduces the deviation but provokes oscillations of the controlled variable (the system tends to be unstable if P.B. value is too low).

\* An increase in Derivative Action corresponds to an increase in Derivative Time, reduces deviation and prevents oscillation up to a critical value of Derivative Time, beyond which deviation increases and prolonged oscillations occur.

\* An increase in Integral Action corresponds to a reduction in Integral Time, and tends to eliminate deviation between the controlled variable and the setpoint when the system is running at rated speed.

If the Integral Time value is too long (Weak integral action), deviation between the controlled variable and the setpoint may persist.

Contact GEFRA for more information on control actions.

## 11 • MANUAL TUNING

- Enter the setpoint at its working value.
- Set the proportional band at 0.1% (with on-off type setting).
- Switch to automatic and observe the behavior of the variable. It will be similar to that in the figure:

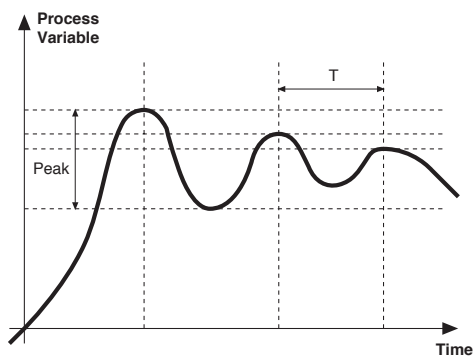

D) The PID parameters are calculated as follows: Proportional band

$$P.B. = \frac{\text{Peak}}{(V \text{ max} - V \text{ min})} \times 100$$

(V max - V min) is the scale range.

Integral time:  $I_t = 1.5 \times T$

Derivative time:  $d_t = I_t/4$

E) Switch the unit to manual, set the calculated parameters. Return to PID action by setting the appropriate relay output cycle time, and switch back to Automatic.

F) If possible, to optimize parameters, change the setpoint and check temporary response. If an oscillation persists, increase the proportional band. If the response is too slow, reduce it.

## 12 • SET GRADIENT

SET GRADIENT: if set to  $\neq 0$ , the setpoint is assumed equal to PV at power-on and auto/man switchover. With gradient set, it reaches the local setpoint. Every variation in setpoint is subject to a gradient.

The set gradient is inhibited at power-on when self-tuning is engaged.

If the set gradient is set to  $\neq 0$ , it is active even with variations of the local setpoint.

The control setpoint reaches the set value at the speed defined by the gradient.

## 13 • SOFTWARE ON / OFF SWITCHING FUNCTION

**How to switch the unit OFF:** hold down the “F” and “Raise” keys simultaneously for 5 seconds to deactivate the unit, which will go to the OFF state while keeping the line supply connected and keeping the process value displayed. The SV display is OFF.

All outputs (alarms and controls) are OFF (logic level 0, relays de-energized) and all unit functions are disabled except the switch-on function and digital communication.

**How to switch the unit ON:** hold down the “F” key for 5 seconds and the unit will switch OFF to ON. If there is a power failure during the OFF state, the unit will remain in OFF state at the next power-up (ON/OFF state is memorized).

The function is normally enabled, but can be disabled by setting the parameter Prot = Prot +16.

## 14 • SELF-TUNING

The function works for single output systems (heating or cooling). The self-tuning action calculates optimum control parameter values during process startup. The variable (for example, temperature) must be that assumed at zero power (room temperature).

The controller supplies maximum power until an intermediate value between starting value and setpoint is reached, after which it zeros power.

PID parameters are calculated by measuring overshoot and the time needed to reach peak. When calculations are finished, the system disables automatically and the control proceeds until the setpoint is reached.

**How to activate self-tuning:**

### A. Activation at power-on

- Set the setpoint to the required value
- Enable selftuning by setting the Stun parameter to 2 (CFG menu)
- Turn off the instrument
- Make sure the temperature is near room temperature
- Turn on the instrument again

### B. Activation from keyboard

- Make sure that key M/A is enabled for Start/Stop selftuning (code but = 6 Hrd menu)
- Bring the temperature near room temperature
- Set the setpoint to the required value
- Press key M/A to activate selftuning (Attention: selftuning interrupts if the key is pressed again)

The procedure runs automatically until finished, when the new PID parameters are stored: proportional band, integral and derivative times calculated for the active action (heating or cooling). In case of double action (heating or cooling), parameters for the opposite action are calculated by maintaining the initial ratio between parameters (ex.:  $CPb = HPb \times K$ ; where  $K = CPb / HPb$  when self-tuning starts). When finished, the Stun code is automatically cancelled.

### Notes :

-The procedure does not start if the temperature is higher than the setpoint (heating control mode) or if the temperature is lower than the setpoint (cooling control mode). In this case, the Stun code is not cancelled.

-It is advisable to enable one of the configurable LEDs to signal selftuning status. By setting one of parameters LED1, LED2, LED3=4 or 20 on the Hrd menu, the respective LED will be on or flashing when selftuning is active.

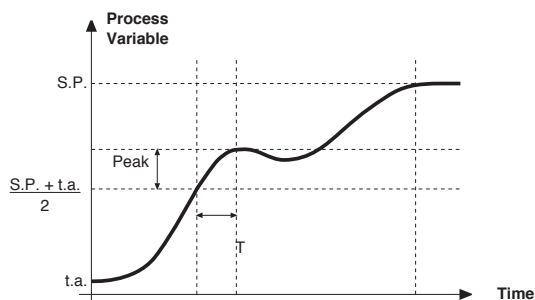

## 15 • ACCESSORIES

### • Interface for instrument configuration



Kit for PC via the USB port (Windows environment) for GEFRAN instruments configuration:

Lets you read or write all of the parameters

- A single software for all models
- Easy and rapid configuration
- Saving and management of parameter recipes
- On-line trend and saving of historical data

Component Kit:

- Connection cable PC USB ... port TTL
- Connection cable PC USB ... RS485 port
- Serial line converter
- CD SW GF Express installation

### • ORDERING CODE

GF_eXK-2-0-0	cod F049095
--------------	-------------

## 16 • ORDER CODE

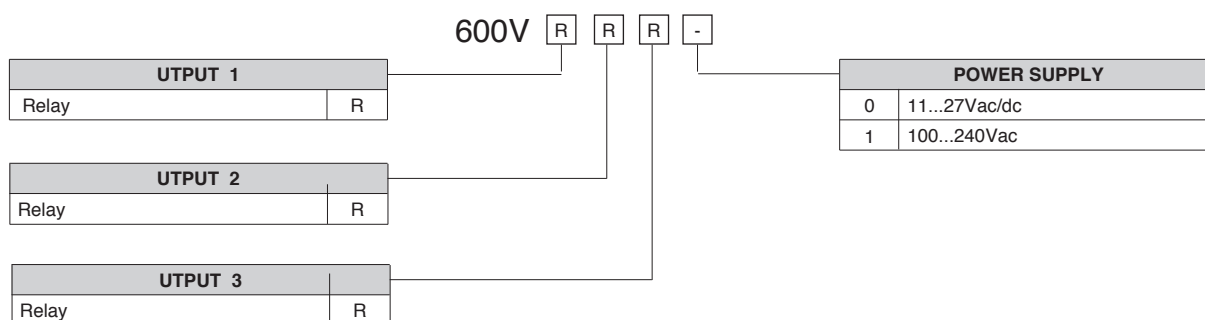

## • WARNINGS

**WARNING:** this symbol indicates danger. It is placed near the power supply circuit and near high-voltage relay contacts.

**Read the following warnings before installing, connecting or using the device:**

- follow instructions precisely when connecting the device.
- always use cables that are suitable for the voltage and current levels indicated in the technical specifications.
- the device has no ON/OFF switch: it switches on immediately when power is turned on. For safety reasons, devices permanently connected to the power supply require a two-phase disconnecting switch with proper marking. Such switch must be located near the device and must be easily reachable by the user. A single switch can control several units.
- if the device is connected to electrically NON-ISOLATED equipment (e.g. thermocouples), a grounding wire must be applied to assure that this connection is not made directly through the machine structure.
- if the device is used in applications where there is risk of injury to persons and/or damage to machines or materials, it MUST be used with auxiliary alarm units. You should be able to check the correct operation of such units during normal operation of the device.
- before using the device, the user must check that all device parameters are correctly set in order to avoid injury to persons and/or damage to property.
- the device must NOT be used in inflammable or explosive environments. It may be connected to units operating in such environments only by means of suitable interfaces in conformity to local safety regulations.
- the device contains components that are sensitive to static electrical discharges. Therefore, take appropriate precautions when handling electronic circuit boards in order to prevent permanent damage to these components.

**Installation:** installation category II, pollution level 2, double isolation

The equipment is intended for permanent indoor installations within their own enclosure or panel mounted enclosing the rear housing and exposed terminals on the back.

- only for low power supply: supply from Class 2 or low voltage limited energy source
- power supply lines must be separated from device input and output lines; always check that the supply voltage matches the voltage indicated on the device label.
- install the instrumentation separately from the relays and power switching devices
- do not install high-power remote switches, contactors, relays, thyristor power units (particularly if "phase angle" type), motors, etc... in the same cabinet.
- avoid dust, humidity, corrosive gases and heat sources.
- do not close the ventilation holes; working temperature must be in the range of 0...50°C.

- surrounding air: 50°C
- use 60/75°C copper (Cu) conductor only, wire size range 2x No 22 - 14AWG, Solid/Stranded
- use terminal tightening torque 0.5N m

If the device has faston terminals, they must be protected and isolated; if the device has screw terminals, wires should be attached at least in pairs.

• **Power:** supplied from a disconnecting switch with fuse for the device section; path of wires from switch to devices should be as straight as possible; the same supply should not be used to power relays, contactors, solenoid valves, etc.; if the voltage waveform is strongly distorted by thyristor switching units or by electric motors, it is recommended that an isolation transformer be used only for the devices, connecting the screen to ground; it is important for the electrical system to have a good ground connection; voltage between neutral and ground must not exceed 1V and resistance must be less than 60hm; if the supply voltage is highly variable, use a voltage stabilizer for the device; use line filters in the vicinity of high frequency generators or arc welders; power supply lines must be separated from device input and output lines; always check that the supply voltage matches the voltage indicated on the device label.

• **Input and output connections:** external connected circuits must have double insulation; to connect analog inputs (TC, RTD) you have to: physically separate input wiring from power supply wiring, from output wiring, and from power connections; use twisted and screened cables, with screen connected to ground at only one point; to connect adjustment and alarm outputs (contactors, solenoid valves, motors, fans, etc.), install RC groups (resistor and capacitor in series) in parallel with inductive loads that work in AC (*Note: all capacitors must conform to VDE standards (class x2) and support at least 220 VAC. Resistors must be at least 2W*); fit a 1N4007 diode in parallel with the coil of inductive loads that operate in DC.

**GEFRAN spa will not be held liable for any injury to persons and/or damage to property deriving from tampering, from any incorrect or erroneous use, or from any use not conforming to the device specifications.**



## Set-up for 600V RRR0-1-T73 regulator

### Set up for temperature probe Pt100 (ex Siemens QAE2120 130°C max.)

The regulator comes out of the factory preset with the corresponding values of the Siemens RWF40.000 and RWF50.2x

Verify wiring of the sensor

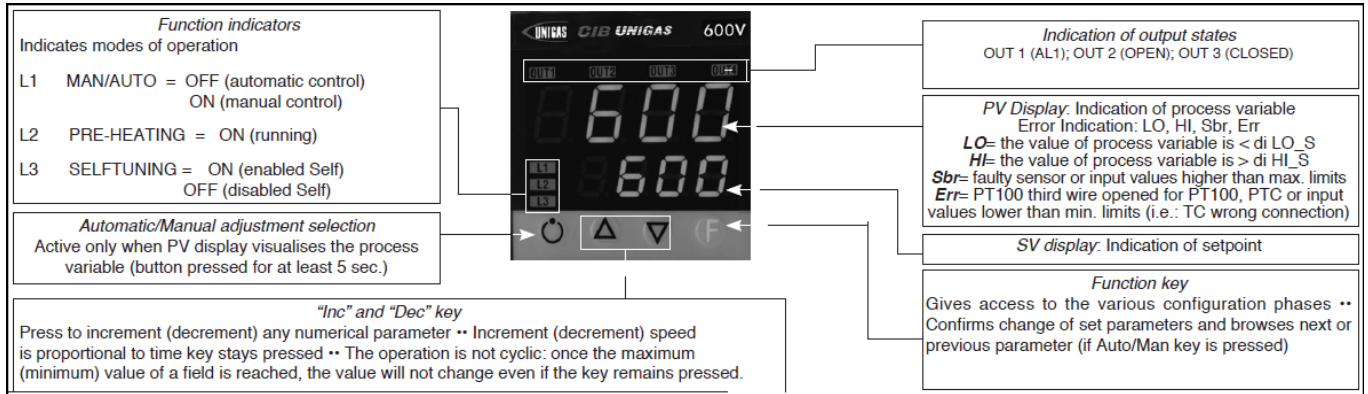

Regulation of the set-point = 80

It can be modified by using arrows "up" and "down".

By pushing F you go to parameters:

Hy.P	5 (hysteresis positive for output 1, terminals 21-22 (ex Q13-Q14))
Hy.n	-5 hysteresis negative for output ,1 terminals 21-22 (ex Q13-Q14)

Keep pushing F until you see **PASS**, release F and through the arrows set **99**, push F and visualize **Pro** (protection code) default is **12**, through the arrows set **128** and push F, keep it pushed until all parameters **InF**, **CFG**, **InP**, **Out**, **PASS** are visualized.

CFG	
S.tun	0
hPb	1,2
hIt	5,83
hdt	1,33
...	

InP	
....	
tyP	30 (Pt100)
...	
dP_S	1 (decimals num.)
Lo.S	0 (min. sensor scale)
Hi.S	850,0 (max sensor scale)
oFS	0 (offset of input correction)
Lo.L	30,0 (lower set-point range limit)
Hi.L	130,0 (upper set-point range limit)

<b>Out</b>	
A1.r	0
...	
A1.t	3 (operating mode AL1 =inverse-relative-normal)
...	
rL.1	2 (AL1)
rL.2	18 (open)
rL.3	19 (close)
rEL	0
A.ty	9 (type of servocontrol command)
Ac.t	12 (servocontrol running time: SQN72.4.../STA12..=12; SQM40.265=30)
t Lo	2
t Hi	0.0
t.on	2
t.oF	0.0
dE.b	0,1 (dead zone in % of end scale)

<b>PAS</b>	99 then push and keep pushed <b>F</b> until visualization of <b>Hrd</b>
<b>Hrd</b>	
...	
Ctrl	6 (PID warm)
AL.nr	1
but	1
diSP	0
Ld.1	1
Ld.2	28
Ld.3	20

Keep pushed **F** until you visualize **PASS**, release **F** and through the arrows set **99**, push **F** and visualize **Pro** (protection code) from **128**, through the arrows, bring it back to **12**, and keep **F** pushed until you come back to set-point value.

#### **Manual operation :**

Keep pushed the lower left key for at least 5 sec.

The instrument will enter the "MAN" mode (see also "Ld1" switching on).

Through the arrows, "Open" and "Close" outputs are activated.

To come back to normal working keep the lower left key pushed for at least 5 sec.

#### **Software switch off :**

By keeping pushed keys **Arrow up** + **F** for more than 5 sec. the instrument switches off the software, does not command the outputs and visualize only the variable of process measured by the probe.

To restore keep pushed **F** for more than 5 sec.

**Set up for temperature probe Pt100 for high temperature (350°C max.)**

Verify wiring of the sensor

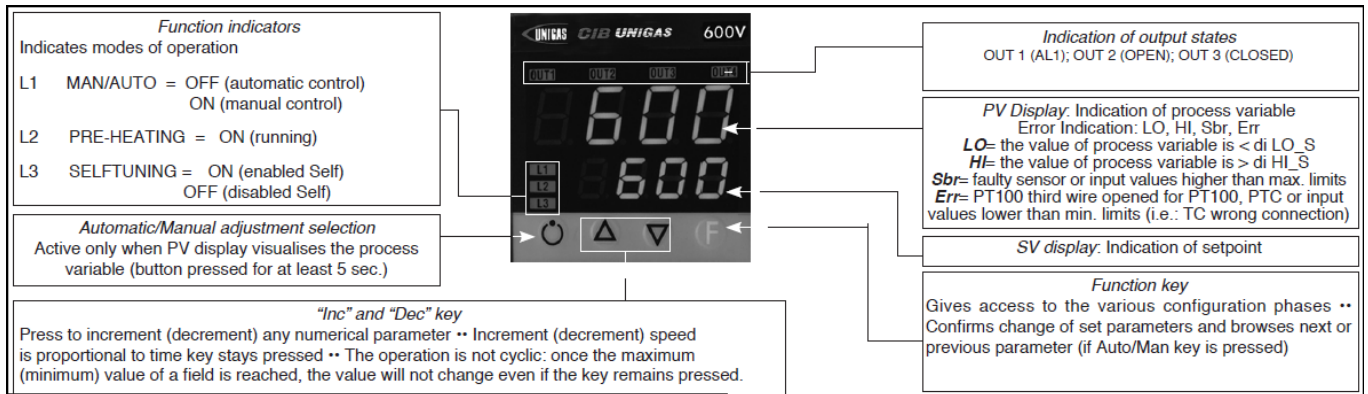

Regulation of the set-point = **80**

It can be modified by using arrows "up" and "down".

By pushing **F** you go to parameters:

Hy.P	10 (hysteresis positive for output 1 terminals 21-22 (ex Q13-Q14))
Hy.n	-5 (hysteresis negative for output 1 terminals 21-22 (ex Q13-Q14))

Keep pushing **F** until you see **PASS**, release **F** and through the arrows set **99**, push **F** and visualize **Pro** (protection code) default is **12**, through the arrows set **128** and push **F**, keep it pushed until all parameters **InF**, **CFG**, **InP**, **Out**, **PASS** are visualized.

CFG	
S.tun	0
hPb	1,2
hIt	5,83
hdt	1,33
...	

InP	
....	
tyP	30 (Pt100)
...	
dP_S	1 (decimals num.)
Lo.S	0 (min. sensor scale)
Hi.S	850,0 (max sensor scale)
oFS	0 (offset of input correction)
Lo.L	0,0 (lower set-point range limit)
Hi.L	350,0 (upper set-point range limit)

<b>Out</b>	
A1.r	0
...	
A1.t	3 (mode AL1 =inverse-relative-normal)
...	
rL.1	2 (AL1)
rL.2	18 (open)
rL.3	19 (close)
rEL	0
A.ty	9 (type of servocontrol command)
Ac.t	12 (servocontrol running time: SQN72.4.../STA12..=12; SQM40.265=30)
t Lo	2
t Hi	0.0
t.on	2
t.oF	0.0
dE.b	0,1 (dead zone in % of end scale)

<b>PAS</b>	99 then push and keep pushed <b>F</b> until visualization of <b>Hrd</b>
<b>Hrd</b>	
...	
Ctrl	6 (PID warm)
AL.nr	1
but	1
diSP	0
Ld.1	1
Ld.2	28
Ld.3	20

Keep pushed **F** until you visualize **PASS**, release **F** and through the arrows set **99**, push **F** and visualize **Pro** (protection code) from **128**, through the arrows, bring it back to **12**, and keep **F** pushed until you come back to set-point value.

#### **Manual operation:**

Keep pushed the lower left key for at least 5 sec.

The instrument will enter the "MAN" mode (see also "Ld1" switching on).

Through the arrows, "Open" and "Close" outputs are activated.

To come back to normal working keep the lower left key pushed for at least 5 sec.

#### **Software switch off :**

By keeping pushed keys **Arrow up** + **F** for more than 5 sec. the instrument switches off the software, does not command the outputs and visualize only the variable of process measured by the probe.

To restore keep pushed **F** for more than 5 sec.

## Set up for pressure transmitter 2 wires signal 4÷20mA

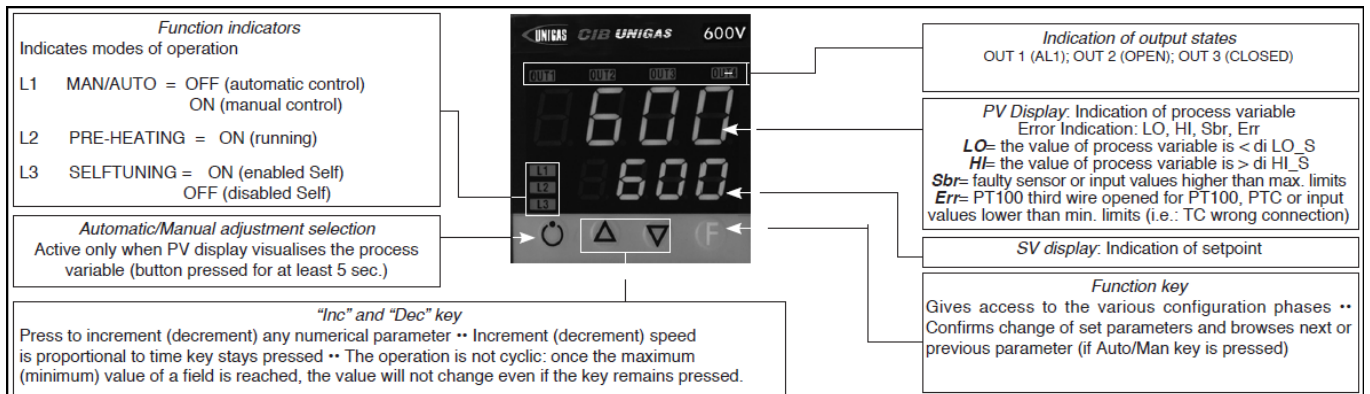

With pressure transmitters first we need to enable their power supply: remove the part as shown below, then, on the CPU unit, move the bridge from Pt100 to +Vt

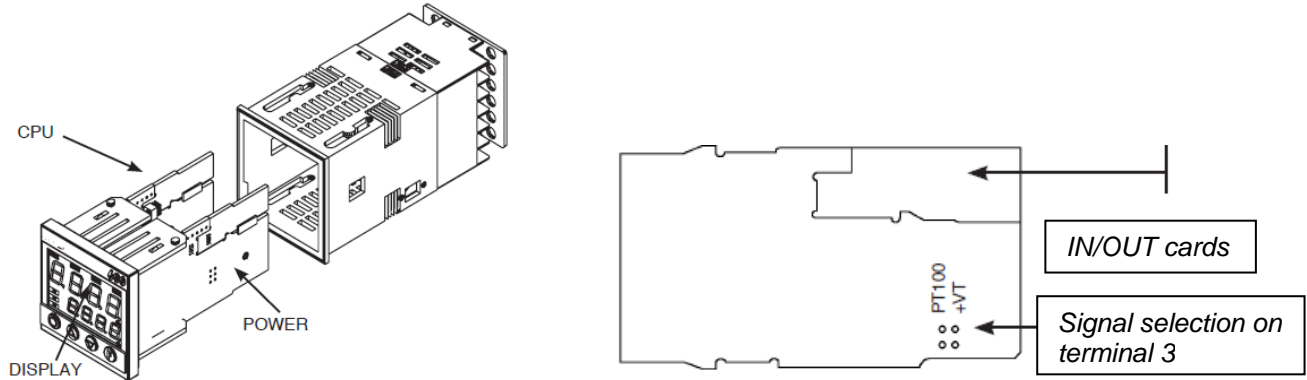

Verify wiring of the sensor

Impostazione set-point

Transmitter	1,6bar	3bar	10bar	16bar	25bar	40bar
Set-point	1bar	1,5bar	6bar	6bar	6bar	6bar

To modify it directly use "up" and "down" arrows.

By pushing **F** you go to parameter:

Transmitter	1,6bar	3bar	10bar	16bar	25bar	40bar
Hy.P	0,2bar	0,5bar	0,5bar	0,8bar	1,25bar	2bar
Hy.n	0bar	0bar	0bar	0bar	0bar	0bar

Keep pushing **F** until you see **PASS**, release **F** and through the arrows set **99**, push **F** and visualize **Pro** (protection code) default is **12**, through the arrows set **128** and push **F**, keep it pushed until all parameters **InF**, **CFG**, **InP**, **Out**, **PASS** are visualized.

CFG	
S.tun	0
hPb	5
hIt	1,33
hdt	0,33
...	

InP	
....	
tyP	44 (4÷20mA)
...	
dP_S	2 (decimals num.)

Transmitter	1,6bar	3bar	10bar	16bar	25bar	40bar	
Lo.S	0,00	0,00	0,00	0,00	0,00	0,00	min. sensor scale
Hi.S	1,60	3,00	10,00	16,00	25,00	40,00	max sensor scale
oFS	0	0	0	0	0	0	offset of input correction
Lo.L	0,00	0,00	0,00	0,00	0,00	0,00	lower set-point setting
Hi.L	1,60	3,00	10,00	16,00	25,00	40,00	upper set-point setting

Out	
A1.r	0
...	
A1.t	3 (mode AL1 =inverse-relative-normal)
...	
rL.1	2 (AL1)
rL.2	18 (open)
rL.3	19 (close)
rEL	0
A.ty	9 (type of servocontrol command)
Ac.t	12 (servocontrol running time: SQN72.4.../STA12..=12; SQM40.265=30)
t Lo	2
t Hi	0.0
t.on	2
t.oF	0.0
dE.b	0,1 (dead zone in % of end scale)

PAS	
	99 then push and keep pushed <b>F</b> until visualization of <b>Hrd</b>
Hrd	
...	
Ctrl	6 (PID warm)
AL.nr	1
but	1
diSP	0
Ld.1	1
Ld.2	28
Ld.3	20

Keep pushed **F** until you visualize **PASS**, release **F** and through the arrows set **99**, push **F** and visualize **Pro** (protection code) from **128**, through the arrows, bring it back to **12**, and keep **F** pushed until you come back to set-point value.

#### Manual operation:

Keep pushed the lower left key for at least 5 sec.

The instrument will enter the "MAN" mode (see also "Ld1" switching on).

Through the arrows, "Open" and "Close" outputs are activated.

To come back to normal working keep the lower left key pushed for at least 5 sec.

#### Software switch off :

By keeping pushed keys **Arrow up** + **F** for more than 5 sec. the instrument switches off the software, does not command the outputs and visualize only the variable of process measured by the probe.

To restore keep pushed **F** for more than 5 sec.

## Set-up for thermocouples type **K** or **J**

Verify wiring of the sensor

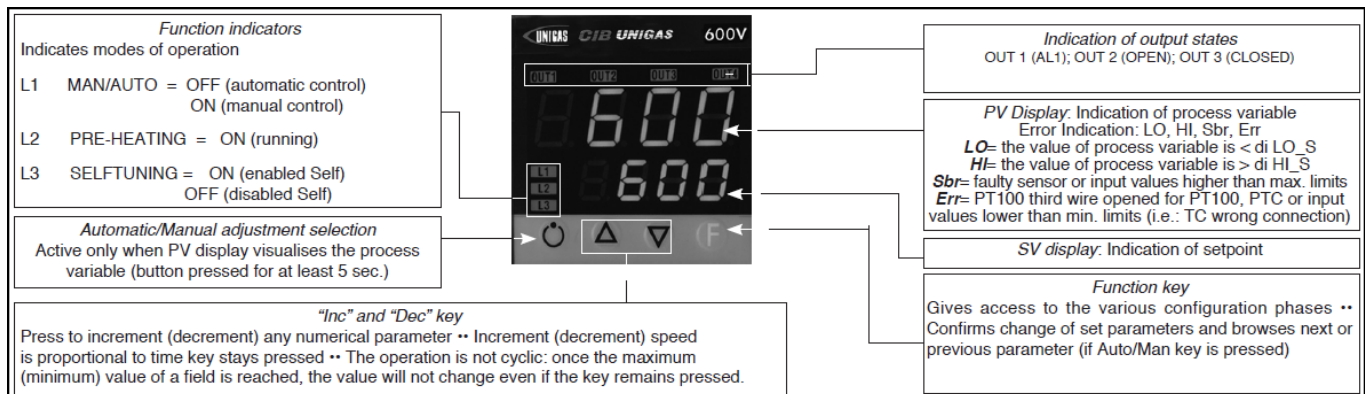

Regulation of the set-point = **80**

It can be modified by using arrows "up" and "down".

By pushing **F** you go to parameters:

Hy.P	10 (hysteresis positive for output 1 terminals 21-22 (ex Q13-Q14))
Hy.n	-5 (hysteresis negative for output 1 terminals 21-22 (ex Q13-Q14))

Keep pushing **F** until you see **PASS**, release **F** and through the arrows set **99**, push **F** and visualize **Pro** (protection code) default is **12**, through the arrows set **128** and push **F**, keep it pushed until all parameters **InF**, **CFG**, **InP**, **Out**, **PASS** are visualized.

<b>CFG</b>	
S.tun	0
hPb	1,2
hIt	5,83
hdt	1,33
...	

<b>InP</b>	
....	
tyP	2 (thermocouple <b>K</b> 0÷1300°C) / 0 (thermocouple <b>J</b> 0÷1000°C)
...	
dP_S	0 (no decimal) / 1 (1 decimal)
Lo.S	0 (min. sensor scale)
Hi.S	1300 (max sensor scale for tc <b>K</b> ) / 1000 (max sensor scale for tc <b>J</b> )
oFS	0 (offset of input correction)
Lo.L	0 (lower set-point range limit)
Hi.L	1300 (upper set-point range limit) per tc <b>K</b> / 1000 for tc <b>J</b>

<b>Out</b>	
A1.r	0
...	
A1.t	3 (mode AL1 =inverse-relative-normal)
...	
rL.1	2 (AL1)
rL.2	18 (open)
rL.3	19 (close)
rEL	0
A.ty	9 (type of servocontrol command)
Ac.t	12 (servocontrol running time: SQN72.4.../STA12..=12; SQM40.265=30)
t Lo	2
t Hi	0.0
t.on	2
t.oF	0.0
dE.b	0,1 (dead zone in % of end scale)

<b>PAS</b>	99 then push and keep pushed <b>F</b> until visualization of <b>Hrd</b>
...	
<b>Hrd</b>	
...	
Ctrl	6 (PID warm)
AL.nr	1
but	1
diSP	0
Ld.1	1
Ld.2	28
Ld.3	20

Keep pushed **F** until you visualize **PASS**, release **F** and through the arrows set **99**, push **F** and visualize **Pro** (protection code) from **128**, through the arrows, bring it back to **12**, and keep **F** pushed until you come back to set-point value.

#### Manual operation:

Keep pushed the lower left key for at least 5 sec.

The instrument will enter the "MAN" mode (see also "Ld1" switching on).

Through the arrows, "Open" and "Close" outputs are activated.

To come back to normal working keep the lower left key pushed for at least 5 sec.

#### Software switch off :

By keeping pushed keys **Arrow up** + **F** for more than 5 sec. the instrument switches off the software, does not command the outputs and visualize only the variable of process measured by the probe.

To restore keep pushed **F** for more than 5 sec.





# VERSIONE MONOSTADIO "TN" "TN" SINGLE-STAGE VERSION

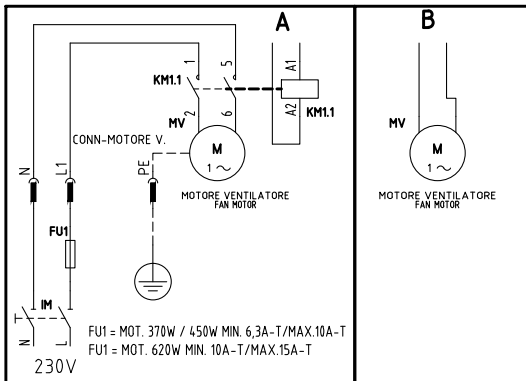
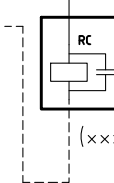
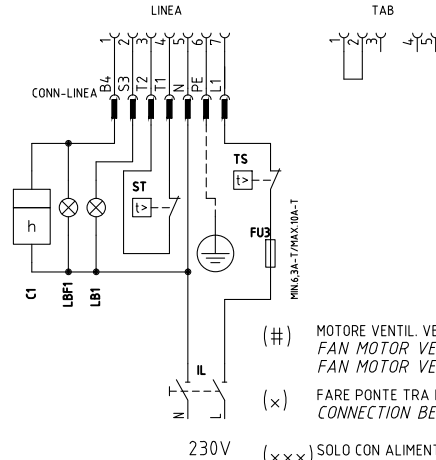
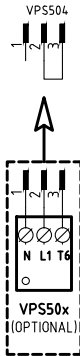
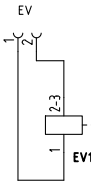
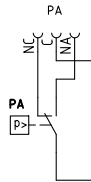
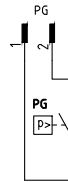
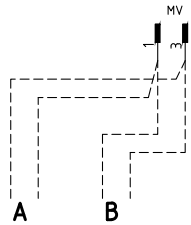
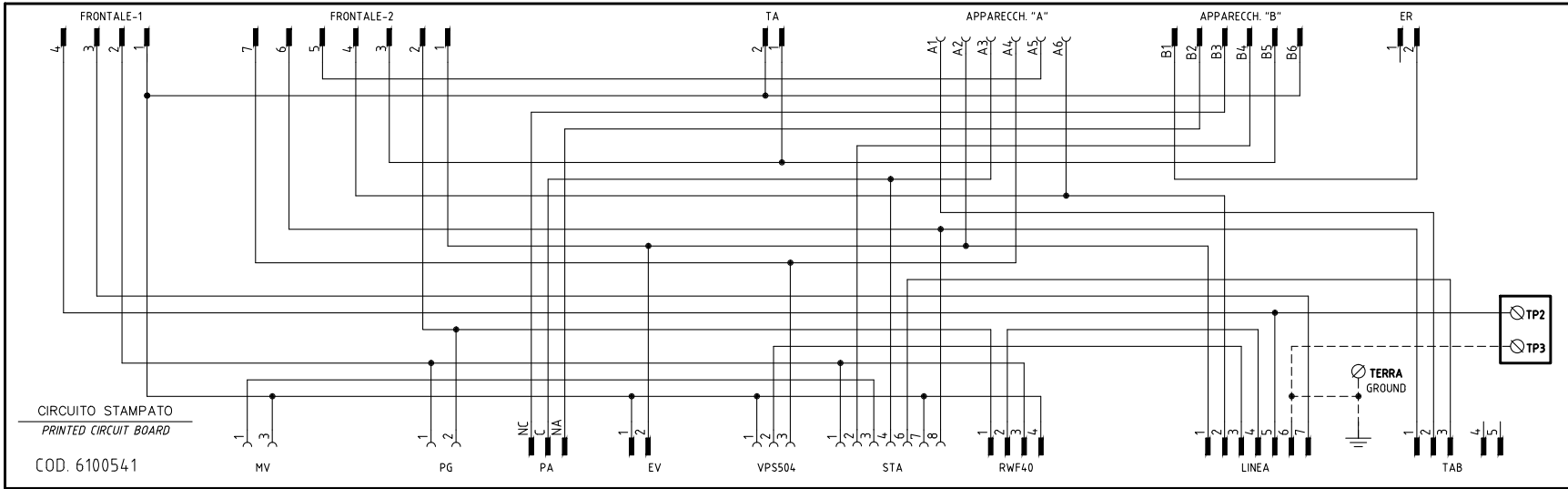
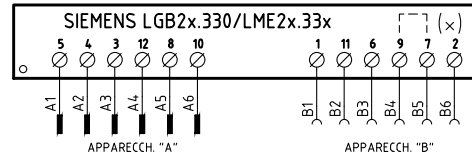
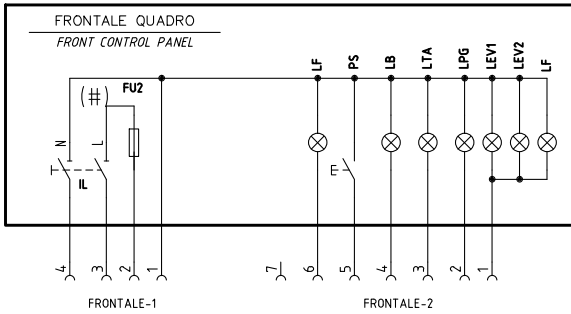

- (#) MOTORE VENTIL. VERSIONE [A], FU2 = 6,3A F; MOTORE VENTIL. VERSIONE [B], FU2 = 10A F  
FAN MOTOR VERSION [A], FU2= 6,3 A F;  
FAN MOTOR VERSION [B], FU2= 10 A F
- (x) FARE PONTE TRA I MORSETTI 7 E 9 SOLO CON LGB21.330  
CONNECTION BETWEEN TERMINALS 7 AND 9 WITH LGB21.330 ONLY
- (x x x) SOLO CON ALIMENTAZIONE ELETTRICA SENZA NEUTRO  
WITH ELECTRIC SUPPLY WITHOUT NEUTRAL VERSION ONLY

REV.	MODIFICA	DATA	FIRME
05	AGGIUNTO/ADDED "KVB" ASCON	07/08/14	U. PINTON
04	AGGIUNTO/ADDED "600V"	19/06/12	U. PINTON
03	AGGIUNTO/ADDED "RWF502x"	20/01/12	U. PINTON
02	MOTOR MODIFY	19/10/10	U. PINTON
01	AGGIUNTO / ADDED SGM72...	22/05/09	U. PINTON

	Impianto <b>TIPI/TYPES NG(X)350/400/550 - LG(X)350/400/550</b> <b>MODELLI/MODELS x-.TN(PR)(MD).x.xx.A.x.xx</b>	Ordine	Data	19/10/2010	PREC.	FOGLIO
	Descrizione <b>VERSIONE CON CIRCUITO STAMPATO</b> <b>WITH PRINTED CIRCUIT VERSION</b>	Commessa	Data Controllato	07/08/2014	Revisione	05
	Esecutore	U. PINTON	Controllato	E. CAVALLI	Dis. N.	18 - 0163
					SEQUE	TOTALE
					2	5

VERSIONE ALTA-BASSA FIAMMA "AB" / PROGRESSIVO "PR"  
 "AB" HIGH-LOW / "PR" PROGRESSIVE VERSION

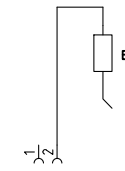
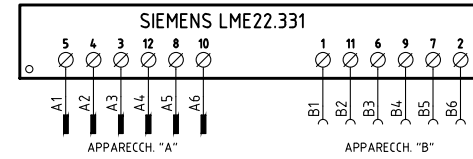
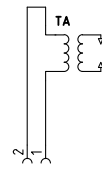
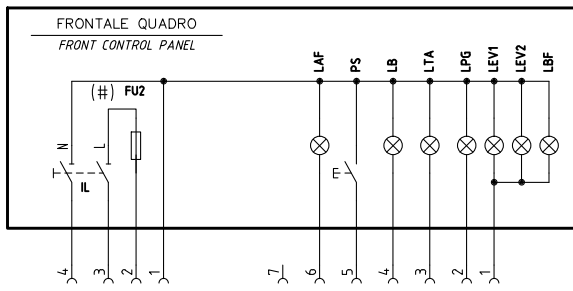

SERVOCOMANDO SERRANDA ARIA  
 AIR DAMPER ACTUATOR  
 STA13B0.36/83N30L

I ALTA FIAMMA  
 HIGH FLAME  
 II SOSTA  
 STAND-BY  
 III BASSA FIAMMA  
 LOW FLAME  
 IV (NERO)  
 NON USATA  
 NOT USED

SERVOCOMANDO SERRANDA ARIA  
 AIR DAMPER ACTUATOR  
 SIEMENS SQNT2.xA4.A20

I (ROSSO) ALTA FIAMMA  
 HIGH FLAME  
 II (BLU) SOSTA  
 STAND-BY  
 III (ARANCIO) BASSA FIAMMA  
 LOW FLAME  
 IV (NERO)  
 NON USATA  
 NOT USED

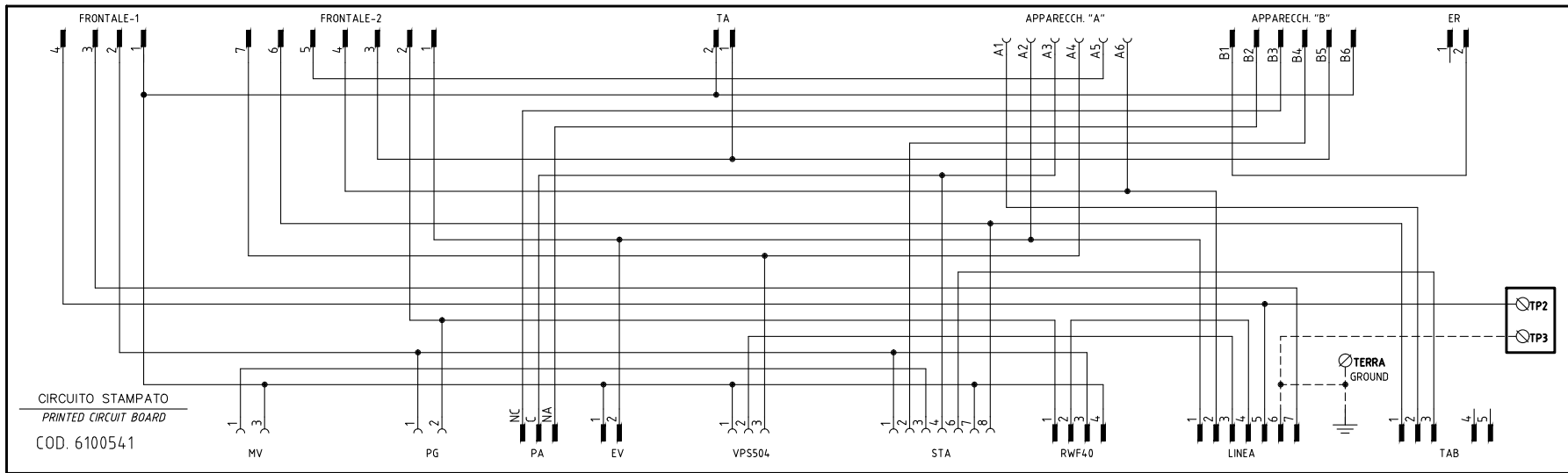

COD. 6100541

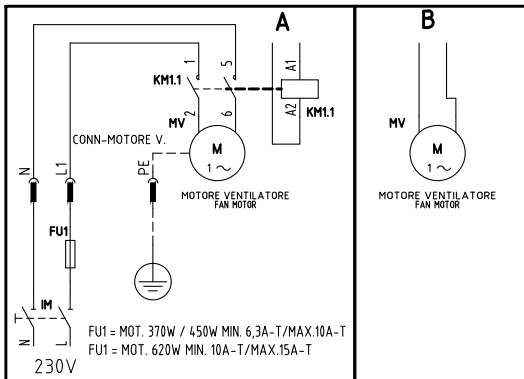
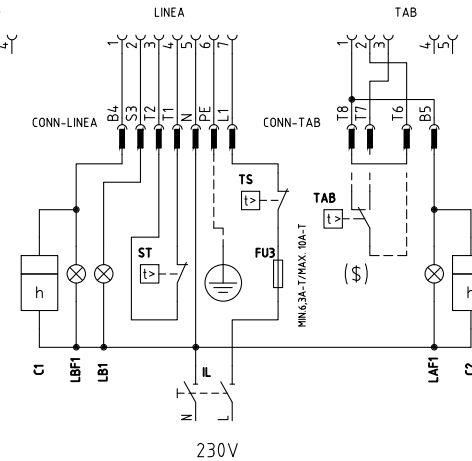
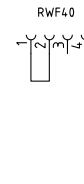
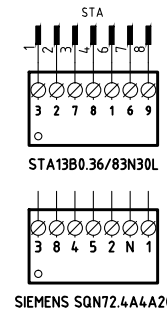
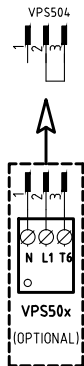
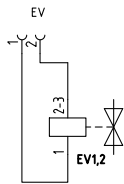
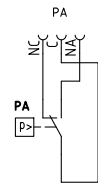
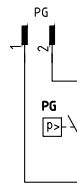
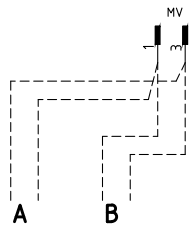

(#) MOTORE VENTIL. VERSIONE [A], FU2 = 6,3A F; MOTORE VENTIL. VERSIONE [B], FU2 = 10A F  
 FAN MOTOR VERSION [A], FU2 = 6,3 A F;  
 FAN MOTOR VERSION [B], FU2 = 10 A F

(x x x) SOLO CON ALIMENTAZIONE ELETTRICA SENZA NEUTRO  
 WITH ELECTRIC SUPPLY WITHOUT NEUTRAL VERSION ONLY

(\$) SE USATO "TAB", TOGLIERE IL PONTE TRA I MORSETTI T6-T8  
 IF USED "TAB", REMOVE THE BRIDGE BETWEEN TERMINALS T6-T8

Data	19/10/2010	PREC.	FOGLIO
Revisione	05	1	2
Dis. N.	18 - 0163	SEGUE	TOTALE
		3	5

VERSIONE MODULANTE "MD"  
"MD" MODULATING VERSION

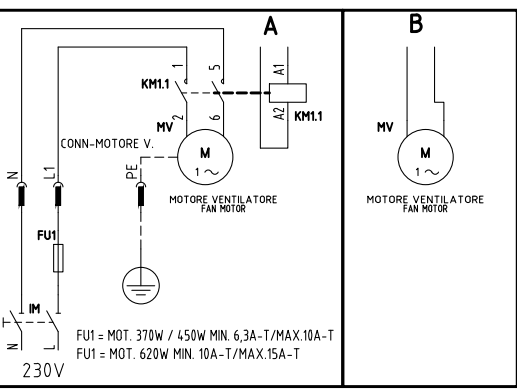
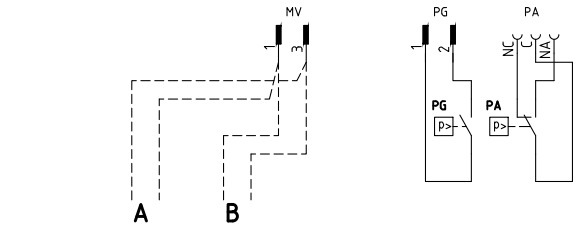
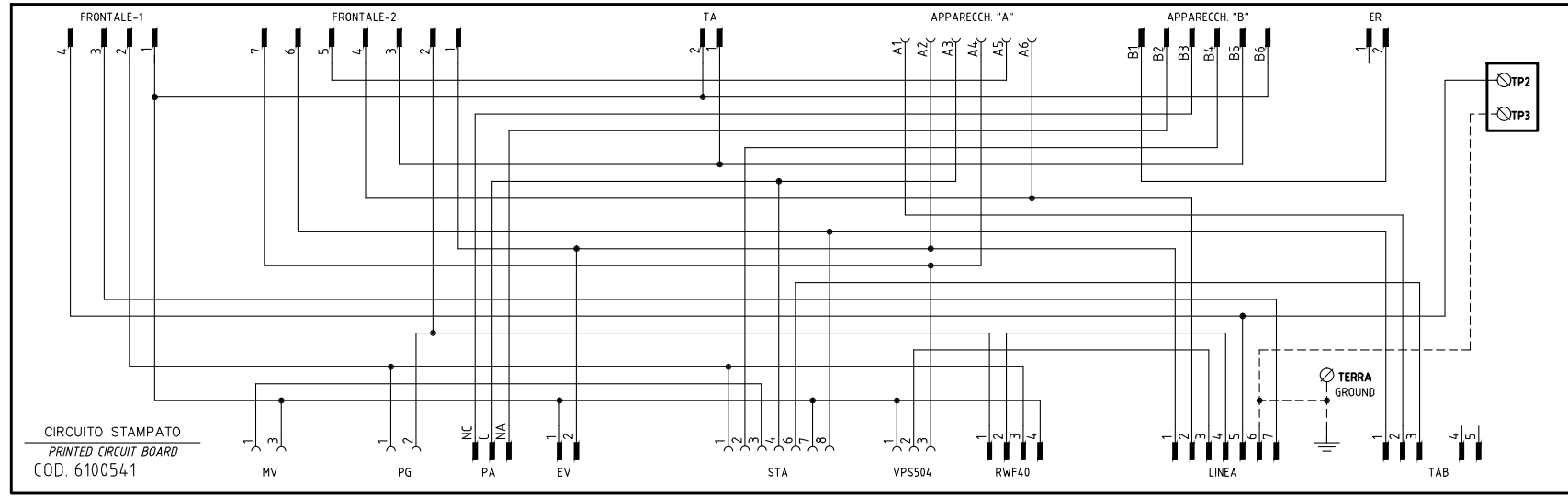
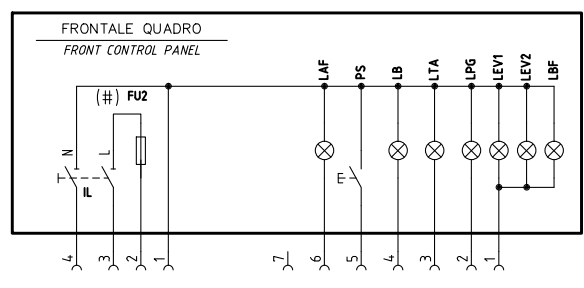

SERVOCOMANDO SERRANDA ARIA  
AIR DAMPER ACTUATOR  
STA13B0.36/83N30L

I ALTA FIAMMA HIGH FLAME  
II SOSTA STAND-BY  
III BASSA FIAMMA LOW FLAME  
IV NON USATA NOT USED

SERVOCOMANDO SERRANDA ARIA  
AIR DAMPER ACTUATOR  
SIEMENS SQN72.xA4.A20

I (ROSSO) ALTA FIAMMA HIGH FLAME  
II (BLU) SOSTA STAND-BY  
III (ARANCIO) BASSA FIAMMA LOW FLAME  
IV (NERO) NON USATA NOT USED

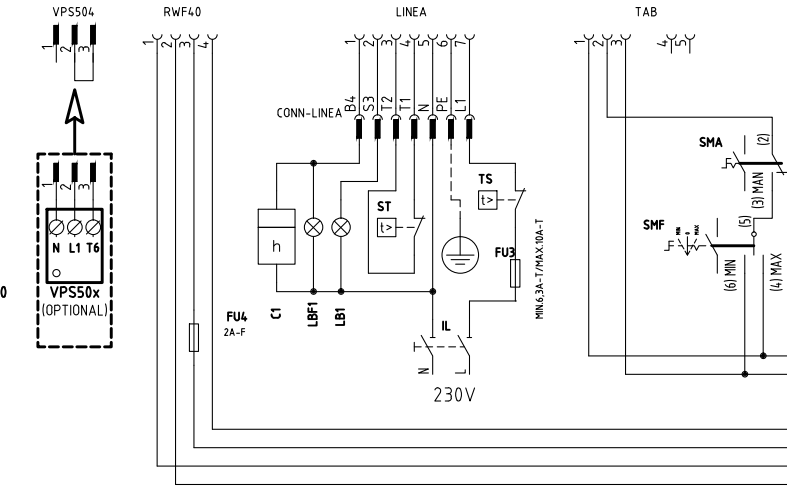
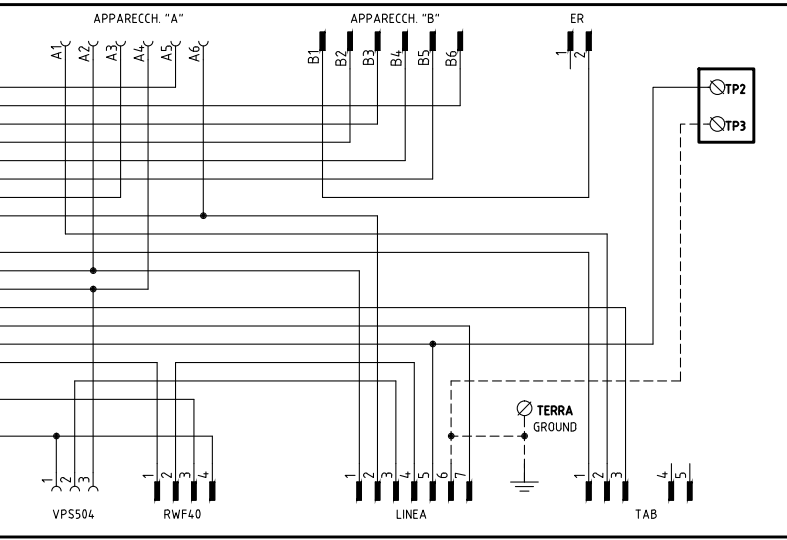
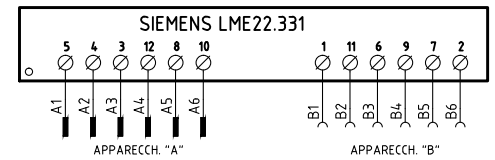

(#) MOTORE VENTIL. VERSIONE [A], FU2 = 6,3A F; MOTORE VENTIL. VERSIONE [B], FU2 = 10A F  
FAN MOTOR VERSION [A], FU2= 6,3 A F;  
FAN MOTOR VERSION [B], FU2= 10 A F

(x x x) SOLO CON ALIMENTAZIONE ELETTRICA SENZA NEUTRO  
WITH ELECTRIC SUPPLY WITHOUT NEUTRAL VERSION ONLY

ASCON KM3 HCRMMD										
14	12	7	8	10	9	11-13	4	1	2	3
⊗	⊗	⊗	⊗	⊗	⊗	⊗	⊗	⊗	⊗	⊗

600V RRR0-1-T73 (S)										
20	6	21	22	23	24	19-5	4	3	2	1
⊗	⊗	⊗	⊗	⊗	⊗	⊗	⊗	⊗	⊗	⊗

SIEMENS RWF50.2x											
K2	K3	IN	1P	L1	N	KQ	G-	G+	13	12	11
⊗	⊗	⊗	⊗	⊗	⊗	⊗	⊗	⊗	⊗	⊗	⊗

SIEMENS RWF55.5x													
K2	K3	IN	1P	L1	N	KQ	TE	13	G-	G+	14	12	11
⊗	⊗	⊗	⊗	⊗	⊗	⊗	⊗	⊗	⊗	⊗	⊗	⊗	⊗

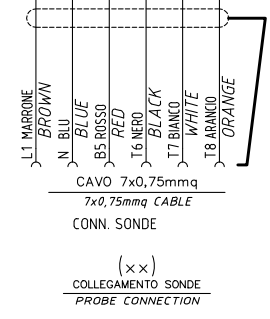

Data	19/10/2010	PREC.	FOGLIO
Revisione	05	2	3
Dis. N.	18 - 0163	SEQUE	TOTALE
		4	5

(xx)  
 ATTENZIONE COLLEGAMENTO SONDE CON CONNETTORE 7 POLI  
 WARNING PROBE CONNECTION WITH 7 PINS CONNECTOR

### KM3 HCRMMD

### 600V RRR0-1-T73

### RWF55.5x

### RWF50.2x

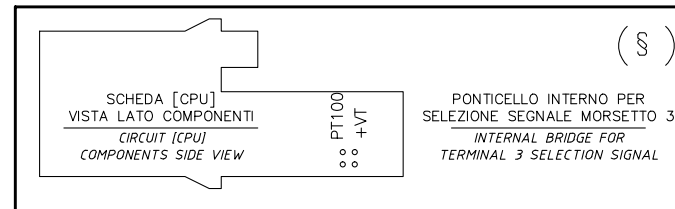
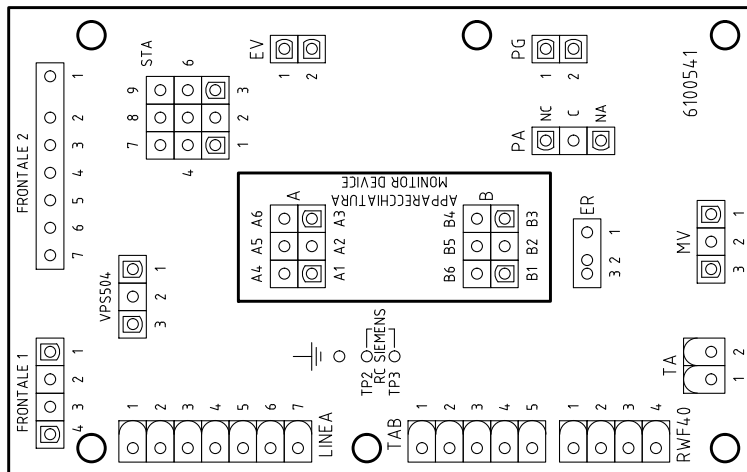
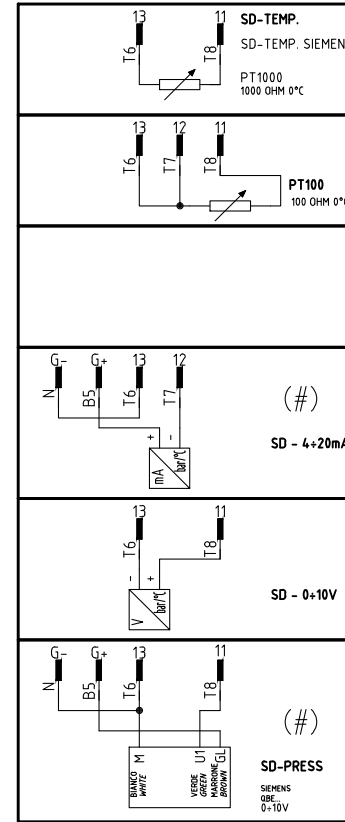
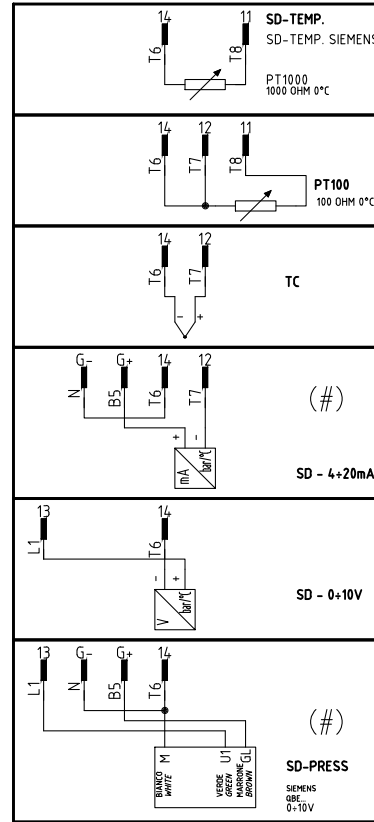
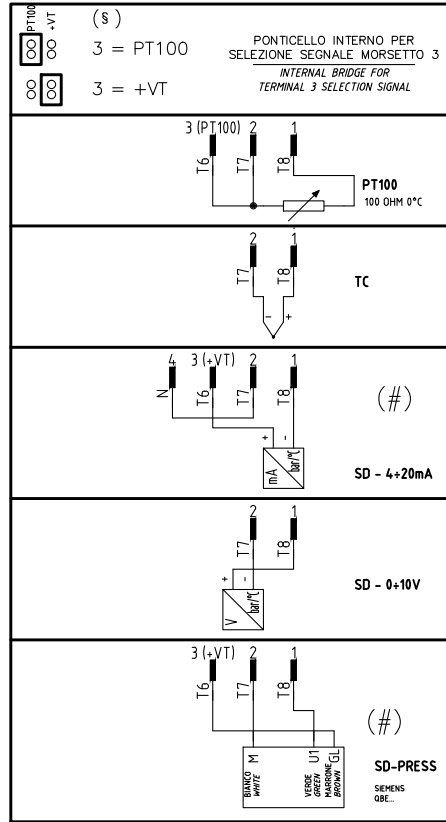
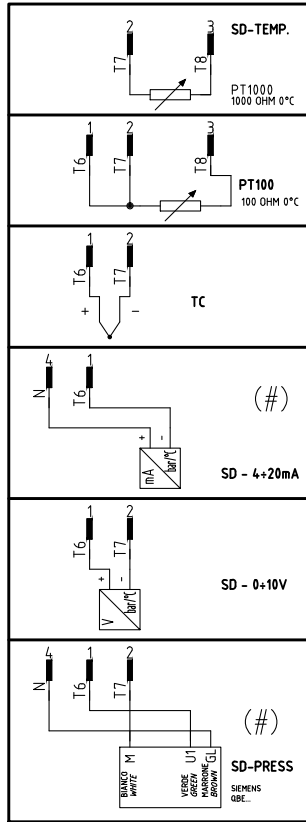

Data	19/10/2010	PREC.	FOGLIO
Revisione	05	3	4
Dis. N.	18 - 0163	SEGUE	TOTALE
		5	5

Sigla/Item	Funzione	Function
600V RRR0-1-T73	REGOLATORE MODULANTE (ALTERNATIVO)	BURNER MODULATOR (ALTERNATIVE)
C1	CONTAORE BASSA FIAMMA	LOW FLAME TIME COUNTER
C2	CONTAORE ALTA FIAMMA	HIGH FLAME TIME COUNTER
ER	ELETTRODO RILEVAZIONE FIAMMA	FLAME DETECTION ELECTRODE
EV1,2	ELETTROVALVOLE GAS (O GRUPPO VALVOLE)	GAS ELECTRO-VALVES (OR VALVES GROUP)
FU1	FUSIBILE LINEA MOTORE VENTILATORE	FAN MOTOR LINE FUSE
FU2	FUSIBILE DI LINEA	LINE FUSE
FU3	FUSIBILE DI LINEA	LINE FUSE
FU4	FUSIBILE AUSILIARIO	AUXILIARY FUSE
IL	INTERRUTTORE LINEA BRUCIATORE	BURNER LINE SWITCH
IM	INTERRUTTORE LINEA MOTORE VENTILATORE	FAN MOTOR LINE SWITCH
KM1.1	CONTATTORE MOTORE VENTILATORE	FAN MOTOR CONTACTOR
KM3 HCRMMD	REGOLATORE MODULANTE (ALTERNATIVO)	BURNER MODULATOR (ALTERNATIVE)
LAF	LAMPADA SEGNALAZIONE ALTA FIAMMA BRUCIATORE	BURNER IN HIGH FLAME INDICATOR LIGHT
LAF1	LAMPADA SEGNALAZIONE ALTA FIAMMA BRUCIATORE	BURNER IN HIGH FLAME INDICATOR LIGHT
LB	LAMPADA SEGNALAZIONE BLOCCO BRUCIATORE	INDICATOR LIGHT FOR BURNER LOCK-OUT
LB1	LAMPADA SEGNALAZIONE BLOCCO BRUCIATORE	INDICATOR LIGHT FOR BURNER LOCK-OUT
LBF	LAMPADA SEGNALAZIONE BASSA FIAMMA BRUCIATORE	BURNER IN LOW FLAME INDICATOR LIGHT
LBF1	LAMPADA SEGNALAZIONE BASSA FIAMMA BRUCIATORE	BURNER IN LOW FLAME INDICATOR LIGHT
LEV1	LAMPADA SEGNALAZIONE APERTURA [EV1]	INDICATOR LIGHT FOR OPENING OF ELECTRO-VALVE [EV1]
LEV2	LAMPADA SEGNALAZIONE APERTURA [EV2]	INDICATOR LIGHT FOR OPENING OF ELECTRO-VALVE [EV2]
LF	LAMPADA SEGNALAZIONE FUNZIONAMENTO BRUCIATORE	INDICATOR LIGHT BURNER OPERATION
LPG	LAMPADA SEGNALAZIONE PRESENZA GAS IN RETE	INDICATOR LIGHT FOR PRESENCE OF GAS IN THE NETWORK
LTA	LAMPADA SEGNALAZIONE TRASFORMATORE DI ACCENSIONE	IGNITION TRANSFORMER INDICATOR LIGHT
MV	MOTORE VENTILATORE	FAN MOTOR
PA	PRESSOSTATO ARIA	AIR PRESSURE SWITCH
PG	PRESSOSTATO GAS DI MINIMA PRESSIONE	MINIMUM GAS PRESSURE SWITCH
PS	PULSANTE SBLOCCO FIAMMA	FLAME UNLOCK BUTTON
PT100	SONDA DI TEMPERATURA	TEMPERATURE PROBE
RC	CIRCUITO RC	RC CIRCUIT
SD-PRESS	SONDA DI PRESSIONE	PRESSURE PROBE
SD-TEMP.	SONDA DI TEMPERATURA	TEMPERATURE PROBE
SD - 0÷10V	TRASDUTTORE USCITA IN TENSIONE	TRANSDUCER VOLTAGE OUTPUT
SD - 4÷20mA	TRASDUTTORE USCITA IN CORRENTE	TRANSDUCER CURRENT OUTPUT
SIEMENS LGB2x.330/LME2x.33x	APPARECCHIATURA CONTROLLO FIAMMA	CONTROL BOX
SIEMENS LME22.331	APPARECCHIATURA CONTROLLO FIAMMA	CONTROL BOX
SIEMENS RWF50.2x	REGOLATORE MODULANTE	BURNER MODULATOR
SIEMENS RWF55.5x	REGOLATORE MODULANTE (ALTERNATIVO)	BURNER MODULATOR (ALTERNATIVE)
SIEMENS SQN72.4A4A20	SERVOCOMANDO SERRANDA ARIA (ALTERNATIVO)	AIR DAMPER ACTUATOR (ALTERNATIVE)
SMA	SELETTORE MANUALE/AUTOMATICO	MANUAL/AUTOMATIC SWITCH
SMF	SELETTORE MANUALE FUNZIONAMENTO MIN-0-MAX	MIN-0-MAX MANUAL OPERATION SWITCH
ST	SERIE TERMOSTATI/PRESSOSTATI	SERIES OF THERMOSTATS OR PRESSURE SWITCHES
STA13B0.36/83N30L	SERVOCOMANDO SERRANDA ARIA	AIR DAMPER ACTUATOR
TA	TRASFORMATORE DI ACCENSIONE	IGNITION TRANSFORMER
TAB	TERMOSTATO/PRESSOSTATO ALTA-BASSA FIAMMA	HIGH-LOW THERMOSTAT/PRESSURE SWITCHES
TC	TERMOCOPPIA	THERMOCOUPLE
TS	TERMOSTATO/PRESSOSTATO DI SICUREZZA	SAFETY THERMOSTAT OR PRESSURE SWITCH
VPS50x	CONTROLLO DI TENUTA VALVOLE GAS (OPTIONAL)	GAS PROVING SYSTEM (OPTIONAL)

Data	19/10/2010	PREC.	FOGLIO
Revisione	05	4	5
Dis. N.	18 - 0163	SEGUE	TOTALE
		/	5