

**TP90A-TP91A
TP92A-TP93A
TP512A-TP515A
TP520A-TP525A**

***Gas burners
Microprocessor-controlled
LMV5x***

MANUAL OF INSTALLATION - USE - MAINTENANCE



BURNERS - BRUCIATORI - BRULERS - BRENNER - QUEMADORES - ГОРЕЛКИ

DANGERS, WARNINGS AND NOTES OF CAUTION

This manual is supplied as an integral and essential part of the product and must be delivered to the user.

Information included in this section are dedicated both to the user and to personnel following product installation and maintenance.

The user will find further information about operating and use restrictions, in the second section of this manual. we highly recommend to read it.

Carefully keep this manual for future reference.

The following:

Entails the customer's acknowledgement and acceptance of the company's general terms and conditions of sale, in force at the date of order confirmation and available in the appendix to the current price lists. Is intended exclusively for specialised, experienced and trained users able to operate in conditions that are safe for people, the device and the environment, and in full compliance with the requirements set out on the following pages and with current health and safety regulations. Information regarding assembly/installation, maintenance, replacement and repair is always and exclusively intended for (and therefore only to be carried out by) specialised personnel and/or directly by the Authorised Technical Service

IMPORTANT :

The supply has been made at the best conditions on the basis of the customer's order and technical indications concerning the state of the places and the installation systems, as well as the need to prepare certain certifications and / or additional adaptations with respect to the standard observed and transmitted for each product. In this respect, the manufacturer declines any responsibility for complaints, malfunctions, criticalities, damages and/or anything else consequent to incomplete, inaccurate and/or missing information, as well as failure to comply with the technical requirements and installation regulations, initial start-up, operational management and maintenance.

For proper operation of the device, it is necessary to ensure the readability and conservation of the manual, also for future reference. In case of deterioration or more simply for reasons of technical and operational insight, contact the manufacturer directly. Text, descriptions, images, examples and anything else contained in this document are the exclusive property of the manufacturer. Any reproduction is prohibited.

RISK ANALYSIS

Instruction manual delivered with the device:

This is an integral and essential part of the product and must not be separated from it. It must therefore be kept carefully for any necessary consultation and must accompany the burner even if it is transferred to another owner or user, or to another system. In the event of damage or loss, another copy must be requested from the local customer service centre;

Delivery of the system and instruction manual

The supplier of the system is obliged to accurately inform the user about:

- Use of the system;
- any further testing that may be necessary before activating the system;
- maintenance and the requirement to have the system checked at least once a year by a contractor or other specialised technician.

To ensure periodic monitoring, the manufacturer recommends drawing up a Maintenance Agreement.

WARRANTY AND LIABILITY

In particular, warranty and liability claims will no longer be valid in the event of damage to persons and/or property if such damage is due to any of the following causes:

- Incorrect installation, start-up, use and maintenance of the burner;
- Improper, incorrect or unreasonable use of the burner;
- Operation by unqualified personnel;
- Carrying out of unauthorised changes to the device;
- Use of the burner with safety devices that are faulty, incorrectly applied and/or not working;
- Installation of untested supplementary components on the burner;
- Powering of the burner with unsuitable fuels;
- Faults in the fuel supply system;
- Use of the burner even after an error and/or fault has occurred;
- Repairs and/or overhauls incorrectly carried out;
- Modification of the combustion chamber with inserts that prevent the regular development of the structurally established flame;
- Insufficient and inappropriate supervision and care of the burner components most subject to wear and tear;

- Use of non-original components, whether spare parts, kits, accessories and optionals;
- Force majeure.

Furthermore, the manufacturer declines all responsibility for non-compliance with this manual.



WARNING! Failure to comply with this manual, operational negligence, incorrect installation and unauthorised modifications will result in the manufacturer's warranty for the burner being voided.

Personnel training

The user is the person, organisation or company that has acquired the appliance and intends to use it for the specific purpose. The user is responsible for the appliance and for training the personnel that operate it.

The user:

- Undertakes to entrust the machine to suitably trained and qualified personnel;
- Must take all measures necessary to prevent unauthorised people gaining access to the appliance;
- Undertakes to adequately inform personnel about application and observance of the safety requirements, and therefore ensure that they are familiar with the operating instructions and safety requirements;
- Must inform the manufacturer if any faults or malfunctions of the accident prevention systems occur, and if there is any suspected danger;
- Personnel must always use the personal protective equipment required by law and follow the instructions provided in this manual;
- Personnel must observe all danger and caution notices on the appliance;
- Personnel must not carry out, on their own initiative, operations or interventions outside their area of expertise;
- Personnel must inform their superiors of any problem and danger that may arise;
- The assembly of parts of other makes, or any modifications made, may alter the characteristics of the appliance and may therefore compromise operational safety. The manufacturer therefore declines all responsibility for damages arising from the use of non-original parts.

GENERAL INTRODUCTION

- The equipment must be installed in compliance with the regulations in force, following the manufacturer's instructions, by qualified personnel.
- Qualified personnel means those having technical knowledge in the field of components for civil or industrial heating systems, sanitary hot water generation and particularly service centres authorised by the manufacturer.
- Improper installation may cause injury to people and animals, or damage to property, for which the manufacturer cannot be held liable.
- Remove all packaging material and inspect the equipment for integrity.

In case of any doubt, do not use the unit - contact the supplier.

The packaging materials (wooden crate, nails, fastening devices, plastic bags, foamed polystyrene, etc), should not be left within the reach of children, as they may prove harmful.

- Before any cleaning or servicing operation, disconnect the unit from the mains by turning the master switch OFF, and/or through the cutout devices that are provided.
- Make sure that inlet or exhaust grilles are unobstructed.
- In case of breakdown and/or defective unit operation, disconnect the unit. Make no attempt to repair the unit or take any direct action.

Contact qualified personnel only.

Units shall be repaired exclusively by a servicing centre, duly authorised by the manufacturer, with original spare parts and accessories.

Failure to comply with the above instructions is likely to impair the unit's safety.

To ensure equipment efficiency and proper operation, it is essential that maintenance operations are performed by qualified personnel at regular intervals, following the manufacturer's instructions.

- When a decision is made to discontinue the use of the equipment, those parts likely to constitute sources of danger shall be made harmless.
- In case the equipment is to be sold or transferred to another user, or in case the original user should move and leave the unit behind, make sure that these instructions accompany the equipment at all times so that they can be consulted by the new owner and/or the installer.
- This unit shall be employed exclusively for the use for which it is meant. Any other use shall be considered as improper and, therefore, dangerous.

The manufacturer shall not be held liable, by agreement or otherwise, for **WARNING!** Failure to observe the information given in this manual, operating negligence, incorrect installation and carrying out of non authorised modifications will result in the annulment by the manufacturer of the guarantee that it supplies with the burner.

The damages resulting from improper installation, use and failure to comply with the instructions supplied by the manufacturer. The occurrence of any of the following circumstances may cause explosions, polluting unburnt

gases (example: carbon monoxide CO), burns, serious harm to people, animals and things:

- Failure to comply with one of the WARNINGS in this chapter
- Incorrect handling, installation, adjustment or maintenance of the burner
- Incorrect use of the burner or incorrect use of its parts or optional supply

SPECIAL INSTRUCTIONS FOR BURNERS

- a Make the following checks:
- the burner should be installed in a suitable room, with ventilation openings complying with the requirements of the regulations in force, and sufficient for good combustion;
 - only burners designed according to the regulations in force should be used;
 - this burner should be employed exclusively for the use for which it was designed;
 - before connecting the burner, make sure that the unit rating is the same as delivery mains (electricity, gas oil, or other fuel);
 - observe caution with hot burner components. These are, usually, near to the flame and the fuel pre-heating system, they become hot during the unit operation and will remain hot for some time after the burner has stopped.

When the decision is made to discontinue the use of the burner, the user shall have qualified personnel carry out the following operations:

- a
- remove the power supply by disconnecting the power cord from the mains;
 - disconnect the fuel supply by means of the hand-operated shutoff valve and remove the control handwheels from their spindles.
- Special warnings**
- Make sure that the burner has, on installation, been firmly secured to the appliance, so that the flame is generated inside the appliance fire-box.
 - Before the burner is started and, thereafter, at least once a year, have qualified personnel perform the following operations:
 - a set the burner fuel flow rate depending on the heat input of the appliance;
 - b set the flow rate of the combustion-supporting air to obtain a combustion efficiency level at least equal to the lower level required by the regulations in force;
 - c check the unit operation for proper combustion, to avoid any harmful or polluting unburnt gases in excess of the limits permitted by the regulations in force;
 - d make sure that control and safety devices are operating properly;
 - e make sure that exhaust ducts intended to discharge the products of combustion are operating properly;
 - f on completion of setting and adjustment operations, make sure that all mechanical locking devices of controls have been duly tightened;
 - g make sure that a copy of the burner use and maintenance instructions is available in the boiler room.
 - In case of a burner shut-down, reset the control box by means of the RESET pushbutton. If a second shut-down takes place, call the Technical Service, without trying to RESET further.

The unit shall be operated and serviced by qualified personnel only, in compliance with the regulations in force.

GENERAL INSTRUCTIONS DEPENDING ON FUEL USED

ELECTRICAL CONNECTION

- For safety reasons the unit must be efficiently earthed and installed as required by current safety regulations.
- It is vital that all safety requirements are met. In case of any doubt, ask for an accurate inspection of electrics by qualified personnel, since the manufacturer cannot be held liable for damages that may be caused by failure to correctly earth the equipment.
- Qualified personnel must inspect the system to make sure that it is adequate to take the maximum power used by the equipment shown on the equipment rating plate. In particular, make sure that the system cable cross section is adequate for the power absorbed by the unit.
- No adaptors, multiple outlet sockets and/or extension cables are permitted to connect the unit to the electric mains.
- An omnipolar switch shall be provided for connection to mains, as required by the current safety regulations.
- The use of any power-operated component implies observance of a few basic rules, for example:
 - do not touch the unit with wet or damp parts of the body and/or with bare feet;
 - do not pull electric cables;
 - do not leave the equipment exposed to weather (rain, sun, etc.) unless expressly required to do so;
 - do not allow children or inexperienced persons to use equipment;
- The unit input cable shall not be replaced by the user. In case of damage to the cable, switch off the unit and contact qualified person-

nel to replace.

When the unit is out of use for some time the electric switch supplying all the power-driven components in the system should be switched off.

FIRING WITH GAS, LIGHT OIL OR OTHER FUELS GENERAL

General Warnings

- The burner shall be installed by qualified personnel and in compliance with regulations and provisions in force; wrong installation can cause injuries to people and animals, or damage to property, for which the manufacturer cannot be held liable.
- Before installation, it is recommended that all the fuel supply system pipes be carefully cleaned inside, to remove foreign matter that might impair the burner operation.
- Before the burner is commissioned, qualified personnel should inspect the following:
 - a the fuel supply system, for proper sealing;
 - b the fuel flow rate, to make sure that it has been set based on the firing rate required of the burner;
 - c the burner firing system, to make sure that it is supplied for the designed fuel type;
 - d the fuel supply pressure, to make sure that it is included in the range shown on the rating plate;
 - e the fuel supply system, to make sure that the system dimensions are adequate to the burner firing rate, and that the system is equipped with all the safety and control devices required by the regulations in force.
- When the burner is to remain idle for some time, the fuel supply tap or taps should be closed.

Special instructions for using gas

Have qualified personnel inspect the installation to ensure that:

- a the gas delivery line and train are in compliance with the regulations and provisions in force;
 - b all gas connections are tight;
 - c the boiler room ventilation openings are such that they ensure the air supply flow required by the current regulations, and in any case are sufficient for proper combustion.
- Do not use gas pipes to earth electrical equipment.
 - Never leave the burner connected when not in use. Always shut the gas valve off.
 - In case of prolonged absence of the user, the main gas delivery valve to the burner should be shut off.
- a **Precautions if you can smell gas** do not operate electric switches, the telephone, or any other item likely to generate sparks;
 - b immediately open doors and windows to create an air flow to purge the room;
 - c close the gas valves;

contact qualified personnel. Do not obstruct the ventilation openings of the room where gas appliances are installed, to avoid dangerous conditions such as the development of toxic or explosive mixtures.

Using oil pressure gauges

Generally, pressure gauges are equipped with a manual valve. Open the valve only to take the reading and close it immediately afterwards.

Safety and prevention

- Opening or tampering with the burner components is not allowed, apart from the parts requiring maintenance.
- Only those parts envisaged by the manufacturer can be replaced.

SYMBOLS USED



WARNING

Failure to observe the warning may result in irreparable damage (electrical or mechanical source respectively) to the unit or damage to the environment



DANGER!

Failure to observe the warning may result in serious injuries or death (electrical or mechanical source respectively).



This symbol distinguishes warnings of an annotative, reminder, general nature

TYPE OF FUEL USED



DANGER! The burner must be used only with the fuel specified in the burner data plate.

Type	--
Model	--
Year	--
S.Number	--
Output	--
Oil Flow	--
Fuel	--
Category	--
Gas Pressure	--
Viscosity	--
El.Supply	--
El.Consump.	--

BURNER SAFETY

The burners- and the configurations described below - comply with the regulations in force regarding health, safety and the environment. For more in-depth information, refer to the declarations of conformity that are an integral part of this Manual.



DANGER! Incorrect motor rotation can seriously damage property and injure people.



.Do not touch any mechanical moving parts with your hands or any other part of your body. Injury hazard

Do not touch any parts containing fuel (i.e. tank and pipes). Scalding hazard

Do not use the burner in situations other than the ones provided for in the data plate.

Do not use fuels other than the ones stated.

Do not use the burner in potentially explosive environments.

Do not remove or by-pass any machine safety devices.

Do not remove any protection devices or open the burner or any other component while the burner is running.

Do not disconnect any part of the burner or its components while the burner is running.

Untrained staff must not modify any linkages.

- After any maintenance, it is important to restore the protection devices before restarting the machine.

- All safety devices must be kept in perfect working order.

- Personnel authorized to maintain the machine must always be provided with suitable protections.



ATTENTION: while running, the parts of the burner near the generator (coupling flange) are subject to overheating. Where necessary, avoid any contact risks by wearing suitable PPE.



DIRECTIVES AND STANDARDS

Gas burners

European directives

2016/426/UE (appliances burning gaseous fuels)

2014/35/UE (Low Tension Directive)

2014/30/UE (Electromagnetic compatibility Directive)

2006/42/CE (Machinery Directive)

Harmonized standards

UNI EN 676 (Automatic forced draught burners for gaseous fuels)

EN 55014-1 (Electromagnetic compatibility- Requirements for household appliances, electric tools and similar apparatus)

EN 60204-1:2006 (Safety of machinery – Electrical equipment of machines.)

CEI EN 60335-1 (Specification for safety of household and similar electrical appliances);

CEI EN 60335-2-102 (Household and similar electrical appliances. Safety. Particular requirements for gas, oil and solid-fuel burning appliances having electrical connections).

UNI EN ISO 12100:2010 (Safety of machinery - General principles for design - Risk assessment and risk reduction);

Industrial burners

European directives

2006/42/CE (Machinery Directive)

2014/35/UE (Low Tension Directive)

2014/30/UE (Electromagnetic compatibility Directive)

2006/42/CE (Machinery Directive)

Harmonized standards

EN 746-2 (Industrial thermoprocessing equipment - Part 2: Safety requirements for combustion and fuel handling systems)

EN 55014-1 (Electromagnetic compatibility- Requirements for household appliances, electric tools and similar apparatus)

EN 60204-1:2006 (Safety of machinery – Electrical equipment of machines.)

CEI EN 60335-1 (Specification for safety of household and similar electrical appliances);

UNI EN ISO 12100:2010 (Safety of machinery - General principles for design - Risk assessment and risk reduction);

PARTE I: MANUAL DE INSTALACIÓN

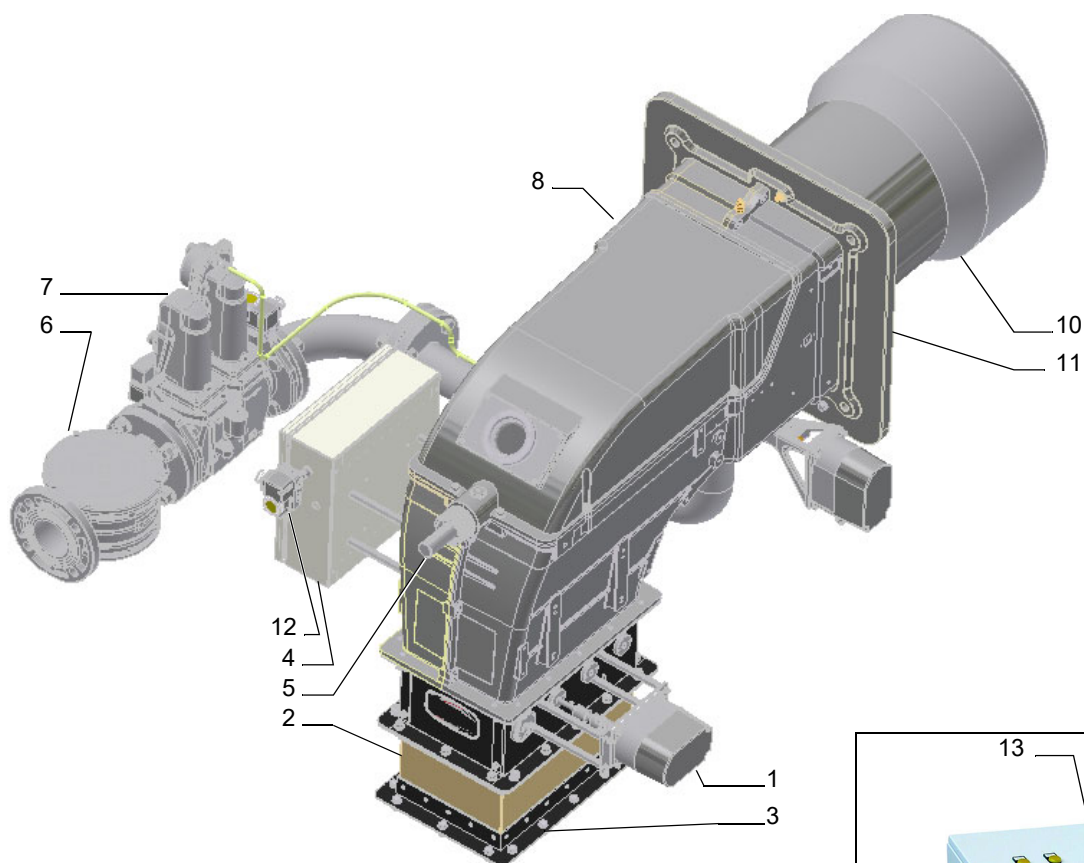

Nota: el dibujo es indicativo

- 1 Servomando
- 2 Fuelle
- 3 Brida del canal de aire
- 4 Caja de derivación
- 5 Tuerca regulación cabezal
- 6 Filtro gas
- 7 Grupo valvulas gas
- 8 Tapa
- 9 Ignitor gas train
- 10 Combustion head-blast tube ass.y
- 11 Brida
- 12 Presóstato aire
- 13 Panel de control con atril independiente



El gas que proviene de la red de distribución pasa a través del grupo de válvulas que cuentan con filtro y estabilizador. Este último mantiene la presión dentro de los límites de utilización. El servomando eléctrico que actúa de manera proporcional sobre los registros de regulación del caudal de aire comburente y sobre la válvula de mariposa de gas, permite optimizar los valores del gas de descarga y, por tanto, obtener una eficaz combustión. La colocación de la cabeza de combustión determina la potencia del quemador. El combustible y el comburente se encanalan en vías geométricas separadas hasta que se encuentran en la zona de desarrollo de la llama (cámara de combustión). El panel sinóptico presente en la parte delantera del quemador indica las etapas de funcionamiento

CARACTERÍSTICAS GENERALES

Los quemadores industriales de esta serie están estudiados para instalaciones en las que se requiere un ventilador de grandes dimensiones o un intercambiador de calor aire-humos, para instalar separado del quemador para disminuir el ruido. Están disponibles con cuadro eléctrico instalado o separado (en pared o en atril).

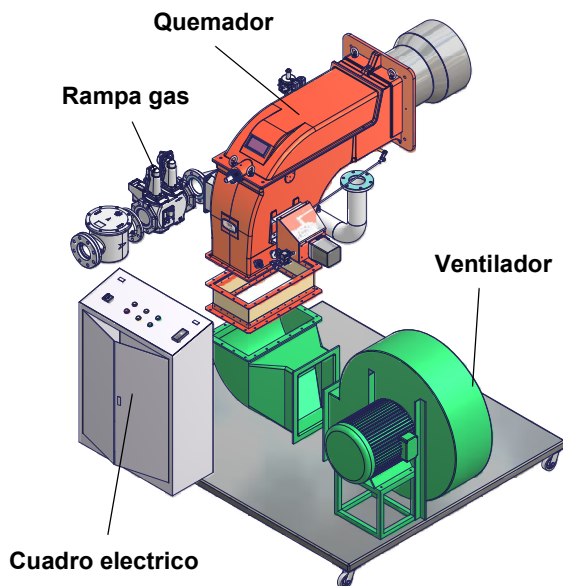

Nota: la figura es meramente indicativa. El ventilador y el cuadro eléctrico se pueden emplazar según lo desee el cliente.

Cómo interpretar el "Campo de trabajo" del quemador

El quemador y sus componentes deben elegirse en función de diversos parámetros, como:

- Combustible
- Energía del generador en el hogar
- Tipo de caldera
- Tipo de cámara de combustión (por inversión o por llama)
- Temperatura o presión del fluido caloportador
- Temperatura del aire de combustión
- Posición del conducto de alimentación de aire de combustión
- Presión en la cámara de combustión
- Altitud sobre el nivel del mar en la que se va a instalar el quemador
- Tren de gas (sólo gas y mixto)
- Unidad de empuje (sólo para quemadores de gasóleo, gasóleo y doble combustible)
- Ventilador de aire de combustión
- Cuadro eléctrico a bordo o separado

Tenga en cuenta también que los quemadores con panel de control integrado se fabrican de serie con un grado de protección eléctrica de IP40. Para una protección diferente, póngase en contacto con la oficina técnica del fabricante.

Ejemplo:

- Potencia en el hogar del calentador: 9600 kW
- Temperatura del aire de combustión: 15 °C
- Altitud sobre el nivel del mar: 0 m

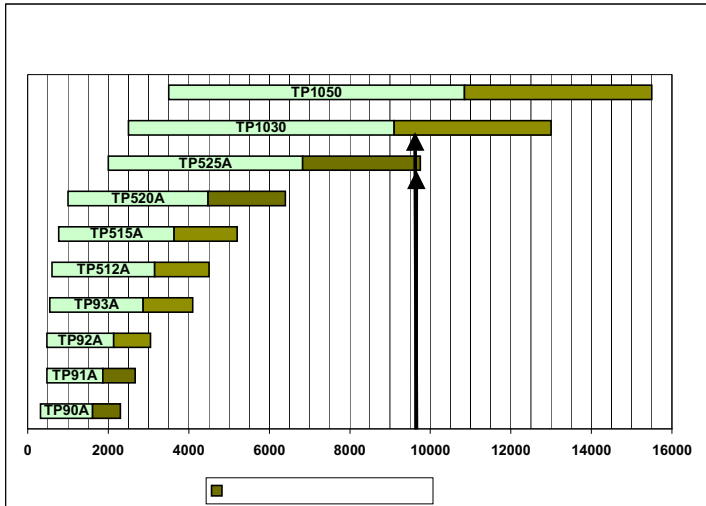

Analice el diagrama resumen de la Fig. 1 para identificar qué quemador o quemadores se encuentran dentro de este rango de potencia (9600 kW). Una vez identificados los tipos de quemadores, hay que elegir el más adecuado en función de razones técnicas y económicas.

Las razones técnicas se resumen en la mayor relación de modulación (menos encendidos, menor consumo, menos fluctuaciones de temperatura y presión del generador).

Comprobación del diámetro correcto de la rampa de gas

Para comprobar el diámetro correcto de la rampa de gas es necesario conocer la presión del gas disponible antes de las válvulas de gas del quemador. Luego, a esta presión se debe sustraer la presión en la cámara de combustión. El dato final será denominado p_{gas} . Ahora, trazar una recta vertical en correspondencia con el valor de potencia del generador de calor (el ejemplo, 600 kW), indicado en la abscisa, hasta encontrar la curva de presión en la red correspondiente al diámetro de la rampa montada en el quemador en examen (DN65 en este ejemplo). Desde el punto de intersección, trazar una recta horizontal hasta encontrar, en la ordenada, el valor de presión necesario para desarrollar la potencia requerida por el generador. El valor leído deberá ser igual o inferior al valor p_{gas} , calculado anteriormente.

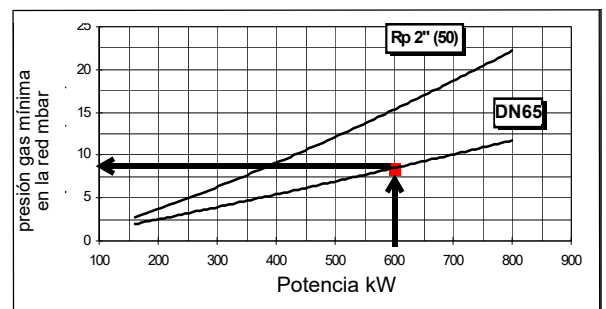
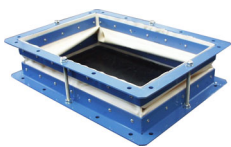

Fig. 1 - Instalación del ventilador



Conecte el conducto de aire al quemador utilizando los fuelles suministrados con el quemador (vea la figura a continuación)



¡ATENCIÓN! El fuelle incluido en el equipamiento es de tela y está equipado con distanciadores de bloqueo, para evitar que se rompa durante el montaje: montar primero el fuelle entre las bridas y, después, extraer los distanciadores de bloqueo.

¡ATENCIÓN! El dimensionamiento del conducto de aire debe ser realizado de acuerdo con el caudal, la temperatura del aire, la distancia del ventilador del quemador y las características del ventilador

Identificación de los quemadores

Los quemadores se identifican por tipo y modelo. Seguidamente se ilustran los modelos.

Tipo TP520A (1)	Modelo M- (2)	MD. (3)	S. (4)	*. (5)	Y. (6)	8. (7)	65 (8)	EO (9)
(1) QUEMADOR TIPO	TP90A, TP91A, TP92A, TP93A, TP512A, TP515A, TP520A, TP525A							
(2) COMBUSTIBLE	M - Gas natural L - LPG							
(3) FUNCIONAMIENTO (Versiones disponibles)	PR - Progresivo, MD - Modulante							
(4) TOBERA	S - Estándar							
(5) PAIS DE DESTINO	* - veas placa dos datos del quemador							
(6) VERSIONES	A - Estándar, Y - Especial							
(7) EQUIPAMIENTO (Versiones disponibles)	1 = 2 Válvulas + control de estenquedad 8 = 2 Válvulas + control de estenquedad + presostato gas de maxima							
(8) DIÁMETRO RAMPA (Véase características técnicas)	50 = Rp2		65 = DN65					
	80 = DN80		100 = DN100					
(9) QUEMADOR A CONTROL ELECTRÓNICO	ES = sin control oxígeno y sin inverter EO = con control oxígeno y sin inverter EI = sin control oxígeno y con inverter EK = con control oxígeno y con inverter							

Tipo de combustible utilizado



ADVERTENCIA! El quemador debe ser utilizado solamente con el combustible especificados en la placa del quemador.

Tipo	--
Modelo	--
Año	--
N°serie	--
Potencia	--
Caudal	--
Combustible	--
Categoría	--
Presión	--
Viscosidad	--
Tensión	--

Las características técnicas de los quemadores, indicadas en este manual, corresponden al gas natural (poder calorífico Hi = 9.45 kWh/Stm³, densidad ρ = 0.717Kg/Stm³). Para combustible como GPL, gas ciudad y biogas, multiplicar los valores y presión para los coeficientes correctivos indicados en la tabla.

Combustible	Hi (KWh/Stm ³)	ρ (kg/Stm ³)	f _Q	f _p
LPG	26,79	2,151	0,353	0,4
Gas ciudad	4,88	0,6023	1,936	3,3
Biogas	6,395	1,1472	1,478	3,5

Por ejemplo, para calcular el caudal y la presión para biogas:

$$Q_{biogas} = Q_{naturalGas} \cdot 1,478$$

$$P_{biogas} = P_{naturalGas} \cdot 3,5$$



ADVERTENCIA! El tipo y el ajuste de la cabeza de combustión depende del tipo de gas quemado. El quemador debe ser utilizado para el fin previsto especificados en la placa del quemador.



ATENCIÓN! Los factores correctivos indicados en la tabla dependen de la composición del combustible y, por ende, de su poder calorífico Hi y densidad ρ. Los valores indicados arriba deben considerarse exclusivamente como valores de referencia.

Características técnicas

Nota: los valores de Potencia son válidos para temperaturas del aire comburente inferiores a 50 °C.

QUEMADOR TIPO		TP90A	TP91A	TP92A	TP93A
Potencialidad	min. - max. kW	320-2.300	480 - 2.670	480 - 3.050	550 - 4.100
Combustible		Gas natural			
Categoría		(veas parrafo siguiente)			
Caudal de gas	min. - max. (Stm ³ /h)	34 - 243	51 - 283	51 - 323	58 - 434
Alimentación eléctrica		230V 3~ / 400V 3N~ 50Hz			
Potencia eléctrica total (excluido el	kW	0,5			
Potencia eléctrica ventiladorl	kW	veas placa dos datos del quemador			
Protección		IP54			
Tipo de regulación		Progresivo - Modulante			
Presion		(veas Nota2)			
Rampa gas 50	∅Valvulas / Conexión gas	2" / Rp 2			
Rampa gas 65	∅Valvulas / Conexión gas	2"1/2 / DN65			
Rampa gas 80	∅Valvulas / Conexión gas	3" / DN80			
Rampa gas 100	∅ Valvulas / Conexión gas	4" / DN100			
Temperatura de funcionamiento	°C	-10 ÷ +50			
Temperatura de almacenamiento	°C	-20 ÷ +60			
Tipo de servicio		Continuo			

QUEMADOR TIPO		TP512A	T515A	T520A	TP525A
Potencialidad	min. - max. kW	600-4.500	770 - 5.200	1.000 - 6.400	2.000 - 9.750
Combustible		Gas natural			
Categoría		(veas parrafo siguiente)			
Caudal de gas	min. - max.(Stm ³ /h)	63.5 - 476	81.5 - 550	106 - 677	212 - 1032
Alimentación eléctrica		230V 3~ / 400V 3N~ 50Hz			
Potencia eléctrica total (excluido el	kW	0,5			
Potencia eléctrica ventiladorl	kW	veas placa dos datos del quemador			
Protección		IP54			
Tipo de regulación		Progresivo - Modulante			
Presion		(veas Nota2)			
Rampa gas 50	∅Valvulas / Conexión gas	2" / Rp 2			
Rampa gas 65	∅Valvulas / Conexión gas	2"1/2 / DN65			
Rampa gas 80	∅Valvulas / Conexión gas	3" / DN80			
Rampa gas 100	∅ Valvulas / Conexión gas	4" / DN100			
Temperatura de funcionamiento	°C	-10 ÷ +50			
Temperatura de almacenamiento	°C	-20 ÷ +60			
Tipo de servicio		Continuo			

* Fan supplied separately, OPTIONAL

Nota 1:	todos los caudales gas le están en Stm3/h, presión 1013 mbar y temperatura 15° C, y valen por Gas G20, capacidad calorífica inferior H _i = 34.02 MJ/Stm ³ .
Nota 2:	Presión gas maxima = 500 mbar, con válvulas Siemens VGD.. / Dungs MBC.. Presión gas minima = ves curvas

Categorías gas y países de destino

CATEGORÍA	PAÍS																								
	AT	ES	GR	SE	FI	IE	HU	IS	NO	CZ	DK	GB	IT	PT	CY	EE	LV	SI	MT	SK	BG	LT	RO	TR	CH
I _{2H}																									
I _{2E}	LU	PL	-	-	-	-	-	-	-	-	-	-	-	-	-	-	-	-	-	-	-	-	-	-	-
I _{2E(R)B}	BE	-	-	-	-	-	-	-	-	-	-	-	-	-	-	-	-	-	-	-	-	-	-	-	-
I _{2L}	NL	-	-	-	-	-	-	-	-	-	-	-	-	-	-	-	-	-	-	-	-	-	-	-	-
I _{2ELL}	DE	-	-	-	-	-	-	-	-	-	-	-	-	-	-	-	-	-	-	-	-	-	-	-	-
I _{2Er}	FR	-	-	-	-	-	-	-	-	-	-	-	-	-	-	-	-	-	-	-	-	-	-	-	-

Dimensiones (mm)

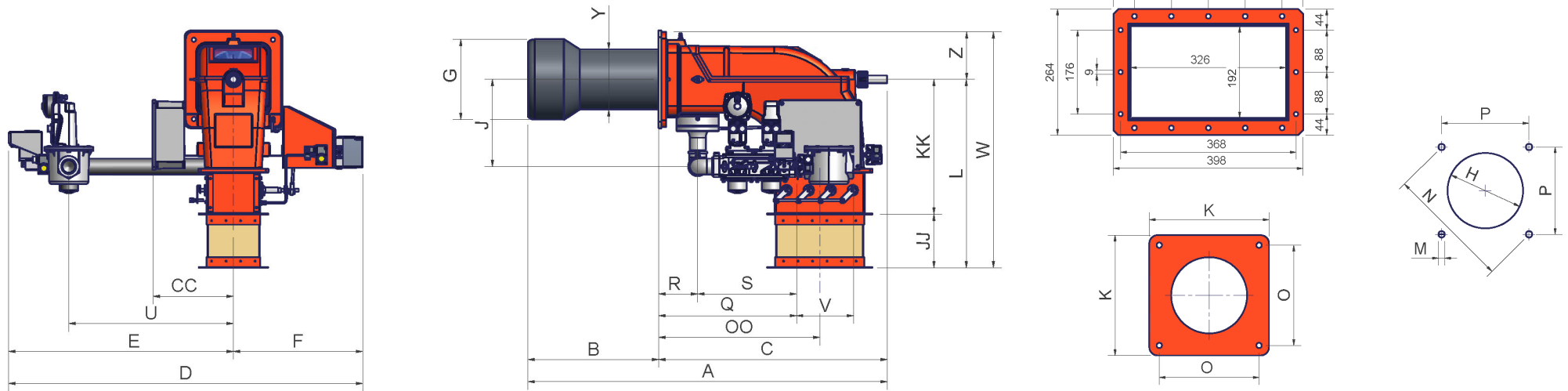

Brida del canal de aire y brida del quemador Plantilla de perforación recomendada

	DN	A	B	C	CC	D	E	F	G	H	J	JJ	K	KK	L	M	N	O min	O max	OO	P	Q	R	S	U	V	W	Y	Z
TP90A	50	1356	490	866	305	1342	852	490	234	264	329	185	360	510	695	M12	424	280	310	610	300	522	148	374	624	216	875	198	180
TP90A	65	1356	490	866	305	1447	957	490	234	264	288	185	360	510	695	M12	424	280	310	610	300	551	148	403	750	293	875	198	180
TP90A	80	1356	490	866	305	1449	959	490	234	264	307	185	360	510	695	M12	424	280	310	610	300	592	148	444	750	322	875	198	180
TP90A	100	1356	490	866	305	1539	1049	490	234	264	447	185	360	510	695	M12	424	280	310	610	300	672	148	524	824	382	875	198	180
TP91A	50	1356	490	866	305	1342	852	490	265	295	329	185	360	510	695	M12	424	280	310	610	300	522	148	374	624	216	875	228	180
TP91A	65	1356	490	866	305	1447	957	490	265	295	288	185	360	510	695	M12	424	280	310	610	300	551	148	403	750	293	875	228	180
TP91A	80	1356	490	866	305	1449	959	490	265	295	307	185	360	510	695	M12	424	280	310	610	300	592	148	444	750	322	875	228	180
TP91A	100	1356	490	866	305	1539	1049	490	265	295	447	185	360	510	695	M12	424	280	310	610	300	672	148	524	824	382	875	228	180
TP92A	50	1356	490	866	305	1342	852	490	269	299	329	185	360	510	695	M12	424	280	310	610	300	522	148	374	624	216	875	228	180
TP92A	65	1356	490	866	305	1447	957	490	269	299	288	185	360	510	695	M12	424	280	310	610	300	551	148	403	750	293	875	228	180
TP92A	80	1356	490	866	305	1449	959	490	269	299	307	185	360	510	695	M12	424	280	310	610	300	592	148	444	750	322	875	228	180
TP92A	100	1356	490	866	305	1539	1049	490	269	299	447	185	360	510	695	M12	424	280	310	610	300	672	148	524	824	382	875	228	180
TP93A	50	1361	495	866	305	1342	852	490	304	344	329	185	360	510	695	M12	424	280	310	610	300	522	148	374	624	216	875	228	180
TP93A	65	1361	495	866	305	1447	957	490	304	344	288	185	360	510	695	M12	424	280	310	610	300	551	148	403	750	293	875	228	180
TP93A	80	1361	495	866	305	1449	959	490	304	344	307	185	360	510	695	M12	424	280	310	610	300	592	148	444	750	322	875	228	180
TP93A	100	1361	495	866	305	1539	1049	490	304	344	447	185	360	510	695	M12	424	280	310	610	300	672	148	524	824	382	875	228	180

DN = diámetro válvulas gas.

NOTA: las dimensiones de estorbo son referidas a quemadores abastecidos de válvulas Siemens mod. VGD.

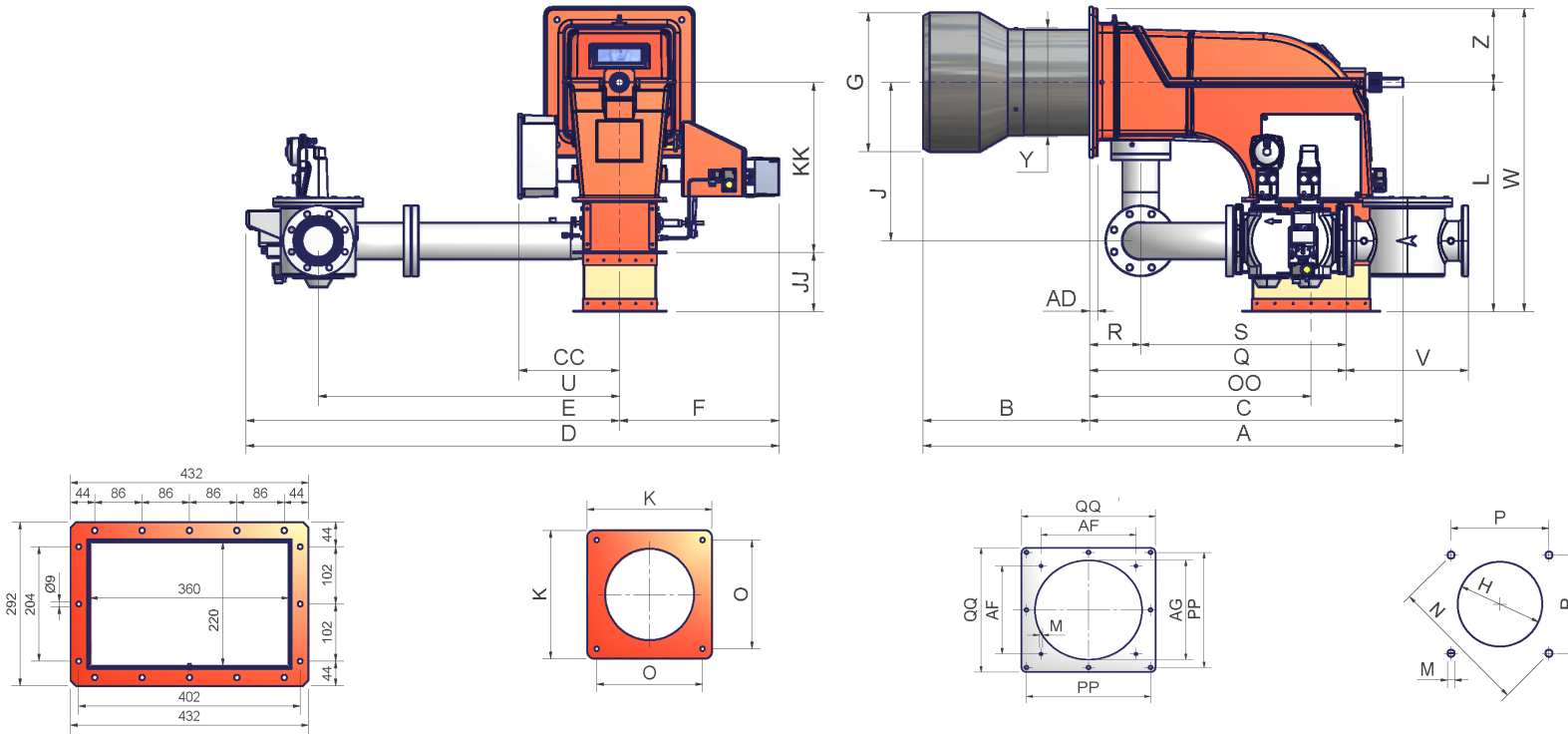

Brida del canal de aire

Brida del quemador

Contrabrida recomendada

Plantilla de perforación recomendada

	DN	A	AD	AF	AG	B	C	CC	D	E	F	G	H	J	JJ	K	KK	L	M	N	O	OO	P	PP	Q	QQ	R	S	U	V	W	Y	Z
TP512A	50	1475	25	x	x	520	955	314	1477	978	499	340	380	337	185	540	530	715	M12	552	390	693	390	x	685	x	160	525	750	216	945	328	230
TP512A	65	1475	25	x	x	520	955	314	1456	957	499	340	380	337	185	540	530	715	M12	552	390	693	390	x	563	x	160	403	750	292	945	328	230
TP512A	80	1475	25	x	x	520	955	314	1458	959	499	340	380	354	185	540	530	715	M12	552	390	693	390	x	604	x	160	444	750	322	945	328	230
TP512A	100	1475	25	x	x	520	955	314	1548	1049	499	340	380	392	185	540	530	715	M12	552	390	693	390	x	684	x	160	524	824	382	945	328	230
TP515A	50	1491	25	x	x	520	971	314	1477	978	499	380	420	337	185	540	530	715	M12	552	390	693	390	x	685	x	160	525	750	216	945	328	230
TP515A	65	1491	25	x	x	520	971	314	1456	957	499	380	420	337	185	540	530	715	M12	552	390	693	390	x	563	x	160	403	750	292	945	328	230
TP515A	80	1491	25	x	x	520	971	314	1458	959	499	380	420	354	185	540	530	715	M12	552	390	693	390	x	604	x	160	444	750	322	945	328	230
TP515A	100	1491	25	x	x	520	971	314	1548	1049	499	380	420	392	185	540	530	715	M12	552	390	693	390	x	684	x	160	524	824	382	945	328	230
TP520A	50	1497	25	x	x	520	977	314	1477	978	499	400	440	337	185	540	530	715	M12	552	390	693	390	x	685	x	160	525	750	216	945	340	230
TP520A	65	1497	25	x	x	520	977	314	1456	957	499	400	440	337	185	540	530	715	M12	552	390	693	390	x	563	x	160	403	750	292	945	340	230
TP520A	80	1497	25	x	x	520	977	314	1458	959	499	400	440	354	185	540	530	715	M12	552	390	693	390	x	604	x	160	444	750	322	945	340	230
TP520A	100	1497	25	x	x	520	977	314	1548	1049	499	400	440	392	185	540	530	715	M12	552	390	693	390	x	684	x	160	524	824	382	945	340	230
TP525A	50	1497	25	390	440	520	977	314	1570	1071	499	434	484*	494	185	540	530	715	M12	721*	390	693	510*	510*	765	550*	160	605	843	216	945	340	230
TP525A	65	1497	25	390	440	520	977	314	1548	1049	499	434	484*	494	185	540	530	715	M12	721*	390	693	510*	510*	643	550*	160	483	843	292	945	340	230
TP525A	80	1497	25	390	440	520	977	314	1583	1084	499	434	484*	494	185	540	530	715	M12	721*	390	693	510*	510*	695	550*	160	535	875	322	945	340	230
TP525A	100	1497	25	390	440	520	977	314	1666	1167	499	434	484*	494	185	540	530	715	M12	721*	390	693	510*	510*	802	550*	160	642	942	382	945	340	230

DN = diámetro válvulas gas.

* Montar una contrabrida entre quemador y caldera. La alternativa es hacer el agujero H más pequeño, pero superior a la medida Y y montar la tobera al interior de la caldera.

NOTA: las dimensiones de estorbo son referidas a quemadores abastecidos de válvulas Siemens mod. VGD.

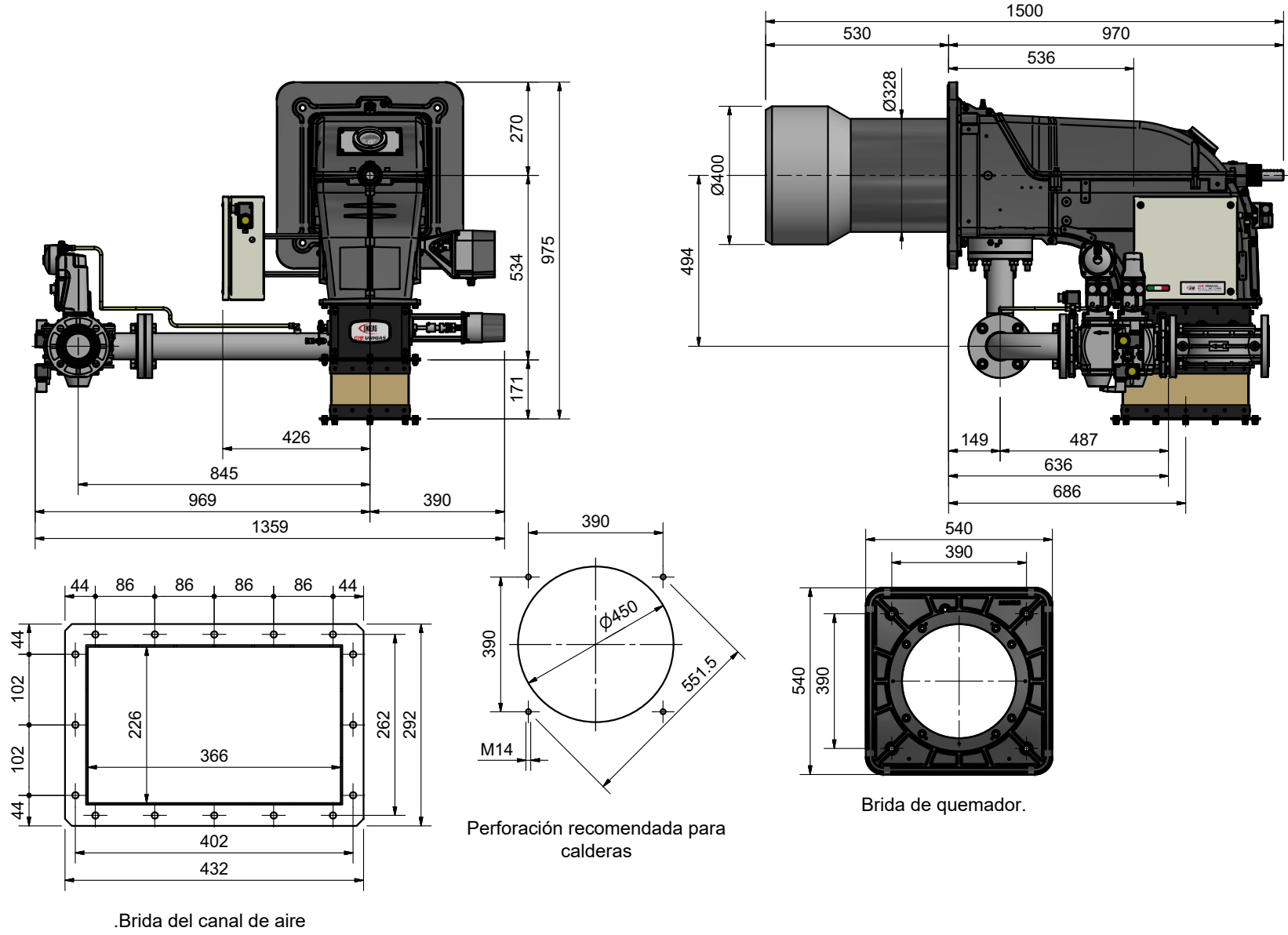

.Brida del canal de aire

Perforación recomendada para calderas

Brida de quemador.

DIAGRAMAS HIDRÁULICOS RAMPAS DE GAS



ATENCIÓN: Antes de realizar las conexiones a la red de distribución de gas, asegúrese de que las válvulas de cierre manual estén cerradas. lea atentamente el capítulo "advertencias" de este manual.

Los siguientes diagramas muestran algunos ejemplos de posibles rampas de gas con los componentes suministrados con el quemador y los montados por el instalador. Los rampas de gas y la conexión del quemador a la línea de suministro de combustible deben realizarse de acuerdo con la normativa local vigente.

Fig. 2 - Esquema hidráulico

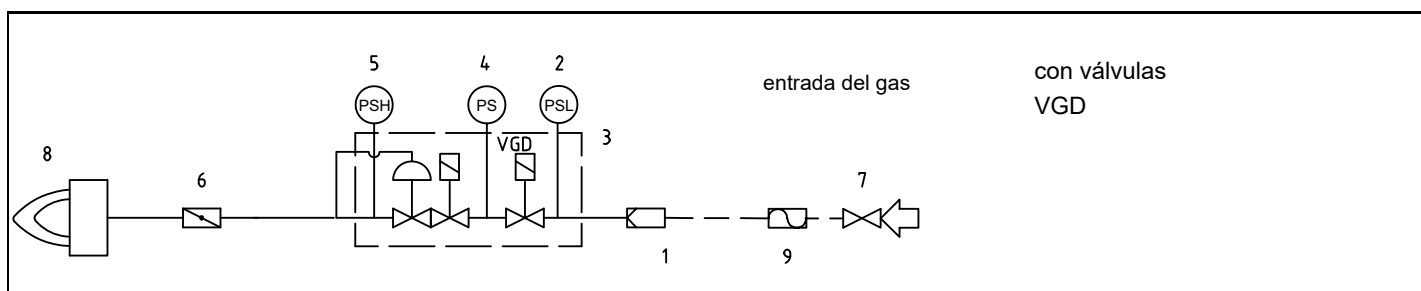
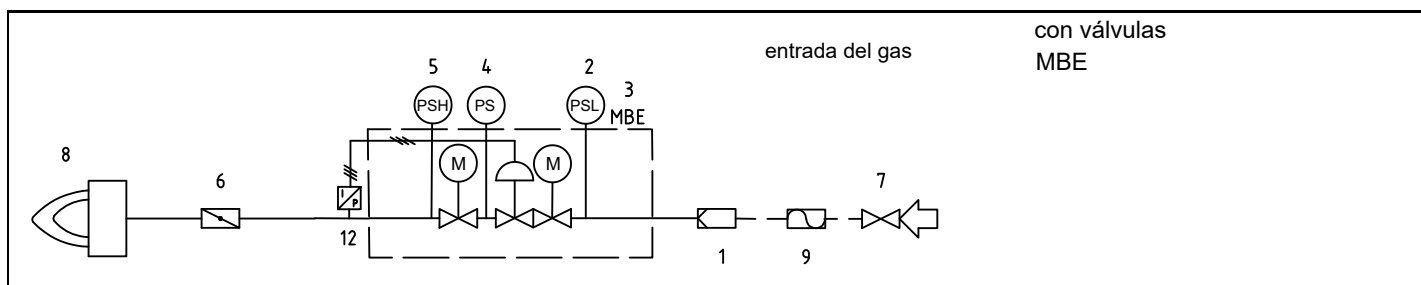
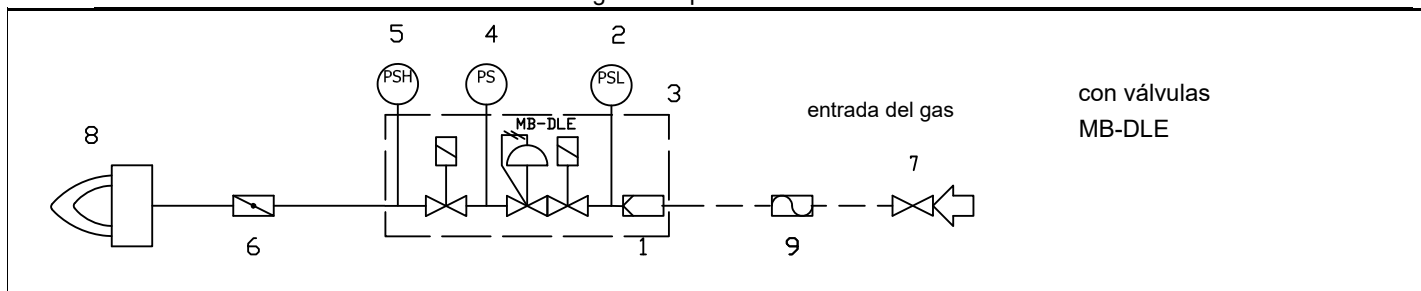

Leyenda:

- 1 filtro
- 2 Presostato de baja presión - PGMIN
- 3 Válvula de seguridad
- 4 presóstato de gas control de pérdidas - PGCP
- 5 Presostato de alta PGMAX: obligatorio para MBE, opcional para VGD y DMV-DLE
- 6 Válvula mariposa
- 7 Válvula manual aguas arriba (por el instalador o suministrado como opción)
- 8 Quemador
- 9 Junta antivibrante (por el instalador o suministrado como opción)
- 12 Sensor de presión MBE



ATENCIÓN: La prueba de estanqueidad es obligatoria en los quemadores con una potencia superior a 1200 kW. Para los quemadores con una potencia inferior, la prueba de estanqueidad es opcional.



ATENCIÓN: Según la norma EN676, es obligatorio instalar un grifo y una junta antivibratoria antes de las válvulas de seguridad de la tubería de gas.

CURVAS DE PRESIÓN - CAUDAL EN LA RED (gas natural)

TP90A

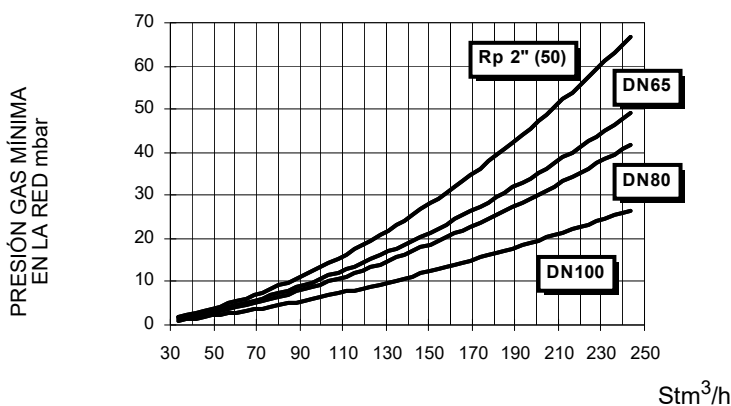

TP91A

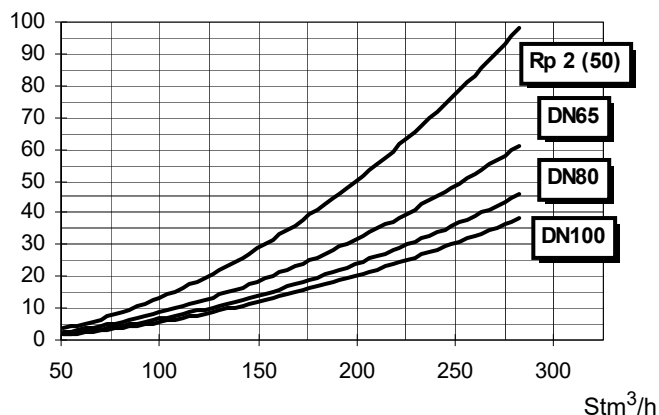

TP92A

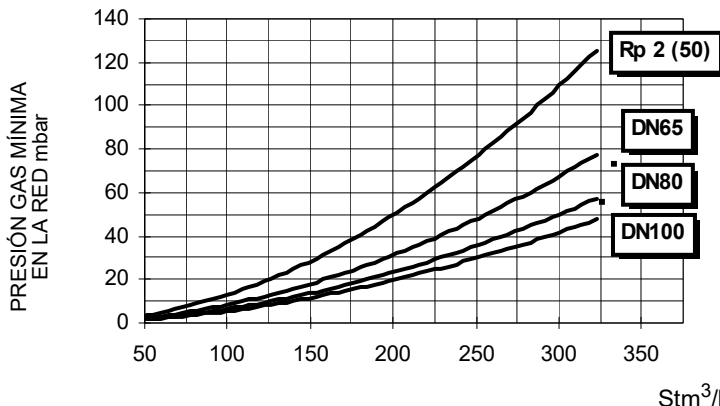

TP93A

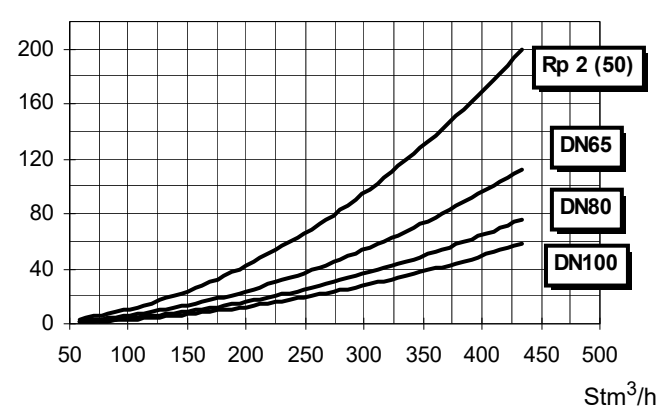

TP512A

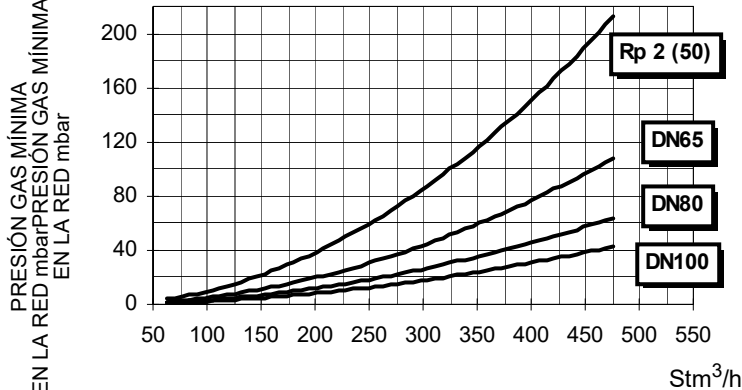

TP515A

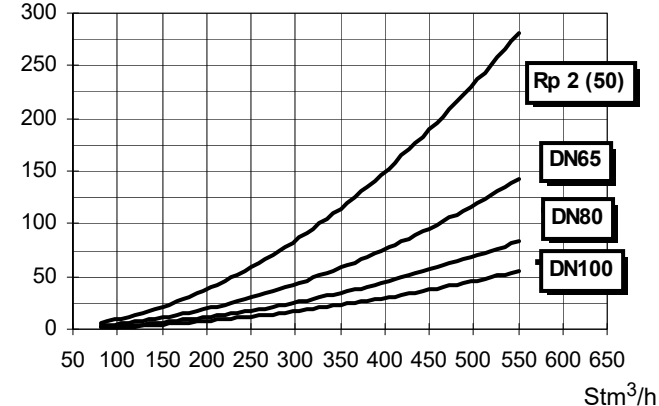

TP520A

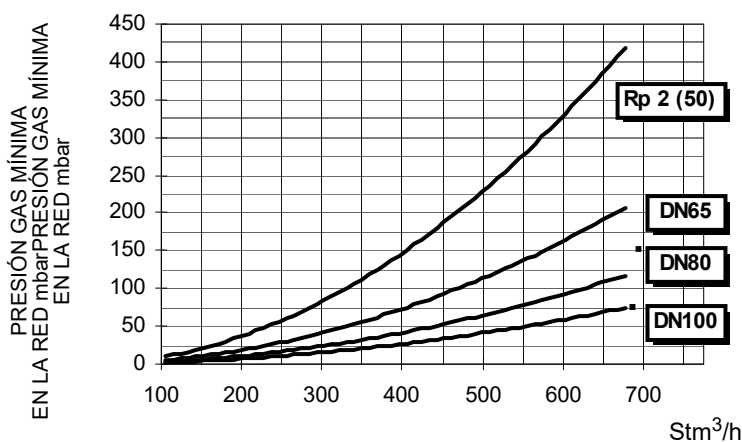

TP525A

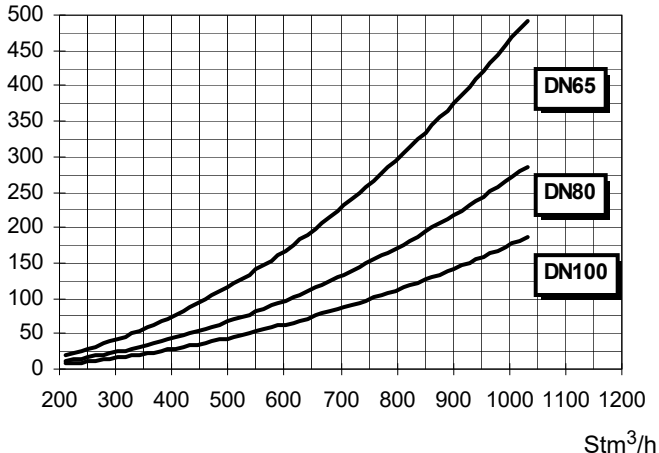

Atención: en abscisa es representado el valor del caudal gas, en entrada el correspondiente valor de presión en red a lo neto de la presión en cámara de combustión. Para conocer la presión mínima en entrada rampa, necesaria para conseguir el caudal gas solicitado, hace falta sumar la presión en cámara de combustión al valor leído en grafico.

MONTAJE Y CONEXIONES

Los embalajes que contienen los quemadores deben estar bloqueados en el interior del medio de transporte para garantizar la ausencia de movimientos peligrosos y evitar posibles daños.

En caso de almacenamiento, los quemadores deben almacenarse en su embalaje, en almacenes protegidos de los elementos. Evite los lugares húmedos o corrosivos y respete las temperaturas indicadas en la tabla de datos del quemador al principio de este manual.

Embalajes

Los quemadores se entregan en embalajes con las siguientes dimensiones

series 9xA : 1730mm x 1280mm x 1020mm (Lx P x H)

series 5xxA : 1730mm x 1430mm x 1130mm (Lx P x H)

Dichos embalajes se perjudican con la humedad y no puede superarse la cantidad máxima de embalajes superpuestos indicados en la parte exterior del mismo. En el interior de cada embalaje hay:

- quemador
- junta a colocar entre el quemador y la caldera;
- juntura antivibrante por el canal de aire;
- sobre con este manual.

Para eliminar el embalaje del quemador y en el caso de desguace de este último, siga los procedimientos previstos por las leyes vigentes relativas a la eliminación de los materiales.

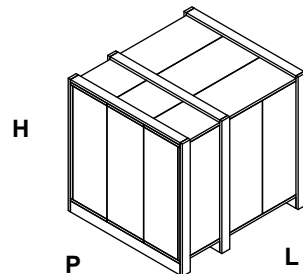

Levantamiento y desplazamiento del quemador

	<p>¡ATENCIÓN! Las operaciones de levantamiento y desplazamiento deben ser llevadas a cabo por personal especializado y entrenado para el desplazamiento de las cargas. En caso que estas operaciones no sean realizadas correctamente, existe el riesgo residual de vuelco y caída de la máquina!</p>
	<p>Para el desplazamiento utilizar medios con capacidad adecuada para el peso que se debe sostener (consultar el apartado "Características técnicas").</p>

El quemador está equipado con cáncamos de elevación.

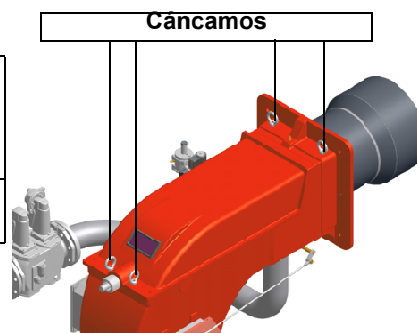

Montaje del quemador a la caldera

Para instalar el quemador en la caldera proceda de la siguiente manera:

- 1 perforar la placa de cierre de la cámara de combustión como se describe en el párrafo ("Dimensiones ocupadas");
- 2 acercar el quemador a la placa de la caldera: levantar y desplazar el quemador utilizando un montacargas (ver el párrafo "Levantamiento y desplazamiento");
- 3 en correspondencia con la puerta de la caldera, coloque los 4 prisioneros (5) según el patrón de perforación descrito en el párrafo "Dimensiones ocupadas";
- 4 enroscar los prisioneros (5);
- 5 colocar la junta en la brida del quemador;
- 6 montar el quemador en la caldera;
- 7 fijar con las tuercas los prisioneros de la caldera según el esquema indicado en la figura.
- 8 Una vez terminado el montaje del quemador en la caldera, sellar el espacio entre el tubo y el material comprimido refractario, con material aislante (cordón de fibra resistente a la temperatura o cemento refractario).

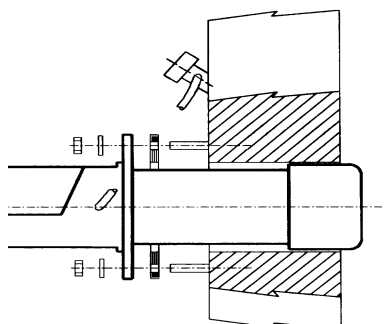

Leyenda

- 1 Quemador
- 2 Tuerca de fijación
- 3 Arandela
- 4 Junta
- 5 Tornillo prisionero
- 6 Tubo limpieza vidrio
- 7 Tobera

Montaje del ventilador

Prestar atención al dimensionamiento del conducto del aire. El dimensionamiento se debe realizar en base al caudal, a la temperatura del aire, en base a la distancia del ventilador del quemador y a las características del ventilador.

¡ATENCIÓN! El fuelle entregado con el equipamiento es de tela y cuenta con distanciadores de bloqueo para evitar que se rompa durante el montaje: primero montar el fuelle entre las bridas y, después, extraer los distanciadores de bloqueo.

El quemador nace para funcionar situado según la figura indicada bajo. Por instalaciones diferentes, se ruega contactar el despacho técnico.

Orientación del quemador Duo-block

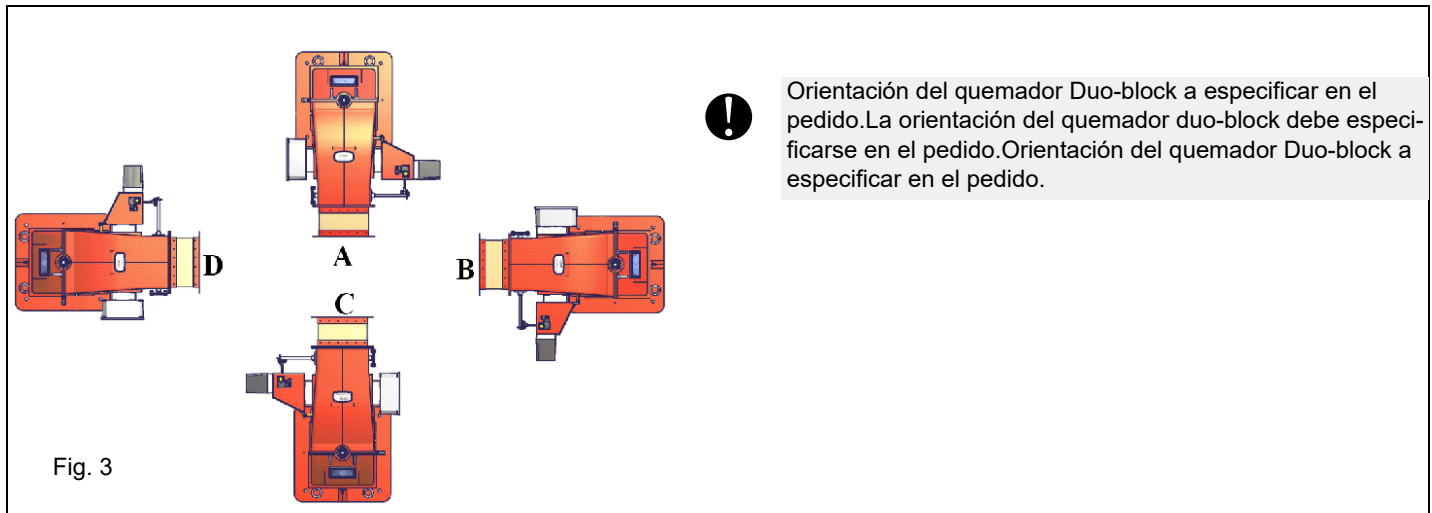

Los quemadores descritos en este manual han sido probados en cámaras de combustión que corresponden a las normativas EN676, cuyas dimensiones están descritas en el diagrama. Si el quemador debe ser acoplado a calderas con cámaras de combustión de diámetro o de longitud inferior a aquellas descritas en el diagrama, sírvase tomar contacto con el fabricante para poder controlar que sea adecuado para la aplicación prevista. Para acoplar correctamente el quemador a la caldera, verificar el tipo de tobera y controlar que la potencia necesaria y la presión en la cámara de combustión estén dentro del campo de trabajo. Si no corresponden, deberá ser evaluada nuevamente, conjuntamente con el Fabricante, la selección del quemador. Para elegir la longitud de la tobera es necesario atenerse a las instrucciones del fabricante de la caldera. En ausencia de éstas será necesario seguir las siguientes indicaciones:

Acoplamiento del quemador a la caldera

- Calderas de fundición, calderas de tres conductos de humo (con el primer conducto en la parte trasera): la tobera debe entrar en la cámara de combustión no más allá de **Dist = 100 mm**.

Calderas presurizadas de inversión de llama: en este caso la tobera deberá penetrar en la cámara de combustión por **Dm 50 ÷ 100 mm**, respecto de la placa de las tuberías.

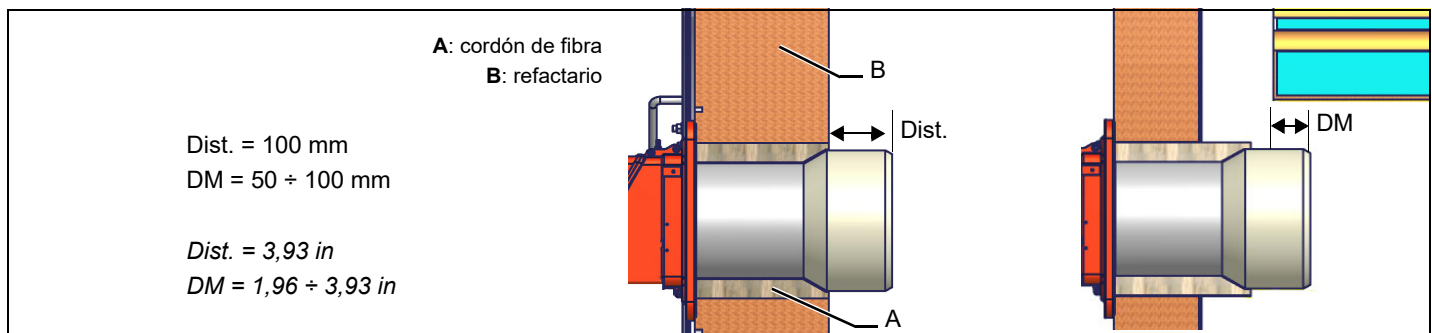

¡ATENCIÓN! Sellar el espacio entre la tobera y el material comprimido refractario, con material aislante (cordón de fibra resistente a la temperatura o cemento refractario).

La longitud de las toberas no siempre cumple con este requisito, por lo cual podría ser necesario utilizar un distanciador de medida adecuada, que sirve para alejar el quemador en modo de conseguir la medida más arriba solicitada.

Diagrama de cableado del presostato aire al conducto de aire del quemador

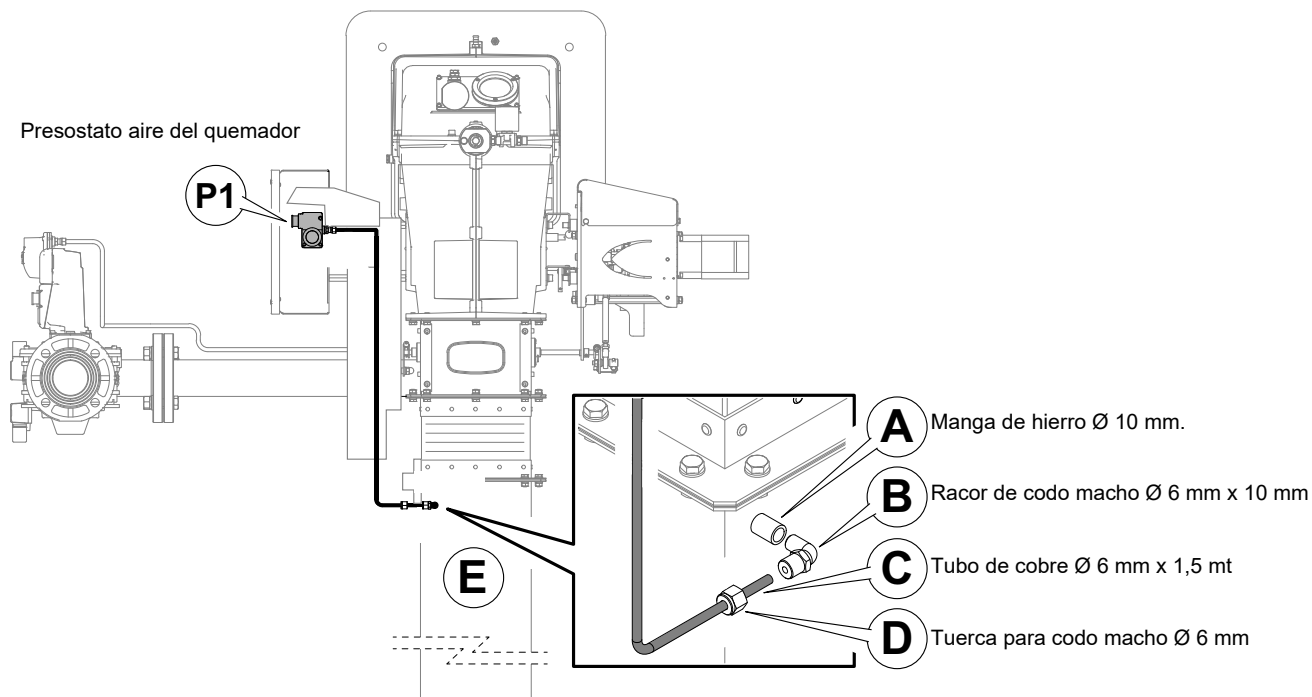

Conexión tubo de cobre Ø 6 mm:

- Perfore el conducto de aire (con un orificio de Ø 10 mm);
- Montar el manguito A (Ø 10 mm) y soldarlo en el canal E;
- Ensamble en detalle los detalles B-D en el tubo (Ø 6 mm) C de forma adecuada hasta la conexión en el presostato de aire (P1).

ESQUEMA DE INSTALACIÓN RAMPA DE GAS



ATENCIÓN: antes de ejecutar los enlaces a la red de distribución del gas, cerciorarse que las válvulas manuales de interceptación sean cerradas. ligeras cuidadosamente el capítulo "advertencias" del presente manual.



ATENCIÓN: se recomienda montar el filtro y las válvulas del gas de manera tal que durante la fase de mantenimiento y limpieza de los filtros (tanto de aquellos externos como de aquellos internos al grupo de válvulas), no caiga material extraño en el interior de las válvulas (véase capítulo "Mantenimiento").



ATENCIÓN: después de haber montado la rampa según el esquema indicado, tiene que ser efectuada la prueba de estanqueidad del circuito gas, según las modalidades previstas por la normativa vigente.



ATENCIÓN: se recomienda montar el filtro con flujo de gas paralelo al suelo, para impedir que durante las operaciones de mantenimiento caiga polvo en la válvula de seguridad después del filtro.



ATENCIÓN: Retire las tapas y cubiertas de las unidades antes de la instalación.



NOTA: La junta antivibrante, el grifo de interceptación y las juntas no hacen parte del suministro estándar

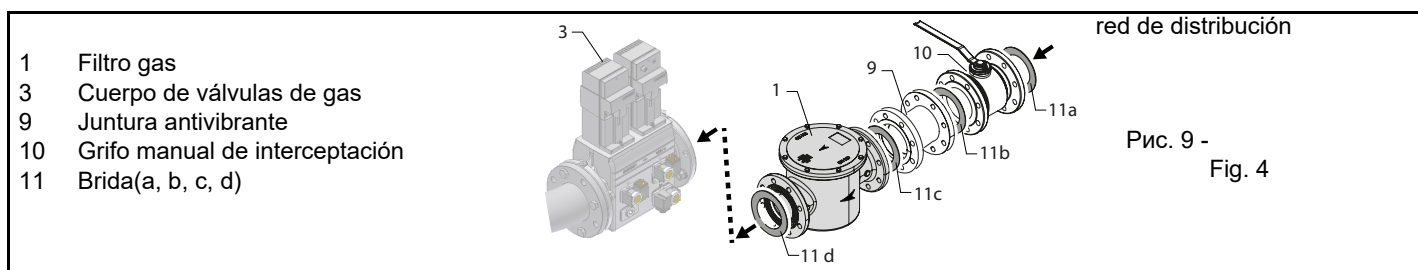

Montaje del cuerpo de válvula en la línea de gas: Se necesitan 2 bridas para montar los conjuntos de válvulas de gas.

- Las válvulas de hasta 2" se suministran con bridas roscadas especiales.
- Las válvulas de DN65 y superiores se suministran con bridas PN16.

Filtro de gas (si está previsto)

Los filtros para gas detienen las partículas de polvo del gas y protegen los elementos en peligro (por ej.: quemadores, contadores y reguladores) de una rápida obstrucción. El filtro generalmente está ubicado antes de todos los órganos de regulación e interceptación.



ATENCIÓN: se recomienda montar el filtro con flujo de gas paralelo al suelo, para impedir que durante las operaciones de mantenimiento caiga polvo en la válvula de seguridad después del filtro.

Una vez instalada la rampa de gas, realizar las conexiones eléctricas de sus componentes: grupo de válvulas, presostatos y control de estanqueidad

MultiBloc MB-DLE - Ensamblaje de la rampa del gas

Montaje

- 1 Montar la brida sobre la tuberías: utilizar oportunas guarniciones por gas
- 2 Insertar lo equipo **MB-DLE** y hacer particular caso a los O-ring
- 3 Extraer el GasMultiBloc entre las bridas roscadas
- 4 Después del montaje, controlar la estanqueidad y el funcionamiento
- 5 El desmontaje debe ser efectuado exactamente en orden inverso

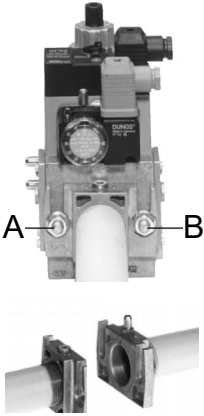
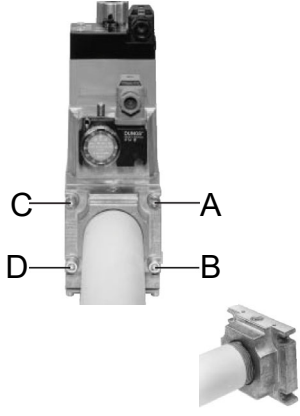
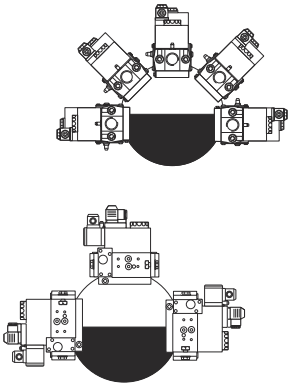
	MB-DLE 405.. 412	MB-DLE 415.. 420	POSICIÓN DE MONTAJE
 <p>(O-Ring)</p>	 <p>A B</p>	 <p>C A D B</p>	
Fig. 5	Fig. 6	Fig. 7	Fig. 8
Рис. 6 -	Рис. 7 -	Рис. 8 -	Рис. 9 -

DUNGS MBE - Componentes y posición de los presostatos

DUNGS MBE..
Posiciones de montaje

! En las versiones de equipos, Easy VD-R debe instalarse antes de la válvula

1 Presostato de gas mínimo PGMIN	5 Actuador con estabilizador de presión incorporado
2 Presostato de gas mínimo PGMIN (alternativa a 1)	6 Actuador On-Off
3 Presostato de gas de control de fugas PGCP	7 Cuerpo de la válvula (rosca)
4 Presostato de gas máximo PGMAX	8 Cuerpo de la válvula (brida)

Conexión del sensor de presión PS al actuador VD-R y a la rampa de gas

min. 5 Ø

SW 17 21/32" max. 7 Nm max. 62 lb-in

≥ 8 mm / 0.32 inch

VD-R + PS



Atención: En el caso de la válvula MBE..., es obligatorio un interruptor de límite de presión aguas abajo de la válvula de seguridad.

Tomas de presión MultiBloc MBE

125 / 6 DUNGS®

50 / 2 DUNGS®

p_{max} 70 kPa 700 mbar 10 PSI

p_{max} 60 kPa 600 mbar 8 PSI

1, 2, 3, 5 Tapón de cierre G1/8 ISO 228

4 G3/4 para los accesorios del sistema

6, 7 Tapón de cierre G1/4 ISO 228

8 Para la versión VB...L sólo: conexión para la línea de ventilación VB-2½L=1¼"NPT

1, 2, 3, 4 Tapón de cierre G1/8 ISO 228

Siemens VGD20.. e VGD40..

Componentes y posición de los presostatos

1 Presostato de gas mínimo PGMIN
 2 Presostato de gas mínimo PGMIN (alternativa a 1)
 3 Presostato de gas de control de fugas PGCP
 4 Presostato de gas máximo PGMAX
 5 Actuador con estabilizador de presión incorporado
 6 Actuador On-Off
 7 Cuerpo de la válvula (rosca)
 8 Cuerpo de la válvula (brida)

SIEMENS VGD..
Posiciones de montaje

Conexión del actuador SKP2... a la rampa de gas

min. 5 Ø

TP SA
BS D SKP2
aga25 (optional)

Válvulas gas Siemens VGD - Versión con SKP2. (con estabilizador de presión incorporado)

- Conectar el tubo de referencia de presión de gas (TP en figura - tubo dotado suelto con diámetro externo de 8 mm) en los racores apropiados, ubicados en la tubería de gas, después de las válvulas de gas: la presión del gas debe ser obtenida a una distancia igual o superior a aproximadamente 5 veces el diámetro nominal de la tubería.
- Purgar al aire libre (SA en figura). Si el resorte instalado no cumple con las exigencias de regulación, contactar con nuestros centros de asistencia para que el envío de un resorte apropiado.
- D:



ATENCIÓN: ¡Si se sacan los 4 tornillos BS, el regulador queda inutilizado!

Siemens VGD Tomas de presión

Strainer

p_i p_m p_o

1 9 3 4 5 2 11
 (G 1/4") (G 1/8") (G 1/4") (G 3/4") (G 1/8") (G 1/4") (G 1/8")
 (G 1/8") (G 1/8") (G 1/8") (G 1/8")
 7 6 8 10

V1 V2

1 2
 10 5 6 7 8 9

4 3

Leyenda
pi Presión de entrada
pm Presión entre válvulas
po Presión de salida

Rampa 1 - Rampa gas con grupo válvulas VGD20/40 con estabilizador de presión gas incorporado + control de estanqueidad

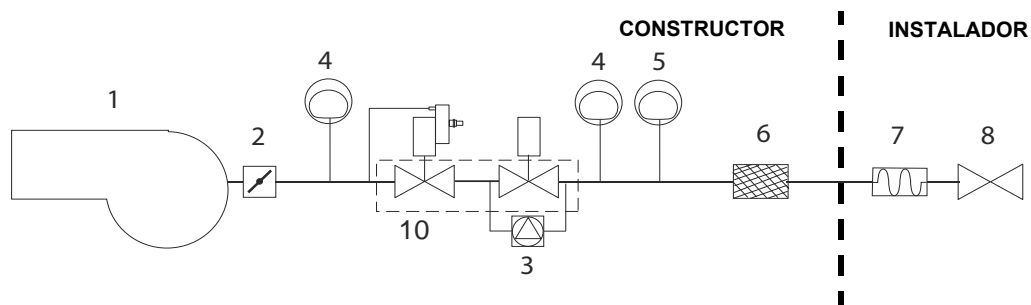

Rampa 4 - Rampa gas con grupo válvulas VGD20/40 con estabilizador de presión gas incorporado + Presostato gas control de

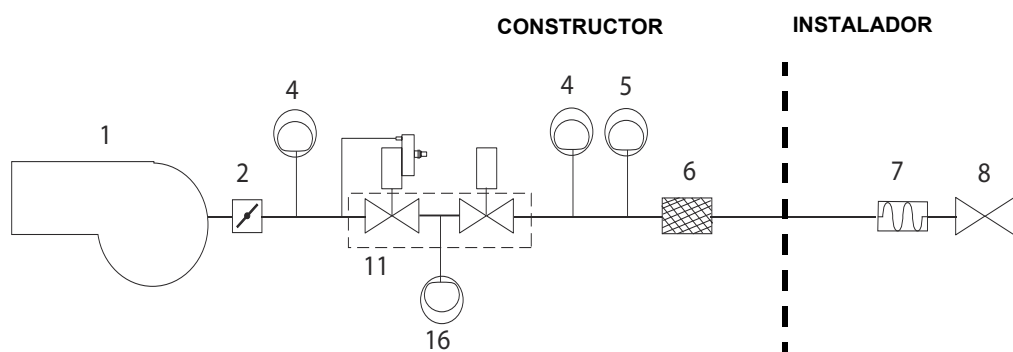

Leyenda

- | | |
|---|--|
| 1 Quemador | 6 Filtro gas |
| 2 Válvula mariposa | 7 Junta antivibrante |
| 3 Control de estanqueidad | 8 Grifo manual de interceptación |
| 4 Presostato gas de máxima presión (en opción*) | 10 Grupo válvulas VGD |
| 5 Presostato gas de mínima presión | 16 Presostato gas control de pérdidas PGCP |

Nota: el presostato de maxima puede ser montado o despues de las válvulas del gas o antes el grupo y despues de la válvula de mariposa (ves esquema - elemento 4).

QUEMADORES CON VARIANTE INVERSOR (si se suministran)



fabricante proporciona:

KOSTAL: a bordo o montado en la pared (en este último caso se requiere el kit).

DANFOSS: de pared.

Ambos pueden estar equipados con una resistencia de frenado.

La caja de bornes del quemador está preparada para recibir determinadas señales (para la conexión al inversor, véase el esquema de conexión dedicado).

Señales de entrada para el inversor en función del equipo:	
LMV51.300 / LMV52.xxx	4÷20mA
HAGC31-CU01	4÷20mA
LMV37.400 / LMV26.300	0÷10V

Los quemadores con cama electrónica **LMV51.300 / LMV52.xxx**, **HAGC31-CU01** e **LMV37.400/LMV26.300** equipados con motor de ventilador accionado por inverter, además de las curvas de regulación de aire y combustible, también tienen una curva de regulación de velocidad del motor de ventilador.

Generalmente la curva del inverter va del 50% al 100% de las revoluciones del motor. Esto no sólo mejora la regulación del quemador sino que también permite un ahorro en el consumo del motor del ventilador.

Regleta de bornes de interfaz con inverter

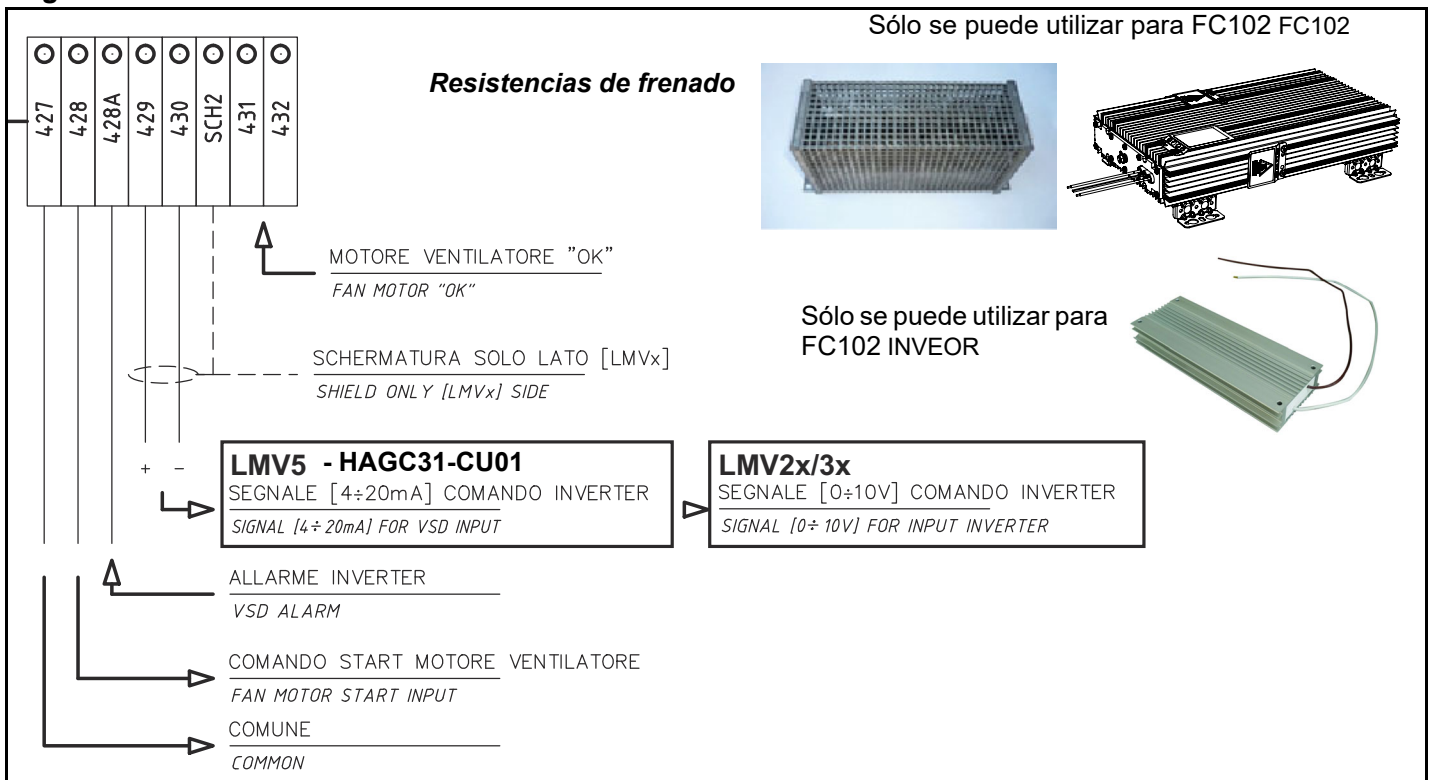

Sensor de velocidad AGG 5.310

es un kit de sensor de velocidad usado para monitorear la velocidad de un motor. Este kit se utiliza para montar el sensor de velocidad directamente en la carcasa del motor.

Fig. 9

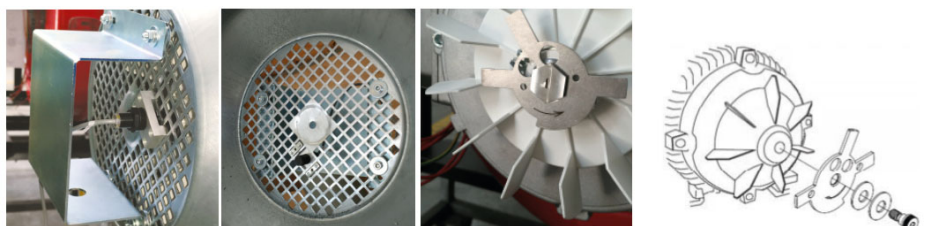

ESQUEMA DE LAS CONEXIONES ELÉCTRICAS

! *La seguridad eléctrica del equipo se obtiene cuando éste ha sido correctamente verificado por personal profesionalmente calificado*

! **ATENCIÓN :** *Está prohibido utilizar las tuberías como conexión eléctrica para la tierra*

- ⚡**
- La instalación debe ser efectuada respetando las normativas vigentes en materia y según las instrucciones del fabricante, ésta debe ser efectuada por personal profesionalmente calificado .
 - Comprobar una eficaz conexión de tierra realizada como previsto por la normativa ..
 - No utilizar las tuberías y partes metálicas como conexión para la tierra
 - Conectar el cable de la tierra en la bornera MA , de longitud como fase y neutro .
 - No invertir fase y neutro
 - Para la conexión con la red eléctrica es necesario prever un interruptor omnipolar diferencial y magnetotérmico , tal como previsto por la normativa de seguridad vigente .
 - Hacer controlar por parte de personal calificado que la instalación eléctrica sea adecuada a la potencia máxima absorbida por el equipo indicada en la placa , controlar especialmente que la sección de los cables de instalación sean del tipo idóneo con la potencia absorbida por el equipo.
 - En caso de avería y/o malfuncionamiento del equipo, desactivarlo,absteniéndose de realizar cualquier intento de reparación o de intervenir directamente .
 - Comprobar tensión y frecuencia prevista en la tarjeta del quemador
 - Comprobar la protección IP prevista en la placa del quemador
 - Antes de efectuar cualquier operación de limpieza o de mantenimiento ,desenchufar el equipo de la red de alimentación interviniendo en el interruptor del equipo y/o en los correspondientes órganos de interceptación.
 - Otras
 - Utilizar cables correctos entre el quemador y la caldera
 - Para la alimentación general del equipo de la red eléctrica no está permitido el uso de adaptadores , tomas múltiples y/o alargadores

En cualquier caso:

- Proporcionar cables de alimentación de red y de trazado de red/quemador adecuadamente protegidos y seguros, con cable eléctrico ignífugo de sección adecuada a la potencia instalada;
- Evite absolutamente el uso de alargadores, adaptadores o regletas;

⚡ **PELIGRO:** Es posible que algunos componentes sigan bajo tensión a pesar de estar desconectados de la red y puedan provocar descargas eléctricas.

PELIGRO: PELIGRO! el quemador (versiones de dos llamas) se suministra con un puente eléctrico entre los bornes 6 y 7; si debe ser conectado el termostato alta/baja llama, eliminar dicho puente antes de conectarlo.

⚡ **ATENCIÓN:** Realice las conexiones eléctricas al cuadro de bornes de la MA consultando los esquemas eléctricos adjuntos al manual. El cuadro eléctrico se suministra completo con un tablero de bornes para las conexiones a la línea eléctrica del sistema y, en el caso de un cuadro embarcado, una clavija de conexión de la sonda de modulación (si está presente).

Nota su la alimentación eléctrica

Si la alimentación eléctrica del quemador es de 230 V trifásica o 230 V fase-fase (sin neutro), con el equipo Siemens LME.. entre el borne 2 (borne X3-04-4 por LMV2x, LMV3x, LMV5x, LME7x) del soporte y el borne de tierra se deberá agregar el circuito RC Siemens, RC466890660. En el caso de quemadores equipados con LMV5x, consultar las indicaciones del cableado del sistema, suministradas por Siemens en el CD adjunto

Leyenda

- C - Condensador (22nF/250V)
- LME / LMV - Equipo Siemens control llama
- M - borne 2 (LGB,LMC,LME), borne X3-04-4 (LMV2x, LMV3x, LMV5, LME7x)
- R - Resistencia (1 MΩ)
- RC466890660 - Circuito RC Siemens

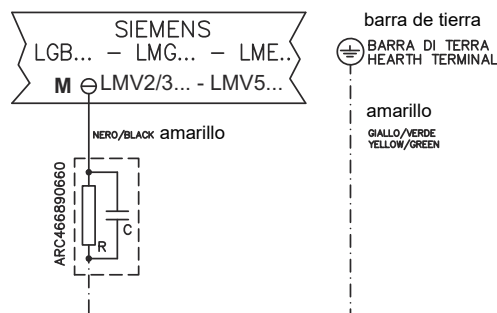





Fig. 10 -

Rotación motor

- 
ATENCIÓN: los quemadores son suministrados para alimentación trifásica 380/400/415/480 V; en caso de alimentación trifásica 220/230/240 V es necesario modificar las conexiones eléctricas entro de la bornera del motor eléctrico y sustituir el relé térmico.
- 
ATENCIÓN: controlar el calibrado del termico del motor (+ 5% +10%)
- 
PELIGRO: la rotación no correcta del motor es un peligro para las personas

Tras haber terminado la conexión eléctrica del quemador, controlar la rotación del motor eléctrico. El motor debe girar (mirando el ventilador de enfriamiento del motor) en sentido antihorario. Si está girando en sentido horario , invertir la alimentación trifasica y volver a contolar la rotación del motor.

Una vez finalizada la conexión eléctrica del quemador, no olvide comprobar la rotación del motor eléctrico tanto de la bomba (si está instalada) como del ventilador. El motor debe girar en el sentido indicado en la carcasa. En caso de rotación incorrecta, invierta la conexión de 2 de las 3 fases del cable de alimentación trifásico y vuelva a comprobar la rotación del motor.

Рис. 9 -



Curvas de presión en cabezal de combustión - caudal gas

.Las curvas presión - caudal se refieren al quemador en combustión (porcentaje de O2 residual en los humos conforme a la table "Parámetros de combustión recomendados" y CO dentro de los límites establecido por las normas), con cabezal de combustión en su máxima apertura, servomando al máximo y mariposa del gas a la máxima apertura. Véase la , la cual indica el modo correcto para medir la presión del gas, tomando en consideración los valores de contrapresión en la cámara de combustión.

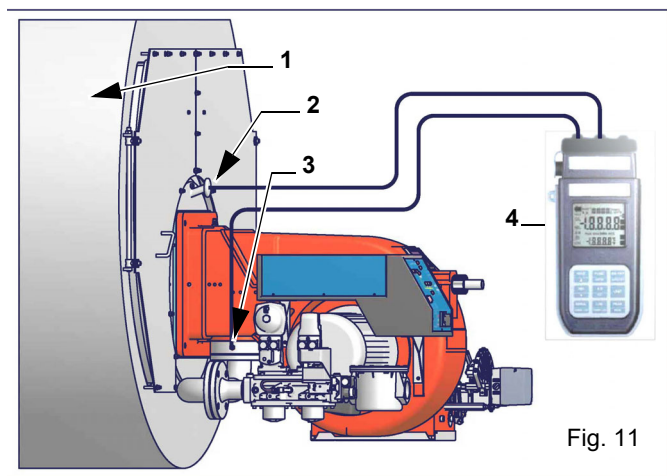

Nota: el dibujo es indicativo

Leyenda

- 1 Generador
- 2 Toma de presión cámara de combustión
- 3 Toma de presión gas válvula de mariposa
- 4 Manómetro Diferencial



NOTA: LAS CURVAS DE PRESIÓN - CAUDAL SON COMPLETAMENTE INDICATIVAS; PARA OBTENER UNA CORRECTA REGULACIÓN DEL CAUDAL DE GAS, HACER REFERENCIA A LA LECTURA DEL CONTADOR.

Medición de la presión en la cabeza de combustión

Colocar las sondas relativas en las entradas del manómetro: una en la toma de presión de la caldera para detectar el dato de presión en la cámara de combustión y la otra en la toma de presión de gas de la válvula de mariposa del quemador para detectar la presión en la cabeza de combustión. En base a la presión diferencial detectada de esta manera, se obtiene el dato relativo al caudal máximo de gas: utilizando los gráficos de las curvas de presión-caudal en la cabeza de combustión del capítulo siguiente, a partir del dato relativo a la presión en la cabeza (que se indica en la ordenada), se obtiene el valor del caudal quemado en Stm^3/h , que se indica abscisa.

Curvas de presión - caudal en cabezal de combustión (gas natural)



¡Las curvas se refieren a presión = 0 en la cámara de combustión!

PRESIÓN GAS EN CABEZAL mbar

TP90A

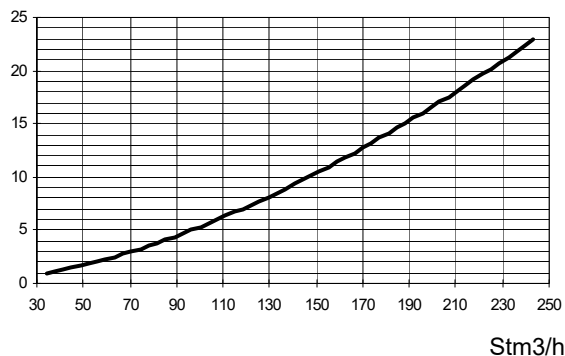

TP91A

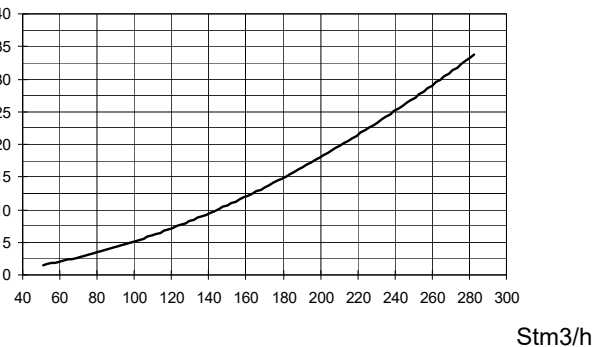

TP92A

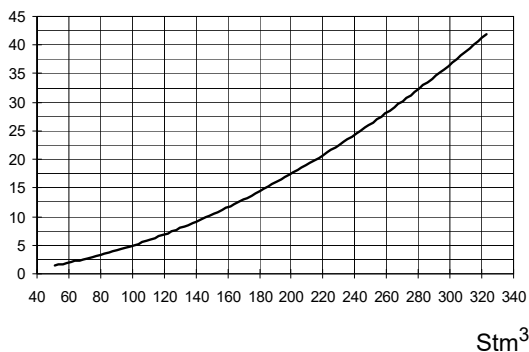

TP93A

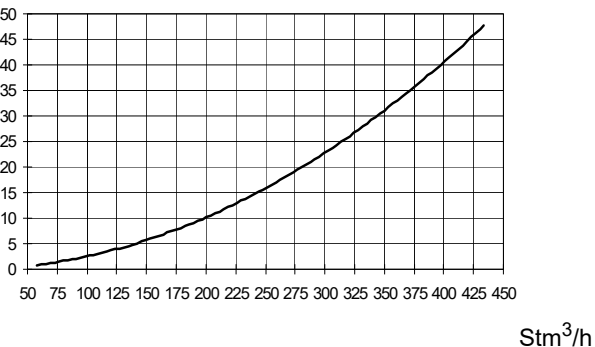

PRESIÓN GAS EN CABEZAL mbar

TP512A

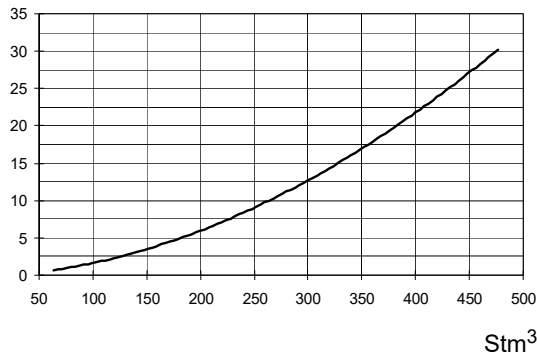

TP515A

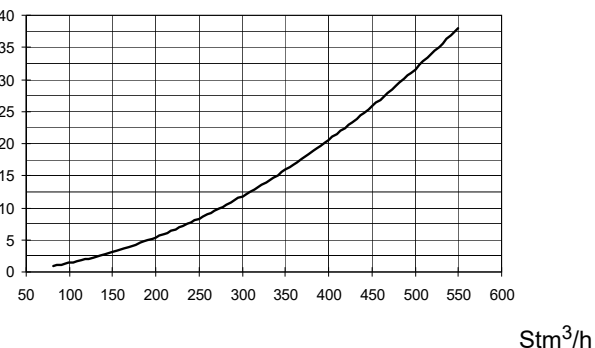

PRESIÓN GAS EN CABEZAL mbar

TP520A

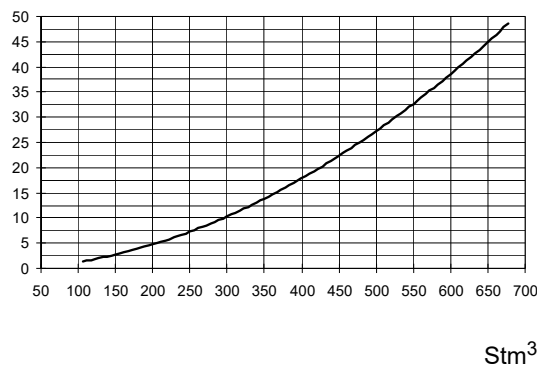

TP525A

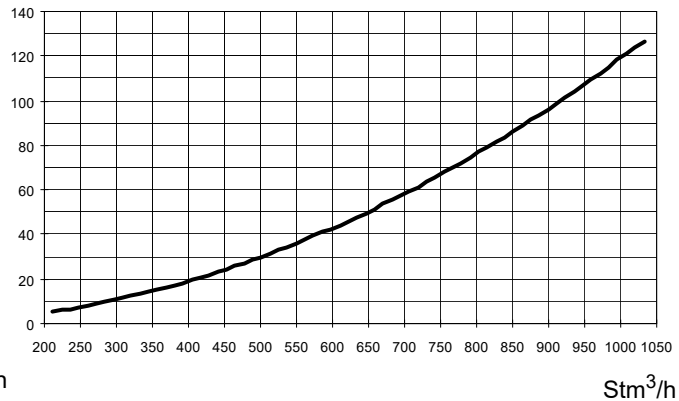

REGULACIÓN DE AIRE Y GAS

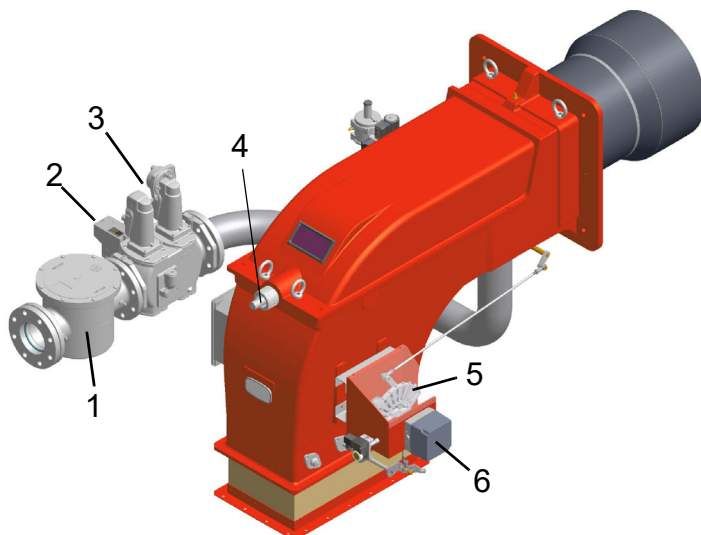

Fig. 11

Leyenda

- 1 Filtro gas
- 2 Control de estanqueidad
- 3 Válvulas gas
- 4 Tornillo regulación cabeza combustión
Tornillo de regulación cabeza de combustión
- 5 Sector variable
- 6 Servocomando

Filtro de gas

Los filtros para gas detienen las partículas de polvo del gas y protegen los elementos en peligro (por ej.: quemadores, contadores y reguladores) de una rápida obstrucción. El filtro generalmente está ubicado antes de todos los órganos de regulación e interceptación.

Control de la estanqueidad integrado (para quemadores equipados con LME7x, LMV, LDU)

A continuación se describe el funcionamiento del control de estanqueidad integrado:

- Inicialmente ambas válvulas EV1, EV2 están cerradas
- Fase de evacuación: la válvula EV2 (lado del quemador) se abre y se mantiene en esta posición durante un periodo de tiempo td_4 , con el fin de llevar el volumen de prueba (espacio entre EV1 y EV2) a la presión atmosférica. Fase de evacuación: la válvula EV2 (lado quemador) es abierta y mantenida en esta posición por un periodo de tiempo td_4 , de manera tal de llevar el volumen de prueba (espacio entre EV1 y EV2) a la presión atmosférica. Prueba de la presión atmosférica: la válvula EV2 es cerrada y mantenida en esta posición por un periodo de tiempo td_1 . El presostato PGCP no debe detectar un aumento de presión.
- Fase de llenado: la válvula EV1 es abierta y mantenida en esta posición por un tiempo td_3 de manera tal de permitir el llenado del volumen de prueba
- Prueba de la presión del gas: la válvula EV1 es cerrada y mantenida en esta posición por un tiempo td_2 . El presostato PGCP no debe detectar una disminución de presión.

Si todas las fases antes enumeradas son realizadas con éxito, la prueba de estanqueidad puede considerarse concluida de forma positiva. De lo contrario, se producirá un bloqueo del quemador. Para LMV5x, LMV2x/3x y LME73 (excepto para LME73.831BC), el control de estanqueidad puede ser configurado de modo que se produzca en el encendido, apagado o ambos.

Para LME73.831BC el control de estanqueidad es configurado exclusivamente para que se realice en el encendido.



Рис. 7 -

Regulación caudal aire y gas

¡IMPORTANTE! el exceso de aire de combustión se debe regular según los parámetros recomendados, reproducidos en la siguiente tabla:

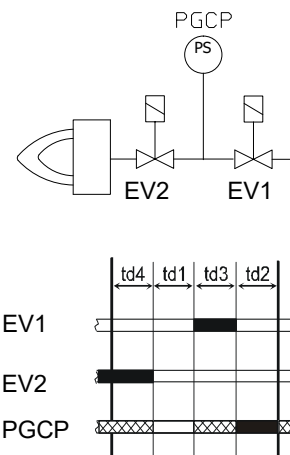

PELIGRO Al ajustar la relación aire/combustible, es obligatorio utilizar un analizador de gases de combustión adecuado, calibrado y comprobado según la norma, para comprobar constantemente el exceso de aire correcto. El incumplimiento de esta recomendación puede conllevar graves peligros.

PELIGRO! Durante las operaciones de calibración prestar atención para no hacer funcionar el quemador con caudal de aire insuficiente (peligro de formación de monóxido de carbono); si esto sucediera reducir lentamente el combustible hasta lograr los valores de combustión normales.

¡IMPORTANTE! el exceso de aire de combustión se debe regular según los parámetros recomendados, reproducidos en la siguiente tabla:



PELIGRO ! Purgar el aire y las impuridades de la tubería del gas con seguridad , para evitar concentración de gas del local caldera. Las apertura de aireación del local caldera tengas dimensiones requeridas a fin de garantizar el vaciado de los gases ,Antes de poner el quemador en marcha ,comprobar la salida de los gases ,a fin de garantizar el vaciado de los gas del local caldera .

Parámetros de combustión recomendados		
Combustible	CO ₂ Recomendado (%)	O ₂ Recomendado (%)
Gas natural	9 ÷ 10	3 ÷ 4.8

Durante el ensayo en fábrica, la posición de la mariposa del gas, las compuertas de aire en llama baja y la regulación del servomando se establecen sus valores medios.

Regulación – descripción general

La regulación de los caudales de aire y de combustión se realiza antes de alcanzar la potencia máxima (“llama alta”), interviniendo respectivamente en el registro de aire y en el sector variable.

- Comprobar que los parámetros de combustión se encuentren dentro de los límites recomendados.
- Comprobar el caudal midiéndolo en el contador o, si no fuera posible, comprobando la presión en la cabeza de combustión con un manómetro diferencial, como se describe en el apartado “Medición de la presión en la cabeza de combustión”
- Siguiendo el procedimiento de ajuste de las curvas relación aire/combustible reparadas en el manual del controlador LMV, proceder con la regulación de aire y gas.
- Por último, establecer la potencia de la llama baja par evitar que la potencia en llama baja sea demasiado alta, o bien que la temperatura de los humos sea demasiado baja y produzca la formación de condensaciones en la chimenea.
-

Procedimiento de regulación

Reglaje de quemador

El usuario puede cambiar solo el parametro del set point sin haber un código para entrar

El manejo la programación del sistema de gestión de quemadores tienen lugar mediante la unidad de indicación y manejo (AZL 5) o mediante la herramienta del PC. La unidad de indicación y manejo con monitor de texto LCD una guía de usuario mediante menú, permite un manejo sencillo y un diagnóstico selectivo



El usuario puede en el display :

- 1 - se muestran en el display los estados de funcionamiento , el tipo de error y cuando se ha producido
- 2 ESC (último dígito) puede editarse el último dígito pulsando la tecla ESC
- 3 ENTER (nivel siguiente) en caso de que se debe introducir una contraseña, se marca la línea Enter password mediante decremento(el cursor se encuentra también en la primera posición de esta línea) y confirmar la nueva selección.
- 4 SELECT para seleccionar en el menú y cambiar los parámetros

Se puede comprobar en el manual LMV

Durante el desplazamiento manual , los accionamientos recorren las rectas interpolada hasta la posición de ajuste máxima de 90 ° de los actuadores al 100% de la potencia. Es preciso comprobar continuamente los valores de gas de escapey la estabilidad de la llama.Puede que sea necesario definir puntos de curva provisionale que pueden borrarse mas adelante.realizar las regulaciones de aire y gas: monitoreando constantemente el análisis de los humos, para evitar escasas combustiones de aire, dosificar el aire en base a la variación del caudal del gas realizada según el procedimiento descrito a continuación;

Regular el **caudal del gas con llama alta** a los valores requeridos por la caldera/usuario, interviniendo en el estabilizador de presión del grupo

Puesta en marcha

- 1 Seleccionar quemador en marcha
- 2 the LMV comienza el ciclo de arranque de el quemador , en el display AZL aparece System Test message al final de el test ; con la cadena termostatica abierta aparece stand by programa 12

Setpoint	80°C
Act.value	78°C
Fuel	
Standby	12

Pagina menú

- 3 comprobar rotación motor (relativa description)
- 4 comprobar la linea termostatica de seguridad para el arranche del quemador
- 5 comienza el ciclo de arraque y aparece programa no. 12

- **Tiempo de preventilación** no. 30
- **Desplazamiento a posición de encendido** no. 36
- **Tiempo de encendido** no. 38
- **Combustible** (los válvulas de combustible abre)
- **Primer tiempo de seguridad**
- **El quemador se pone in llama mínima**

Una vez que el ciclo de encendido es terminado aparece:

Setpoint	80°C
Act.value	78°C
Load	24%
Flame	60%

- Set point:** temperatura de set point
 - Act value:** valor actual de temperatura
 - Load:** porcentaje de carga(capacidad de quemador)
 - Flame:** porcentaje de valor de ionización
- empuje ENTER aparece in el display

Fuel	0.0	Air	1.8
Ax		VSD	0.0
Ax		O2	
Ax		Ld.	0.0

- Fuel:Combustible:** grados de la posición del servomando combustible
- Aire:** grados de la posición del servomando aire

Ax1..3: auxiliares

VSD: % de el valor the inverter a la máxima frecuencia

O2: porcentaje de oxigeno

Ld: porcentaje de carga(capacidad de quemador)

Empuje ENTER para retornar a la pagina principal.

Para entrar en la pagina menú , de pagina principal ,empuje ESC dos veces.

OperationalStat
Operation
ManualOperation
Params & Display

Pagina menú

Empuje una ves ESC aparece Estado Operacional in en display

Normal operation
Status/Reset
Fault History
Lockout History

in el menú Estado Operacional se puede ver

- Empuje ENTER para seleccionar Normal operación.aparece la pagina principal; empuje ESC para retornar a el menú principal
- Estado /rearme aparece error y fallos / function de rearme
- Historia de fallos: empuje ENTER ,aparece los ultimos 21 fallos
- Historia de fallos: empuje enter , aparece la historia de los ultimos 9 fallos con data y hora .
- Alarma / desactivar: activar / desconetar en caso de alarma

Historia de fallos

Empuje ENTER ,aparece esto mensaje

1 Class:			05Gas
code	BF	Phase:	10
Diag.:	00	Lod:	0.0
Start No.			88

aparece despues el fallos esto mensaje :

O2 control and limiter automat deactivated
--

Para ver los otros fallos empuje la flecha

Para salir de esta historia de fallos empuje ESC

Historia de fallos

Para ver la historia de fallos empuje ENTER , aparece esto mensaje

1	10.08.07		13.47
C:71	D:00	F:	12
Start No.			88
Load	0.0		Gas

aparece despues el fallos esto mensaje

No flame at end
of safety time

Para ver los otros fallos empuje la flecha

Para salir de esta historia de fallos empuje ESC

Regulacion de la temperatura / presión con el set point

De la pagina principal entrar in pagina menú, empujar ESC sos veces.

OperationalStat
Operation
ManualOperation
Params & Display

Con la flecha seleccionar Params%Dislpay empuje ENTER, el sistema necesita las password

Access w-out PW
Access Serv
Access OEM
Access LS

con la flecha seleccionar Access- w- out -pass (para entrar sin password) confirmar y empuje ENTER

Los otros niveles necesita la password reservado al Servicio Tecnico del fabricante.

En el menú sin password aparece.

BurnerControl
RatioControl
O2Contr./Guard.
LoadController

Seleccionar " Load Controller " y empuje ENTER , aparece :

ControllerParam
Configuration
Adaption
SW Version

Seleccionar "ControllerParam" y empuje ENTER , aparece :

ContrlParamList
MinActuatorStep
SW_FilterTmeCon
SetPointW1

Seleccionar "SetPoint W1" y empuje ENTER , aparece :

SetpointW1
Curr: 90°
New: 90°

Curr: aparece el valor de set- point , utilizar la flecha para cambiar

NOTA : el rango de estos parametros depende de la sonda instalada , la unidad de medida es el valor the limite que se puede seleccionar Nivel Servicio tecnico.

Con el nuevo set point empuje ENTER para confirmar , para salir sin hacer el cambio empuje ESC

Empuje ESC para salir del programa set - point

Una ves que el st point es seleccionado , empuje Switch - on (SDon) y Switch. off (SDoff) punto 2 de la posición de el controlador

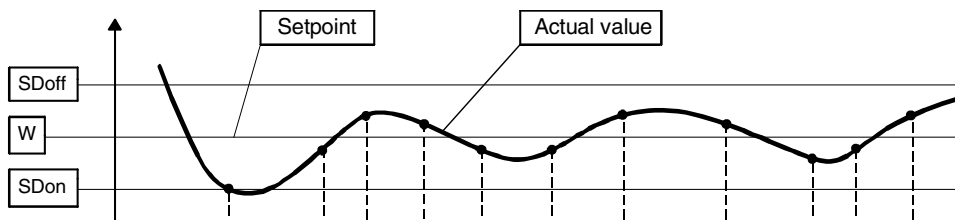

Para regular esto valor , seleccionar SD ModOn (SDOn) , avanzar a bajo con la flecha el menú de Load controller y empuje ENTER

SetpointW1
SetpointW2
SD_ModOn
SD_ModOff

in el display aparece

SD_ModOn	
Curr::	1.0%
New:	1.0%

El diferente valor para esto parametro es 1% , el quemador arranca con una temperatura mas baja de 1%de el det point

Para cambiar el valor , si es necesario , con la flecha , empuje ENTER para confirmar y empuje ESC para salir .

Para salir sin cambiar empuje ESC .

Para cambiar SD ModOFF siempre avanzar a bajo el menú de Load Controller , con la flecha , empuje ENTER.

SetpointW1
SetpointW2
SD_ModOn
SD_ModOff

in el display aparece

SD_ModOff	
Curr	10.0%
New:	10.0%

El diferente valor para esto parametro es 1% , el quemador arranca con una temperatura mas alta de 1%de el det point

Para cambiar el valor , si es necesario , con la flecha , empuje ENTER para confirmar y empuje ESC para salir .

Para salir sin cambiar empuje ESC. Empuje ESC en el menú aparece

BurnerControl
RatioControl
O2Contr./Guard.
LoadController

avanzar en el menú hasta AZL

LoadController
AZL
Actuators
VSD Module

Para confirmar empuje ENTER

Times
Languages
DateFormat
PhysicalUnits

Tiempo para seleccionar Verano (Summer) (SUM) tiempo invierno Winter (WIN) tiempo en EU Europe US United States

Sum/Winter Time
Time EU/US

Seleccionar el modo verano / invierno (Summertime / Wintertime) y empuje ENTER para confirmar , empuje ESC para salir .Seleccionar el tiempo según el país

Language: Para seleccionar el idioma:

Language	
Curr::	Italiano
New:	English

seleccionar el idioma y empuje ENTER para confirmar , para salir empuje ESC.

Dateformat: Para seleccionar data con DD . MM- YY (día- mes - ano) or MM -DD -YY (mes - día -ano)

DateFormat	
Curr::	DD-MM-YY
New:	MM-DD-YY

seleccionar el modo y empuje ENTER para confirmar , para salir empuje ESC.

Unidad física: regular la temperatura/presión

UnitTemperature
UnitPressure

Regular la temperatura en ° C o ° F

Regular la presión bar o psi

- seleccionar y empuje ENTER para confirmar
- seleccionar temperatura o presión y empuje ENTER para confirmar, empuje ESC para salir

Fallos

Con el fallos aparece:

1	10.08.07	13.47
C:71	D:00	F: 12
Start No.		88
Load	0.0	Gas

llamada al Servicio Técnico

Arranche reducido con caldera fría (CSTP)

Para haber un arranque reducido con caldera fría CSTP (Cold - start thermal Schok) se puede activar esta función. El Servicio Técnico puede activar esta función. Cuando esta función esta activada , aparece esto mensaje. Cuando esta función es desactivada el quemador después el arranque ,aumenta hasta la máxima potencia.

Opeacion manual

Para excluir esta función y aumente el caudal del quemador hasta la máxima potencia proceder: Seleccionar el sistema manual (Manual Operation) con la flecha SELECT.

OperationalStat
Operation
ManualOperation
Params & Display

Seleccionar esto:

SetLoad
Autom/Manual/Off

SetLoad: regular el portentage.

SetLoad	
Curr::	0.0%
New:	20.0%

para confirmar empuje ENTER , empuje ESC para salir; seleccionar Automático / Manual/ Off.

SetLoad
Autom/Manual/Off

Autom/Manual/Off	
Curr::	Automatic
New:	Burner On

se puede hacer en 3 maneras

- Automatic:** Automático : operación automática
- Burner on:** Quemador en marcha : operación manual
- Burner off:** Quemador parado : quemador en paro

Con el quemador en marcha , el modulador de el sistema esta excluido , se hace las operaciones manuales.



Atencion: cuando el quemador esta en " quemador parado " , el quemador es en paro
Atencion: cuando el quemador es "quemador en marcha" solo el Servicio Tecnico puede regular

Para otras informaciones esta el manual de LMV 5x

Procedimiento de regulaci3n



ADVERTENCIA: hacer estas operaciones solamente una vez apagado el quemador y dejarlo enfriar.

El quemador es regulado en la f3brica con los agujeros del disco pinchado D completamente abiertos, y con la cabeza en posici3n de MAX, por lo tanto con funcionamiento a la m3xima potencia.

Para regular, solo si necesario, el flujo de gas, cerrar parcialmente los agujeros del disco pinchado, siguiendo el procedimiento indicado bajo:

- 1 aflojar los tres tornillos **V** que fijan el disco pinchado **D**
- 2 utilizando un desarmador en las entalladuras de regulaci3n del disco pinchado, girarlo en sentido horario/antihorario de manera que se abran o se cierren los orificios;
- 3 Terminada la regulaci3n, fijar los tornillos **V**.

● TP91A - TP92A - TP93A

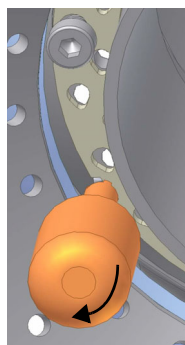
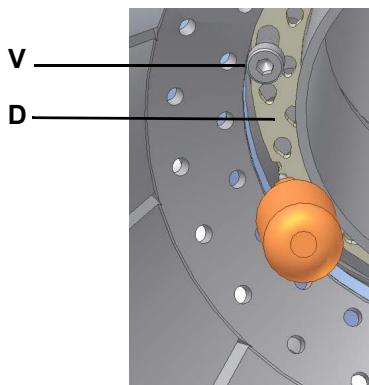

orificios abiertas

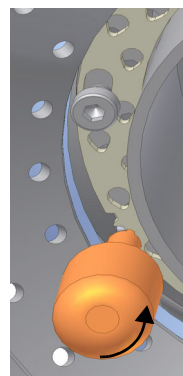

orificios cerrados

● TP512A - TP515A - TP520A - TP525A

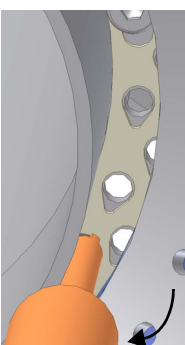
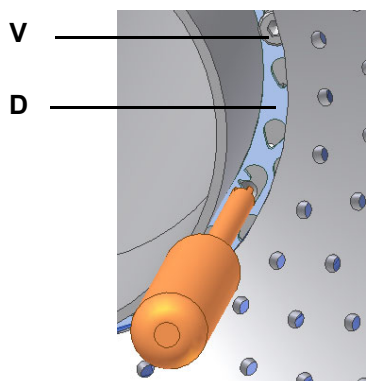

orificios abiertas

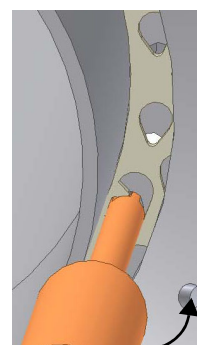

orificios cerrados

El quemador es regulado en f3brica con la cabeza en posici3n "M3X.", correspondientes a la potencia m3xima. Para el funcionamiento con potencia reducida, aflojar el tornillo VB y hacer retroceder progresivamente la cabeza de combusti3n hacia el "M3N", girando en sentido de las agujas del reloj la tuerca VRT. Una vez terminada la regulaci3n, bloquear el tornillo VB. Adjusting the combustion head. R3glage de la t3te de combusti3n. Регулировка головы сгорания. Ajuste de la cabeza. Regolazione della testa

Regulación de la cabeza de combustión

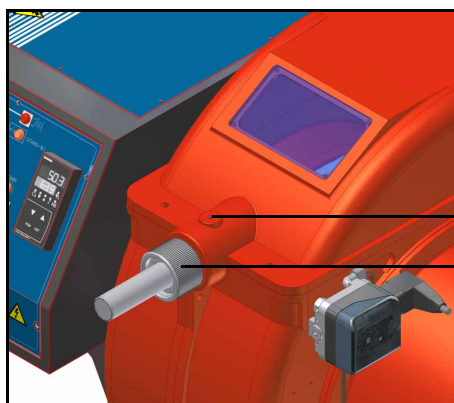

VB

VRT

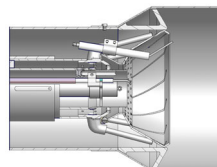

Posición de la cabeza
"MÁX"

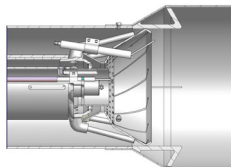

Posición de la cabeza
"MIN"

Atención: Regular la cabeza de combustión solo si necesario. Si se modifica la posición de la cabeza, repetir las regulaciones de aire y gas descritas en los puntos anteriores.

Realizar la regulación en base al servocomando suministrado.

REGULACIONES DEL GRUPO VALVULAS

MultiBloc MBE Regulación VD-R con PS



Atención: compruebe que el rango de la muela instalada sea compatible con la presión del gas en la cabeza del quemador (véase el diagrama correspondiente) a la que hay que añadir la contrapresión y unos 5 /10 mbar para pérdidas diversas y gas condensado.



Al ajustar la presión de salida, no se deben alcanzar ni exceder las condiciones de operación de peligro.

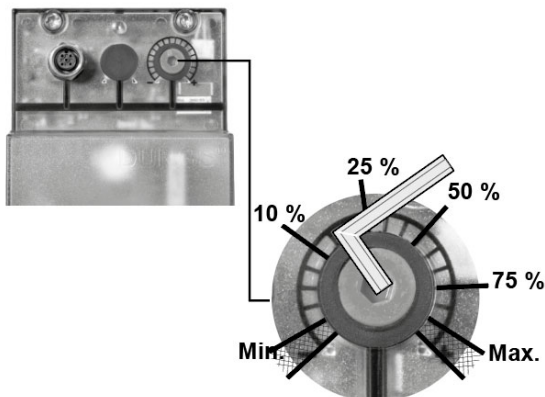

Presión de salida	MIN	10%	25%	50%	75%	MAX
PS-10/40	4 mbar 0,4 kPa 2 "w.c.	10 mbar 1,0 kPa 4 "w.c.	25 mbar 2,5 kPa 10 "w.c.	50 mbar 5,0 kPa 20 "w.c.	75 mbar 7,5 kPa 30 "w.c.	100 mbar 10,0 kPa 40 "w.c.
PS-50/200	20 mbar 2,0 kPa 8 "w.c.	50 mbar 5,0 kPa 20 "w.c.	125 mbar 12,5 kPa 50 "w.c.	250 mbar 25,0 kPa 100 "w.c.	375 mbar 37,5 kPa 150 "w.c.	500 mbar 50,0 kPa 200 "w.c.

Para ajustar la presión de salida del regulador VD-R, gire el anillo de ajuste.

La posición del indicador en el dial indica el valor de la presión de salida calculado como porcentaje del fondo de escala del sensor PS.

Siemens VGD../VRD.. con SKP

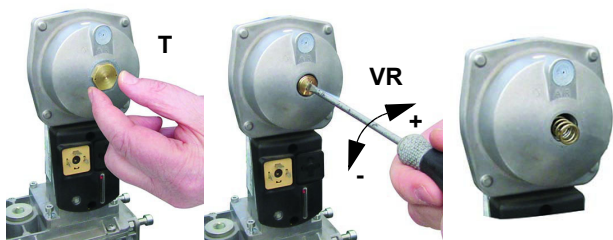

	Campos de aplicación (mbar)		
	neutral	amarilla	roja
Color resorte SKP 25.0	0 ÷ 22	15 ÷ 120	100 ÷ 250
Color resorte SKP 25.4		7 ÷ 700	150 ÷ 1500

El campo de regulación de la presión, después del grupo de válvulas, varía según el tipo de resorte suministrado con el grupo de válvulas.

Para reemplazar el muelle suministrado con el grupo de válvulas, haga lo siguiente:

Para aumentare o disminuir la presión -y de consecuencia el caudal del gas-, intervenir con un destornillador en el tornillo de regulación VR tras haber sacado el tapón T. Atornillando el caudal aumenta, destornillando disminuye.

SKP25.0

Default pressure setting

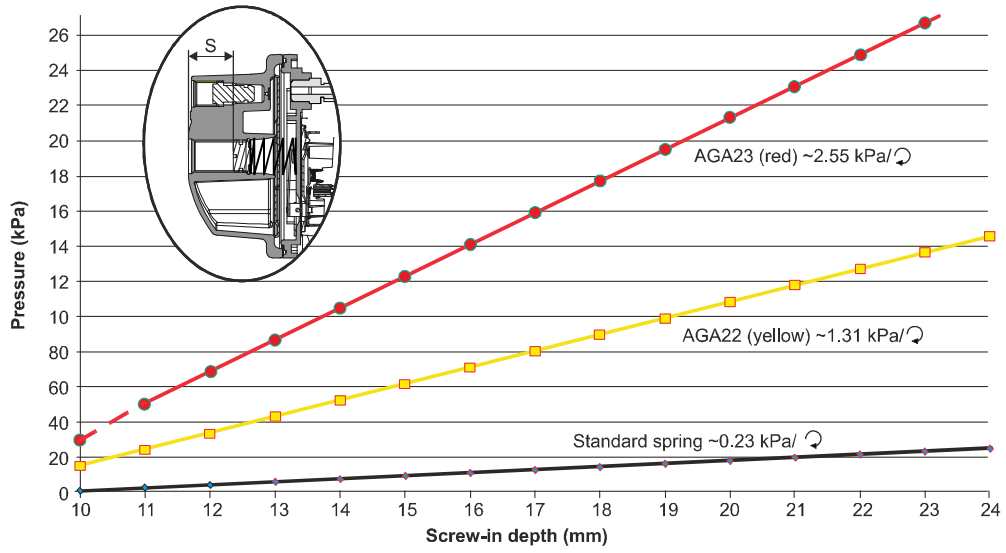

Calibración de los presostatos de aire y de gas

El **presostato de aire** cumple la función de poner en condiciones seguras (bloquear) el equipo de control de la llama si la presión del aire no es la prevista. En caso de bloqueo, desbloquear el quemador sirviéndose del botón de desbloqueo del equipo, presente en el panel de control del quemador.

Los **presostatos de gas** controlan la presión para impedir el funcionamiento del quemador en casos en los que el valor de presión no está comprendido dentro del campo de presión admisible.



Calibración presostato aire

Realizar la calibración del presostato de aire como se describe a continuación:

- Quitar la tapa de plástico transparente.
- Después de haber completado las calibraciones de aire y gas, encender el quemador.
- Con el quemador en posición de llama baja, girar lentamente la abrazadera de regulación **VR** hacia la derecha (para aumentar la presión de calibración) hasta lograr el bloqueo del quemador, leer el valor de presión en la escala y volver a configurarlo a un valor inferior a aproximadamente 15%.
- Repetir el ciclo de encendido del quemador y controlar que funcione correctamente.
- Volver a montar la tapa transparente en el presostato.

Calibración presostato gas de mínima

Con el quemador funcionando a máxima potencia, aumentar la presión de regulación girando lentamente el mando de control en el sentido de las agujas del reloj hasta que el quemador se pare, teniendo cuidado de que no entre en bloqueo y la pantalla muestre el error "Err c20 d0".

Para la calibración del presostato de gas proceder de la siguiente manera:

- Asegurarse de que el filtro esté limpio.
- Quitar la tapa de plástico transparente.
- Con el quemador en funcionamiento al caudal máximo, medir la presión del gas en la toma de presión del presostato.
- Cerrar lentamente la válvula manual de interceptación antes del presostato (véase el diagrama de instalación de rampas de gas), hasta detectar una reducción de la presión del 50% respecto al valor leído anteriormente. Controlar que no aumente el valor de CO en los humos: si el valor de CO es superior a los límites establecidos por la ley, abrir lentamente la válvula de interceptación hasta lograr los límites mencionados.
- Comprobar que el quemador funcione correctamente.
- Girar la rueda de regulación del presostato hacia la derecha (para aumentar la presión), hasta que el quemador se apague.
- Abrir completamente la válvula manual de interceptación
- Volver a montar la tapa transparente.

Calibración del presostato de gas de máxima (si estuviera presente)

Para la calibración proceder de la siguiente manera, según la posición de montaje del presostato de máxima:

- quitar la tapa de plástico transparente del presostato.
- si el presostato de máxima está montado antes de las válvulas del gas: medir la presión del gas en red con llama apagada; configurar, en la tuerca de regulación **VR**, el valor leído aumentado un 30%.
- En cambio, si el presostato de máxima está montado después del grupo "regulador-válvulas del gas" y antes de la válvula de mariposa: encender el quemador, regularlo según el procedimiento descrito en los apartados anteriores. Luego, medir la presión del gas al caudal de funcionamiento, después del grupo "regulador-válvulas del gas" y antes de la válvula de mariposa; configurar, en el tornillo de regulación **VR**, el valor leído aumentado un 30%.
- volver a montar la tapa de plástico transparente.

Presostato gas control de pérdidas PGCP (con equipo de control Siemens LDU / LME7x/Siemens LMV)

- Quitar la tapa de plástico transparente en el presostato.
- Regular el presostato PGCP al mismo valor configurado para el presostato gas de presión mínima.
- Volver a montar la tapa de plástico transparente.

PARTE II: MANUAL DE USO

LIMITACIONES DE USO

EL QUEMADOR ES UN APARATO PROYECTADO Y FABRICADO PARA FUNCIONAR SÓLO TRAS HABER SIDO ACOPLADO CORRECTAMENTE CON UN GENERADOR DE CALOR (EJ. CALDERA, GENERADOR DE AIRE CALIENTE, HORNO, ETC.), CUALQUIER OTRO USO DEBE SER CONSIDERADO IMPROPIO, POR LO TANTO PELIGROSO.

EL USUARIO DEBE GARANTIZAR QUE EL EQUIPO SERÁ MONTADO CORRECTAMENTE ENCARGANDO SU INSTALACIÓN A PERSONAL CUALIFICADO; ADEMÁS, EL PRIMER ENCENDIDO DEBERÁ SER REALIZADO POR UN CENTRO DE ASISTENCIA AUTORIZADO POR LA EMPRESA FABRICANTE DEL QUEMADOR.

SON FUNDAMENTALES EN TAL SENTIDO LAS CONEXIONES ELÉCTRICAS CON LOS ÓRGANOS DE REGULACIÓN Y SEGURIDAD DEL GENERADOR (THERMOSTATOS DE TRABAJO, SEGURIDAD, ETC.) QUE GARANTIZAN UN FUNCIONAMIENTO DEL QUEMADOR CORRECTO Y SEGURO.

POR DICHO MOTIVO DEBE SER EXCLUIDA CUALQUIER FORMA DE FUNCIONAMIENTO DEL EQUIPO QUE PRESCINDA DE LAS OPERACIONES DE INSTALACIÓN O QUE SE REALICE DESPUÉS DE TOTAL O PARCIAL MANIPULACIÓN DE ÉSTAS (EJ. DESCONEXIÓN AUNQUE PARCIALMENTE DE LOS CONDUCTORES ELÉCTRICOS, APERTURA DE LA PUERTA DEL GENERADOR, DESMONTAJE DE PARTES DEL QUEMADOR).

NO ABRIR O DESMONTAR JAMÁS COMPONENTES DE LA MÁQUINA.

UTILIZAR SÓLO EL INTERRUPTOR GENERAL, QUE DEBIDO A SU FÁCIL ACCESIBILIDAD Y RAPIDEZ DE MANIOBRA SIRVE TAMBIÉN COMO INTERRUPTOR DE EMERGENCIA Y, EVENTUALMENTE, CON EL PULSADOR DE DESBLOQUEO.

SI LA PARADA DE BLOQUEO SE REPITE, NO INSISTIR CON EL PULSADOR DE DESBLOQUEO; DIRIGIRSE A PERSONAL CUALIFICADO QUE SE ENCARGARÁ DE ELIMINAR EL MALFUNCIONAMIENTO.

ATENCIÓN: DURANTE EL FUNCIONAMIENTO NORMAL LAS PARTES DEL QUEMADOR MÁS CERCANAS AL GENERADOR (BRIDA DE ACOPLAMIENTO) ESTÁN SUJETAS A RECALENTAMIENTO. NO TOCARLAS, PARA EVITAR QUEMADURAS.

FUNCIONAMIENTO



ATENCIÓN: antes de poner en funcionamiento el quemador, asegurarse de que las válvulas manuales de intercepción estén abiertas. Asegurarse, además, de que el interruptor general de alimentación esté cerrado. Leer estrictamente las ADVERTENCIAS reproducidas en el presente manual.

- 1 Poner en posición "ON" el interruptor A presiente sobre el panel sinóptico del quemador.
 - 2 Controlar que el equipo no esté bloqueado (indicador **B** encendido), eventualmente desbloquearlo interviniendo en el botón **C** (reset-por ulteriores informaciones sobre el equipo, consultar el apéndice del manual).
 - 3 Comprobar que la serie de termostatos (o presostatos) dé la autorización de funcionamiento del quemador.
 - 4 Comprobar que la presión de alimentación del gas sea suficiente (señalada por el encendido del indicador **E**).
- Inicia el ciclo de control del dispositivo control de estanqueidad de las válvulas de gas, el control realizado es señalado por el encendido del indicador específico en el control de estanqueidad.
- 6 Arranca el motor del ventilador y comienza la fase de preventilación, el servomando alcanza la posición de máxima apertura (indicador **G** encendido); comienza el conteo del tiempo de preventilación.
 - 7 Una vez terminado el tiempo de preventilación, el servomando alcanza la posición de cierre completo (posición de encendido- 5°) y, apenas se alcanza, se activa el transformador de encendido (señalado por el indicador **I** en el panel gráfico); son alimentadas las dos válvulas gas **EV1** y **EV2** (LED **M** y **L** sobre el panel frontal).
 - 8 La llama debe formar el dentro de poco segundo de la abertura de las válvulas gas, de otro modo el equipo de control llama va en bloque. Pocos segundos después la apertura de las válvulas del gas, el transformador de encendido es excluido del circuito y el indicador **I** se apaga. De esta manera el quemador se enciende, simultáneamente el servomando alcanza la posición de llama alta (90°)
 - 9 Pocos segundos después la apertura de las válvulas del gas, comienza el funcionamiento automático: el quemador adquiere automáticamente, según lo requiera la instalación, la posición de llama alta o llama baja (quemadores progresivos - PR) o en la posición solicitada por el regulador modulante (sólo quemadores modulanti - MD).

PARTE III: MANTENIMIENTO

Al menos una vez al año realizar las operaciones de mantenimiento indicadas seguidamente. Si el servicio de mantenimiento se realiza en cada estación, es aconsejable efectuarlo a fines de cada invierno; si el servicio es de tipo continuativo, mantenimiento debe ser realizado cada 6 meses.



ATENCIÓN ¡TODAS LAS INTERVENCIONES EN EL QUEMADOR DEBEN SER REALIZADAS CON EL INTERRUPTOR ELÉCTRICO GENERAL ABIERTO Y VÁLVULAS MANUALES DE INTERCEPTACIÓN DE LOS COMBUSTIBLES DIQUES!

ATENCIÓN: LEER MUY ATENTAMENTE LAS “ADVERTENCIAS” INDICADAS EN LA PRESENTACION DEL MANUAL.

OPERACIONES PERIODICAS

- Limpie y controle de los filtros de las valvulas de gas (vease parrafo siguiente)
- Desmonte, controle y limpie el cabezal de combustión (véase Fig. 13 y siguientes)
- Limpie y controle los electrodos de encendido y deteccion (véase Fig. 15). Controle la señal de detección, siga el esquema de la Fig. 30-Fig. 31.
- Limpie y engrase los mecanismos de leva y las piezas giratorias.



ADVERTENCIA: si, durante las operaciones de mantenimiento, si estuviese necesario abrir las partes que componen la rampa gas, recordarse de seguir, una vez armada de nuevo la rampa, la prueba de estanqueidad según las modalidades indicadas en las normativas vigentes

Mantenimiento del filtro de gas



ATENCIÓN: antes de abrir el filtro cerrar la válvula de interceptación del gas ubicada después y purgar; asegurarse además de que en su interior no haya gas bajo presión.

Para limpiar o sustituir el filtro de gas proceder de la siguiente manera:

- 1 quitar la tapa desenroscando los tornillos de bloqueo (A);
- 2 desmontar el cartucho filtrante (B), limpiarlo con agua y jabón, aplicar aire comprimido (o sustituirlo si fuera necesario)

volver a montar el cartucho en su posición inicial, controlando que se encuentre entre las guías apropiadas y que no obstaculice el montaje de la tapa; prestando atención que la junta tórica esté ubicada en la ranura específica (C), cerrar la tapa bloqueándola con los tornillos apropiados (A).

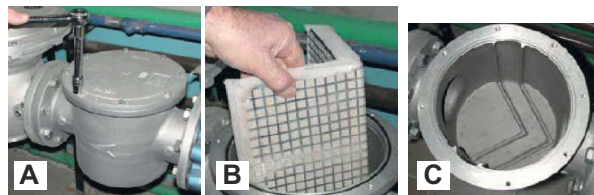

Válvulas MBE con actuadores VD... Montaje

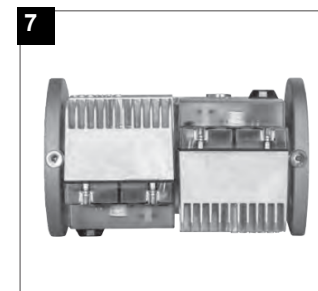
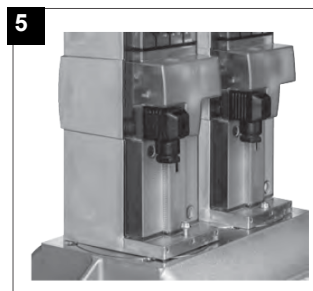
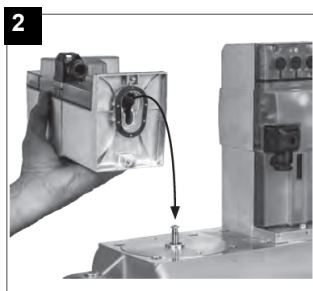
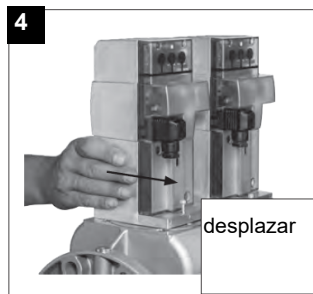
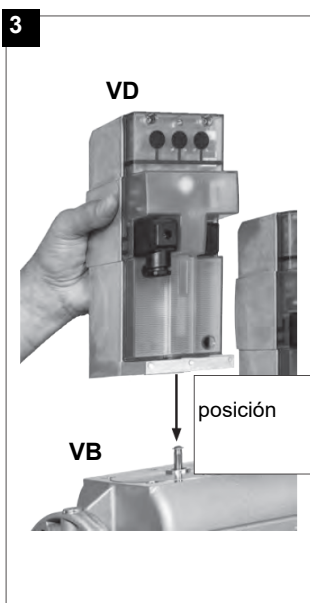
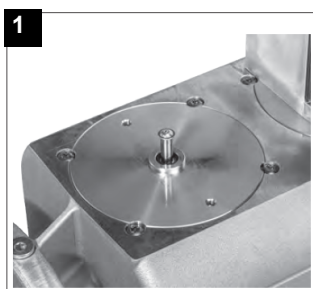

1. Colocar el VD en el VB, fig. 2+3.
2. Desplazar el VD hacia adelante hasta el tope, fig. 4.
3. Atornillar el DV con 2 tornillos M5, máx. 5 Nm/44 in.lb, fig. 5/6.
4. El VD se puede montar girado a 180°, fig. 7.

Siemens SKP15 e SKP25

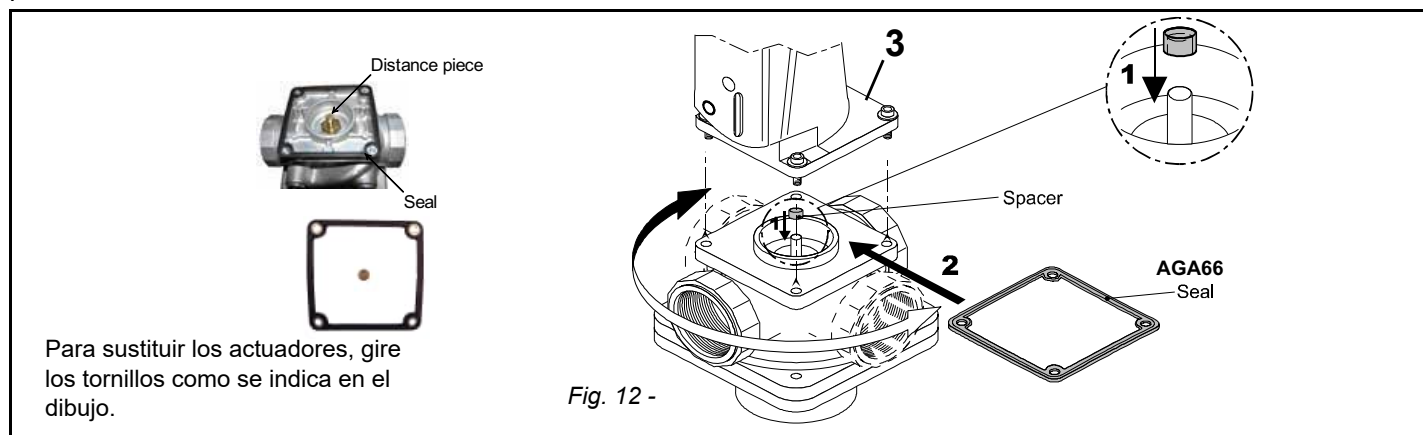

Extracción de la cabeza de combustión

- 1 Quitar la calota **C**.
- 2 Desconectar los cables de los electrodos.
- 3 Desenroscar los tornillos **V** que bloquean el colector del gas **G** a la base, y extraer el grupo como se muestra en la figura.
- 4 Limpiar la cabeza de combustión aspirando las impurezas; eliminar las eventuales incrustaciones utilizando un cepillo metálico.

Nota: para el posterior montaje, realizar las operaciones antes descritas en orden inverso, prestando atención al correcto posicionamiento de la junta tórica entre el colector de gas y el quemador.

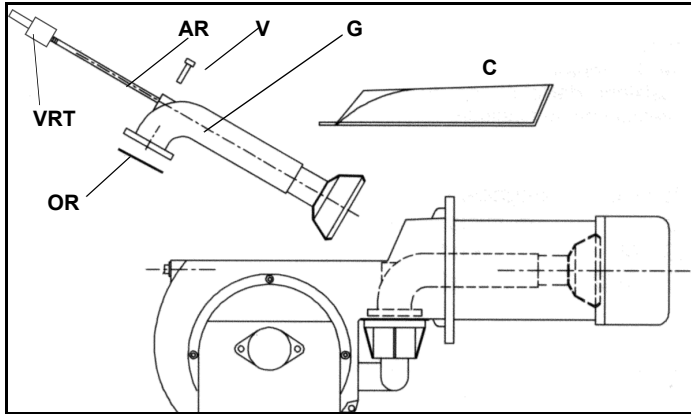

Leyenda

- VRT Tornillo regulacion cabeza combustion
- AR Varilla roscada
- V Tornillo de fijacion
- G colector del gas

- OR "O" ring
- C calota

Fig. 13

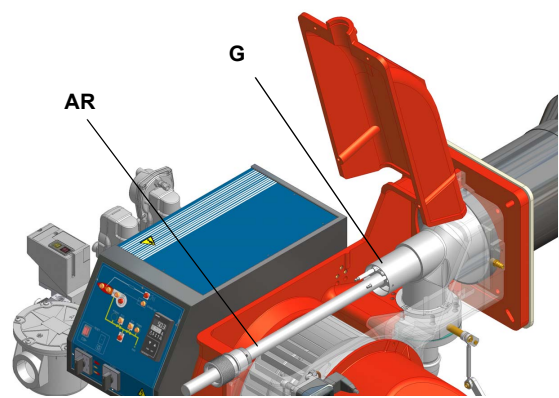
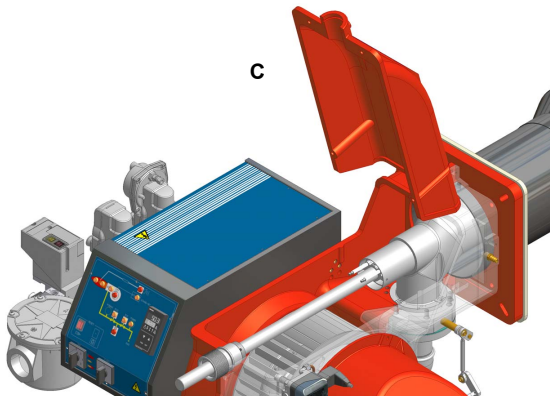

Regulación de la posición de los electrodos

NOTA: El control de los electrodos de encendido y de detección se realiza tras haber desmontado la cabeza de combustión.

	ATENCIÓN: para no afectar el funcionamiento del quemador, evitar el contacto de los electrodos de encendido y detección con partes metálicas (cabeza, boca, etc.) Controlar la posición de los electrodos después de cada intervención de mantenimiento en la cabeza de combustión.
--	--

Controlar que la distancia entre el electrodos de encendido sea de 4 mm. (ver Fig. 26).

TP90A-91A-92A-93A

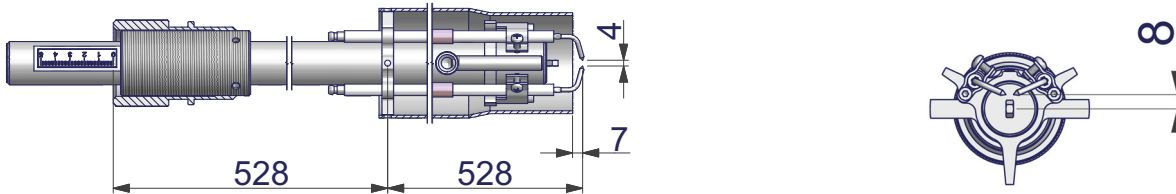

Fig. 14

TP512A-515A-520A-525A

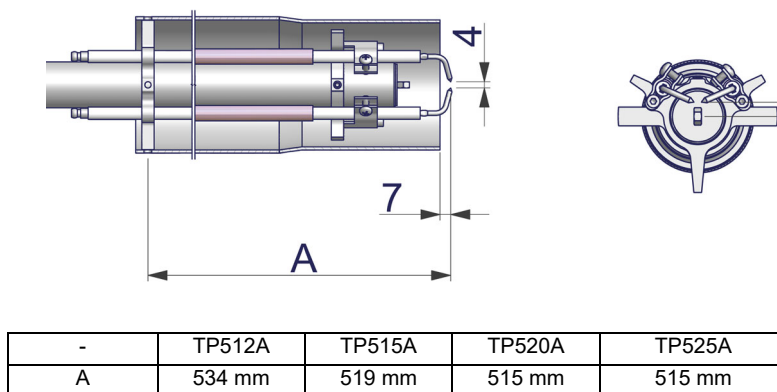

Fig. 15

Sustitución de los electrodos de encendido (if provided)

	ATENCIÓN: para no afectar el funcionamiento del quemador, evitar el contacto de los electrodos de encendido y detección con partes metálicas (cabeza, boca, etc.) Controlar la posición de los electrodos después de cada intervención de mantenimiento en la cabeza de combustión.
--	--

Para poder cambiar los electrodos de encendido se debe proseguir de la siguiente forma:

- 1 sacar el casquillo del quemador;
- 2 destornillar las tuercas que tienen fijados los electrodos a la cabeza de combustión (A);
- 3 sacar los cables de los electrodos (B) ;
- 4 aflojar los tornillos que bloquean la perilla de regulación (C)
- 5 mover hacia afuera el grupo de electrodos de encendido y extraerlos de la cabeza de combustión (D) ;
- 6 aflojar los tornillos del soporte de bloqueo de electrodos de encendido (E)
- 7 extraer los electrodos y sustituirlos haciendo referencia a las cotas indicadas en la figura (F-G).

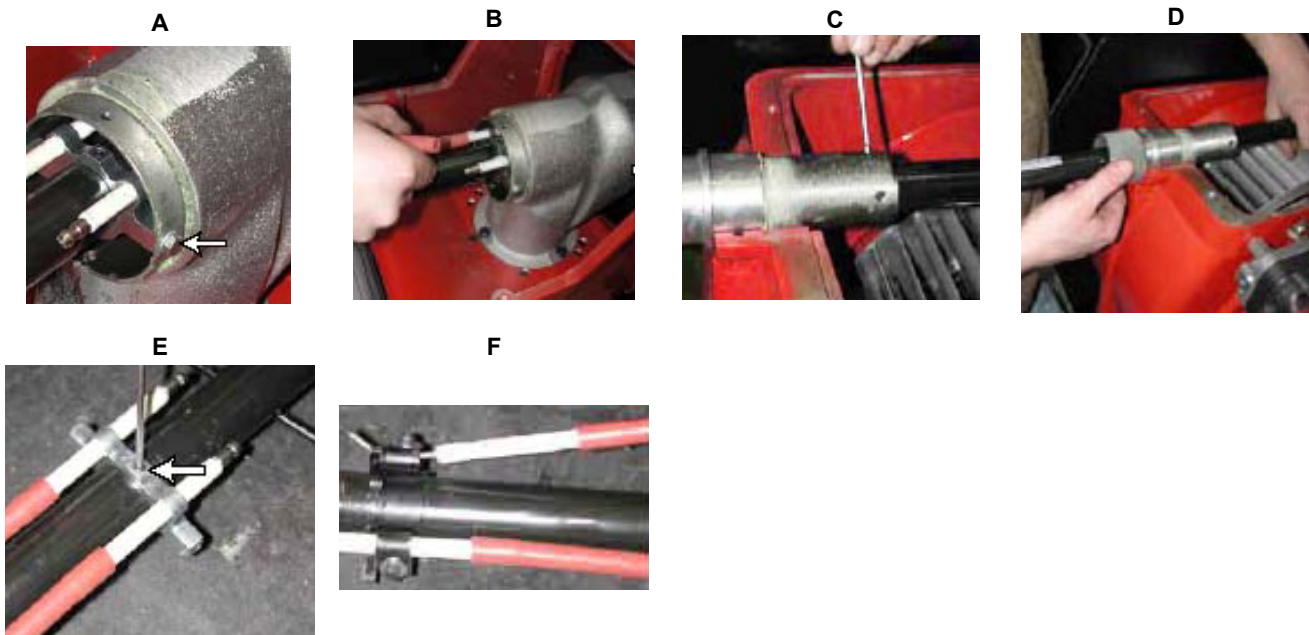

Sustitución del electrodo de detección (quemadores de gas natural)

Para sustituir el electrodo de detección, proceder de la siguiente manera:

- 1 extraer la cabeza de combustión como se indica en el apartado “Extracción de la cabeza de combustión”
- 2 utilizando una llave a brugola aflojar las vides de bloqueo del electrodo de encuesta ER y reemplazarlo;
- 3 reensamblar la cabeza de combustión.

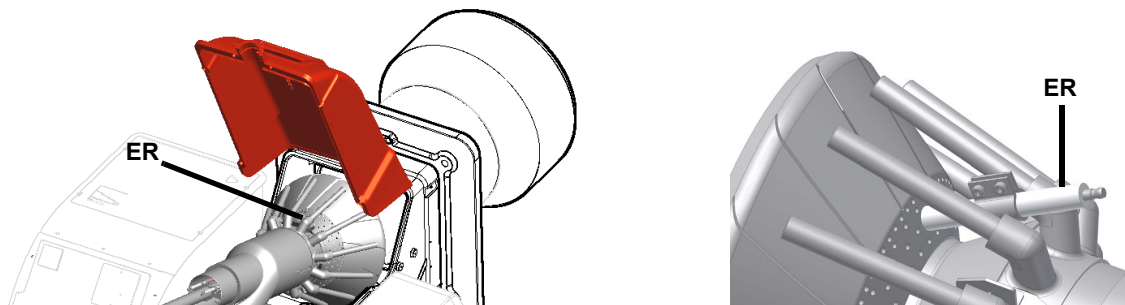

ATENCIÓN: para no afectar el funcionamiento del quemador, evitar el contacto de los electrodos de encendido y detección con partes metálicas (cabeza, boca, etc.) Controlar la posición de los electrodos después de cada intervención de mantenimiento en la cabeza de combustión

Control de la corriente de detección con electrodo (Gas natural)

Para medir la señal de detección, seguir el esquema indicado en figura. Si la señal es inferior al valor indicado, controlar la posición del electrodo o célula fotoeléctrica de detección, los contactos eléctricos y, eventualmente, sustituir el electrodo de detección o célula fotoeléctrica.

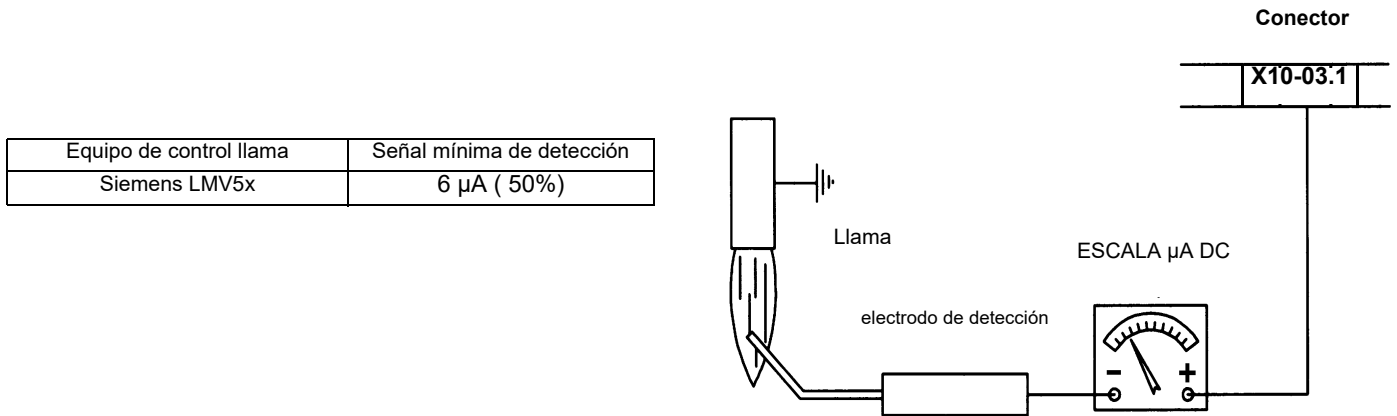

Término de servicio del quemador

- En condiciones de funcionamiento óptimas y con mantenimiento preventivo, el quemador puede durar hasta 20 años.
- Al expirar el término de servicio del quemador, es necesario realizar un diagnóstico técnico y, si es necesario, llevar a cabo una reparación general.
- Se considera que el estado del quemador está en el límite si es técnicamente imposible continuar usándolo debido al incumplimiento de los requisitos de seguridad o debido a una disminución en el rendimiento.
- El propietario toma la decisión de finalizar el uso del quemador o el reemplazo y la eliminación en función del estado real del aparato y los costos de reparación.
- El uso del quemador para otros fines que no sean la expiración de los términos de uso está estrictamente prohibido.

Parada estacional

Para apagar el quemador en el período de parada estacional, proceder de la siguiente manera:

- 1 poner el interruptor general del quemador en posición 0 (OFF - apagado)
- 2 desconectar la línea de alimentación eléctrica
- 3 cerrar el grifo de combustible de la línea de distribución.

Eliminación del quemador

En caso de desguace del quemador, seguir los procedimientos previstos por las leyes vigentes acerca de la eliminación de los materiales.

ESQUEMAS ELECTRICOS

Consultar el esquema eléctrico adjunto.

ATENCIÓN:

- 1 - Alimentación eléctrica 230V / 400 V 50 Hz 3 N CA. trifásica
- 2 - No invertir la fase con el neutro
- 3 - Prever una buena conexión de tierra del quemador

TABLA DESCRIPCIÓN DE PROBLEMAS - CAUSAS - SOLUCIONES Funcionamiento del gas

EL QUEMADOR NO SE ENCIENDE	No hay suministro de energía	Ripristine l'alimentazione
	Interruptor principal abierto	Cerrar el interruptor
	Termostatos abiertos	Revisar los puntos de ajuste y las conexiones de los termostatos
	Mal punto de ajuste o termostato roto	Resetear o reemplazar el termostato
	Falta de presión de gas	Restablecer la presión
	Abrir los dispositivos de seguridad (ajuste manual del termostato de seguridad, del presostato u otro)	Reajustar los dispositivos de seguridad; esperar a que la caldera alcance la temperatura requerida y comprobar el funcionamiento de los dispositivos de seguridad.
	Fusibles rotos	Reemplazar los fusibles. Comprobar la corriente absorbida
	Abre los contactos térmicos del ventilador (sólo para trifásicos)	Restaurar los contactos y comprobar la corriente absorbida
	Equipo de control de la llama del quemador en bloqueo	Restaurar y comprobar la funcionalidad
Equipo de control de la llama del quemador dañado	Reemplazar el equipo de control de la llama	
QUEMADOR EN BLOQUE SIN PRESENCIA DE LLAMA	Caudal de gas demasiado bajo	aumentar el caudal de gas comprobar la limpieza del filtro de gas comprobar la apertura de la válvula de aceleración cuando el quemador se pone en marcha
	El electrodo de encendido se descarga a tierra porque está sucio o roto	Limpiar o reemplazar el electrodo
	Mal ajuste de los electrodos	Comprobar la posición de los electrodos según los dibujos del manual
	Cables de encendido dañados	Reemplazar los cables
	Cables mal conectados al transformador o a los electrodos	Realizar las conexiones de nuevo
	Transformador de encendido dañado	Reemplazar el transformador
QUEMADOR EN BLOQUE CON PRESENCIA DE LLAMA	Ajuste incorrecto del detector de llamas	Ajustar el detector de llamas
	Detector de llamas dañado	Reemplazar el detector de llamas
	Los cables o el detector de llamas están dañados	Revisa los cables
	Equipo de control de llama dañado	Reemplazar el equipo de control de la llama
	Fase y neutro invertidos	Hacer las conexiones de nuevo
	Falta la conexión a tierra o está dañada	Revisa las conexiones de tierra
	Voltaje en neutro	Quitar el voltaje del neutro
	Llama demasiado pequeña (debido a la poca cantidad de gas)	Ajustar la tasa de flujo de gas Comprueba la limpieza del filtro de gas
	Demasiado aire	Ajustar la tasa de flujo de aire
sólo para LME22 - EL QUEMADOR REALIZA LOS PROCEDIMIENTOS SIN ENCENDER EL QUEMADOR	Presostato aire dañado o mal conectado	Revisar el funcionamiento y las conexiones del presostato aire
	Equipo de control de llama dañado	Reemplazar el equipo de control de llama
EL QUEMADOR SE BLOQUEA POR FALTA DE CAUDAL DE GAS	Las válvulas de gas no se abren	Comprobar la tensión de las válvulas; si es necesario, sustituir o cambiar el equipo de control de la llama Comprobar que la presión del gas no sea tan alta como para que las válvulas no puedan abrirse
	Válvulas de gas completamente cerradas	Abrir las válvulas
	Regulador de presión demasiado cerrado	Ajustarlo
	Válvula de mariposa demasiado cerrada	Abrir la válvula de mariposa
	Presostato de presión máxima abierto (si está presente)	Revisar las conexiones y la funcionalidad
	El presostato de aire no cierra el contacto normalmente abierto (NO)	Revisar las conexiones Comprobar la funcionalidad del interruptor de presión
EL QUEMADOR ENTRA EN BLOQUEO Y EL EQUIPO PROPORCIONA UN CÓDIGO DE BLOQUEO "CAUSAR FALLO DEL PRESOSTATO DE AIRE"	El presostato de aire está dañado (permanece en el modo de espera o está mal ajustado)	Comprobar el funcionamiento del presostato de aire Reajustar el presostato de aire
	Conexiones incorrectas del presostato de aire	Revisar las conexiones
	Ventilador de aire dañado	Reemplazar el ventilador
	Falta la alimentación eléctrica	Reajustar la alimentación eléctrica
	La tapa de aire está demasiado cerrada	Ajustar la posición de la tapa de aire
EL QUEMADOR SE BLOQUEA DURANTE EL FUNCIONAMIENTO NORMAL	Circuito detector de llamas interrumpido	Comprobar las conexiones Comprobar la fotocélula
	Equipo de control de llama dañado	Reemplazar el equipo de control de llama
	Presostato de máxima presión dañado o mal ajustado	Reajustar el presostato de máxima presión o sustituirlo
EN EL ARRANQUE, EL QUEMADOR ABRE LAS VÁLVULAS POR UN TIEMPO Y REPITE EL CICLO DE PRE-VENTILACIÓN DESDE EL PRINCIPIO	Presostato gas de mínima mal ajustado	Reajustar presostato gas de mínima
	Filtro de gas sucio	Limpiar el filtro de gas
	Regulador de gas demasiado bajo o dañado	Reajustar o sustituir el regulador
EL QUEMADOR SE PARA DURANTE EL FUNCIONAMIENTO SIN NINGÚN TIPO DE CONMUTACIÓN DE TERMOSTATO	Los contactos térmicos del ventilador abierto	Volver a verificar los contactos y comprobar los valores Comprobar la corriente de absorción
EL MOTOR DEL VENTILADOR NO ARRANCA	El bobinado interno del motor está roto	Reemplazar el bobinado o el motor completo
	El contactor del motor del ventilador está roto	Reemplazar el contactor
	Fusibles rotos (sólo trifásicos)	Cambiar los fusibles y comprobar el consumo actual
EL QUEMADOR NO CAMBIA A LLAMA ALTA	El termostato de llama alta y baja está mal ajustado o dañado	Reajustar o sustituir el termostato
	Servomotor incorrectamente ajustado	Resetear el servomotor
sólo versión mecánica - SIN EL CONTROL DEL SERVOMOTOR DE RUEDA EN LA DIRECCIÓN EQUIVOCADA	Condensador de servomotor dañado	Reemplazar el condensador



C.I.B.UNIGAS S.p.A.

Via L.Galvani ,9 - 35011Campodarsego (PD) - ITALY

Tel. +39 049 9200944 - Fax +39 049 9200945

website:www.cibunigas.it-e-mail:cibunigas@cibunigas.it

Note: specifications and data subject to change. Errors and omissions excepted.

Siemens LMV5x



Service Manual

Warnings:

To avoid injury to persons, damage to property or the environment, the following warning notes must be observed

Qualified personal

In the sense of this documentation, qualified personal are those who are knowledgeable and qualified to install, mount, commission, operate and service / maintain LMV5 system together with burner & boiler products.

The personal must have the appropriate qualifications to carry out these activities, for example:

Trained and authorized to energize and de-energize, ground and tag circuits and equipment according to applicable safety standards.

Trained or instructed according to the latest related standards (e.g. EN298, EN676, EN267, ..).

Notes of caution:

The equipment must be installed in compliance with the regulations in force, following the manufacturer's instructions, by qualified personnel.

Qualified personnel means those having technical knowledge in the field of components for civil or industrial heating systems, sanitary hot water generation and particularly service centres authorised by the manufacturer.

Improper installation may cause injury to people and animals, or damage to property, for which the manufacturer cannot be held liable.

Remove all packaging material and inspect the equipment for integrity.

In case of any doubt, do not use the unit - contact the supplier.

The packaging materials (wooden crate, nails, fastening devices, plastic bags, foamed polystyrene, etc), should not be left within the reach of children, as they may prove harmful.

Before any cleaning or servicing operation, disconnect the unit from the mains by turning the master switch OFF, and/or through the cut-out devices that are provided.

Make sure that inlet or exhaust grilles are unobstructed.

In case of breakdown and/or defective unit operation, disconnect the unit. Make no attempt to repair the unit or take any direct action.

Contact qualified personnel only.

Units shall be repaired exclusively by a servicing centre, duly authorised by the manufacturer, with original spare parts.

Failure to comply with the above instructions is likely to impair the unit's safety.

To ensure equipment efficiency and proper operation, it is essential that maintenance operations are performed by qualified personnel at regular intervals, following the manufacturer's instructions.

When a decision is made to discontinue the use of the equipment, those parts likely to constitute sources of danger shall be made harmless.

In case the equipment is to be sold or transferred to another user, or in case the original user should move and leave the unit behind, make sure that these instructions accompany the equipment at all times so that they can be consulted by the new owner and/or the installer.

For all the units that have been modified or have options fitted then original accessory equipment only shall be used.

This unit shall be employed exclusively for the use for which it is meant. Any other use shall be considered as improper and, therefore, dangerous.

The manufacturer shall not be held liable, by agreement or otherwise, for damages resulting from improper installation, use and failure to comply with the instructions supplied by the manufacturer.

1	WIRING RECOMMENDATIONS	4
1.1	Earthing	4
1.1.1	TN earthing system	4
1.1.2	Protective Earth (PE) and Functional Earth (FE).....	4
1.2	.Frequency inverter / Variable Speed Drive (VSD).....	5
1.3	Ignition electrodes and transformers	5
1.3.1	Recommendations	6
1.3.2	Shielding	6
1.4	Wireway and electrical conduit.....	7
1.4.1	Servomotor wiring example	9
1.4.2	Bus cable wiring on LMV5x and AZL doors	9
1.4.3	EARTH connection example.....	9
2	AZL display/programming unit	10
2.1	LMV5x program operating phases	11
2.2	LMV5x program structure.....	12
2.3	Burner ID number	13
2.4	Password.....	14
2.4.1	Access to service levels by password.....	14
2.4.2	Password Logout.....	14
2.4.3	Changing password.....	14
3	Thermostatic series and safety loop	15
4	Actuators	16
4.1	Addressing the actuators	16
4.2	Actuator doors configuration	17
4.3	Setting the actuator speed	17
5	Setting the load controller	18
6	Setting the probes and set-points	19
6.1	Configuration of a temperature probe at X60 door.....	19
6.2	Configuration of a pressure or a temperature probe type at X61 door	20
6.2.1	Configuration of a pressure or a temperature probe signal at X61 door	20
6.3	Configuration of the X62 door input signal.....	20
6.4	Setting the setpoint and the burner and the PID operative band.....	21
6.4.1	Set-point.....	21
6.4.2	SD_ModON e SD_Mod Off.....	21
6.4.3	PID control parameters.....	22
6.5	Setting functions "TL_ThreshOff" and "TL_SD_On".....	23
7	VSD Standardization.....	24
8	SPECIAL POSITIONS	25
8.1	Ignition position.....	25
8.2	Prepurge position.....	25
8.3	Home position.....	25
8.4	Postpurge position	25
9	ADJUSTING THE AIR/FUEL RATIO CURVES.....	26
9.1	Fuel burner settings - curve-points	26
9.2	Setting the load points output (burners with no FGR).....	27
10	Configurations for burner with FGR.....	30
10.1	Recommendations	30
10.2	Address and activate the AUX3 servomotor.....	31
10.3	Setting the special positions.....	32
10.4	Setting the load controller mode: see the previous chapter (regolazione senza FGR)	32
10.5	FGR mode choice	33
10.6	Main parameter of the FGR function	34
10.7	Example of FGR factor and FGR Maps Factor on the burner regulation.....	35
11	Cold start thermal shock (CSTP).....	36
12	BURNER MANUAL OPERATION	38

1 WIRING RECOMMENDATIONS

1.1 Earthing

1.1.1 TN earthing system

For the LMV5x-System it is preconditioned that a TN earthing system is used.

In a TN earthing system, one of the points in the generator or transformer is connected with earth, usually the star point in a three-phase system.

TN-S: PE and N are separate conductors that are connected together only near the power source. This arrangement is the current standard for most residential and industrial electric systems in North America and Europe.

TN-C-S: Combined PEN conductor from transformer to building distribution point, but with separate PE and N conductors in fixed indoor wiring.

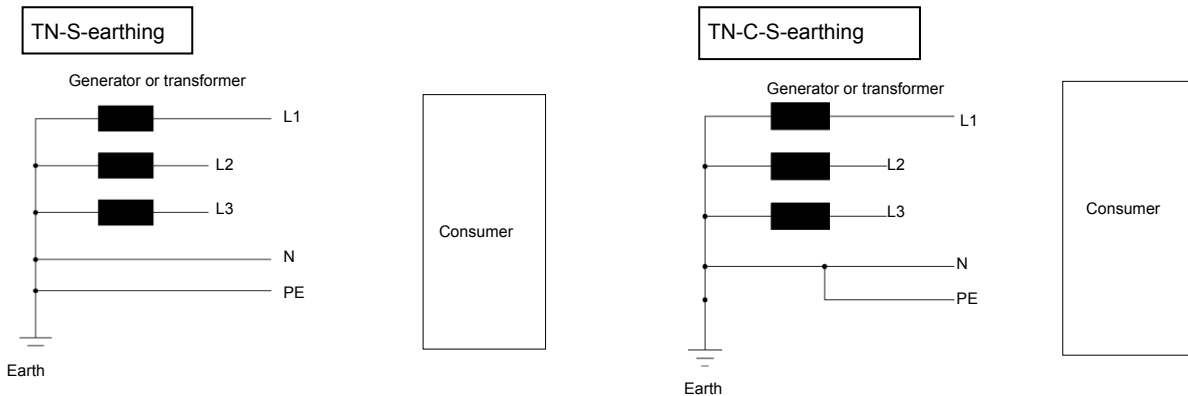

	<p>LMV system must be connected to earth (PE). ΔVolt must be 0 V between N-PE.</p> <p>NOTE: PE = protection earth, it is not FE FE = functional earth</p>
---	---

1.1.2 Protective Earth (PE) and Functional Earth (FE)

Protective Earth (PE):

Known as an equipment grounding conductor, avoids hazards by keeping the exposed conductive surfaces of a device at earth potential.

To avoid possible voltage drop no current is allowed to flow in this conductor under normal circumstances, but fault currents will usually trip or blow the fuse or circuit breaker protecting the circuit.

For example: burner body or the third wire in a 3 wire cable (N L E)

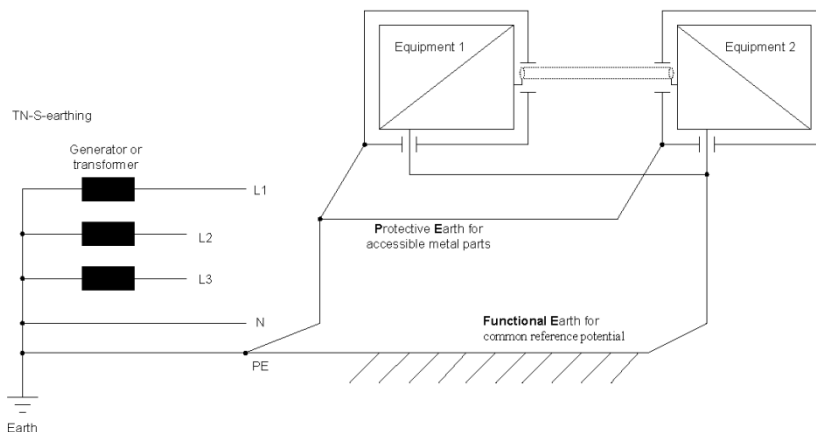

Functional Earth (FE):

Is not intended for shock protection. It is used for a common reference potential.

For example: cable shields.

1.2 .Frequency inverter / Variable Speed Drive (VSD)

A VSD is one of the strongest EMC sources in a boiler house, so the following is recommended:

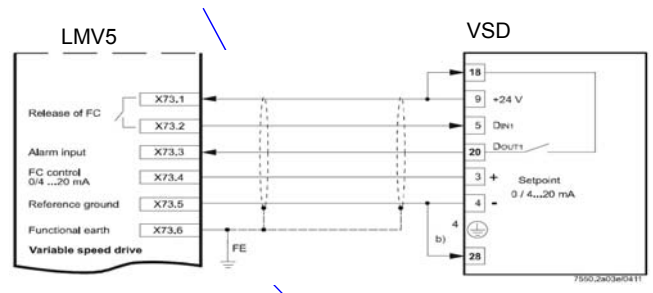
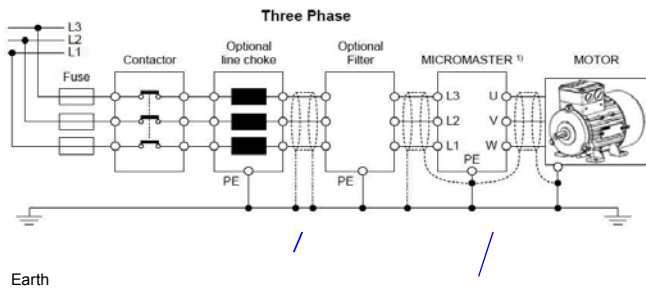

Note: If the LMV5 is mounted in a cabinet, alternative to (X73.6 / FE), also a connection with the PE- rail in the cabinet is possible

Use only VSD with EMC- filter!

Cable from VSD to the fan motor (Line voltage)

Use a complete separate and shielded cable from the VSD to the fan motor! Connect the shield at VSD- and at the motor- side with PE.

Details and further information see related VSD- documentation.

Cable from LMV5 to VSD (Low voltage)

Use a shielded cable from LMV5 to VSD. The shield of this cable has to be connected only at LMV5 side with X73.6 (FE), not at the VSD side:

1.3 Ignition electrodes and transformers

The Ignition is also one of the strong EMC sources, so the following is recommended:

- Keep the cable loop/length in the high voltage ignition circuit as short as possible.
- Use special EMC-ignition cable
- Avoid capacitive and inductive coupling to other signalpaths.
- Use separate wiring for the ignition high voltage cable, with max. possible distance to other cables and to the burner housing.
- e.g.: use a electrical insulating conduit or distance parts (e.g. plastic material), see also Appendix "Example for wiring, earthing and shielding the LMV5-System"
- Prefer a double pole ignition (see drawings below).
- When using a double probe ignition, the cables should be run close together to ensure that the area of emissions is as small as possible.

Double pole ignition: recommended

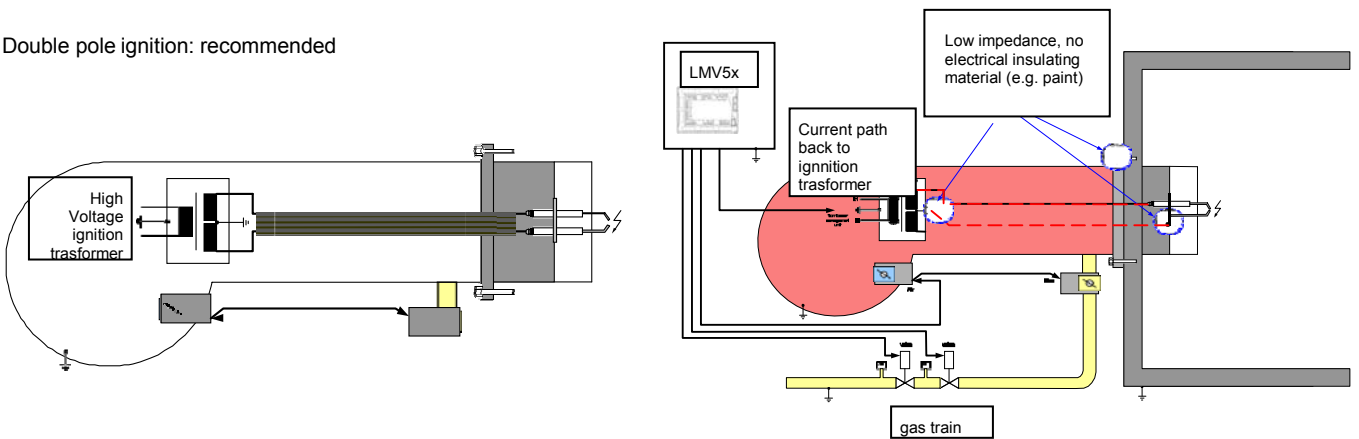

If a **single pole ignition must be used**, it is very important to have a low impedance at the mechanical connections (no insulation material, e.g. paint), because than you get a **good** current path from the ignition spark back to the ignition transformer, that results in **low** EMC-emissions:

If you have high impedance at the mechanical connections, e.g. caused by paint, you get **bad** multiple current paths from the ignition spark back to the ignition transformer, that results in **high** EMC-emissions

1.3.1 Recommendations

It is recommended to use a metal "mounting plate" for the LMV5 Base Unit and the Transformer AGG5.220. Use this plate to provide the Functional Earth (FE), see also [/EARTH connection example](#)

The connection of the FE to the LMV5 has to be made by connecting the X52.4 terminal with FE!



Follow exactly the shield and earth connection in the wiring diagram

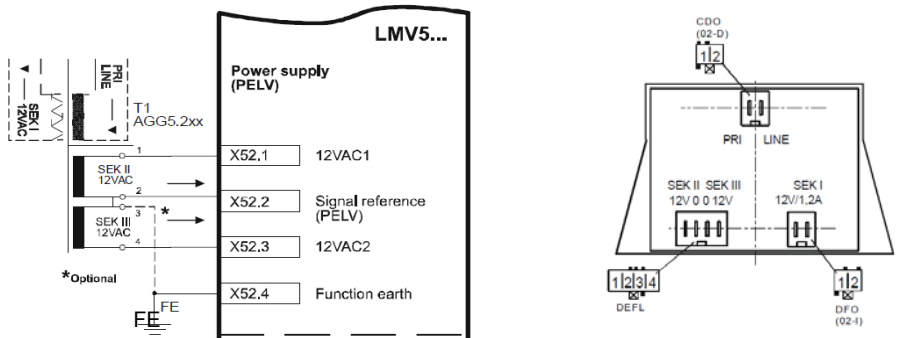

In some cases connecting the terminal X52.2 with FE results in an improved EMC- immunity of the LMV5. Make this connection and check the result, if there is no improvement, remove this connection.

The FE is wired LMV- internal to the terminals for the shields (e.g. for Temperature- & Pressure- Sensors, ...), see "4. Shielding"

To have a good connection of FE to the actuators SQM4/9, make certain that there is a proper electrical contact between the housing of the actuators and FE.

If necessary connect the actuators SQM45/48/91 with a separate cable with the maximum possible diameter to FE, see also Appendix "Example for wiring, earthing and shielding the LMV5-System"

1.3.2 Shielding

The LMV5-FE-terminals for the shields are LMV5 internally connected with X52.4, this terminal must be connect external with FE!, see also "3.3".

The shield terminals for the CAN-Bus (X50.1, X51.1) are connected direct with X52.4, the other shield terminals are connected via capacitors to prevent DC- current.

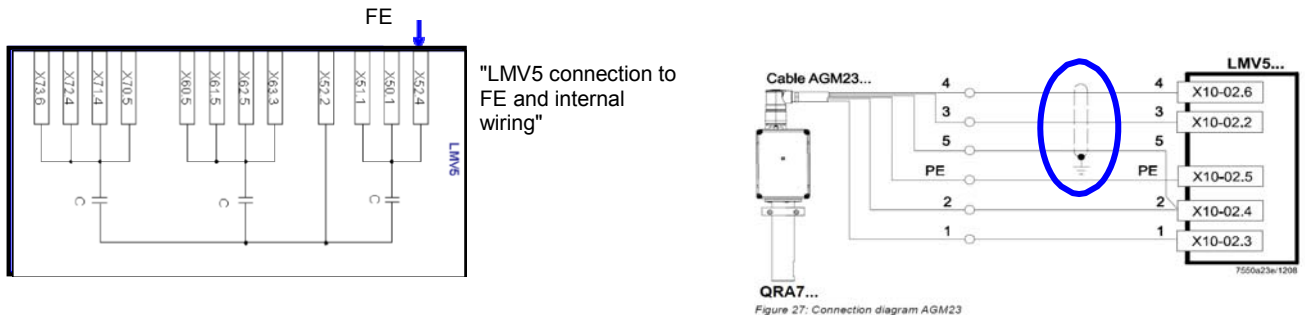

For the cables listed below use shielded cables:

For the CAN-Bus cable use AGG5.631 and/or AGG5.641 together with AGG5.110 = CAN bus connection shield, for connecting the CAN bus to the basic unit. More details see page 36 "Installation Guide CC1J7550.1"

- Cables for the VSD:
- Line voltage cable VSD - Fan motor
- Low voltage cable LMV5 – VSD (terminals X73)
- Cables for Temperature or Pressure sensors, set points, load output at the LMV5 Base Unit: X60, X61, X62, X63
- Cables for the Fuel Counters at the LMV5 Bas Unit: X71, X72
- Cable for the Speed sensor: X70
- Cable for the QGO20 sensor at the PLL52: X81
- Cables for Temperature sensors at PLL52: X86, X87

(only if present) Cable for QRA7- Signal wires no. 3, 4 and 5, for cable length > 10m and < 100m; consider reinforced insulation to signal cable and connect it to PE at the cabinet PE- rail.

1.4 Wireway and electrical conduit

The following cables are recommended for separate wiring;

Complete separate from all other cables:

- Cable for "VSD to Fan motor" Line voltage, see also "1. Frequency inverter / Variable Speed Drive (VSD)"
- Cable for ignition high voltage, see also "2. Ignition"
- Cable for the Flame sensors

Together in cable duct 1 for Low voltage, e.g.:

- Cable for CAN-Bus
- Cable for VSD speed sensor, LMV5 X70
- Cable for VSD Release & Set point , LMV5 X73
- Cables for the Load controller: Temperature or Pressure sensor, set point, load output at the LMV5 X60, X61, X62, X63

Together in cable duct 2 for Line voltage, e.g.:

- Cable for Ignition transformer
- Cables for other Line voltage signals, e.g. Gas pressure switches, Air pressure switches,
- Cable for Gas valves SKP/VGD

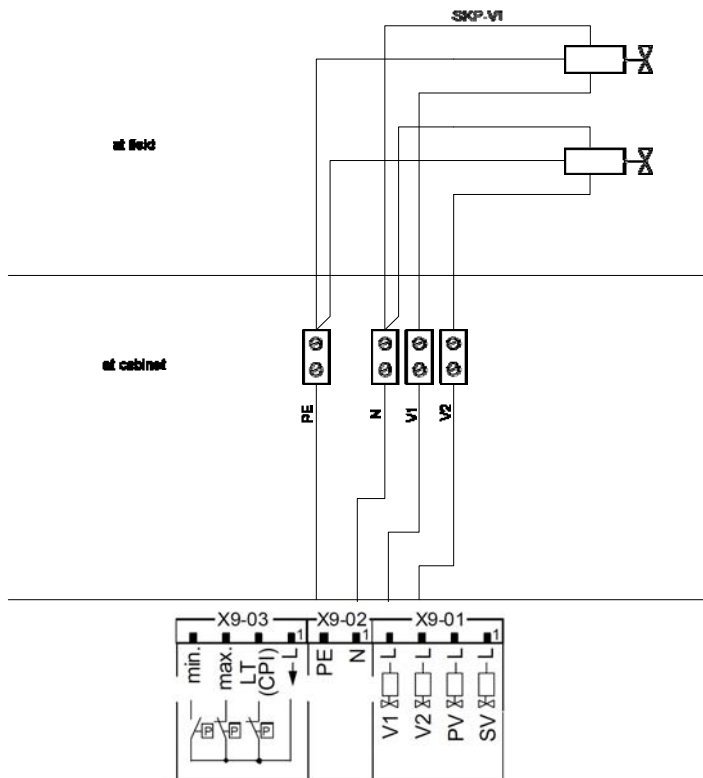

The cables from the LMV5 to the SKP/VGD -Gas vales shall be connected at the LMV5 side with X9-01: L-Valve1, L-Valve2 and with X9-02, N, PE) and connected at the SKP side separate to each SKP.

Example of wiring, see next paragraph [Wireway and electrical conduit](#)



NOTE: KEEP SEPARATE SIGNALS CABLES, OUTPUT CABLES, PHOTOCCELL CABLE AS SHOWN IN THE BELOW PICTURE

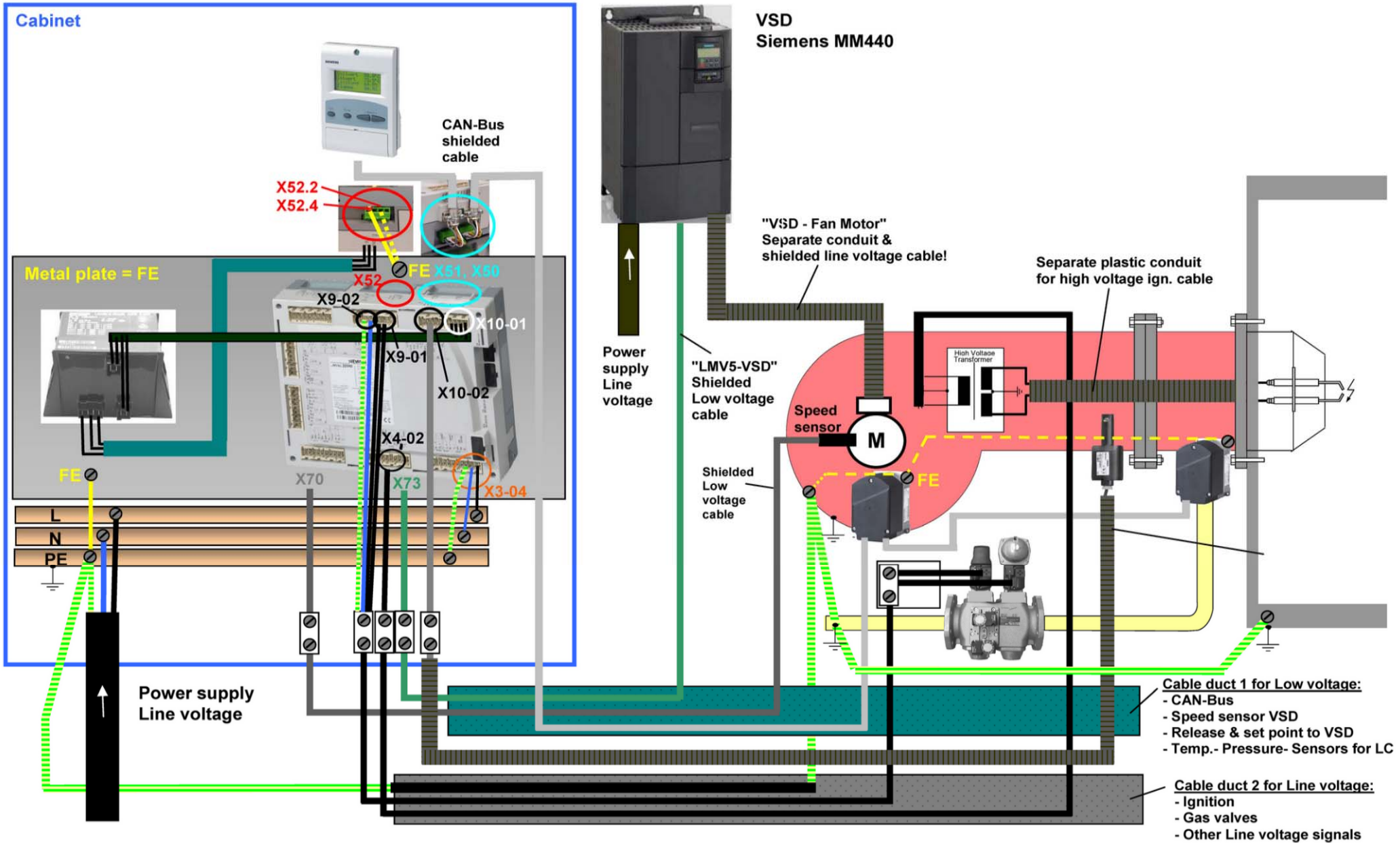

1.4.1 Servomotor wiring example



1.4.2 Bus cable wiring on LMV5x and AZL doors.



1.4.3 EARTH connection example



2 AZL display/programming unit

Users can set only the LMV parameters that can be accessed without password: (see "Adjusting the temperature set-point"). The Siemens AZL User Interface allows programming the Siemens LMV control box and monitoring the system data.





The user interface is made of:

display: it shows menus and parameters

ESC  key (previous level): it goes back to the previous level menu or exits the programming mode without changing data.

ENTER  key (next level): it confirms the data changing and jumps to the next menu/parameter.

SELECT   keys: they select a menu item and change the parameter values.

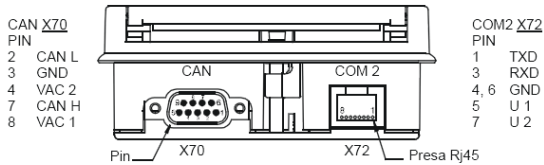

AZL5x provides three sockets to interface with other devices:

X70 socket for CAN bus connection: it provides power supply to display also.

COM1 (X71) for connection to PC/laptop by RS232 connector

COM2 (X72) for connection to building automation system by RJ45 connector.

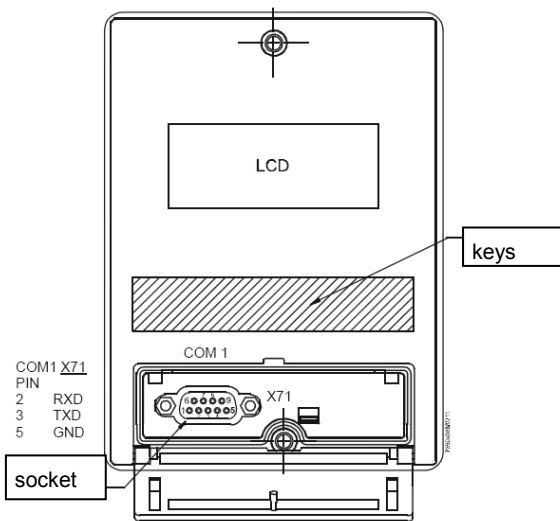

Note: COM1 and COM2 ports do not work at the same time.



Caution: when MODBUS in active, it is not possible to execute the backup via ACS450; if backup is executed the set-point will be missing and the burner will immediately turns off.

2.1 LMV5x program operating phases

Phase number	Description	Sequence
10		Home run
12		Stand by
20,21	Waiting to start realase	Startup
22	Start fan on	Startup
24	Driving to pre-purge	Startup
30....34	Pre purging	Startup
36	Driving to ignition pos	Startup
38	Ingnition pos	Startup
40,42,44	Fuel release 1	Startup
50,52	Fuel release 2	Startup
54	Driving to low flame	Startup
60,62	Shut-down low fire	Operation
70,72	Driving to prepurge	Shutdown
74....78	Post-prepurging	Shutdown
79	Test Air PressSwitch	Shutdown
80....83		Valve proving
01		Safety Phase
00		Lockout

At burner startup, the AZL display shows, one by one, the various phases of the start-up program, until it reaches normal operation phase (Phase 60).

LMV5x controller is factory preset. Changing are possible according to the password input





By closing the "thermostat series" and once the start-up sequence is accomplished (from phase 12 to pahse34), the burner is driven to the factory-set ignition position (phase 38).

The burner remains in that position because this is the only one work point in memory.

The fuel/air ratio curve must be set, until the maximum load limit (100% output).

During the setting, the actuators move according to the curve points. While the actuators move, always check the combustion analysis, point by point, and the flame stability.

The fuel/air curve points must be set during the commissioning, by a qualified operator.

	CAUTION! The procedure requires a password: qualified personnel only must check all changes to combustion parameters by means of the combustion analyzer. Remember that the password will elapse if no key is pressed for a certain period. The unit will ask for the password again
	ATTENTION! During the cold start phase, it is necessary to set the burner load. Too low output values could damage the combustion head, blast tube, oil nozzle (if present). The minimum working point must be set by qualified personal.
	CAUTION! check the combustion analysis, point by point, and the flame stability.
	ATTENTION! Set the real load output percentage at the corresponding curve-point on AZL during the burner regulation.

2.2 LMV5x program structure

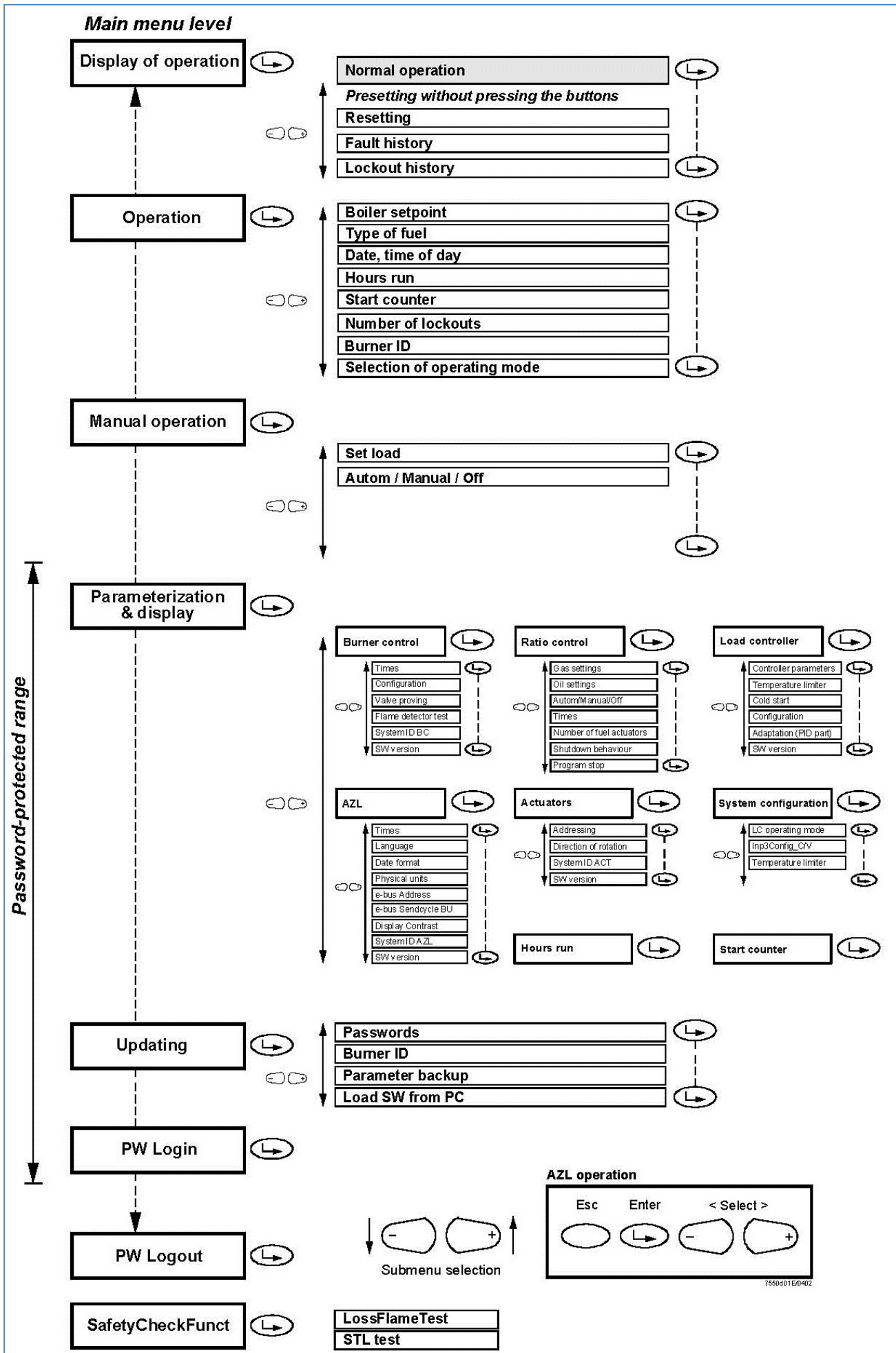

NOTE:

(1) only for LMV52.400, LMV51.300 without temperature compensation

(2) only for LMV5.200 (controlling the oxygen level in the exhaust gas flue) and LMV52.400 (monitoring the oxygen level in the exhaust gas flue, a lock out occur if a limit value is overcoming)

(3) Only for LMV51.300 (in this case VSD cannot be used), LMV52.xxx

	ATTENTION: LMV51.300: HAS ONE AUX. IT CAN BE SET FOR FGR OR VSD OR "VSD AND FGR" TOGETHER
--	--

	ATTENTION: IT IS RECOMMENDED TO NOT USE O2 MONITORING IF FGR IS INSTALLED AND ACTIVE
--	---

2.3 Burner ID number

The burner ID number corresponds to the **burner serial number**.

NOTE: in case of call to the Service Center, always tell the burner type and serial number (see burner data plate).

NOTE: burner ID number must be set.

Following the below route access to the programming levels of the menu:

1st level	2nd level	3rd level	4th level	5th level	6th level	Description
OperationalStat						
	BurnerID					Identification of burner

the product ID number is an OEM parameter, entered by the burner manufacturer and it can not be changed; it consist of minimum 4 and maximum 15 characters.

2.4 Password

2.4.1 Access to service levels by password

Depending on password (service or OEM), different parameters are visible.

"Service" parameters, as per the actuator curves and the set-point values, are password protected. The operator must logon using the "9876" password.

"User" level doesn't need a password.

If a password shall be entered, line Enter password is selected by means of decrementing (pointer points to the first character of that line) and then finally selected by pressing Enter.

Then, the pointer jumps to the first position of the password entry line. Now, through incrementing or decrementing, a character (digit or letter) can be selected. A character is confirmed by pressing Enter. If a wrong entry has been made, the last character can be edited again by pressing Esc.

The other password positions can be selected, edited and entered in a similar way. Hence, when making an entry, only 1 character is visible. When the last character of the password is reached, the entry is to be confirmed by pressing Enter.



Display before the first password character is entered:

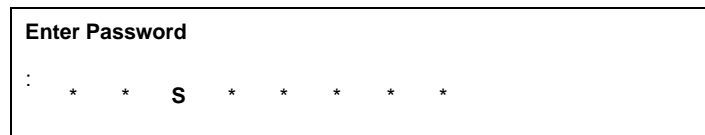

The example displays when entering the third password character:



If the check of the password entered is positive, the change to the next menu level takes place. Otherwise, the display returns to the main menu level.

To go back to the main menu, press "Esc"  until the first level menu is reached, then press the "right arrow"  till the first item is reached, then press "Enter" twice. 

2.4.2 Password Logout



To avoid customer changes on parameter settings and consequently changes in regulation, the password must be logged out. The "password logout" functions on the first level menu: press  to choose "PW Logout" then press "Enter".

Note: if no key is pressed within a settable period, the password is deactivated automatically.

Note: if a power supply drop occurs to the unit, the password will be automatically deactivated.

2.4.3 Changing password.

Following the below route access to the programming levels of the menu by means the Esc

1st level	2nd level	3rd level	4th level	5th level	6th level	Description
Updating						
	Password					To change password
		ServicePassword				For service only
		OEM Password				For OEM only

3 Thermostatic series and safety loop

The burner shuts down properly when the thermostatic series (X5-03.1 and X5-03.4 - terminals 3 and 4 of the burner terminal block) opens. In this way, before shut-down, the burner drives to the minimum load, then the fuel valve will close. The post-purging phase will be performed if set. By re-closing the thermostatic series, the burner will start-up again.

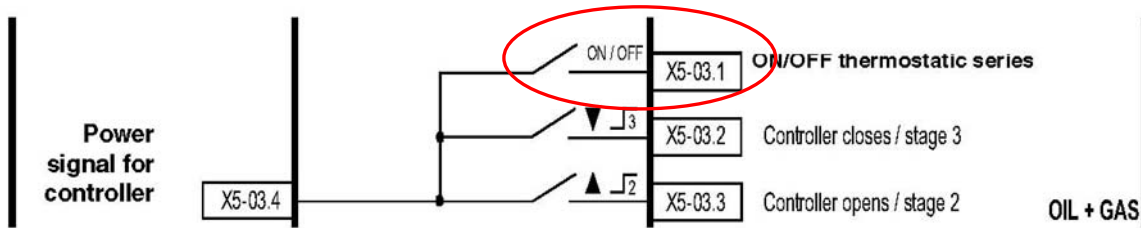

In the plant other safety devices are provided (levels, pressure switches, thermostats, air damper) . All these contacts are connected in series to the 318-319 terminals of the burner supply terminal block. When the safety loop closes, the burner is ready to restart. The actuators move to "home position" (standby position), and if terminals 3-4 are closed the start-up cycle resumes; otherwise the burner enters the standby phase.

In the plant the safety thermostat is provided as well. If this thermostat switches (terminals X3-04.1 e X3-04.2 corresponding to terminals 318 and 319 of the burner supply terminal block - see below), the system will lead to an immediate burner lockout.

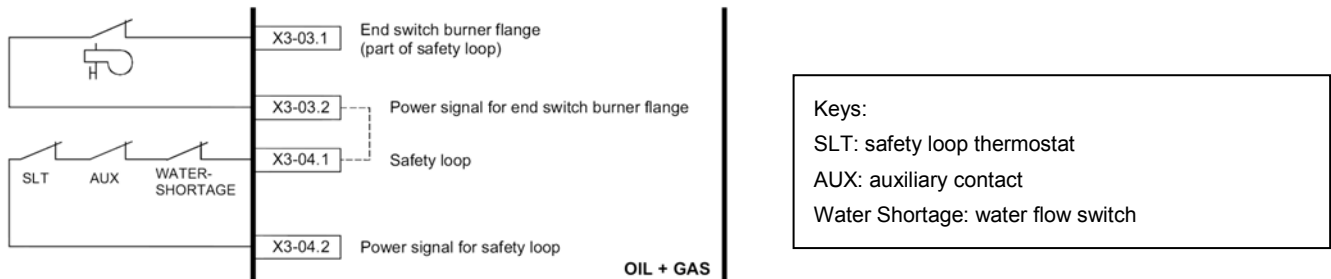

In case of burner designed with automatic pull-out system from the generator, the burner flange end switch is connected to terminals X3-03.1 e X3-03.2. If the contact open, the burner automatically shuts down.

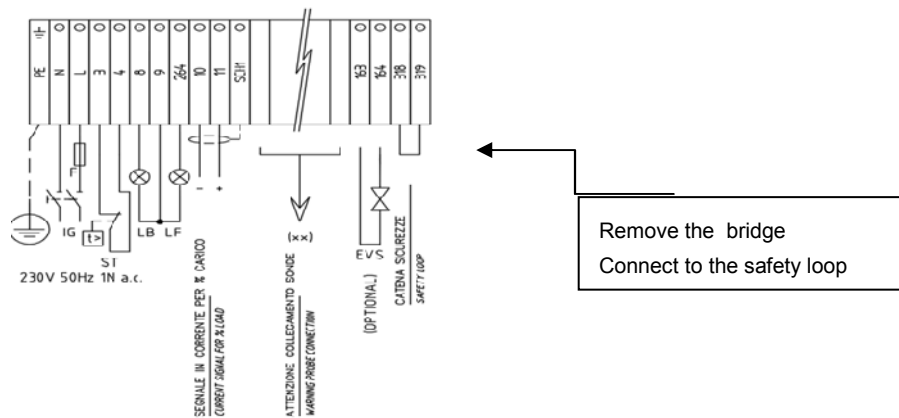

NOTE: When the safety loop opens, the burner will immediately turns off, skipping the low flame stage. It's important to distinguish between "safety loop" and "thermostatic series"

The maximum number of emergency shut-downs is 16. When this number is reached a lockout will occur AZL will show the message: "Open safety loop".

Following the below route access to the programming levels of the menu:

1st level	2nd level	3rd level	4th level	5th level	6th level	Description
Params & Display						Menu level for making the parameter settings
	BurnerControl					Setting the burner control parameters
		Configuration				
			RepetitCounter			It sets the maximum number of possible repetitions
				SafetyLoop	1...16	Default is set on 16



4 Actuators

4.1 Addressing the actuators

The addressing assigns to each actuator its proper function. The addressing is factory set by the burner manufacturer.

If an actuator must be replaced, it is necessary to address it, otherwise the system will not work. The parameter that sets the actuator function is protected by the Service level password. Remember to check that the jumper "Bus termination" of the last actuator on the CAN bus is set to "On", before starting addressing.

Following the below route access to the programming levels of the menu by means the Esc

1st level	2nd level	3rd level	4th level	5th level	6th level	Description
Params & Display						
	Actuators					
		Addressing				Addressing unad- dressed actuators
			AirActuator GasActuat (Oil) OilActuator AuxActuator 1 AuxActuator 2 AuxActuator 3 (**)			(**) used with FGR

To address an actuator, choose the corresponding actuator and follow the instructions on display:

When the actuator green LED flashes, it means that one of the following function is set according to the number of blinks:

Blinks	Actuator function
1 blink	air damper actuator
2 blinks	gas butterfly valve actuator
3 blinks	oil pressure governor actuator
4 blinks	auxiliary actuator AUX1
5 blinks	auxiliary actuator AUX2
6 blinks	auxiliary actuator AUX3

If the burner is equipped with FGR, AUX3 must be used



CAUTION: it is recommended not to adjust the actuators. Anyway, never press the actuator red button, otherwise the fundamental parameters, necessary for the burner operation, will be cancelled. The burner will therefore continuously lock out

In case P1 was pressed for a long time, it will be necessary to perform a new addressing of the actuator.

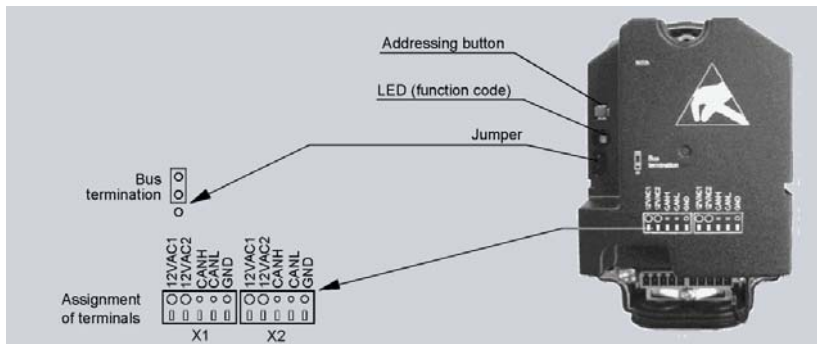







ATTENTION: when the actuator LV green LED is always lit, it means that the actuator has not been addressed yet or it has been reset and needs to be addressed again.

4.2 Actuator doors configuration

After the addressing of the actuators, it is necessary to activate and to configure the operation way for each servomotor.

	ATTENTION: Activate only the actuators that are really present, otherwise an error will occur.
--	---





1st level	2nd level	3rd level	4th level	Possible choices
Params&Display				
	RatioControl			
		Gas/OliSetting		
			AuxActuator AirActuator AuxActuator1 AuxActuator2 AuxActuator3 VSD GasActuator	Deactivated Activated Air influencing (only with LMV52x if O2 control is present) (values available Only with LMV51.300) VSD = VSD only AUX3 = FGR only, without temperature compensation VSD+AUX3 = VSD and FGR

	LMV 51.300 has the possibility to operate with VGD+FGR without temperature compensation
--	--

4.3 Setting the actuator speed

LMV sees VSD as an actuator, that's why the speed ramp up and the stop times must not be higher than the actuator stroke time. If it is necessary to increase the VSD times, change the actuator stroke time also, according to the next procedure. By following the next table, set both parameter "OperatRampMod" and "TimeNoFlame" to set the ramp up/stop times for the VSD and the actuator opening speed (from 0° to 90°).

Following the below route access to the programming levels of the menu by means the Esc

1st level	2nd level	3rd level	4th level	5th level	6th level	Description
Params&Display						Menu level for making the parameter settings
	RatioControl					Parameter settings for fuel/ air ratio control
		Times				
			OperatRampMod	Service	40 s	Operating ramp modulating is the maximum speed of the actuators during operation (phase 60 ÷ 62). A setting of 30 seconds generates a maximum speed of 90° in 30 seconds (3°/s). The LMV5 calculates an individual speed for each actuator, so that all actuators reach their target positions at the same time. Range 10..60s
			TimeNo- Flame	Service	40 s	Drive ramp is the speed of the actuators when traveling to the home, prepurge, ignition, and postpurge positions. A setting of 10 seconds generates a maximum speed of 90° in 10 seconds (9°/s). Range 10..120s

	ATTENTION: It is suggested to set the ramp up and stop time to a value about 35% lower then the slowest actuator.
--	--

5 Setting the load controller

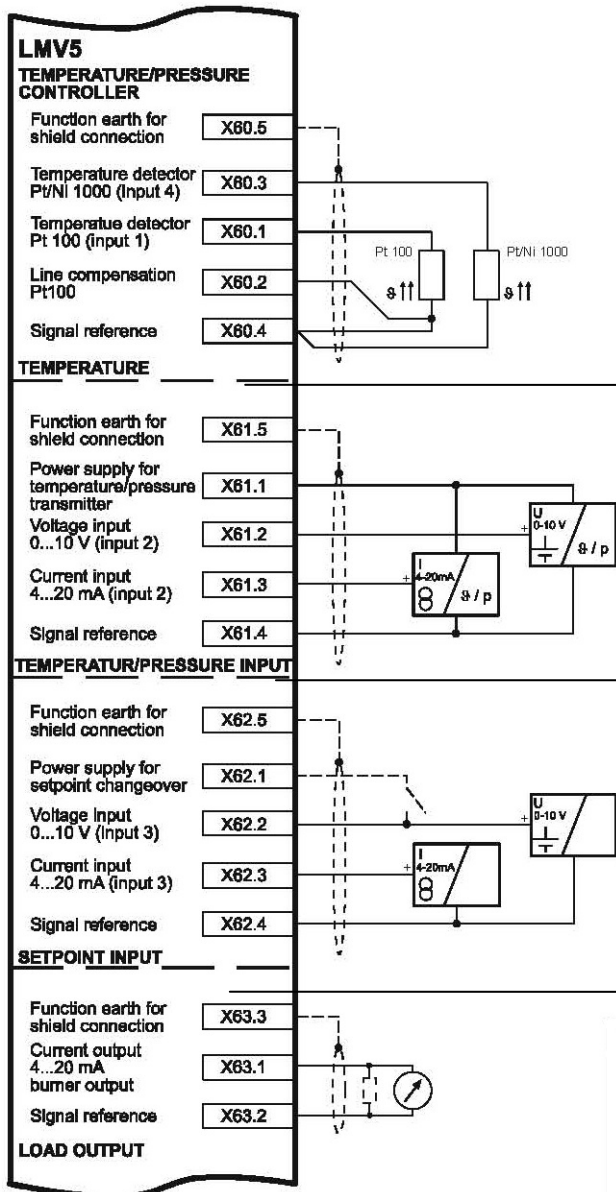

Door X60 is used for IntLC... choice and a temperature modulating probe is used.



ATTENTION: in case of FGR, it is not possible to connect a modulating temperature probe at the X60 door of the LMV5...

See the proper chapter for configuration.

Door X60 is used for IntLC... choice and a pressure probe is used.

It can be used also if the temperature probe has an analogue exit or a converter from Ohm to mA / V is used.

In this case the right input must be set.



ATTENTION: in case of FGR, it is possible to connect a modulating temperature probe at the X61 door of the LMV5...

Door X62 is used for ExtLC...

The input signal come from an external load modulator.

Door X62 is also used to switch from one setpoint to another one when IntLC... is used, by means the opening and closing of the contact between X62.1 and X62.2 terminals

Door X63 is used to remote a load % signal output from the LMV to the client DCS or PLC

Output Value Selection are: Load / Load 0 / O2 / Pos Air / Pos Fuel / Pos Aux1 / Pos Aux2 / Pos Aux3 / Speed VSD / Flame / Temp Pt1000 / TempPt1000 / Temp Pt100 / Temp X61 / Press X61)

IntLC... must be set together with a modulating probe (temperature or pressure). The probe and its signal must be configured. Doors allowed are X60 for temperature probe and X61 for pressure probes or analogue output probes.

ExtLC... must be set together with an external input signal of modulation (analogue or bus) coming from an external output modulator. The input must be configured. Doors allowed are X62 for the type of signal choice.

Following the below route access to the programming levels of the menu

1st level	2nd level	3rd level	4th level	5th level	6th level	Description
Params & Display						Menu level for making the parameter settings
	LoadController					Settings for the internal load controller
		Configuration				General configuration of the load controller
			LC_OptgMode			Operating mode with load controller
				ExtLC X5-03 Int LC Int LC Bus Int LC X62 Ext LC X62 Ext LC Bus		See below.

ExtLC X5-03 = three-point external controller (X5-03 terminals)

Int LC = internal controller (LMV5x) (it switches between 2 set points, W1,W2 set thought AZL. the switch from W1 and W2 is realized opening/closing the LMV5x... terminals X62.1, X62.2).

Int LC Bus = internal controller and set point setting via bus connection

Int LC X62 = internal controller (LMV), but set point is externally controlled by means of a voltage/current signal on X62 terminals

Ext LC X62 = external controller, the burner output is controlled by means of a voltage/current signal on X62 terminals



Ext LC Bus = external controller, the burner output is controlled via bus

	ATTENTION: in case of FGR, it is not possible to connect a modulating temperature probe at the X60 door of the LMV5... See the proper chapter for configuration.
---	--





6 Setting the probes and set-points

If the LMV5x internal load controlled is used, a temperature or pressure probe can be connected to the terminal X60 or X61. In this case, set the type of probe and its operating range.

6.1 Configuration of a temperature probe at X60 door

	ATTENTION: If the external load controller is set do not connected to terminals X60 or X61.
	ATTENTION: If the burner is equipped with FGR with temperature compensation a Pt1000 must be set.
	ATTENTION: Depending on the sensor, the value is visualized as °C or bar.

Following the below route access to the programming levels of the menu by means the Esc

1st level	2nd level	3rd level	4th level	5th level	6th level	Description
Params & Display						Menu level for making the parameter set- tings
	LoadController					Settings for the internal load controller
		Configuration				General configuration of the load controller
			Sensor Select			Select actual value input
				Pt100 Ni1000 Temp sensor Press sensor Pt100Pt1000 Pt100Ni1000 NoSensor		See the table below for the meaning of the choice.

Possible settings are:

Probe	Description
Pt100	Temperature sensor Pt100 at the input X60, internal temperature limiter function = activated
Pt1000	Temperature sensor Pt1000 at the input X60, internal temperature limiter function = activated
Ni1000	Temperature sensor LG-Ni1000 at the input X60, internal temperature function = activated
TempSens	Temperature sensor at the input X61, internal temperature switch function = deactivated
PressSens	Pressure sensor at the input X61, internal temperature switch function = deactivated
Pt100 Pt1000	Temperature sensor Pt100 at input X60 for temperature controller and temperature limiter function and temperature sensor Pt1000 at input X60 additionally for temperature limiter function
Pt100 Ni1000	Temperature sensor Pt100 at input X60 for temperature controller and temperature limiter function and temperature sensor LG-Ni at input X60 additionally for temperature limiter function.
No Sensor	No actual value sensor (e.g. in the case of external predefined loads and without internal temperature limiter).

	ATTENTION: If a boiler second probe is to be connected to terminals (1000 Ohm only), internal functions TL_ThreshOff and DiffIntervTL_SD_On are activated automatically (see paragraph SETTING FUNCTIONS "TL_ThreshOff" AND "TL_SD_On").
--	---

6.2 Configuration of a pressure or a temperature probe type at X61 door



ATTENTION: If the external load controller is set do not connected to terminals X60 or X61.

If a modulation probe is connected to the X61 terminal, proceeding as follows:

1st level	2nd level	3rd level	4th level	5th level	6th level	Description
Params & Display						Menu level for making the parameter settings
	LoadController					Settings for the internal load controller
		Configuration				General configuration of the load controller
			Ext Inp X61 U/ I			Configuration of external input X61
				4...20 mA 2...10 V 0...10 V 0...20 mA		Set the proper value according to the probe output.

6.2.1 Configuration of a pressure or a temperature probe signal at X61 door

Once the pressure sensor signal type is set, the sensor range must be set as well, proceeding as follows:

1st level	2nd level	3rd level	4th level	5th level	6th level	Description
Params&Display						Menu level for making the parameter settings
	LoadController					Settings for the internal load controller
		Configuration				General configuration of the load controller
			MRange PressSens			End of pressure measuring range for input X61
				0...99.9 bar 0...2000 °C	0...99.9 bar 0...2000 °C	Set the probe value

Example: if a max 10bar Siemens sensor is used, the voltage output signal will be 0 V at 0 bar, while the 10 V signal will correspond to its maximum pressure 10 bar. If the sensor is replaced with a max 16bar one, the 0 V output signal will correspond to 0 bar, while the 10 V output signal will correspond to 16bar pressure: the parameter "MRange Press-Sens" has to be set at 16bar.

6.3 Configuration of the X62 door input signal

Following the below route access to the programming levels of the menu by means the Esc



1st level	2nd level	3rd level	4th level	5th level	6th level	Description
Params & Display						Menu level for making the parameter settings
	LoadController					Settings for the internal load controller
		Configuration				General configuration of the load controller
			Ext Inp X62 U/I			Configuration of external input X62: input signal on X62 can change setpoint or control the load
				4...20 mA 2...10 V 0...10 V 0...20 mA		According to the external modulator output.

If a boiler second probe is to be connected to terminals (1000 Ohm only), internal functions TL_ThreshOff and DiffIntervTL_SD_On are activated automatically (see paragraph SETTING FUNCTIONS "TL_ThreshOff" AND "TL_SD_On").

6.4 Setting the setpoint and the burner and the PID operative band.

6.4.1 Set-point

To set the temperature set-point value, that is the generator operating temperature; proceed as follows.

1st level	2nd level	3rd level	4th level	5th level	6th level	Description
Params & Display						Menu level for making the parameter settings
	LoadController					General configuration of the load controller
		ControllerParam				Controller parameters

It appears the below screen:

SetPointW1 Curr: 90° New: 90°	Curr: it shows the current set-point; use the arrows keys to change it. New: it is the new set value. Enter to confirm, otherwise exit without changing by pressing ESC. Press ESC one more time to exit the set-point programming mode.
---	--



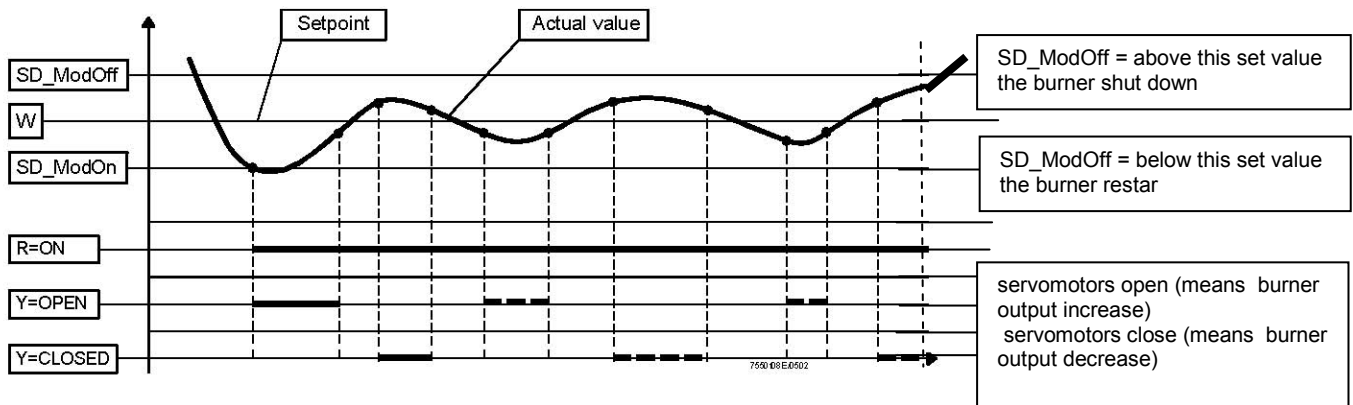

After setting the set-point it is necessary to set the operation range of the burner. See paragraph SD_ModON e SD_Mod Off

6.4.2 SD_ModON e SD_Mod Off

Once the temperature set-point W1 is stored, set the burner switch-on (SDon) and the switch-off (SDoff) point:



To set these values, choose the item SD_ModOn (SDon), by scrolling down the “Load controller” menu with the arrow keys and press ENTER:

1st level	2nd level	3rd level	4th level	5th level	6th level	Description
Params & Display				Menu level for making the	Params & Display	
	SD:ModOn			General configuration of the load		SD:ModOn
	SD:ModOff			General configuration of		SD:ModOff

the display will show:

SD_ModOn
Curr: 1.0%
New: 1.0%

SD_ModOff
Curr: 10.0%
New: 10.0%

The **SD_ModOn** default value for this parameter is 1% that is, the burner will light again at a temperature 1% lower than the set-point. Change value, if needed, by means of the arrow keys; press ENTER to confirm and the press ESC to exit. Press only ESC to exit without changing.

Now choose **SD_ModOff** always scrolling down the Load Controller menu, by means of the arrow keys, and press ENTER.

The default value for this parameter is 10% that is, the burner will turn off at a temperature 1% higher than the set-point.





Press the ENTER to confirm, the press ESC to exit. Otherwise press ESC to exit without changing data. Press the ESC to exit

6.4.3 PID control parameters

The controller's memory contains 5 standard parameter sets.

If required, 1 of these 5 PID triple values can be copied to the storage locations for the actual values so that it becomes active.

PID standard values for the following applications:

1st level	2nd level	3rd level	4th level	5th level	6th level	Description
Params & Display						Menu level for making the parameter settings
	LoadController					Settings for the internal load controller
		ControllerParam				Settings for internal load controller
			ContriParamList			Settings of controller parameter for internal load controller
				StandardParam	Adaption very fast fast normal slow very slow	

It is possible to manually set the PID parameters to any value in the setting range shown below, to activate a PID regulation from the predefined standard values described below (and edit it further if required), or to use the adaption function (self-setting function) instead of making the settings manually. The LMV5... then acquires the PID parameters itself.

See the LMV5x Siemens manual for instructions. Generally the choice of the proper pre-set PID that LMV5x suggest (very fast / fast / normal / slow / very slow) are enough for a proper operation.

Adaption	The values acquired by the LMV5... adaption function are		
	Xp [%]	Tn [s]	Tv [s]
Very fast (e.g. for small boiler)	42,5	68	12
Fast	14,5	77	14
Normal	6,4	136	24
Slow	4,7	250	44
Very slow (e.g. for large boiler)	3,4	273	48

Table shows the pre set parameter of the PID regulator according to the internal modulator reaction choice.

The parameter Xp is the proportional band in % of the set-point

6.5 Setting functions “TL_ThreshOff” and “TL_SD_On”

These functions enable the settable threshold for the immediate shutdown, if value set on TL_ThreshOff is exceeded. The automatic restart is performed for values lower than the one set on TL_SD_On.

On display, values detected by temperature/pressure probe are shown at the same time.

TL_ThreshOff turns the burner off if temperature exceeds the set value. Gas/Oil valves are suddenly closed.

TL_SD_On automatically restart the burner if the temperature is lower than the set value.

SD_ModOff automatically turns the burner to low flame and then shut down the burner if temperature exceeds the set value.

SD_ModOn automatically restart the burner if the temperature is lower than the set value.

P-Part (Xp) proportional band of modulation.

Note: this function is available if a Pt100 Ni1000 or Pt 1000 temperature sensor is connected to X60.3 and X60.4 terminals.



ATTENTION: basically, these parameters provide a function similar to the safety thermostat one, but can not replace it. The boiler must **always** operate with its safety thermostat connected properly.

NOTE: the parameter TL_ThreshOff for the immediate shutdown, must always be set to a value higher than the SD_ModOff threshold for the normal shutdown. TL_SD_On must be set at a higher temperature than SD_ModOn.

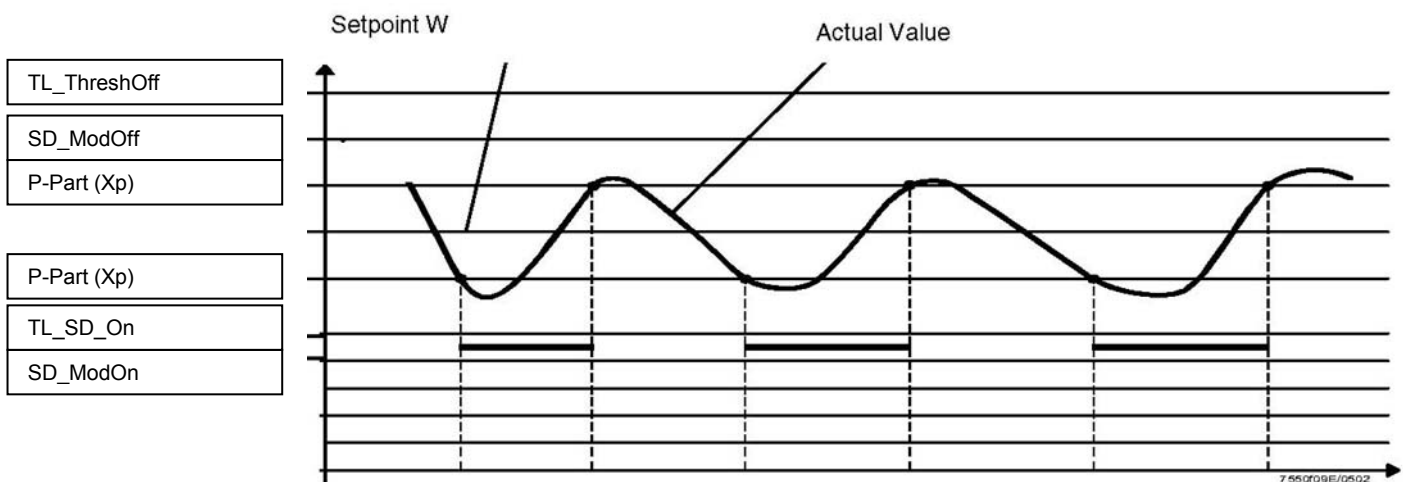

Following the below route access to the programming levels of the menu by means the Esc





1st level	2nd level	3rd level	4th level	Range		Default	Description
Params & Display							Menu level for making the parameter set- tings
	LoadController						Settings for the internal load controller
		TempLimiter					Settings for the temperature limiter function
			TL_ThreshOff	0...2000 °C		95°C	Temperature limiter OFF threshold, in °C
			TL_SD_On	-50...0% TL_Thresh_Off		- 5%	Temperature limiter switching differential ON

7 VSD Standardization



Motor standardization (speed acquisition) allows the LMV unit to control the motor rounds at the maximum frequency signal coming from the VSD. A temporary standardization is factory set only for test purpose. The definite standardization must be performed on site by the Service Center (only if the fan is supplied), before the plant test.

	ATTENTION: To perform standardization, the burner must be in stand-by mode, not it lockout stage. The Safety loop must be closed (X3-04).
--	--

Following the below route access to the programming levels of the menu by means the Esc

1st level	2nd level	3rd level	4th level	5th level	Range	Description
Params & Display						Menu level for making the parameter settings
	VSD Module					Settings for the VSD module
		Configuration				
			Speed			
				Standardization	Deactivated Activated	Standardization process for fan speed

By activating the standardization, without starting the burner up, the air actuator drives to its maximum opening. Then the fan motor starts and the VSD drives the motor to its maximum speed. The speed sensor, mounted on the motor, detects the rpm value. LMV stores the data and the motor stops.

	ATTENTION: do not enter manually the rpm value of the motor data plate on parameter "StandardizedSp".
	ATTENTION: the power cable that connects VSD to motor must be screened.

8 SPECIAL POSITIONS

8.1 Ignition position













The ignition point is independent from the other curve points of the air/fuel ratio curve.

As far as dual fuel burners, the ignition point set for the gas operation does not depend on the one set for the oil operation. LMV5x allow two different ignition position for gas mode and oil mode.

The burner is provided with a factory-set ignition point, to make easier the first ignition procedure by the Service Centre.

The air actuator at the ignition point, is factory set at a 6°/7° opening, while the gas actuator is set at 12°/15°. In case of burner provided with VSD, it is suggested to set ignition at 100% VSD frequency.

Following the below route access to the programming levels of the menu by means the Esc

1st level	2nd level	3rd level	4th level	5th level	6th level	Description
Params & Display						Menu level for making the parameter settings
	RatioControl					
		GasSettings OilSettings				Choose according to the fired fuel.
			Special Positions			
				IgnitionPos		
				HomePos		
				PrepurgePos		
				PostpurgePos		
					IgnitionPosGas	Set the proper position
					IgnitionPosAir	Set the proper position
					IgnitionPosAux 1	Set the proper position
					IgnitionPosAux 2	Set the proper position
					IgnitionPosAux 3	Set the proper position
					IgnitionPosVSD	Set the proper position

8.2 Prepurge position

Following the same route up to the 4th level, choose the pre-purge position of the servomotors

8.3 Home position

Following the same route up to the 4th level, choose the home position of the servomotors



8.4 Postpurge position

Following the same route up to the 4th level, choose the postpurge position of the servomotors

9 ADJUSTING THE AIR/FUEL RATIO CURVES



ATTENTION: when burners are provided with VSD, before setting the air/fuel ratio curves, the Standardization of the motor speed must be performed (see chapter "Standardization").

1st level	2nd level	3rd level	4th level	5th level	6th level	Description
Params & Display						Menu level for making the parameter settings
	RatioControl					Parameter settings for fuel/air ratio control
		GasSettings OilSettings				Parameter settings for firing on gas or on oil
			CurveParams			

9.1 Fuel burner settings - curve-points

Two curve points are factory set (default settings) corresponding to a hypothetical low flame stage

Note: points P1 and P2, are temporally mentioned 10% and 100% load, independently from the actual load. The operator can name the load on each point, without respecting the actual load value in that point. LMV5x will order those points automatically according to the load values set by the operator.

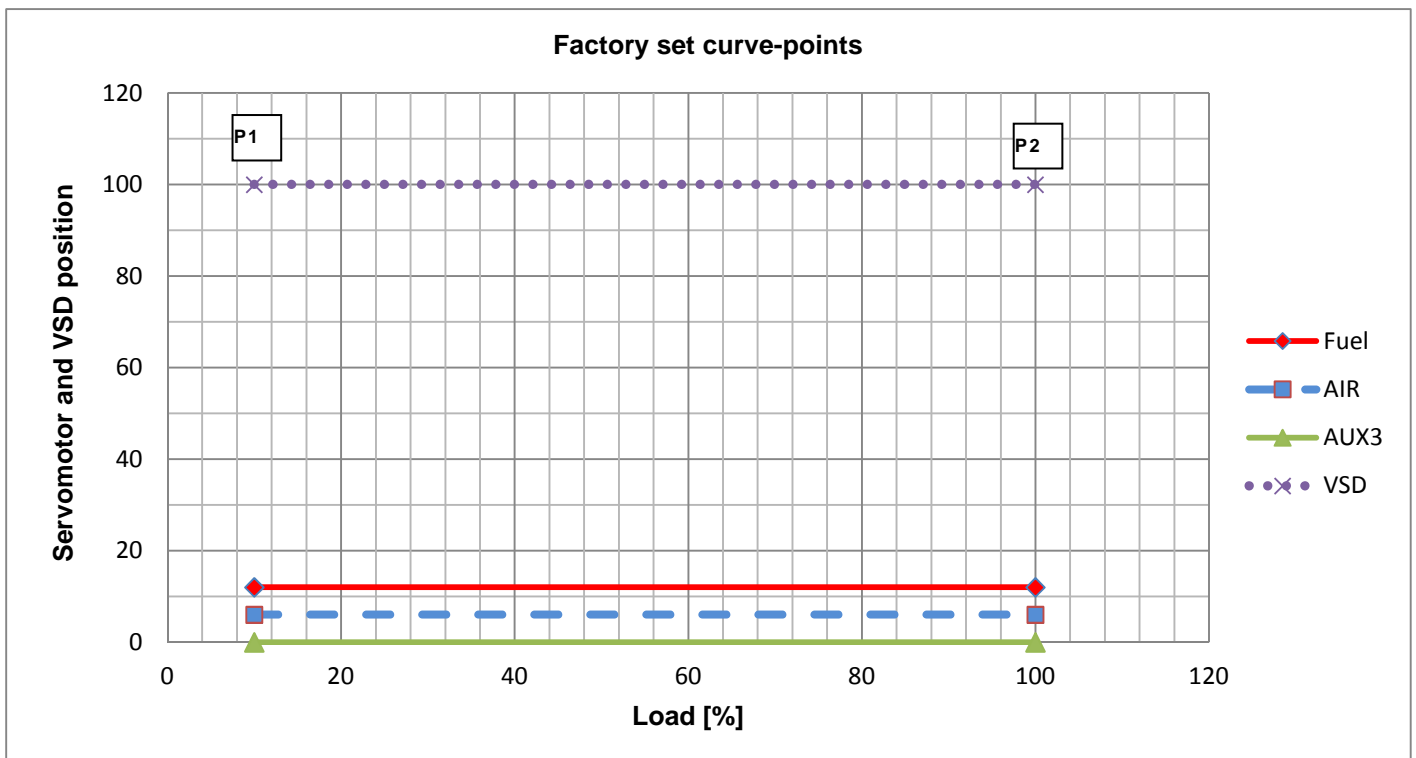



With this setting, by closing the thermostat series, the burner drives to minimum load position **P1**, after ignition. Then it drives to position **P2** without increasing the output, as both the points are set with actuators minimum opening.



ATTENTION: For burners with FGR and LMV52.400, the parameter is set to "deactivated".

9.2 Setting the load points output (burners with no FGR)



Following the below route access to the programming levels of the menu

1st level	2nd level	3rd level	4th level	5th level	6th level	Description
Params & Display						
	RatioControl					Parameter settings for fuel/air ratio control
		GasSettings GasSettings				Parameter settings for firing on Gas or on Oil
			CurveParams			At this level, the air/fuel ratio during operation is to be set.



Point	Load	10
/	Fuel	6,7
Man	Air	12
	VSD	50

Wait until symbol "v" stops twisting. It indicates that actuators are moving to the displayed position.
When the position is reached it will show the number of the point the LMV5x is at.
Press Enter  to see Point1.

Point	Load	10
 1	Fuel	12
Man	Air	6,7
	VSD	50

Press "right arrow"  to scroll to the desired point
Press Enter  to change the curve point.



Point	Load	100
 2	Fuel	12
Man	Air	6,7
	VSD	50

Press "right arrow"  to scroll to the desired point
Press Enter  to change the curve point.

Change
Delete

Select "change" to change the point, or "delete" to cancel it

Follow
Not Follow

Press "right arrow"  to scroll to the desired point
Press Enter  on "Follow". The actuator moves in real time as the operator change its setting

Point	Load	100
 2	Fuel	12
Man	Air	6,7
	VSD	50

The selector will be on Load.
By means the arrow  scroll to the desired actuator

Now it is possible to change Point2 with the next procedure

Checking continuously the air excess means of the combustion analyzer, increasing by few degrees* the air damper opening and the VSD if provided. Then increase by few degrees* the gas butterfly valve (or the fuel actuator). Go on step by step, until the butterfly valve complete opening is reached (actuator at 90° - see diagram).

The target is to reach the gas butterfly valve maximum with a sufficient excess of air. While progressively increasing the actuator positions, besides increasing the air quantity the fuel rate must be controlled by means of the valve pressure governor, in order to not exceed the requested maximum flow rate.

Once the gas butterfly valve maximum opening is reached, adjust the fuel **rate** only acting on the gas valve pressure governor (or on the oil pressure governor in case of oil).

	<p>ATTENTION: as for "increasing by few degrees" it means that the increasing must be performed in order to avoid great excess of air or defect of air.</p> <p>Therefore the increasing operation must be performed always checking the flue gas analysis by means of the combustion analyzer. It is recommended to make increasing while maintaining O2 % between max 7,5% and min 3%.</p>
--	--

It is recommended to save new points increasing the burner output at step of 10±20% load. Measuring the burner output at the flow meter. In this way, if for any reason, you must interrupt the commissioning and restart it later, you would help yourself.

Point	Load	100
:2	Fuel	12
O2	Air	6.7
	VSD	70

To choose the actuator to set, press the "left arrow"  and choose Air or VSD

Point	Load	100
:2	Fuel	12
O2	Air	6.7
	VSD	70

Press "Enter"  to access the Air actuator value to be set.





Point	Load	100
:2	Fuel	12
O2	Air	6.7
	VSD	70

Press keys    to change value.



Point	Load	100
:2	Fuel	12
O2	Air	9.5
	VSD	70

Press Enter  to confirm the value and go back to Air actuator. (Do not exit by pressing Esc from the values column because data will not be stored)

Point	Load	100
:2	Fuel	12
O2	Air	9.5
	VSD	70

Press arrows    to select another actuator to be set, for example, press  to choose Fuel)

Point	Load	100
:2	Fuel	12
O2	Air	9.5
	VSD	70

Press keys    to change the value. Press Enter to confirm the value and go back to Fuel actuator

Point	Load	100
:2	Fuel	12
O2	Air	9.5
	VSD	70

Press keys    to change value.

Point	Load	100
:2	Fuel	15
O2	Air	9.5
	VSD	70

Press Enter  to confirm the value and go back to Fuel actuator. (Do not exit by pressing Esc from the values column because data will not be stored)

Checking parameters by means of the combustion analyzer go on increasing the Air (and/or VSD if provided) and the Fuel actuators. At the end the last point will be set.



Point	Load	100
:10	Fuel	90
O2	Air	50
	VSD	85

Act on the pressure governor to adjust the fuel pressure at the proper value in order to reach the real 100% load of the generator/boiler.

Act only on the AIR or VSD actuators, to adjust the combustion.

Point	Load	100
:10	Fuel	90
O2	Air	90
	VSD	100

An example of final point will be as per the display aside, imaging to set 10 curve-points.

	ATTENTION: Set the % output load values, for every curve-point
	ATTENTION: Adjust actuators position by small changes, always checking combustion parameters.
	Caution! For safety reasons, once the maximum load point P2 is set, never go down to the minimum load point P1, without having set the other intermediate points before (see next paragraph).



Caution! In case it is necessary to immediately shut the burner down while working at high flame and the maximum load point is not already set observing the combustion parameters, decrease gas by means of the pressure governor as to drive the burner to a sufficient excess of air, then shut the burner down by the main switch.

At next start-up, start again with point P2 to the minimum load (factory-setting - see previous paragraph) and go on setting the curve points.

Commissioned curve-points - example

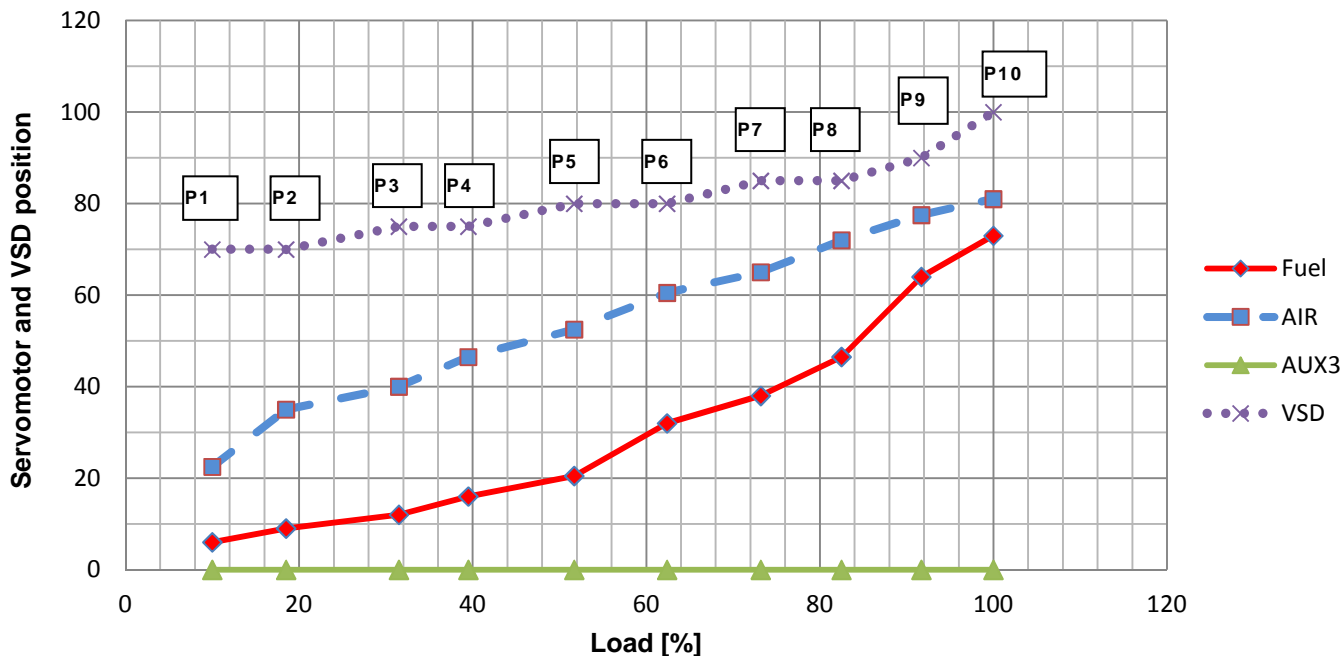

P1



ATTENTION: When the maximum load is reached (100%), check again the curve-points. The pressure at the governor has changed and therefore also the gas flow rate to the other points. So, it is necessary to check the adjustment of the points already set.



ATTENTION: for proper operation, it is necessary that the curve of each actuator does not reverse its slope.





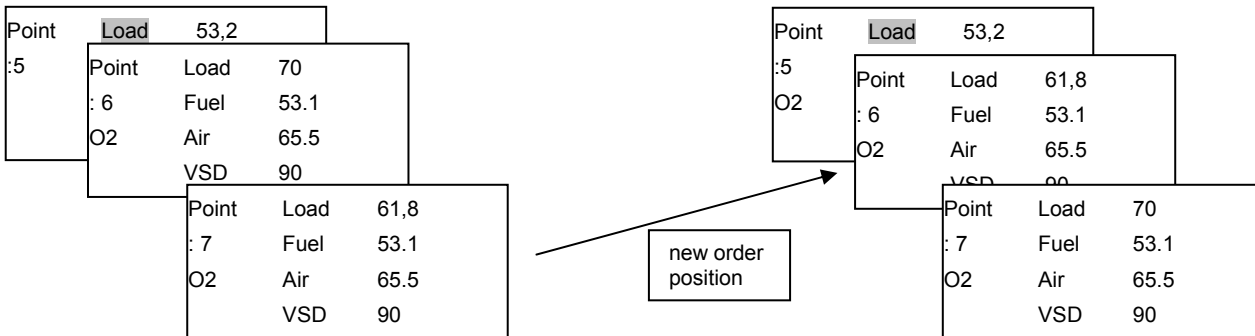



ATTENTION: When % load value is changed by user, LMV recalculates all the curve-points according the new load value. It may happen that the point you are adjusting, once saved, is moved to another position.



10 Configurations for burner with FGR

10.1 Recommendations

	<p>Note! Reduction of maximum burner output Use of the flue gas recirculation (FGR) function or the flue gas mass introduced to the supply air duct might lower the burner's maximum output. This means that the maximum amount of combustion air that can be introduced will be reduced. It is recommended to consider a proper air excess during the regulation of the burner in order to have to the right O2 content in the smoke, after the flue gas recirculation. Hence, the amount of fuel for high-fire operation must be reduced to ensure correct combustion values.</p>
	<p>Caution! Temperature-compensated flue gas recirculation (FGR) can be correctly set only when selecting with <i>DriveLowfire</i> in operation! A change in the curve point without the corresponding flue gas recirculation temperature (e.g. <i>without driving</i> in operation or in standby) results in an incorrect <i>pairing</i> of the values <i>Flue gas recirculation position</i> and <i>Flue gas recirculation temperature</i>. This can lead to excessive amounts of recirculated flue gas, which might cause the flame to lift: <i>Stability limit of flame</i>.</p>
	<p>Caution! A subsequent change of the curve point without an associated flue gas recirculation (FGR) temperature (e.g. without <i>DriveLowfire</i> in operation or standby) leads to an incorrect pairing of <i>flue gas recirculation-position</i> and <i>flue gas recirculation-temperature</i>. This can lead to excessive amounts of recirculated flue gas, which might cause the flame to lift: <i>Stability limit of flame</i>.</p>
	<p>Note! Flue gas recirculation (FGR) in combination with O2 trim control Recommendation: Do not use flue gas recirculation (FGR) in combination with O2 trim control. This has no impact on the use of the O2 alarm. The physical effects are the following: 1. Pressures have reciprocal effects. 2. The reduction of O2 can lead to a significant increase of NOx levels. As a result of these reciprocal effects, it is difficult, if not impossible, to adjust fuel-air ratio control, O2 trim control, and the flue gas recirculation (FGR) function. Even if an adjustment was possible, the flame may become unstable during operation, or the required NOx levels might not be reached.</p>
	<p>Note! The full scope of setting <i>TCautoDeact</i> is possible only when the flue gas temperature is acquired via the load controller input (X60...). When the temperature is acquired via the PLL52... input (X86...) and the O2 trim controller / alarm is active (not <i>CtrlAutoDeac</i>), flue gas recirculation (FGR) mode <i>temperature-compensated</i> cannot be used (would lead to error <i>C:F6 D:2</i>). When operating mode <i>O2 Control</i> is deactivated (<i>man deact</i>), operating mode <i>TCautoDeact</i> can be used if the flue gas temperature is acquired via PLL52... (X86...).</p>
	<p>Attention! If at an dual-fuel burner the FGR function is used for only one fuel (e.g. gas operation with FGR and oil operation without FGR) pay attention to the following: When the fuel selection is switched over to the fuel without FGR it must be assured that the FGR actuator is closed and is supervised kept in the closed position. This is accomplished by making the following settings for the fuel without FGR: - Activation of the AUX3 actuator - Parameterization of the positions Home, Prepurge , Ignition and Postpurge to <i>closed</i> - Parameterization of all AUX3 actuator positions at all curve points to <i>closed</i> - Parameterization of the FGR operating mode to <i>Aux3onCurve</i></p>

Before to activate the FGR system, it is mandatory to complete the air/fuel ratio curve for each point, up to the maximum burned output.

Check the previous chapter for instructions.



	<p>WARNING: Activating or increasing the FGR butterfly valve opening, it is mandatory to check the combustion by means a properly and calibrated smoke analyzer.</p>
--	---

10.2 Address and activate the AUX3 servomotor.









Usually these operations are already set in the manufacturer factory.

They would be necessary in some cases as: the substitution of the servomotor, in case the FGR mode were not activated yet or the LMV5x were be supplied loose...



	WARNING: for LMV52.400 device, in case of FGR servomotor addressing: the only possible choice is AuxActuator3. Don't set the FGR servomotor for a different one.
--	---

1st level	2nd level	3rd level	4th level	5th level	6th level	Description
Params & Display						
	Actuators					Parameter settings for fuel/ air ratio control
		Addressing				Parameter settings for firing on Gas or on Oil
			AirActuator GasActuat OilActuat AuxActuator AuxActuator 2 AuxActuator 3		AuxActuator 3	AuxActuator 3 MUST be chosen

After the addressing, activate the FGR servomotor.

1st level	2nd level	3rd level	4th level	5th level	6th level	Description
Params & Display						
	RatioControl					Parameter settings for fuel/ air ratio control
		GasSettings OilSettings				Parameter settings for firing on Gas or on Oil
			AuxActuator	deactivated damper act VSD active AUX3 VSD+Aux3	Deactivated for LMV52.xxx AUX3 for LMV51.300	Deactivated for LMV52.xxx AUX3 for LMV51.300
			AirActuator	deactivated activated air influen	activated	
			AuxActuator 1			
			AuxActuator 2			
			AuxActuator 3		Activated for LMV52.xxx	
			VSD			
			GasActuator OilActuator		Activated Activated	Choice according to the Operation mode gas setting or oil setting.

10.3 Setting the special positions



1st level	2nd level	3rd level	4th level	5th level	6th level	Description
Param & Display						
	RatioControl					
		GasSettings OilSettings				
			SpecialPosition			

Suggested positions are below. They can be modify during the commissioning according to right needs.



Special Position: AUX3 POS

- Home position 0° (Closed)
- Prepurge position 90° (Open)
- Ignition position 0° (Closed)
- Postpurge position 90° (Open)

10.4 Setting the load controller mode: see the previous chapter (regolazione senza FGR)

	WARNING: If one of the intLC (internal Load Controller) option must be choice, a temperature sensor cannot be connected to the terminal X60. A temperature sensor with analogue output or a converter Ohm → mA or V must be used. They must be connected to the terminals X61.
	WARNING: If one of the extLC (External Load Controller) options must be used, set "no sensor", "Temperature sensor" or "Pressure Sensor" on the choice for the modulation probe.
	WARNING: The X61 door must be configured in according to the used sensor or signal.

10.5 FGR mode choice

1st level	2nd level	3rd level	4th level	5th level	6th level	Description
Param & Display						
	Flue Gas Recirc					
		FGR-Mode 	AUX3onCurve time temperature temp. contr. TCautoDeact deactMinpos auto deact			According to the preference and instruction in the table below.

Description of the FGR mode.

FGR-Mode	Description	LMV50 LMV51.3 LMV52.2	LMV52.4..
Aux3onCurve	Flue gas recirculation (FGR) function is deactivated. Auxiliary actuator 3 is driven along its parameterized ratio control curve	●	●
deactivated	After the ignition position, auxiliary actuator 3 is always held at the minimum position for flue gas recirculation (indicated with #) and the flue gas recirculation temperature is not evaluated (display XXX). This ensures that the system is operated in a safe state if the flue gas recirculation setting could not be fully realized. We recommend performing burner start-up using this setting prior to setting the flue gas recirculation curve		●
time	Auxiliary actuator 3 maintains the ignition position until an adjustable time is reached (parameter "DelaytimeFGR..."). During the operation, the burner regulate its load as per the set curve points, without flue gas recirculation.	●	●
temperature	Auxiliary actuator 3 maintains the ignition position until an adjustable temperature is reached (parameter "FRG On Temp ..."). During the operation, the burner regulate its load as per the set curve points, without flue gas recirculation.	●	●
temp.contr.	The position of auxiliary actuator 3 is determined depending on the flue gas temperature and the ratio control curve. In addition, the actuator can maintain the ignition position until an adjustable time (parameter FGR On Time ...) is reached		●
TCautoDeact	Same manner of operation as temp.contr., but the function is automatically deactivated should the flue gas sensor become faulty. The actuator is driven to the minimum flue gas recirculation (FGR) position and a warning is issued		●
deactMinpos	After the ignition position, auxiliary actuator 3 always maintains the minimum flue gas recirculation (FGR) position (indicated by #) and the flue gas recirculation (FGR) temperature is not evaluated (display of XXX). The system can thus be driven to a secure state, if it was not possible to fully complete the flue gas recirculation (FGR) settings. It is recommended to use this setting for commissioning the burner before adjusting the flue gas recirculation (FGR) curve		
auto deact	Flue gas recirculation (FGR) with temperature compensation was automatically deactivated. Same operation mode as deactMinpos, but a warning is issued		●

10.6 Main parameter of the FGR function

Parameter	Description	LMV50 LMV51.3 LMV52.2	LMV52.4..
DelaytimeFGR Gas DelaytimeFGR Oil	Setting of delay time for auxiliary actuator 3 to be kept in the ignition position after entering phase <i>OPERATION</i>	●	●
ThresholdFGR Gas ThresholdFGR Oil	Setting of temperature that must not be exceeded so that auxiliary actuator 3 can be kept in the ignition position	●	
<i>FGR-sensor</i> (X86 PtNi1000 / X60 Pt1000 / X60 Ni1000)	Selection of temperature sensors for temperature-compensated flue gas recirculation (FGR)	●	●
<i>Factor FGR Gas</i> <i>Factor FGR Oil</i>	Readjustment of calculated temperature-dependent position of auxiliary actuator 3. The setting is made in steps of 1%. 100% means no readjustment. Settings <100% reduce the amount of recirculate flue gas (moving the damper toward the fully closed position). The factor has an impact only when there is a deviation from the learned flue gas recirculation (FGR) temperature. This means that when reaching the initially acquired flue gas recirculation (FGR) temperature, the stored position is approached, independent of the flue gas recirculation (FGR) factor. See the <i>Examples of tables showing the damper positions with FGR</i>		●
<i>FGR MinPos</i>	Minimum limitation of position of auxiliary actuator 3 for <i>temp.comp.</i> and <i>TCautoDeact</i> modes. The setting is made as an absolute value and ensures that flue gas recirculation (FGR) always operates with at least a minimum amount of flue gas. The position is also used to ensure a defined damper position for emergency operation or automatically deactivated flue gas recirculation (FGR)		●
<i>FGR MaxPos Fact</i>	Maximum limitation of the required position of auxiliary actuator 3 calculated from the current temperature and the warm position. The setting is made in steps of 1% and refers to the relevant curve-point. Interpolation between the curve-points is linear		●

The parameter are in side the AZL menu with following structure:

1st level	2nd level	3rd level	4th level	5th level	6th level	Description
Param & Display						
	Flue Gas Recirc					
		FGR-sensor	X60 Pt1000 X60 Ni1000			According to the available probe
		ThresholdFGR Gas ThresholdFGR Oil	0...850 °C			According to the regulation needs
		DelaytimeFGR Gas DelaytimeFGR Oil	0...63 min			According to the regulation needs
		Factor FGR Gas Factor FGR Oil	10..100%			According to the regulation needs
		FGR MinPos				According to the regulation needs
		FGR MaxPos Fact	0..100%			According to the regulation needs

	<p>WARNING: Only in case of FGR temperature compensation function.</p> <p>If the detected temperature value is lower than the value recorded during the curve setting, the AUX3 servomotor doesn't reach the set position, but it will be closer. In this condition flue gas recirculation flow could be not sufficient or too much.</p> <p>NOx value could be different from the expected or the flame could be instable. Try to reduce the correction factor ("Factor FGR Gas" or "Factor FGR Oil"). In case readjust the FGR curve. Probably the point was saved also if the flue gas temperature were too far from the regime condition.</p>
--	---

10.7 Example of FGR factor and FGR Maps Factor on the burner regulation.

We consider to set the AUX3 for FGR with the "temp.contr." Mode

The curve is as per the below table.

Point	1	2	3	4	Note
Load %	37,5 %	62,5 %	75 %	100 %	
AUX3 FGR Curve	19,3 °	25,0 °	28,5 °	37,0 °	
FGR temperature	72 °C	105 °C	121 °C	150 °C	The flue gas value increase from low to high flame. The temperature is with burner in operative condition.

LMV52.400 will calculate a "Zero Curve" referred to flue gas 0°C temperature.

The "Zero Curve" is calculated in reference to the effect of the temperature on the smoke density.

If "FGR factor" is set at 100% LMV will not make any additional correction.

Point	1	2	3	4	Note
Pos. FGR con T = 0 °C zero curve	15 °C	18 °C	19,7 °C	23,8 °C	FGR Factor set on 100%

If "FGR factor" is set at lower value than 100% LMV will apply an additional correction to calculate the "Zero Curve".

If "FGR factor" is 50%, the new "zero Curve" will be

Point	1	2	3	4	Note
Pos. FGR con T = 0 °C zero curve	7,6 °	9,0 °	9,8 °	11,9 °	FGR Factor set on 50% The above example shows that – with the zero curve – a flue gas recirculation (FGR) factor of 50% leads to a 50% reduction of the damper positions.

If the temperature value of the smoke during the operation of the burner is higher than the temperature value during the commissioning, the AUX3 position will be bigger than the set values.

To avoid a wide opening of the FGR butterfly valve it could be necessary to limit the automatic correction LMV52.400.

This could be necessary if the AUX3 opening become bigger than 90°, if a flame instability happen, or the flue gas recirculation is too big...

To limit the correction due to a higher temperature value, it become necessary to set the parameter "FGR MaxPOS Factor".

Point	1	2	3	4	Note
Pos. FGR	21,2 °	27,5 °	31,4 °	40,7 °	FGR MaxPOS Factor set on 10% I valori sono il 10% in più rispetto ai corrispondenti settati inizialmente.

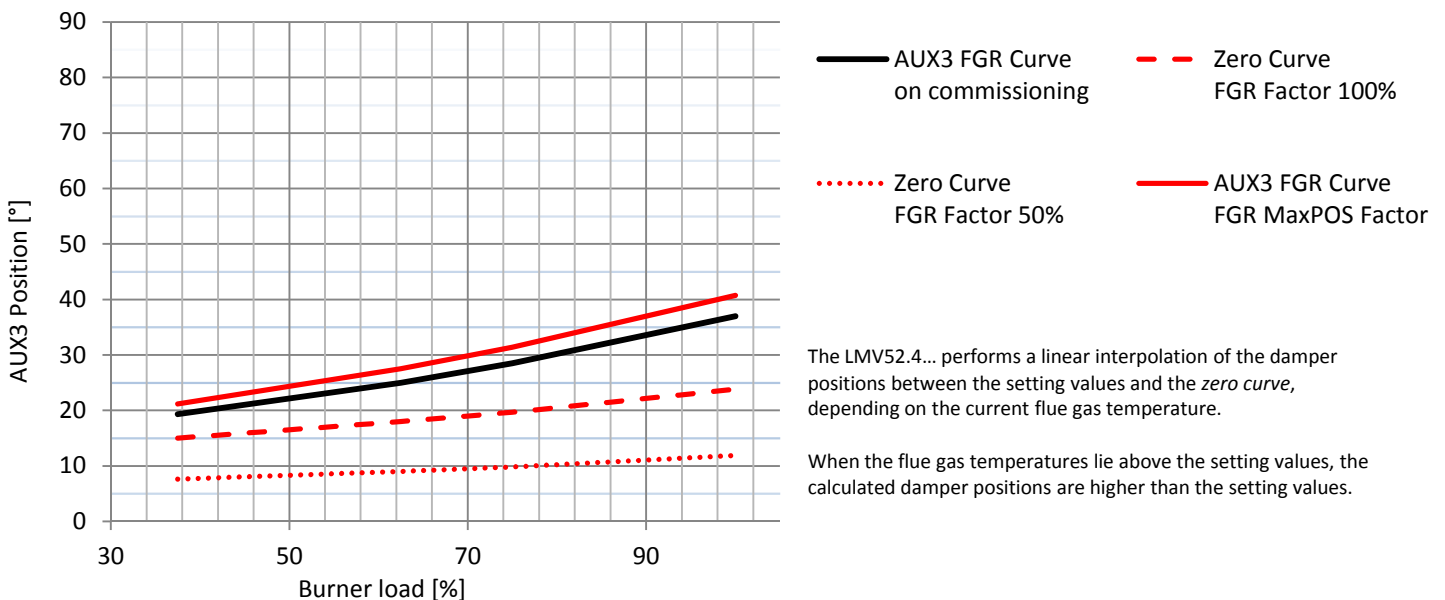

11 Cold start thermal shock (CSTP)

If there is a steam boiler or a boiler that must start up cold in the plant and to avoid thermal shocks a slow heating is required for the boiler by maintaining the burner at the minimum output, the automatic function "Cold start thermal shock" can be performed instead of the manual operation at minimum load.

The CSTP (Cold Start Thermal Schock) function can be enabled by the Technical service only (access by reserved password). if this function is enabled, when the burner starts up the "Thermal shock protection activated" message will be shown.

If this function is not enabled, after start-up, the burner will rapidly increase the load according to the requested value.

The CSTP function is a Service level parameter, to enable this function proceed as follows:

1st level	2nd level	3rd level	4th level	5th level	6th level	Description
Params & Display						Menu level for making the parameter settings
	LoadController					Settings for the internal load controller
		ColdStart				Settings for the cold start (thermal shock protection)
			ColdStartOn	Deactivated Activated		The parameter ColdStartOn deactivates or activates the Cold start protection function, the other parameters are factory set and can be changed following the next programming rows (see diagram)
			ThresholdOn	0...100%Wcurrent	20%	
			StageLoad	0..100%	15%	
			StageSetp_ Mod	1...100% Wcurrent	5%	
			Stage- Setp_Stage	1...100% Wcurrent	5%	
			MaxTme- Mod	1...63 min	3 min	
			MaxTmeStage	1...63 min	3 min	Cold start thermal shock protection, maximum time per step (multistage)
			ThresholdOff	1...100% Wcurrent	80%	Cold start thermal shock protection deactivation level referred to the current set-point (Wcurrent)
			Additional-Sens	Deactivated Pt100 Pt1000 Ni1000	Deactivated	Select extra sensor for cold start thermal shock protection
			Temp Cold- Start	0...2000 °C		Display of temperature acquired by extra sensor for the cold start thermal shock protection function
			Setpoint AddSensor	0...450 °C	60°C	Set-point for extra sensor for cold start thermal shock protection
			Release Stages	no release/ release	release	Cold start thermal shock protection load step stage mode (multistage operation)
			MaxTmeStage	1...63 min	3 min	Cold start thermal shock protection, maximum time per step (multistage)
			ThresholdOff	1...100% Wcurrent	80%	Cold start thermal shock protection deactivation level referred to the current set-point (Wcurrent)
			AdditionalSens	deactivated Pt100 Pt1000 Ni1000	deactivated	Select extra sensor for cold start thermal shock protection
			Temp Cold- Start	0...2000 °C		Display of temperature acquired by extra sensor for the cold start thermal shock protection function
			Setpoint Add- Sensor	0...450 °C	60 °C	Set-point for extra sensor for cold start thermal shock protection
			Release Stages	no release/ release	release	Cold start thermal shock protection load step stage mode (multistage operation)

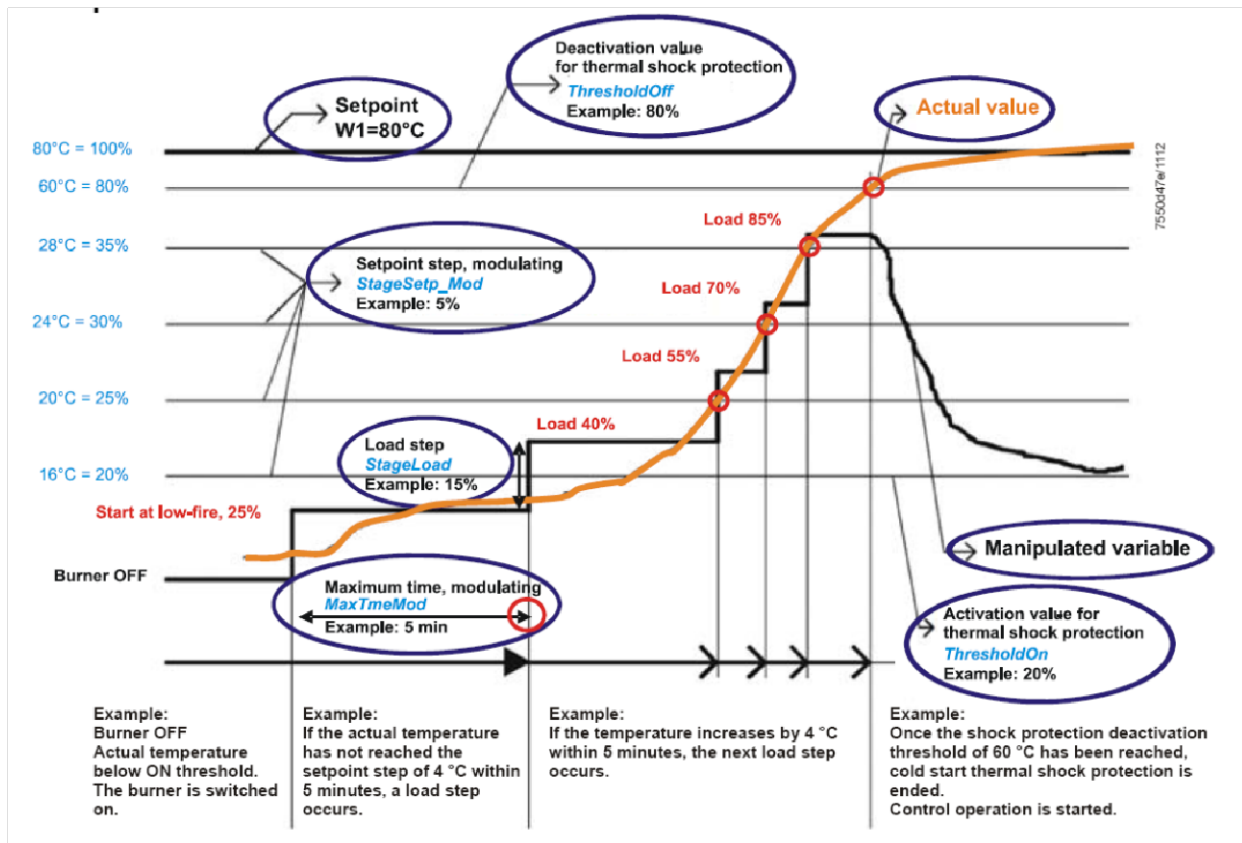



Note: by enabling the manual operation (this function can be set at user level also -see chapter "manual operation") the CSTP function is momentary excluded, when enabling the automatic operation again, the CSTP function (previously set at Service level) will be enabled as well.

12 BURNER MANUAL OPERATION



The operator can decide if choosing burner manual operation at a settable fixed load or modulating operation through the automatic load controller, then can also set the burner shutdown by means of the "burner off" function.

Choose the type of operation (Au-tom / Manual / Off).

1st level	2nd level	3rd level	Password	Description
ManualOpe- ration				Menu level for activating manual operation with the preselected load
	Au-tom/ Manual/Off			Selection of manual or automatic operation
		Automatic/ Burner on / Burner off	User	

Setting the load percentage for the manual operation

To set the load percentage at which the burner must operate in manual mode, proceed as described below.

1st level	2nd level	3rd level	Password	Description
ManualOpe- ration				Menu level for activating manual operation with the preselected load
	SetLoad			Set target load
		0..100%	User	

**LMV51.300B2 / LMV52.200B1 / LMV52.200B2 /
LMV52.240B2**

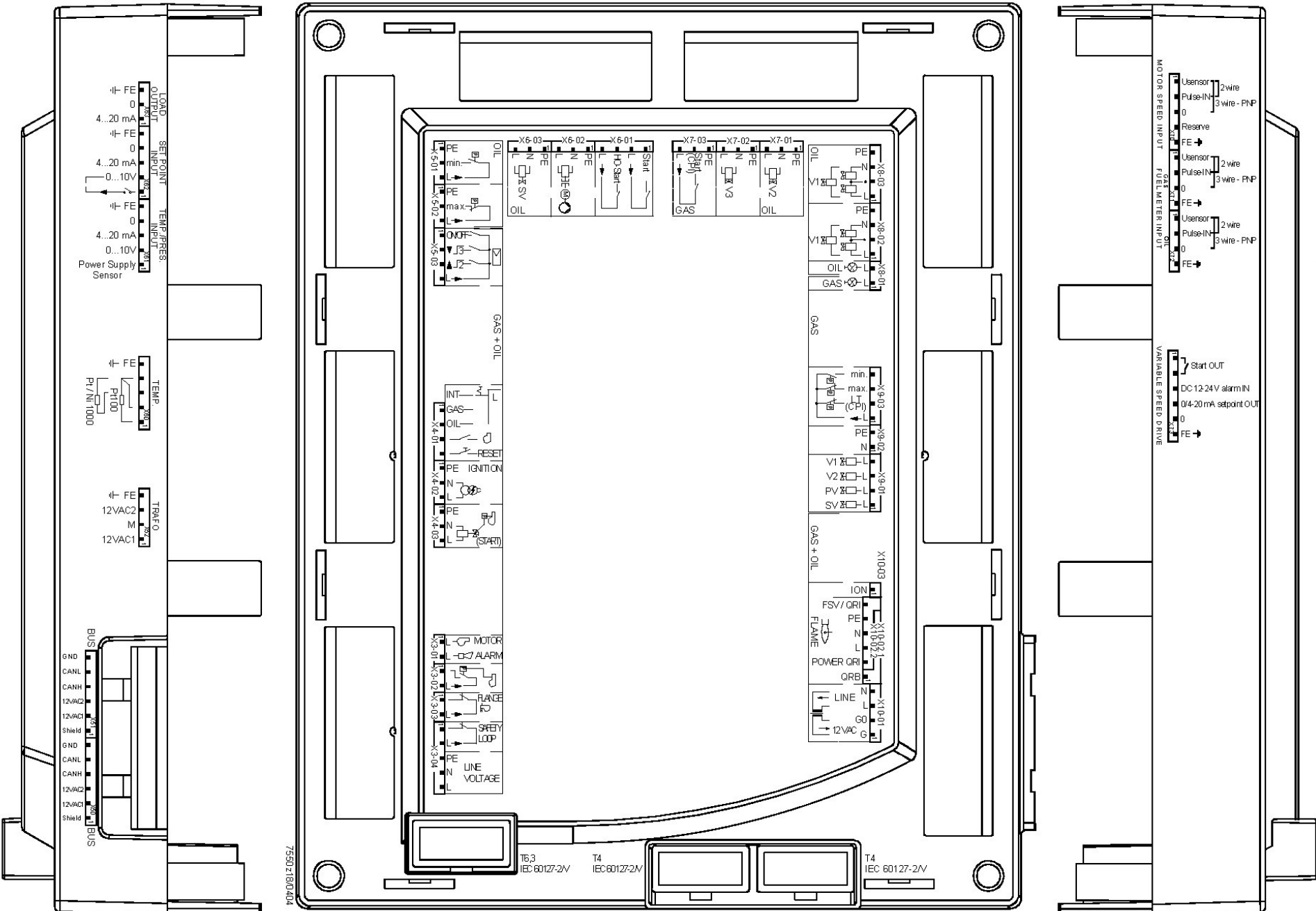

75502180404

Terminal group	Connection symbol		Input	Output	Description of connection terminals	Electrical rating
X3-01	PIN1			x	Fan motor contactor	AC 230 V +10 % / -15 %, 50...60 Hz, 1 A, cos.0.4
	PIN2			x	Alarm	AC 230 V +10 % / -15 %, 50...60 Hz, 1 A, cos.0.4
X3-02	PIN1		x		Air pressure switch (LP)	AC 230 V +10 % / -15 %, 50...60 Hz, I _{max} 1.5 mA
	PIN2			x	Power signal for air pressure switch (LP)	AC 230 V +10 % / -15 %, 50...60 Hz, I _{max} 500 mA
X3-03	PIN1		x		End switch burner flange	AC 230 V +10 % / -15 %, 50...60 Hz, I _{max} 5 A
	PIN2			x	Power signal for end switch burner flange	AC 230 V +10 % / -15 %, 50...60 Hz, I _{max} 5 A
X3-04	PIN1		x		Safety loop	AC 230 V +10 % / -15 %, 50...60 Hz, I _{max} 5 A
	PIN2			x	Power signal for safety loop	AC 230 V +10 % / -15 %, 50...60 Hz, I _{max} 5 A
	PIN3			x	Protective earth (PE)	
	PIN4			x	Supply voltage neutral conductor (N)	
	PIN5			x	Supply voltage live conductor (L)	AC 230 V +10 % / -15 %, 50...60 Hz, fuse 6.3 AT (DIN EN 60 127 2 / 5)
X4-01					Fuel selection "internal" if pin 1-2 is not used	
	PIN1		x		Fuel selection gas	AC 230 V +10 % / -15 %, 50...60 Hz, I _{max} 1.5 mA
	PIN2		x		Fuel selection oil	AC 230 V +10 % / -15 %, 50...60 Hz, I _{max} 1.5 mA
	PIN3		x		Fan contactor contact (FCC) or flue gas recirculation pressure switch	AC 230 V +10 % / -15 %, 50...60 Hz, I _{max} 1.5 mA
	PIN4		x		Reset / manual lockout	AC 230 V +10 % / -15 %, 50...60 Hz, I _{max} 1.5 mA
X4-02	PIN1			x	Protective earth (PE)	
	PIN2			x	Neutral conductor (N)	
	PIN3			x	Ignition	AC 230 V +10 % / -15 %, 50...60 Hz, 2 A, cos.0.2
X4-03	PIN1			x	Protective earth (PE)	
	PIN2			x	Neutral conductor (N)	
	PIN3			x	Start signal or pressure switch relief (air pressure switch test valve)	AC 230 V +10 % / -15 %, 50...60 Hz, 0.5 A, cos.0.4

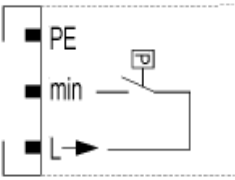
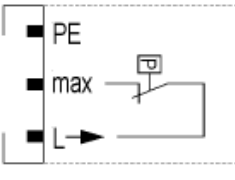
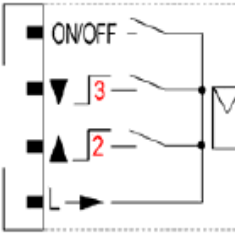
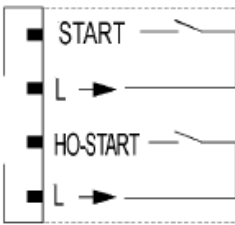
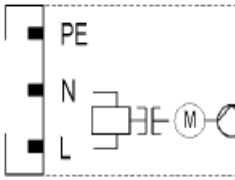
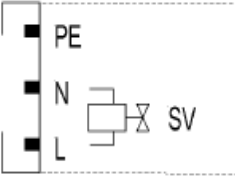
Terminal group	Connection symbol		Input	Output	Description of connection terminals	Electrical rating
X5-01	PIN1			x	Protective earth (PE)	
	PIN2		x		Pressure switch min-oil (DWmin-oil)	AC 230 V +10 % / -15 %, 50...60 Hz, I _{max} 1.5 mA
	PIN3			x	Power signal for pressure switch-min-oil (DWmin-oil)	AC 230 V +10 % / -15 %, 50...60 Hz, I _{max} 500 mA
X5-02	PIN1			x	Protective earth (PE)	
	PIN2		x		Pressure switch-max-oil (DWmax-oil)	AC 230 V +10 % / -15 %, 50...60 Hz, I _{max} 1.5 mA
	PIN3			x	Power signal for pressure switch-max-oil (DWmax-oil)	AC 230 V +10 % / -15 %, 50...60 Hz, I _{max} 500 mA
X5-03	PIN1		x		Controller (ON / OFF)	AC 230 V +10 % / -15 %, 50...60 Hz, I _{max} 1.5 mA
	PIN2		x		Controller closes / stage 3	AC 230 V +10 % / -15 %, 50...60 Hz, I _{max} 1.5 mA
	PIN3		x		Controller opens / stage 2	AC 230 V +10 % / -15 %, 50...60 Hz, I _{max} 1.5 mA
	PIN4			x	Power signal for control of controller	AC 230 V +10 % / -15 %, 50...60 Hz, I _{max} 500 mA
X6-01	PIN1		x		Start release oil	AC 230 V +10 % / -15 %, 50...60 Hz, I _{max} 1.5 mA
	PIN2			x	Power signal start release oil	AC 230 V +10 % / -15 %, 50...60 Hz, I _{max} 500 mA
	PIN3		x		Direct heavy oil start	AC 230 V +10 % / -15 %, 50...60 Hz, I _{max} 1.5 mA
	PIN4			x	Power signal direct heavy oil start	AC 230 V +10 % / -15 %, 50...60 Hz, I _{max} 500 mA
X6-02	PIN1			x	Protective earth (PE)	
	PIN2			x	Neutral conductor (N)	
	PIN3			x	Oil pump / magnetic coupling	AC 230 V +10 % / -15 %, 50...60 Hz, 2 A, cos.0.4
X6-03	PIN1			x	Protective earth (PE)	
	PIN2			x	Neutral conductor (N)	
	PIN3				Fuel valve (shutoff valve-oil)	AC 230 V +10 % / -15 %, 50...60 Hz, 1 A, cos.0.4

Terminal group	Connection symbol		Input	Output	Description of connection terminals	Electrical rating
X7-01	PIN1			x	Protective earth (PE)	
	PIN2			x	Neutral conductor (N)	
	PIN3				Fuel valve 2 (oil)	AC 230 V +10 % / -15 %, 50...60 Hz, 1 A, cos.0.4
X7-02	PIN1			x	Protective earth (PE)	
	PIN2			x	Neutral conductor (N)	
	PIN3				Fuel valve 3 (oil)	AC 230 V +10 % / -15 %, 50...60 Hz, 1 A, cos.0.4
X7-03	PIN1			x	Protective earth (PE)	
	PIN2		x		Start release gas CPL (LMV52...)	AC 230 V +10 % / -15 %, 50...60 Hz, I _{max} 1.5 mA
	PIN3			x	Power signal (reserve)	AC 230 V +10 % / -15 %, 50...60 Hz, I _{max} 500 mA

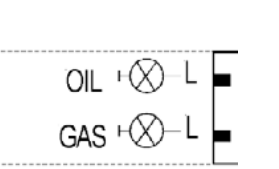
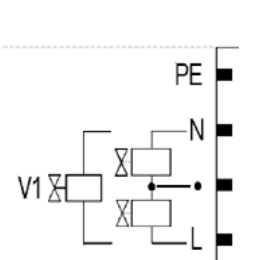
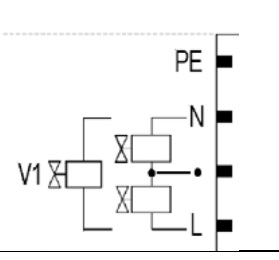
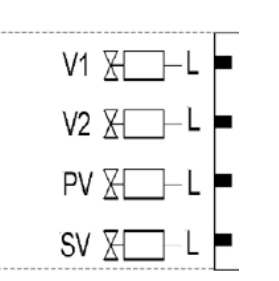
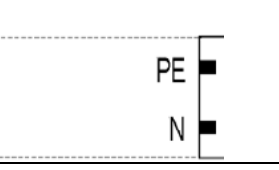
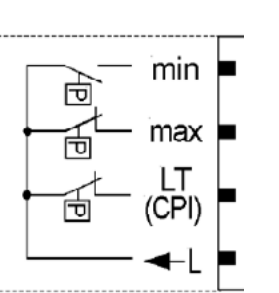
Terminal group	Connection symbol	Input	Output	Description of connection terminals	Electrical rating
X8-01		PIN2	x	Firing on oil	AC 230 V +10 % / -15 %, 50...60 Hz, 1 A, cos.0.4
		PIN1	x	Firing on gas	AC 230 V +10 % / -15 %, 50...60 Hz, 1 A, cos.0.4
X8-02		PIN4	x	Protective earth (PE)	
		PIN3	x	Neutral conductor (N)	
		PIN2	x	Wiring point for valves connected in series	
		PIN1	x	Fuel valve 1 (oil)	AC 230 V +10 % / -15 %, 50...60 Hz, 1 A, cos.0.4
X8-03		PIN4	x	Protective earth (PE)	
		PIN3	x	Neutral conductor (N)	
		PIN2	x	Wiring point for valves connected in series	
		PIN1	x	Fuel valve 1 (oil)	AC 230 V +10 % / -15 %, 50...60 Hz, 1 A, cos.0.4
X9-01		PIN4	x	Fuel valve 1 (gas)	AC 230 V +10 % / -15 %, 50...60 Hz, 2 A, cos.0.4
		PIN3	x	Fuel valve 2 (gas)	AC 230 V +10 % / -15 %, 50...60 Hz, 2 A, cos.0.4
		PIN2	x	Fuel valve (gas)	AC 230 V +10 % / -15 %, 50...60 Hz, 2 A, cos.0.4
		PIN1	x	Fuel valve (shutoff valve-(gas))	AC 230 V +10 % / -15 %, 50...60 Hz, 2 A, cos.0.4
X9-02		PIN2	x	Protective earth (PE)	
		PIN1	x	Neutral conductor (N)	
X9-03		PIN4	x	Pressure switch-min-gas, start release gas	AC 230 V +10 % / -15 %, 50...60 Hz, I _{max} 1.5 mA
		PIN3	x	Pressure switch-max-gas (DWmax-gas)	AC 230 V +10 % / -15 %, 50...60 Hz, I _{max} 1.5 mA
		PIN2	x	Pressure switch-valve proving-gas / leakage test or valve closing contact (CPI)	AC 230 V +10 % / -15 %, 50...60 Hz, I _{max} 1.5 mA
		PIN1	x	Power signal for pressure switch	AC 230 V +10 % / -15 %, 50...60 Hz, I _{max} 500 mA

Terminal group	Connection symbol		Input	Output	Description of connection terminals	Electrical rating
X10-01		PIN4		x	Neutral conductor (N)	AC 230 V +10 % / -15 %, 50...60 Hz, max 1 mA
		PIN3		x	Power signal transformer	
		PIN2	x		AC power signal GO	AC 12 V +10 % / -15 %, 50...60 Hz, max 1.2 mA
		PIN1	x		AC power signal fan motor (G)	
X10-02		PIN6	x		QRI... (IR detector) / QRA7... signal voltage	Umax DC 5 V
		PIN5		x	Protective earth (PE)	
		PIN4		x	Neutral conductor (N)	
		PIN3		x	Power signal	AC 230 V +10 % / -15 %, 50...60 Hz, I _{max} 500 mA
		PIN2		x	QRI... (IR detector) / QRA7... power supply	DC 14 / 21 V I _{max} 100 mA
		PIN1	x		QRB... signal voltage	Max. DC 8 V
X10-03		PIN1		x	Ionization probe (ION) (alternatively QRA2... / QRA4.U/QRA10..., refer to section <i>Description of inputs and outputs</i>)	Umax (X3-04-PINS) I _{max} 0.5 mA
X50		PIN6		x	Reference ground (PELV)	
		PIN5		x	Communication signal (CANL)	DC U <5 V, R _w = 120 Ω, level to ISO-DIS 11898
		PIN4		x	Communication signal (CANH)	
		PIN3		x	AC power supply for actuators / display and operating unit AZL5...	AC 12 V +10 % / -15 %, 50...60 Hz, Fuse max. 4 A
		PIN2		x	AC power supply for actuators / display and operating unit AZL5...	
		PIN1	x		Shield connection (functional earth)	
X51		PIN6		x	Reference ground (PELV)	
		PIN5		x	Communication signal (CANL)	DC U <5 V, R _w = 120 Ω, level to ISO-DIS 11898
		PIN4		x	Communication signal (CANH)	
		PIN3		x	AC power supply for actuators / display and operating unit AZL5...	AC 12 V +10 % / -15 %, 50...60 Hz, Fuse max. 4 A
		PIN2		x	AC power supply for actuators / display and operating unit AZL5...	
		PIN1	x		Shield connection (functional earth)	

X52		PIN4	x	(functional earth)	
		PIN3	x	AC power supply from transformer to LMV5... system	AC 12 V +10 % / -15 %, 50...60 Hz
		PIN2	x	Reference ground (PELV)	
		PIN1	x	AC power supply from transformer to LMV5... system	AC 12 V +10 % / -15 %, 50...60 Hz

Terminal group	Connection symbol	Input	Output	Description of connection terminals	Electrical rating
Temperature / pressure controller					
X60		PIN5	x	Functional earth for shield connection	
		PIN4	x	Reference ground	
		PIN3	x	Temperature sensor input Pt / LG- Ni 1000	
		PIN2	x	Line compensation temperature sensor PT100	
		PIN1	x	Temperature sensor input PT100	
X61		PIN5	x	Functional earth for shield connection	
		PIN4	x	Reference ground	
		PIN3	x	Current input for temperature / pressure signal 0/4...20 mA	DC 0/4...20 mA
		PIN2	x	Voltage input for temperature / pressure signal DC 0...10 V	DC 0...10 V
		PIN1	x	Power supply for temperature / pressure transmitter	approx. DC 20 V Max. 25 mA
X62		PIN5	x	Functional earth for shield connection	
		PIN4	x	Reference ground	
		PIN3	x	Current input for setpoint or load	DC 0...20 mA
		PIN2	x	Voltage input for setpoint or load	DC 0...10 V
		PIN1	x	Power supply for setpoint changeover	approx. DC 24 V Max. 2 mA
X63		PIN3	x	Functional earth for shield connection	
		PIN2	x	Reference ground	
		PIN1	x	Current output for burner (LOAD OUTPUT)	DC 4...20 mA, RLmax = 500 Ω

Note: Specifications and data subject to change. Errors and omissions excepted.

RECOMMENDATIONS FOR LMV5x CONNECTIONS

Connections affected by EMC noises are related to the bus cable (actuator line cable, PLL52), detection probe cable, speed sensor cable, 4-20mA signal cable that controls the VSD.

Input and power cables (400V e 230V) must be laid separately from the signal cables.

The bus cable between control panel and burner and between burner and PLL52 board (used when O2 trim control must be performed) must be laid separately and far from power cables.

When long cables must be provided, it is recommended to put the bus cable into a pipe or a metallic sheath: the sheath ends must be grounded with suitable rings.

Provide a shielded three-pole cable type FG7OH2R+T (see Annex 1), between VSD and motor; earth must be outside the shielding.

Shielding must get to the lower part of the VSD and get to the motor junction box. Shielding must be connected to the equipotential ground on both ends, better with suitable rings.

Otherwise, a standard cable can be used also but put inside a pipe or metallic sheath (the sheath ends must be grounded with suitable rings) and an earth external wire for the motor ground.

The cable for the 4÷20mA signal that controls the VSD, must be shielded, only LMV5x side ends connected to the equipotential terminal. If the VSD is not inside the control panel, the cable must be laid separately inside a metallic sheath earthed by means of rings.

As for the speed sensor cable and QRI detection probe cable, provide a "Ethernet " cat.5 or 6 cable, inside a metallic sheath (with ends earthed by means of rings) and laid separately from the motor cable.

As the sensor uses three wires, divide and twist the pairs to avoid noises. Alternatively, provide a 3x2x0,50 twisted cable Liycy type (see Annex 2).

In case of O2 trim control version, O2 probe and PLL52 board must be connected by means of a 3x2x0,50 twisted cable Liycy type (see Annex 2).

NB: when a shielding has both ends wired to Earth, be sure they are at the same potential. If there is any Voltage difference, ground just one of the two ones, generally the one closest to the weakest, respect to EMC, component. Anyway give way to the burner control, that is wire to ground the end of the shielding closest to the LMV. For instance, the cable between LMV and VSD, if the shielding has only one end wired to Earth, this one has to be the one LMV side.

Annex1 – Example for motor cable



FG70H2R+T 0,6/1 kV
A RIDOTTA EMISSIONE
DI ALOGENI

FG70H2R+T 0,6/1 kV
WITH REDUCED
HALOGEN EMISSION

INDUSTRIA E AUTOMAZIONE



CARATTERISTICHE TECNICHE

Colore delle anime:		UNEL 00722 / VDE 0293 (Tab. 8)
Conduttori:	rame rosso elettrolitico	normativa CEI EN 60228 Cl.5 (Tabella 9)
Isolante:	elastomero silanico di qualità G7	normativa CEI 20-11 - CEI EN 50363
Separatore:	nastro poliestere-mylar	
Schermatura:	a treccia capillari di rame rosso elettrolitico cop. > 80 %	
Guaina esterna:	PVC di qualità TM2	normativa CEI 20-11 - CEI EN 50363
Colore della guaina:	Grigio RAL 7035	
Prova N.P. verticale:	su singolo conduttore o cavo isolato	normativa CEI EN 60332-1-2
Prova GAS emessi:	durante la combustione	normativa CEI EN 50267-2-1
Resistenza agli olii:		normativa CEI 20-34/O-1
Prova N.P.I.:		normativa CEI 20-22/2
Resistenza elettrica:	relativamente alla sezione	normativa CEI EN 60228 (Tabella 9)
Tens. nominale Uo/U:	0,6/1 kV	
Tensione di prova:	4000 V	
Temperatura d'esercizio:	(- 25 °C ÷ + 90 °C)	
Temperatura di corto circuito:	250 °C	
Marcatura:	BERICA CAVI S.P.A. (VI) FG70H2R + T 0,6/1 kV O.R. CEI 20-22 II CE Anno/Lotto - N° Anime x Sezione + T	
Raggio di curvatura:	minimo 15 volte diametro esterno	

TECHNICAL FEATURES

<i>Cores colour code:</i>		UNEL 00722 / VDE 0293 (Tab. 8)
<i>Conductors :</i>	<i>fine wires stranded of bare copper</i>	CEI EN 60228 Cl.5 (Tab.9) rule
<i>Insulation:</i>	<i>G7 quality rubber</i>	CEI 20-11 - CEI EN 50363 rules
<i>Assembling:</i>	<i>polyester-mylar tape</i>	
<i>Shield:</i>	<i>bare copper braid 80% covering</i>	
<i>Outer sheath:</i>	<i>TM2 quality PVC</i>	CEI 20-11 - CEI EN 50363 rules
<i>Sheath colour code:</i>	<i>Grey RAL 7035</i>	
<i>Vertical fire retardant test:</i>	<i>on single conductor or insulated cable</i>	CEI EN 60332-1-2 rule
<i>Emission GAS test:</i>	<i>during the combustion</i>	CEI EN 50267-2-1 rule
<i>Oil resistant test:</i>		CEI 20-34/O-1 rule
<i>Flame retardant test:</i>		CEI 20-22/2 rule
<i>Electric resistance:</i>	<i>according to</i>	CEI EN 60228 (Tab. 9)
<i>Working voltage:</i>	<i>0,6/1 kV</i>	
<i>Testing voltage:</i>	<i>4000 V</i>	
<i>Working temperature:</i>	<i>(-25 °C ÷ +90 °C)</i>	
<i>Short circuit temperature:</i>	<i>250 °C</i>	
<i>Outer printing:</i>	<i>BERICA CAVI S.P.A. (VI) FG70H2R + T 0,6/1 kV O.R. CEI 20-22 II CE - Year/Lot - Nr. of cond. by cross sect. + T.</i>	
<i>Bending radius:</i>	<i>cable outer diameter x 15</i>	

Annex 2 – Example for sensor cable

CAVI TIPO "Li-YCY-P" A COPPIE SCHERMATI A TRECCIA

IMPIEGO: Cavi schermati per segnali e trasmissione dati per applicazioni in elettronica ed informatica, efficaci contro le interferenze elettromagnetiche ed atti ad offrire una protezione contro influenze capacitive dovute a campi elettrici.

CABLES TYPE "Li-YCY-P" TWISTED PAIRS, TINNED COPPER BRAID SHIELD

STANDARD USE: Signal and data transmission shielded cables for electronics and information technology applications, effective against electromagnetic interferences and suited to offer protection against capacitive influences due to electric fields.

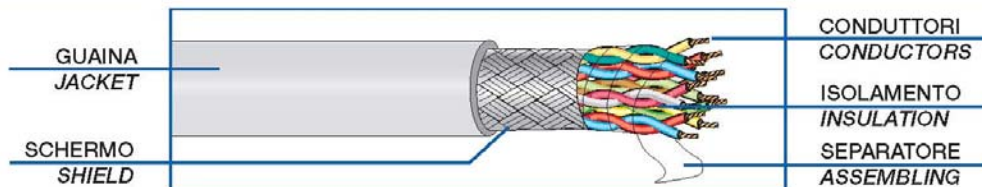

CARATTERISTICHE TECNICHE		TECHNICAL FEATURES
CONDUTTORI: Flessibili in rame rosso sec. CEI 20-29 (IEC 228) Cl. 5, VDE 0295 Cl. 5, NF C32-013 (0,34 mm ² : VDE 0295 Cl.2)		CONDUCTORS: Flexible bare copper conductors CEI 20-29 (IEC 228) Cl. 5, VDE 0295 Cl. 5, NF C32-013 Ref. (0,34 mm ² : VDE 0295 Cl.2)
ISOLANTE: Polivinilcloruro (PVC) Sec. CEI 20-11 Cl. R2, VDE 0207 Cl. Y12 Codici colori: a norma DIN 47100		INSULATION: Polyvinylchloride (PVC) CEI 20-11 Cl. R2, VDE 0207 Cl. Y12 Ref. Colour code according to DIN 47100
SEPARATORE: Nastro di poliestere		ASSEMBLING: Polyester tape helically wound
SCHERMATURA: A treccia di rame stagnato Cordina di continuità a richiesta		SHIELD: Tinned copper braid On request with drain wire
GUAINA ESTERNA: Polivinilcloruro (PVC) Sec. CEI 20-20 Cl. TM2, VDE 0207 Cl. YM2 colore: grigio (diverso a richiesta)		JACKET: Polyvinylchloride (PVC) CEI 20-20 Cl. TM2, VDE 0207 Cl. YM2 Ref. colour: grey or on request
RESISTENZA ELETTRICA DEI CONDUTTORI: 0,14 mm ² : <148 Ohm/Km 0,25 mm ² : <79 Ohm/Km 0,34 mm ² : <55 Ohm/Km 0,50 mm ² : <39 Ohm/Km 0,75 mm ² : <26 Ohm/Km 1mm ² : <19,5 Ohm/Km		ELECTRICAL CONDUCTOR RESISTANCE: 0,14 mm ² : <148 Ohm/Km 0,25 mm ² : <79 Ohm/Km 0,34 mm ² : <55 Ohm/Km 0,50 mm ² : <39 Ohm/Km 0,75 mm ² : <26 Ohm/Km 1 mm ² : <19,5 Ohm/Km
TEMPERATURA DI ESERCIZIO: posa fissa: -25°C + 70°C posa mobile: -15°C + 70°C		WORKING TEMPERATURE: fixed installation: -25°C + 70°C flexing: -15°C + 70°C
RAGGIO DI CURVATURA: 15 volte il diametro del cavo		BENDING RADIUS: 15 times overall diameter of cable
TENSIONE DI ESERCIZIO: 250 V		WORKING VOLTAGE: 250 V
TENSIONE DI PROVA: 1500 V		TEST VOLTAGE: 1500 V

CAVI TIPO "Li-YCY-P"
A COPPIE SCHERMATI A TRECCIA

CABLES TYPE "Li-YCY-P"
TWISTED PAIRS, TINNED COPPER BRAID SHIELD

PROVA N.P. FIAMMA:
Standard: sec. CEI 20-35 (IEC 332.1)
A richiesta: sec. CEI 20-22 II (IEC 332.3A)



FLAME RETARDANT TEST:
Standard: CEI 20-35 (IEC 332.1) Ref.
On request: CEI 20-22 II (IEC 332.3A) Ref.

IMPEDENZA DI TRASFERIMENTO:
max 200 mohm/m (f<10MHz)



SURFACE TRANSFER IMPEDANCE:
max 200 mohm/m (f<10MHz)

CAPACITA' DI LAVORO:
cond/cond: 120 nF/km (nom.)
cond/sch: 180 nF/km (nom.)



CAPACITANCE:
cond/cond: 120 nF/km (nom.)
cond/shield: 180 nF/km (nom.)

CODICE	FORMAZIONE	ø esterno medio	Peso medio Kg/Km	CODICE	FORMAZIONE	ø esterno medio	Peso medio Kg/Km
CODE	TYPE	outer diameter ø	Medium weight Kg/Km	CODE	TYPE	outer diameter ø	Medium weight Kg/Km
28.204.1.02.1.000	2x2x0.14	5.6	40.0	28.204.1.02.4.000	2x2x0.34	7.3	68.0
28.204.1.03.1.000	3x2x0.14	5.9	47.0	28.204.1.03.4.000	3x2x0.34	7.8	82.0
28.204.1.04.1.000	4x2x0.14	6.2	61.0	28.204.1.04.4.000	4x2x0.34	8.6	96.0
28.204.1.05.1.000	5x2x0.14	7.2	68.0	28.204.1.05.4.000	5x2x0.34	10.0	110.0
28.204.1.06.1.000	6x2x0.14	7.6	76.0	28.204.1.06.4.000	6x2x0.34	10.6	130.0
28.204.1.07.1.000	7x2x0.14	7.6	82.0	28.204.1.07.4.000	7x2x0.34	10.6	145.0
28.204.1.08.1.000	8x2x0.14	8.4	90.0	28.204.1.08.4.000	8x2x0.34	11.5	150.0
28.204.1.10.1.000	10x2x0.14	9.8	118.0	28.204.1.10.4.000	10x2x0.34	13.0	190.0
28.204.1.12.1.000	12x2x0.14	10.2	130.0	28.204.1.12.4.000	12x2x0.34	13.5	220.0
28.204.1.16.1.000	16x2x0.14	11.2	160.0	28.204.1.16.4.000	16x2x0.34	15.2	250.0
28.204.1.18.1.000	18x2x0.14	11.7	186.0	28.204.1.18.4.000	18x2x0.34	16.0	275.0
28.204.1.20.1.000	20x2x0.14	12.4	200.0	28.204.1.20.4.000	20x2x0.34	17.1	290.0
28.204.1.25.1.000	25x2x0.14	14.0	273.0	28.204.1.25.4.000	25x2x0.34	19.5	400.0
28.204.1.02.3.000	2x2x0.25	5.8	54.0	28.204.1.02.5.000	2x2x0.50	7.6	75.0
28.204.1.03.3.000	3x2x0.25	7.0	65.0	28.204.1.03.5.000	3x2x0.50	9.0	125.0
28.204.1.04.3.000	4x2x0.25	7.3	89.0	28.204.1.04.5.000	4x2x0.50	10.0	140.0
28.204.1.05.3.000	5x2x0.25	8.0	99.0	28.204.1.05.5.000	5x2x0.50	10.8	160.0
28.204.1.06.3.000	6x2x0.25	9.0	114.0	28.204.1.06.5.000	6x2x0.50	11.7	190.0
28.204.1.07.3.000	7x2x0.25	9.0	120.0	28.204.1.07.5.000	7x2x0.50	11.7	220.0
28.204.1.08.3.000	8x2x0.25	9.6	126.0	28.204.1.08.5.000	8x2x0.50	14.0	250.0
28.204.1.10.3.000	10x2x0.25	10.3	160.0	28.204.1.10.5.000	10x2x0.50	15.0	300.0
28.204.1.12.3.000	12x2x0.25	11.4	171.0	28.204.1.12.5.000	12x2x0.50	15.7	345.0
28.204.1.16.3.000	16x2x0.25	13.1	238.0	28.204.1.16.5.000	16x2x0.50	17.6	450.0
28.204.1.18.3.000	18x2x0.25	13.6	248.0				
28.204.1.20.3.000	20x2x0.25	14.2	275.0				
28.204.1.25.3.000	25x2x0.25	16.4	340.0				

CAVI TIPO "Li-YCY-P"
A COPPIE SCHERMATI A TRECCIA

CABLES TYPE "Li-YCY-P"
TWISTED PAIRS, TINNED COPPER BRAID SHIELD

CODICE	FORMAZIONE	ø esterno medio	Peso medio Kg/Km	CODICE	FORMAZIONE	ø esterno medio	Peso medio Kg/Km
CODE	TYPE	outer diameter ø	Medium weight Kg/Km	CODE	TYPE	outer diameter ø	Medium weight Kg/Km
28.204.1.02.6.000	2x2x0.75	8.6	103.0	28.204.1.02.7.000	2x2x1	9.4	122.0
28.204.1.03.6.000	3x2x0.75	9.0	128.0	28.204.1.03.7.000	3x2x1	11.5	179.0
28.204.1.04.6.000	4x2x0.75	10.6	167.0	28.204.1.04.7.000	4x2x1	12.8	237.0
28.204.1.05.6.000	5x2x0.75	12.0	215.0	28.204.1.05.7.000	5x2x1	13.8	297.0
28.204.1.06.6.000	6x2x0.75	12.8	240.0				
28.204.1.07.6.000	7x2x0.75	12.8	265.0				
28.204.1.08.6.000	8x2x0.75	14.6	306.0				
28.204.1.10.6.000	10x2x0.75	16.0	355.0				
28.204.1.12.6.000	12x2x0.75	17.0	405.0				
28.204.1.16.6.000	16x2x0.75	20.5	565.0				

Addendum 4: LMV52... with O2 trim control and O2 module

General

The LMV52... system is an extended LMV51... system. A special feature of the LMV52... is control of the residual oxygen content to increase the boiler's efficiency.

In addition to the features of the LMV51..., the LMV52... provides O2 trim control, control of a maximum of 6 actuators, control of a VSD, and acquisition of cumulated fuel consumption and current fuel throughput. The LMV52... system uses an O2 sensor (QGO20...), an external O2 module, and the standard components of the LMV51... system.

ATTENTION: for the proper burner adjustment, it is necessary to install a fuel meter for each burner.

The PLL... O2 module is a detached measuring module for the QGO20... sensor and for 2 temperature sensors (Pt1000 / LG-Ni 1000). The module communicates with the LMV52... via CAN bus.

The fuel meters must be connected directly to the fuel-related inputs of the basic unit. On the AZL5... display and operating unit, the individual consumption values can be read out and the meter readings can be reset.

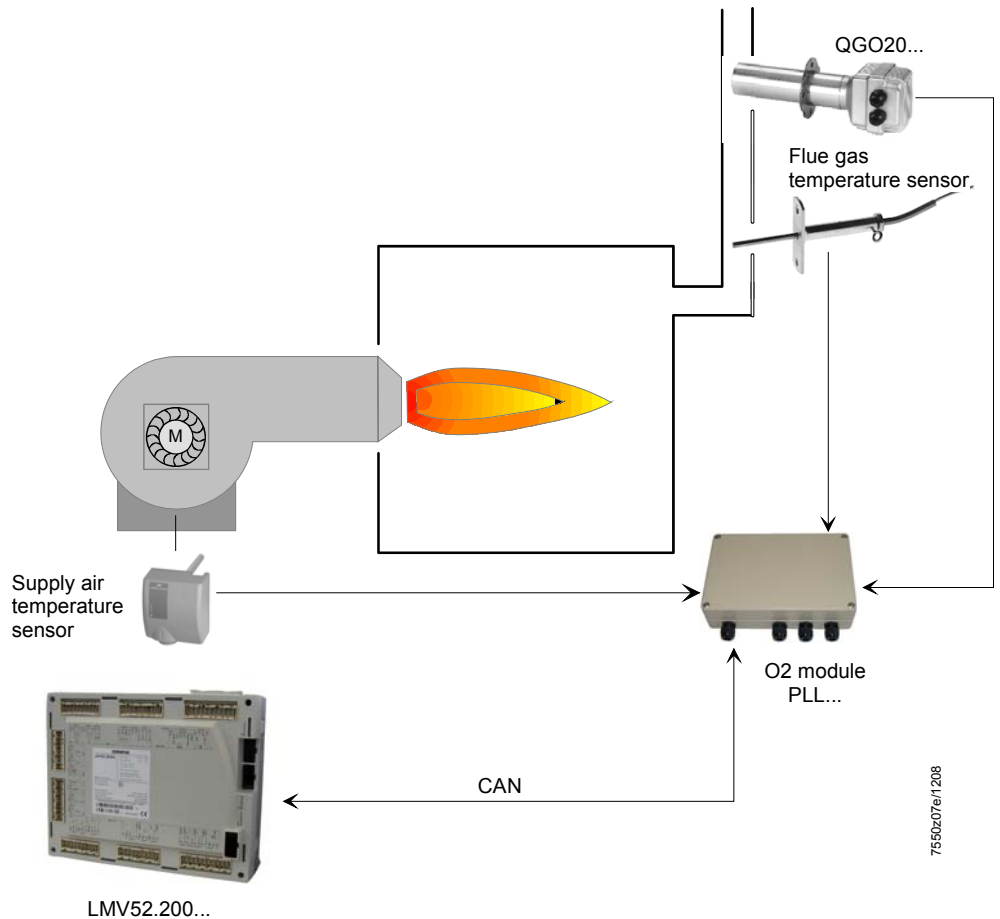

Determination of the maximum cable length

The maximum cable length between transformer and CAN bus users is dependent on the type of cable (cross-sectional area), the number of actuators and the type of actuator used (current).

The following graphs can be used to determine the maximum CAN bus cable lengths between the transformer and group of actuators or the AZL5..., depending on the relevant influencing factors.

The assumption was made that the actuators within the group are close to one another. The **minimum** cross-sectional area for the system examples shown results from the start of the curve.

The **maximum** cable lengths for the defined system cables AGG5.641 and AGG5.631 result from the points of intersection in the graph.

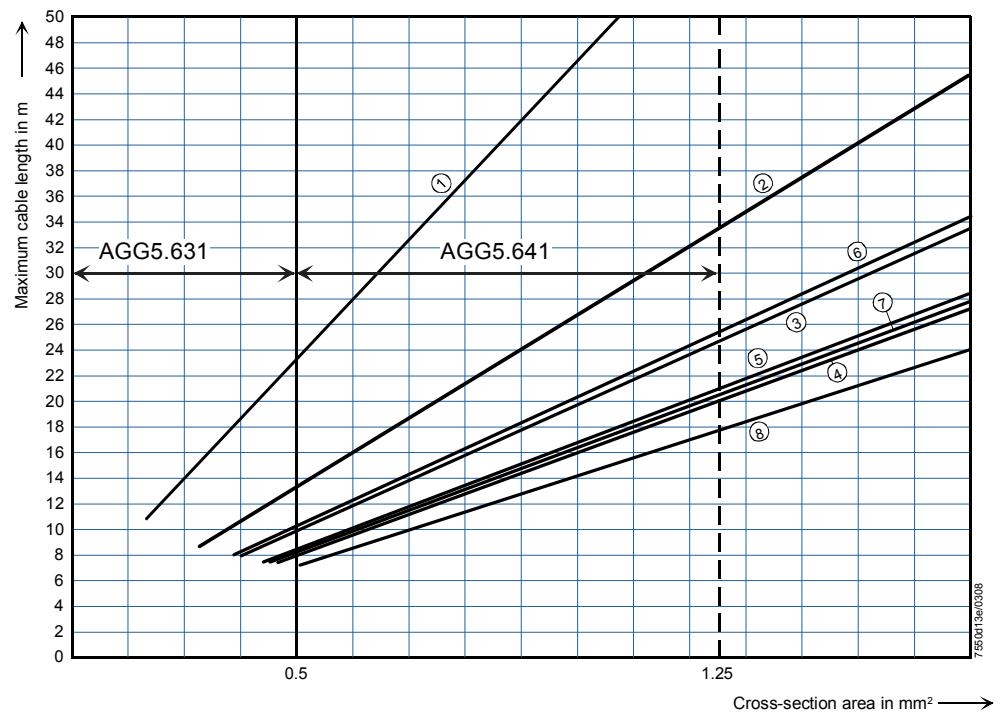

AGG5.631 (cable type 2)
AGG5.641 (cable type 1)

- | | |
|----------------|-------------------------------|
| ① 1 x SQM45... | ⑤ 2 x SQM48... |
| ② 2 x SQM45... | ⑥ 1 x SQM45... + 1 x SQM48... |
| ③ 3 x SQM45... | ⑦ 2 x SQM45... + 1 x SQM48... |
| ④ 4 x SQM45... | ⑧ 3 x SQM45... + 1 x SQM48... |

CAN bus connection between transformer and actuator group



When connecting a PLL52... O2 module, the maximum permissible cable length of a network is to be reduced by 2 m.

Example: - System cable: AGG5.641 (connecting cable to the actuators)
- Actuators: 2 x SQM45...

The point of intersection of the vertical line for the AGG5.641 (1.25 mm²) and curve ① (2 x SQM45...) gives a maximum cable length of 33.4 m between the transformer and the group of actuators.

Example 1

**Installation of all components in the burner;
CAN bus cable «LMV5... →shielding last actuator» 20 m**

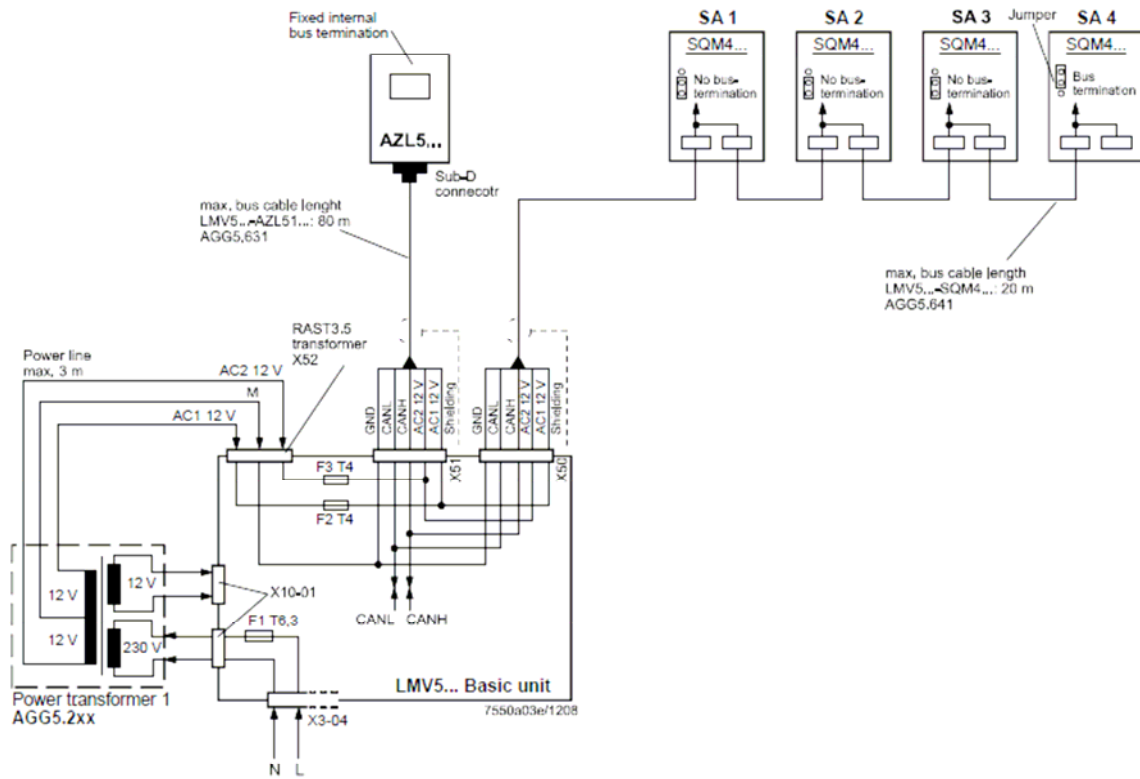

Note on example 1

Total length of CAN bus cable ≤ 100 m

Example 2

**LMV5... basic unit in the control panel, actuator on the burner;
CAN bus cable «LMV5... → SA» > 20 m**

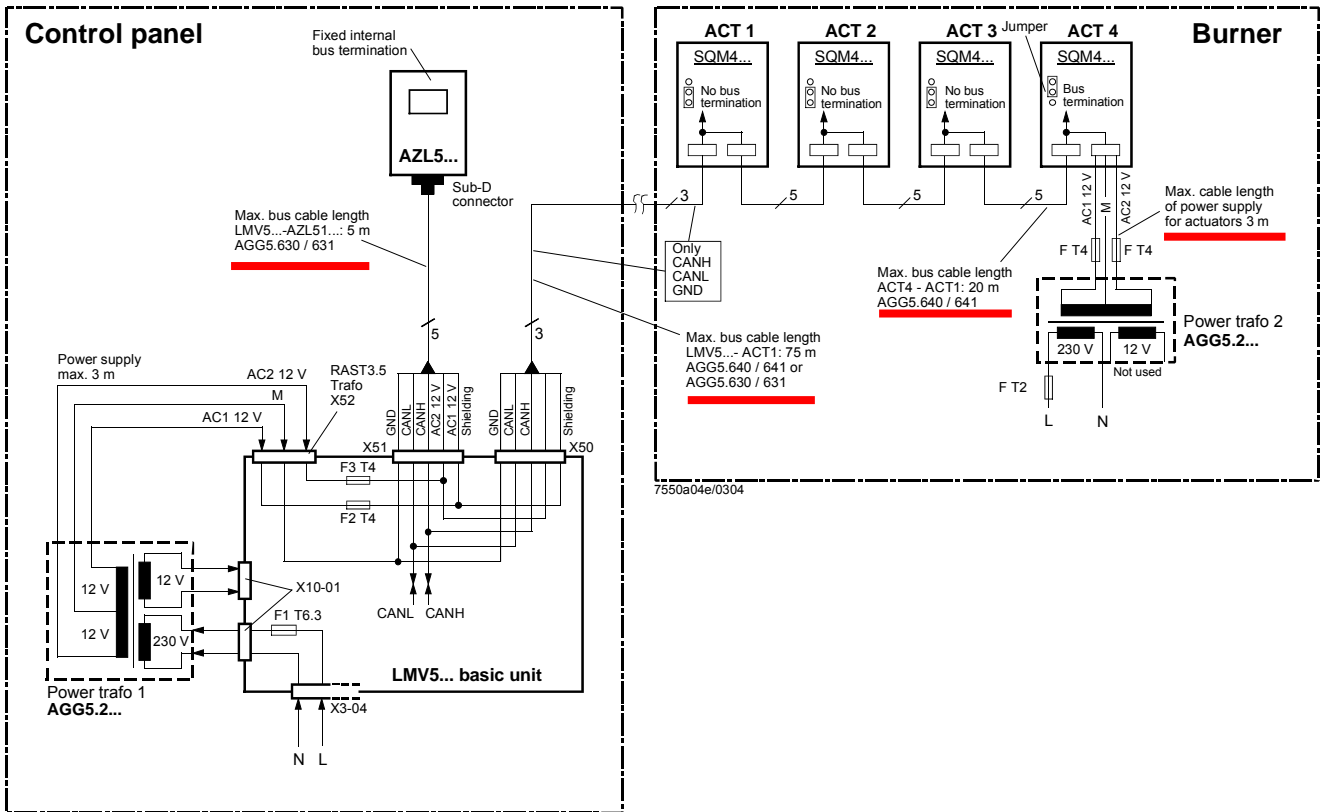

Notes on example 2

Total length of CAN bus cable ≤ 100 m

Whenever the distance between the LMV5... and the last actuator exceeds 20 m, or if more than one SQM48 is used on the burner (refer to sizing chart “Determination of maximum cable length”), a second transformer is required for powering the actuators.

In that case, transformer 1 powers the LMV5... basic unit and the AZL5... display and operating unit (**Fig. 1**). Transformer 2 powers the actuators (**Fig. 2**).



With the CAN bus cable connections from the LMV5... (**Fig. 1**) to the first actuator (**Fig. 2**), the 2 voltages AC1 and AC2 on the LMV5... side must **not** be connected and only cables CANH, CANL and M (+shielding) are to be connected to the first actuator (**Fig. 2**).

In that case, the actuators must be powered by a second transformer which to be located near the actuators.

The power from that transformer (lines AC1, AC2, M) must be fed to the actuator (ACT4 in the example above) and then connected through via bus cable AGG5.640 (cable type 1) to all the other actuators.

The fuses required for transformer 1 are accommodated in the LMV5... basic unit.



For transformer 2, these 3 fuses must be located close to the transformer (for type, refer to Basic Documentation P7550).

Example 3a

**Installation of all components in the burner;
CAN bus cable «LMV52... ↔ SA» > 20 m with 6 actuators and O2 module
PLL52...**

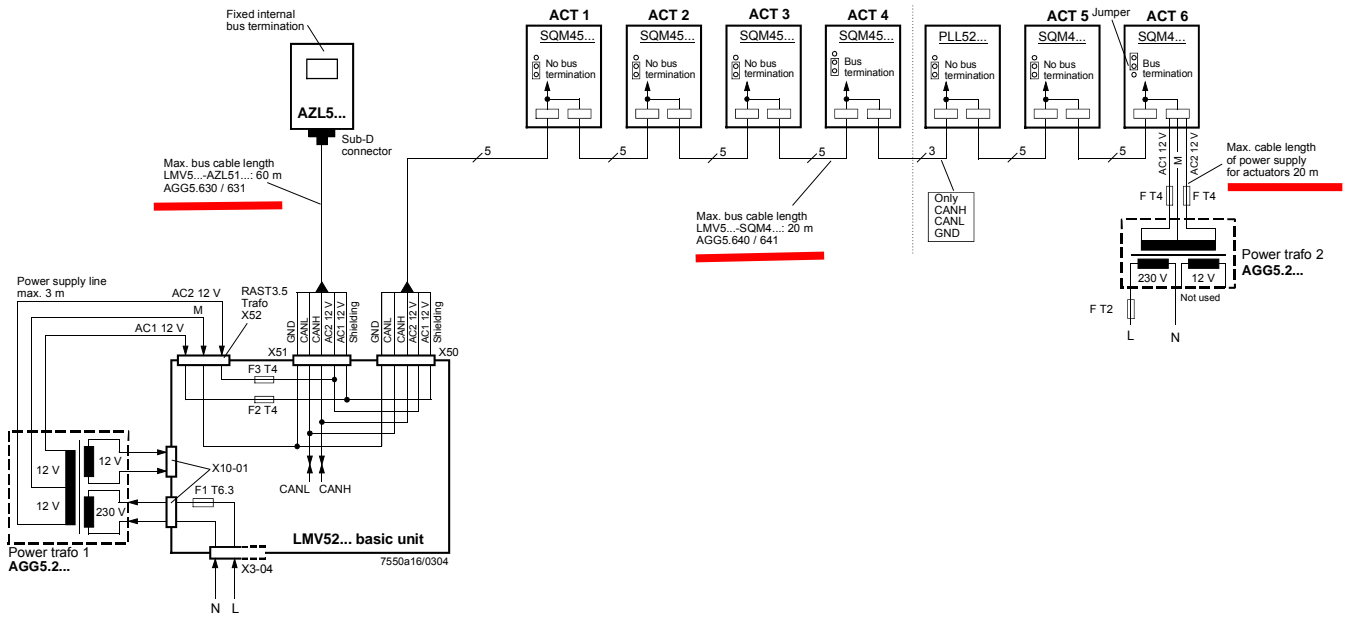

Example 3b

**Installation in the control panel, actuator on the burner;
CAN bus cable «LMV52... ↔ SA» > 25 m with 4 actuators and O2 module
PLL52...**

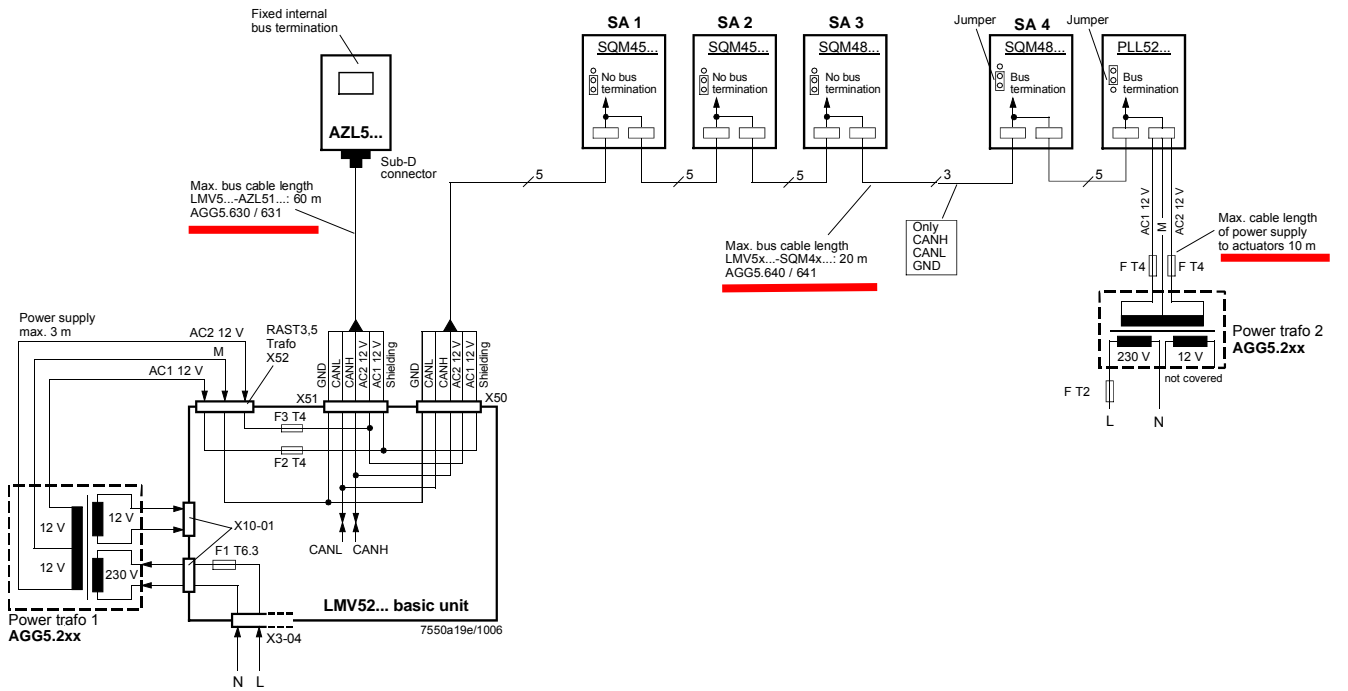

On LMV52... applications with more than 4 actuators (SQM45...), a second transformer is required for powering the extra actuators.

In that case, transformer 1 powers the LMV52... basic unit, the **AZL5...**, and the first 4 actuators.



Interrupt the connection between the components at a suitable location. On the actuator side, the 2 voltages AC1 and AC2 must **not** be connected but only lines «CANH, CANL and M» (+shield) to the O2 module and the other actuator.

In that case, the actuators (SA5, SA6) and the O2 module must be powered by a second transformer to be located near the actuators and the O2 module.

Connect the power supply line from that transformer to the O2 module PLL52... (in example 3a «SA6» / in example 3b «Auxiliary terminal») (lines AC1, AC2, M) and from there, via bus cable AGG5.640 (cable type 1), through to the second actuator (SA) and the O2 module.

The fuses required for transformer 1 are accommodated in the LMV52... basic unit.

Optionally, the supply voltage can also be delivered via a conduit box and fed into the connecting line between SA4 and PLL52...

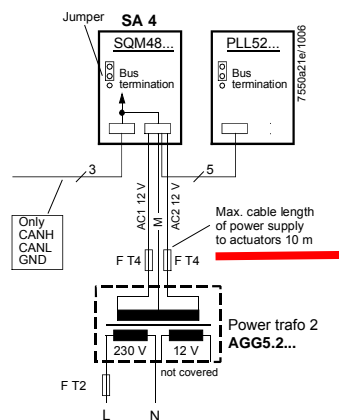

For transformer 2, the OEM must fit the 3 fuses close to the transformer.

QGO20...

Montageanleitung
 Mounting instruction
 Instruction de montage
 Monteringsanvisning
 Montage-aanwijzing

Istruzioni di montaggio
 Asennusohje
 Instrucciones de montaje
 Monteringsinstruktion
 Montasjeanvisning

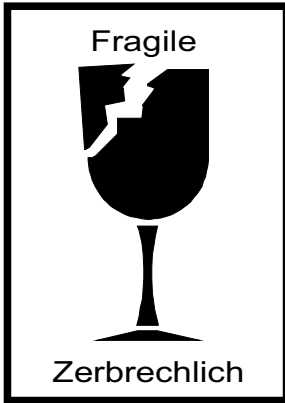

7842mb01/1200

Fühler aus Keramik - zerbrechlich
 Ceramic detector - fragile
 Sonde en céramique - fragile

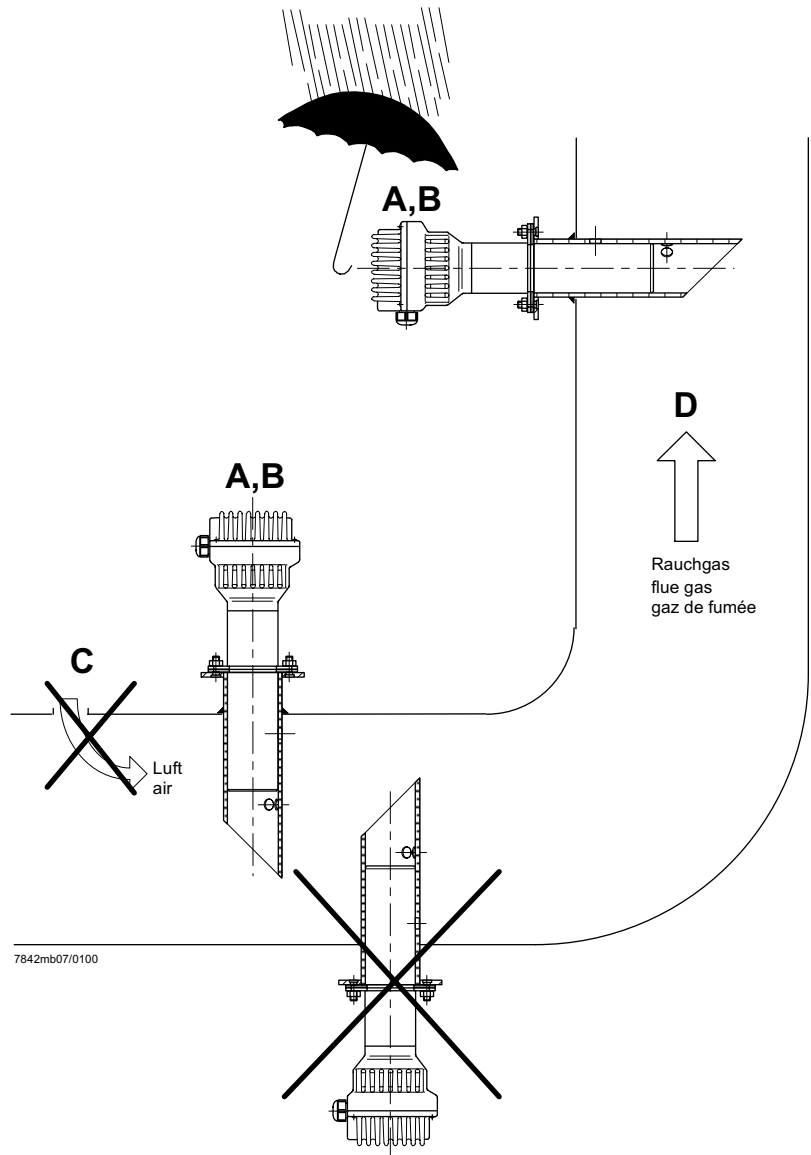

7842mb07/0100

O2-Fühler QGO20... und Rauchgassammler AGO20...

Voraussetzungen für eine korrekte messtechnische Erfassung des O2-Gehaltes der Rauchgase:

A - QGO20... **nur** mit Rauchgassammler AGO20... einsetzen

B - Einbauort des QGO20... so nahe am Brenner wie möglich, in einem Bereich ohne Turbulenzen und Inhomogenitäten. Nicht direkt im Bereich von Klappen oder Bögen montieren. Idealer Abstand: 5 x Kamindurchmesser.

C - Zwischen Brenner und Fühler darf keine Luft in die Rauchgase gelangen.

D - Strömungsgeschwindigkeit 1...10 m/s. Rauchgastemperatur am Messort $\leq 300^{\circ}\text{C}$

O2-detector type QGO20... and flue gas collector type AGO20...

Presupposition for the correct measurement of the O2 content of the flue gases:

A - Use QGO20... **only** with flue gas collector type AGO20...

B - Mounting position of the QGO as close as possible to the burner, in a homogenous area without any turbulences. Do not mount the QGO20... in the area of dampers or curves. Ideal distance: Five times the diameter of the stack.

C - No air must be allowed to join the flue gases on their way from the burner to the detector.

D - Flow velocity 1...10 m/s. Flue gas temperature at the measuring position $\leq 300^{\circ}\text{C}$

Sonde O2 QGO20... et collecteur des gaz de fumée AGO20...

Conditions requises pour une détection correcte de la teneur en O2 des gaz de fumée:

A - Utiliser le QGO20... **exclusivement** avec le collecteur des gaz de fumée AGO20...

B - Lieu de montage du QGO20... le plus près possible du brûleur, dans un domaine homogène sans turbulences. Ne pas le monter dans le domaine des clapets ou dans les courbes. Distance idéale: Cinq fois le diamètre de la cheminée.

C - Entre le brûleur et la sonde, il ne doit pas pénétrer d'air dans les gaz de fumée.

D - Vitesse d'écoulement 1...10 m/s. Température des gaz fumée au lieu de la mesure $\leq 300^{\circ}\text{C}$

Anschluss-Schema

6-adriges abgeschirmtes Kabel. Adern möglichst paarweise verdreht. Abschirmung an Klemme GND des RPO... . Abschirmung nicht mit Schutzleiter oder M verbinden!

Anschlusskabel z.B.:

LifYCY 6 x 2 x 0,20 / 22 oder
LiYCY 6 x 2 x 0,20

B1 (+) Signal O₂-Messzelle
M (-) Masse für B1, B2

B2 (+) Thermoelement-Spannung
M (-)

U3 (+) Signal Temperaturkompensations-
element
G2 (-) Speisung Temperaturkompensations-
element

GND Masse für Anschirmung

3 x 1,5 mm²:

Q4 Fühlerheizung (AC 230 V)
Q5 Fühlerheizung (AC 230 V)

⏏ Erde*



Vorsicht bei den Anschlüssen U3 und G2!
Ein Fehlverdrahten der Anschlüsse führt zu einem
Ausfall des Kompensationselementes.

* Am RPO... steht nur 1 Erdleiterklemme zur
Verfügung. Beide Erdleiter müssen auf **eine**
Klemme geführt werden.

Wiring diagram

Shielded 6-core cable. Wires should be twisted in
pairs. Screen must be connected to terminal GND
of the RPO... . Do not connect the shielding to the
protective earth or M!

Connecting cable e.g.:

LifYCY 6 x 2 x 0,20 / 22 or
LiYCY 6 x 2 x 0,20

B1 (+) Signal from O₂-measuring cell
M (-) Ground for B1, B2

B2 (+) Thermocouple voltage
M (-)

U3 (+) Signal from temperatue
compensation element
G2 (-) Power supply for temperature
compensation element

GND Ground for screening

3 x 1,5 mm²:

Q4 QGO... detector heating (AC 230 V)
Q5 QGO... detector heating (AC 230 V)

⏏ Earth*



Caution when connecting U3 and G2!
Faulty wiring leads to failure of the compensation
element.

* At the RPO... there is only 1 earth terminal
available. Both earth wires must be connected
to **the same** earth terminal.

Schéma de raccordement

Câble blindé à 6 brins. Brins torsadés si possible par
paires. Blindage sur la borne GND du RPO... . Ne pas
connecter le blindage avec le conducteur de protection
ou M!

Câble de raccordement p.ex.:

LifYCY 6 x 2 x 0,20 / 22 ou
LiYCY 6 x 2 x 0,20

B1 (+) Signal de la cellule de mesure d'O₂
M (-) Masse pour B1, B2

B2 (+) Tension de thermocouple
M (-)

U3 (+) Signal de l'élément de cpmensation de
température
G2 (-) Alimentation de l'élément de
compensation de température

GND Masse du blindage

3 x 1,5 mm²:

Q4 Chauffage de sonde QGO... (AC 230 V)
Q5 Chauffage de sonde QGO... (AC 230 V)

⏏ Terre*



Prière de faire attention lors des raccordements U3
et G2. Une erreur de câblage des fils de raccor-
dement conduit à une destruction de l'élément de
compensation.

* Le RPO... ne dispose que d'une seule borne de
mise à la terre. Les deux fils de mise à la terre
doivent être connectés sur **la même** borne.

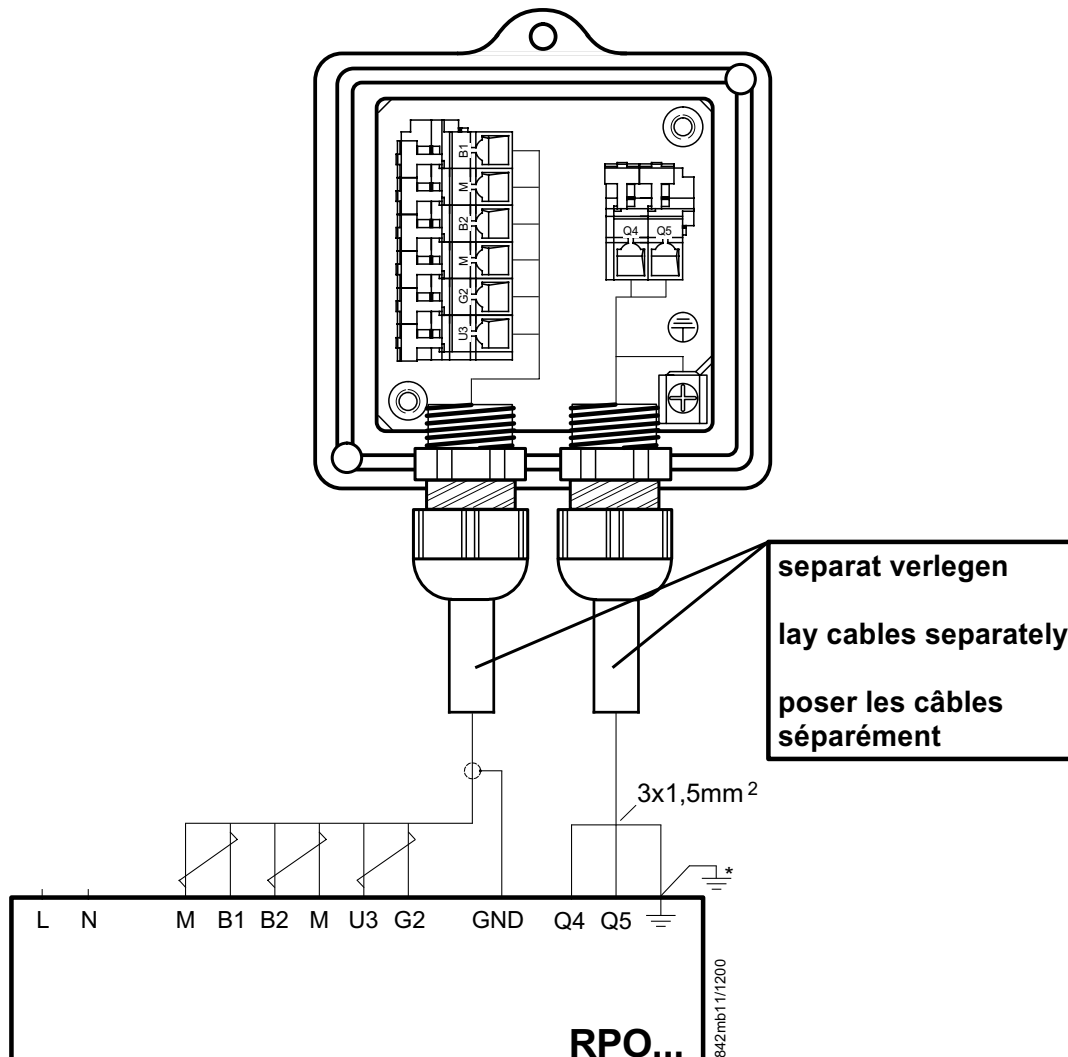

Hinweise für Installation und Inbetriebnahme

- Distanz zwischen Wand des Rauchgaskanals und Rauchgasaustritt (B) des AGO20... min. 10 mm
- Die Kaminisolierung darf nicht über den Anschlussflansch hinausragen und dadurch den Fühlerkopf isolieren (therm. Überlastung). Der Fühlerkopf muss frei bleiben! Strahlungswärme vermeiden; z.B. durch Wärmeleitbleche
- Bei der ersten Inbetriebnahme ist das Mess-System ca. 2 Stunden vor Gebrauch einzuschalten. Bei kurzen Abschaltungen der Anlage (1-2 Wochen) ist es empfehlenswert, das Mess-System (QGO... und RPO) nicht auszuschalten.
- Während des Aufheizvorganges kann der Fühler falsch messen.



- QGO20... nie im kalten Zustand bei laufendem Brenner im Kamin einsetzen.
- Nach Fühlertausch, Ansteuerung der Fühlerheizung überprüfen.
- Spannung an Q4 - Q5 muss im 2 s Takt pulsieren.
- **Sofort ausschalten** falls Spannung nicht pulsieret
 ↳ RPO austauschen

Commissioning and Installation Guide

- The distance between the wall of the flue gas duct and the flue gas outlet (B) of the AGO20... must be a minimum of 10 mm
- The insulation of the chimney must not project beyond the connecting flange, thus insulating the head of the sensor (thermal overload). The head of the sensor must remain uncovered! Avoid heat due to radiation, e.g. through thermal conductive plates
- When starting up the plant for the first time, the measuring system should be switched on approx. 2 hours prior to usage. If the plant is switched off for short periods of the time (1 to 2 weeks), it is recommended to leave the measuring system (QGO... and RPO) switched on.
- During the heating up phase, the detector could deliver an incorrect signal.



- Never use a cold QGO20... in the flueway while burner is operating.
- After changing the sensor, check the proper functioning of the sensor's heating element
- Voltage at Q4 - Q5 must pulsate at 2-s intervals
- If voltage does not pulsate, **switch equipment off immediately**
 ↳ replace RPO

Instructions de mise en service et installation

- La distance entre la paroi de la conduite de gaz et la sortie des gaz de fumée (B) du AGO20... doit être d'au moins 10 mm.
- L'isolation de la cheminée ne doit pas dépasser la bride de raccordement, c'est-à-dire couvrir la tête de la sonde (surcharge thermique). La tête de la sonde ne doit pas être couverte! Éviter la chaleur de rayonnement, p.ex. par tôles thermoconductrices
- Lors de la première mise en service, le dispositif de mesure doit être raccordé environ 2 heures avant l'utilisation. En cas de courtes interruptions de l'installation (1-2 semaines), il est recommandé de ne pas déclencher le dispositif de mesure (QGO... et RPO).
- Pendant l'opération d'échauffement, il est possible que la sonde ne mesure pas correctement.



- Ne jamais introduire le QGO20... à l'état froid ou le laisser introduit dans la cheminée quand le brûleur est en marche.
- Lors d'un changement de sonde, vérifier le signal de chauffage de celle-ci.
- Les tensions aux bornes Q4 - Q5 doivent commuter toutes les 2 s.
- **Déconnecter immédiatement** en cas de non-commutation des tensions
 ↳ Echanger le RPO

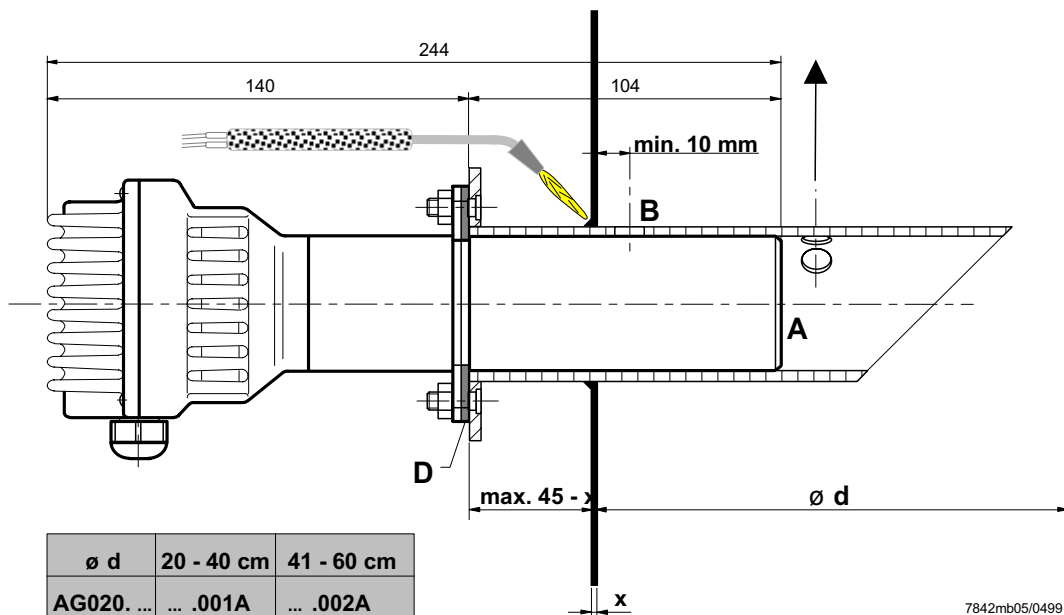

7842mb05/0499

Kerben beachten!
Observe notches!
Attention aux entailles!

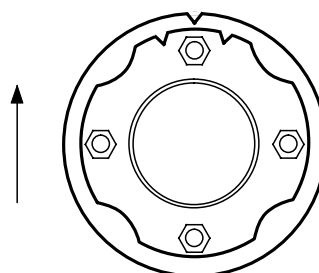

7842mb06/0499

Legende:
 Strömungsrichtung
 Direction of flow of flue gases
 Direction du courant des gaz de fumée

Maßbilder / Dimensions / Encombrements

QGO20...

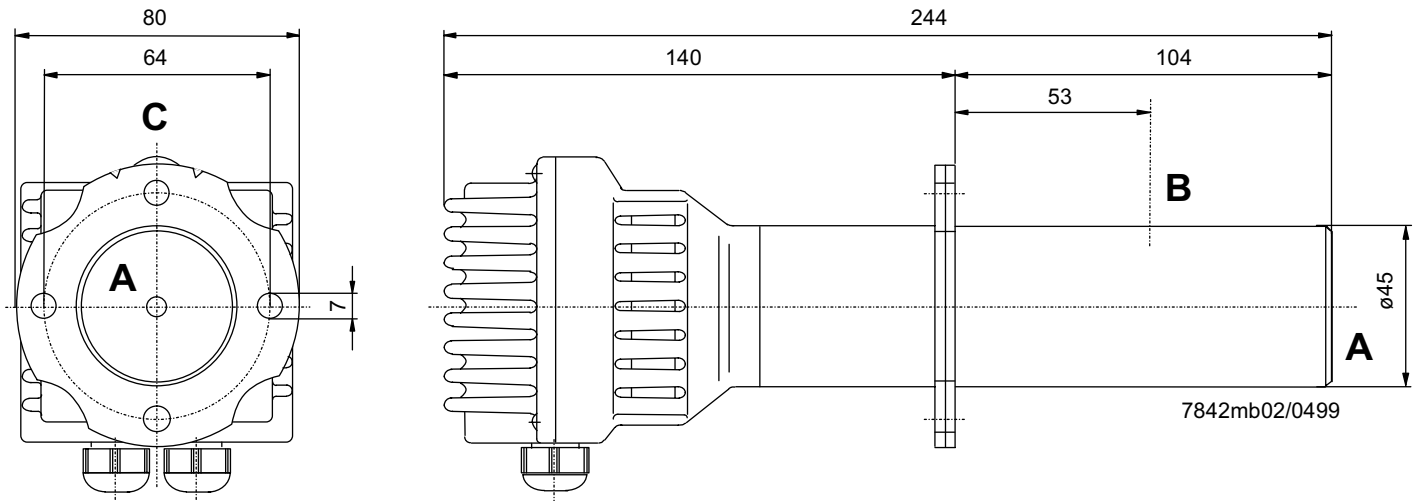

AGO20...

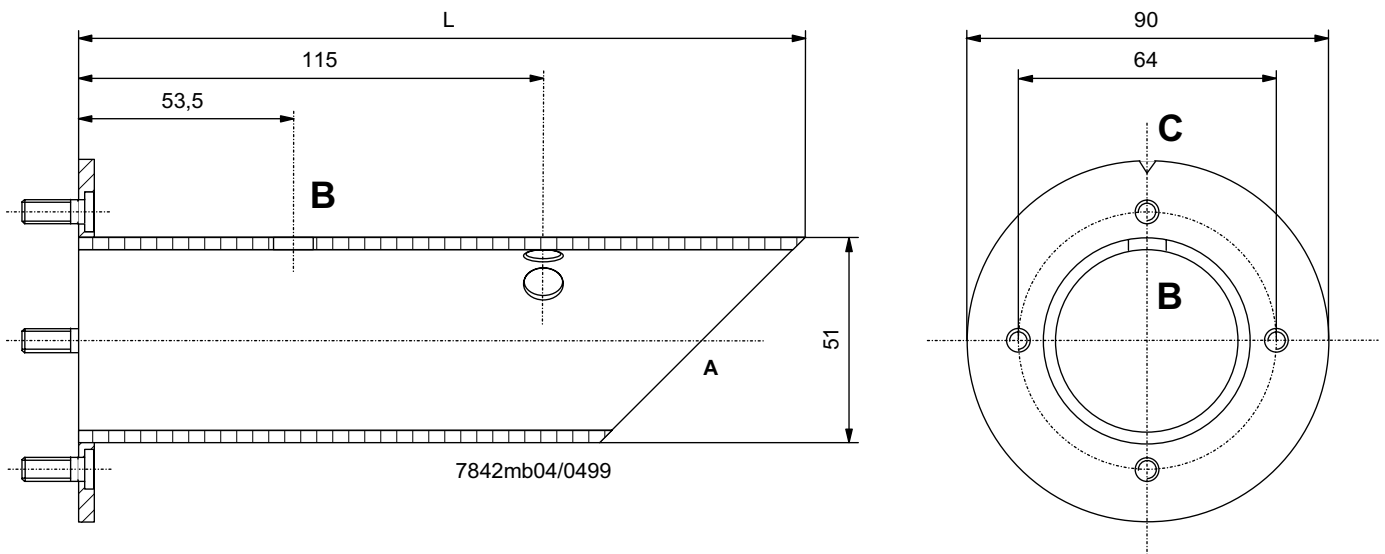

L = 180 mm für AGO20.001A
L = 260 mm für AGO20.002A

A = Rauchgaseintritt
B = Rauchgasaustritt
C = Kerbe
D = Flachdichtung (beiliegend)

L = 180 mm for AGO20.001A
L = 260 mm for AGO20.002A

A = Flue gas inlet
B = Flue gas outlet
C = Notch
D = Flat seal (enclosed)

L = 180 mm pour AGO20.001A
L = 260 mm pour AGO20.002A

A = Entrée du gaz de fumée
B = Sortie de gaz de fumée
C = Entaille
D = Joint d'étanchéité plat (inclus)

Technical Data PLL52...

LMV52... basic unit

Refer to chapter *Technical Data!*

PLL52...

Mains voltage «X89-01»	AC 120 V -15 % / +10 %	AC 230 V -15 % / +10 %
Safety class	I with parts according to II as per DIN EN 60730-1	
Mains frequency	50 / 60 Hz ±6 %	
Power consumption	Ca. 4 VA	Ca. 4 VA
Degree of protection	IP54, housing closed	
Transformer AGG5.210		
- Primary side	AC 120 V	
- Secondary side	AC 12 V (3x)	
Transformer AGG5.220		
- Primary side	AC 230 V	
- Secondary side	AC 12 V (3x)	

Environmental conditions

Storage	DIN EN 60 721-3-1
Climatic conditions	class 1K3
Mechanical conditions	class 1M2
Temperature range	-20...+60 °C
Humidity	< 95 % r.h.
Transport	DIN EN 60 721-3-2
Climatic conditions	class 2K2
Mechanical conditions	class 2M2
Temperature range	-30...+70 °C
Humidity	< 95 % r.h.
Operation	DIN EN 60 721-3-3
Climatic conditions	class 3K5
Mechanical conditions	class 3M2
Temperature range	-20...+60 °C
Humidity	< 95 % r.h.



Condensation, formation of ice or ingress of water are not permitted!

Terminal ratings, cable lengths and cross-sectional areas

LMV52... basic unit

Refer to chapter «Technical Data / LMV5... and AZL5...!»

PLL52...

Cable lengths / cross-sectional areas	
Electrical connection «X89»	Screw terminals up to max. 2.5 mm ²
Cable lengths	≤10 m to QGO20...
Cross-sectional areas	Refer to description of QGO20... Twisted pairs

Analog inputs:

Fresh air temperature detector	Pt1000 / LG-Ni1000
Flue gas temperature detector	Pt1000 / LG-Ni1000
QGO20...	Refer to Data Sheet N7842
Interface	Communication bus for LMV52...

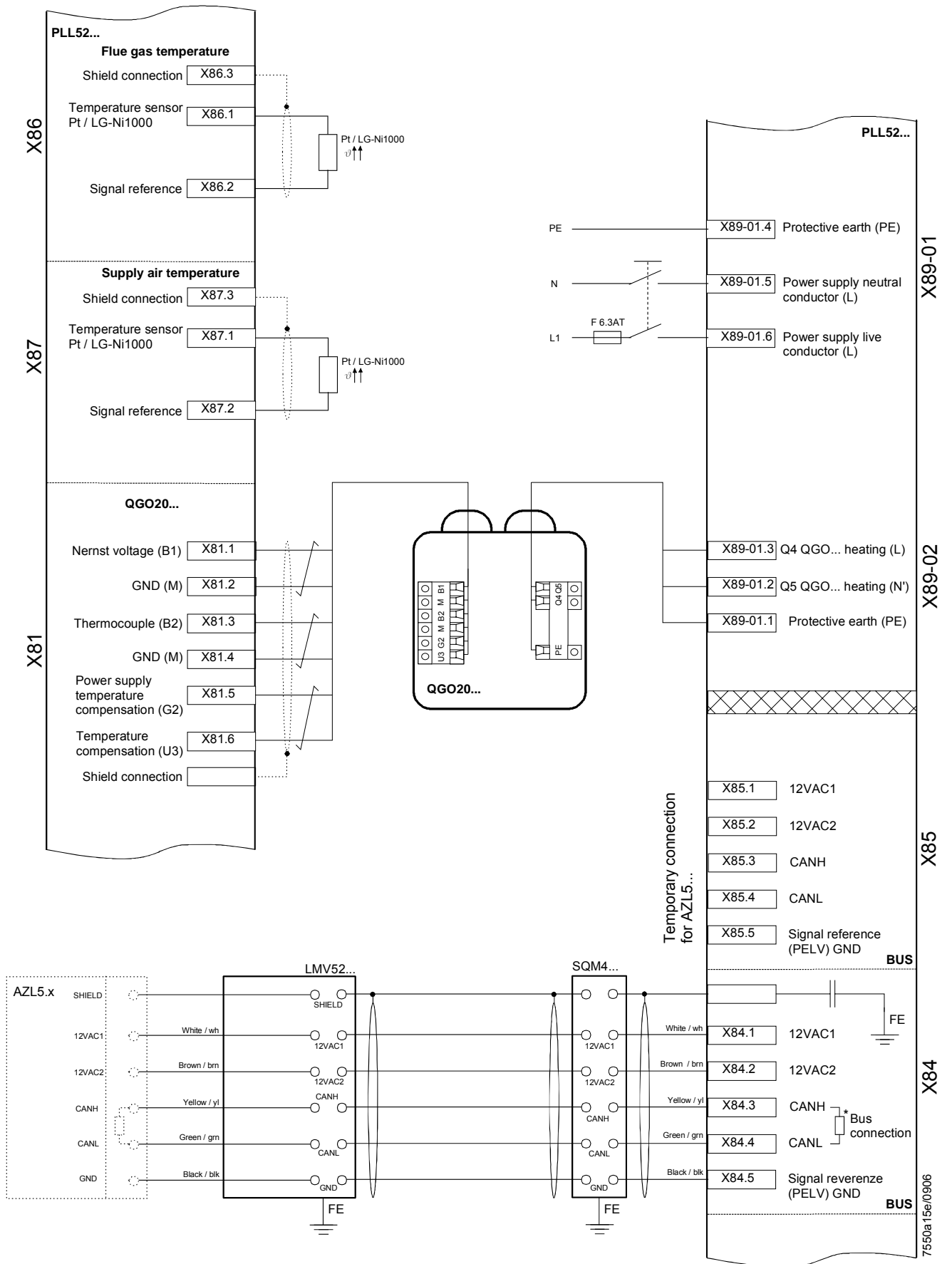

7550a15e/0906

KOSTAL INVERTER

Connection and programming
for electronically controlled burners with

**LMV2x/3x, LMV5x, ETAMATIC
and INVERTER regulation**

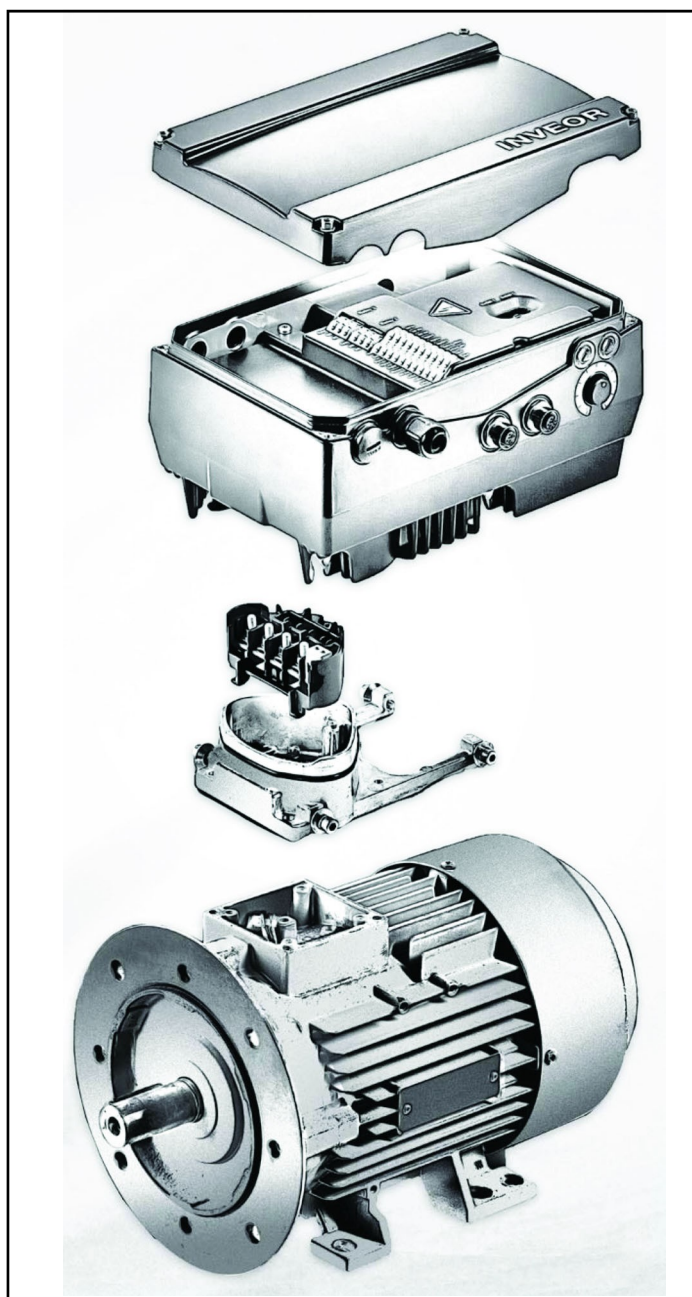

**Service Manual
TECHNICAL
INSTRUCTIONS**

Table of contents:

INVERTER identification, 3

User interface communication (on request), 4

Electrical connections, 5

Motor connection variants for INVERTERS sizes A, B and C, 5

Motor connection variants for INVERTER size D, 6

Connection of INVERTER signals and commands, 7

Electrical connections and parameter configuration, 7

0-10V / 4-20mA analogue input configuration, 8

Configuration of control contact / INVERTER starting and stopping, 9

Configuration of INVERTER start / stop parameters and operating mode, 10

Motor data, 11

Output signal variant for reading motor rpm (optional), 12

Brake chopper connections, 14

Burner terminal with INVERTER interface, 16

IDENTIFICAZIONE INVERTER

INVEOR M_x IV_{xx} PW_{xx} LP_{xx} AP_{xx} GH_{xx} DK_{xx} CO_{xx} 1

1 2 3 4 5 6 7 8 9 10

Key		Key	
1	Drive controller series: INVEOR	6	Application circuit board: AP12 - Standard AP13 - CANopen
2	Installation location/size: motor-integrated - M, size: α , A, B, C, D	7	Control: DK01 - Standard (without membrane keypad) DK04 - With membrane keypad
3	Input voltage : IV02 - 230 V	8	Housing : GH10 - standard heat sink (black painted)
4	Recommended motor rating : kW: 0.55; 0.75; 1.1; 1.5; 2.2; 3.0; 4.0; 5.5; 7.5; 11.0; 15.0; 18.5; 22.0	9	Firmware version : CO00 - Standard CO01 - Specific
5	Printed circuit boards : LP01 / LP03 - Standard (without brake chopper); LP02 / LP04 - Standard (with brake chopper);	10	Equipment generation: 1 - current version

The **LMV5x** device controls fan motor rpm via a sensor and commands it via the inverter with a **4÷20mA** signal.

The **LMV3x/LMV2x** device controls fan motor rpm via a sensor and commands it via the inverter with a **0÷10V** signal.

Generally, the inverter curve goes from 50% to 100% of motor rpm. As well as improving burner regulation, this allows for a saving in terms of fan motor consumption.

INVEOR M INVERTER SIZES

**TAGLIE
INVERTER INVEOR M...**



α



A



B



C



D



User interface

COMMUNICATION (on request)

The drive controller can be put in operation in the following ways:

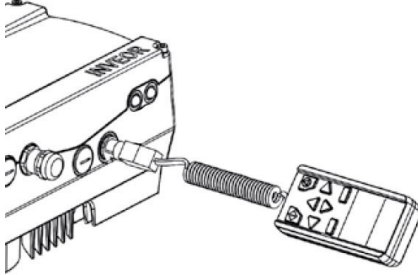

Attention: Contact the manufacturer to order the most suitable device.

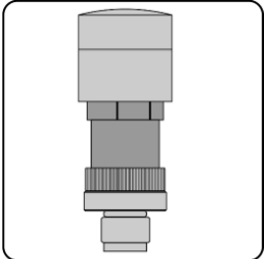
USB adaptor for PC	
Via the INVERTER PC software	
	
INVEOR MMI remote display:	
<p>INVEOR MMI is a portable display on which all inverter parameters can be viewed and changed. Manual available on the KOSTAL website.</p>	
Bluetooth connection:	
<p>Using the Bluetooth adaptor you can connect via app from any device. Download the app for Android / iOS from the Google Play Store / App Store.</p>	
<p>The Bluetooth adaptor is required to create a Bluetooth connection with the inverter. To view and change the inverter parameters, use an external interface device – tablet or mobile phone. Download the app for Android / iOS from the Google Play Store / App Store.</p>	

ELECTRICAL CONNECTIONS

Motor connection variants for INVERTERS sizes A, B and C

Star or delta connection for speed controller integrated on the motor

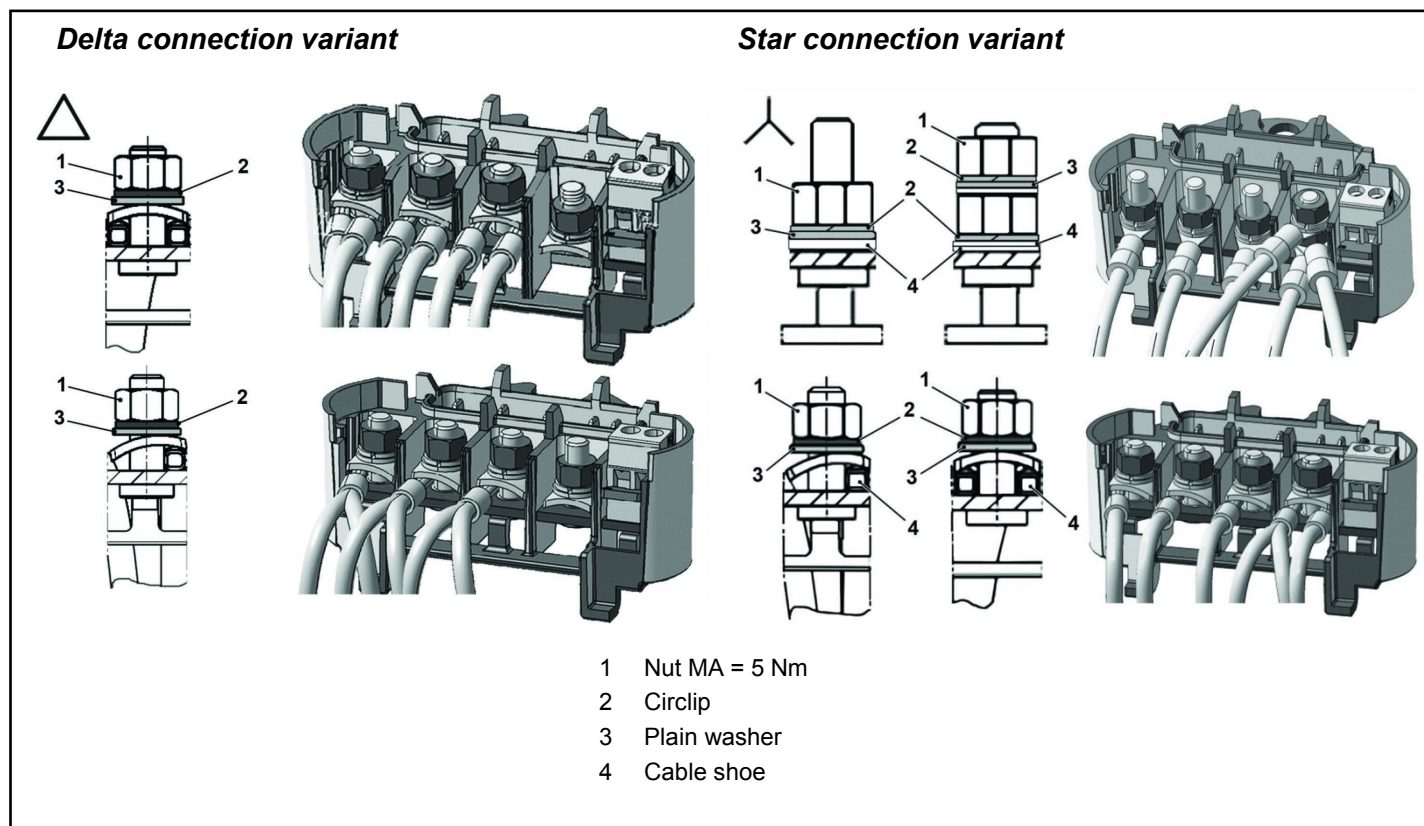
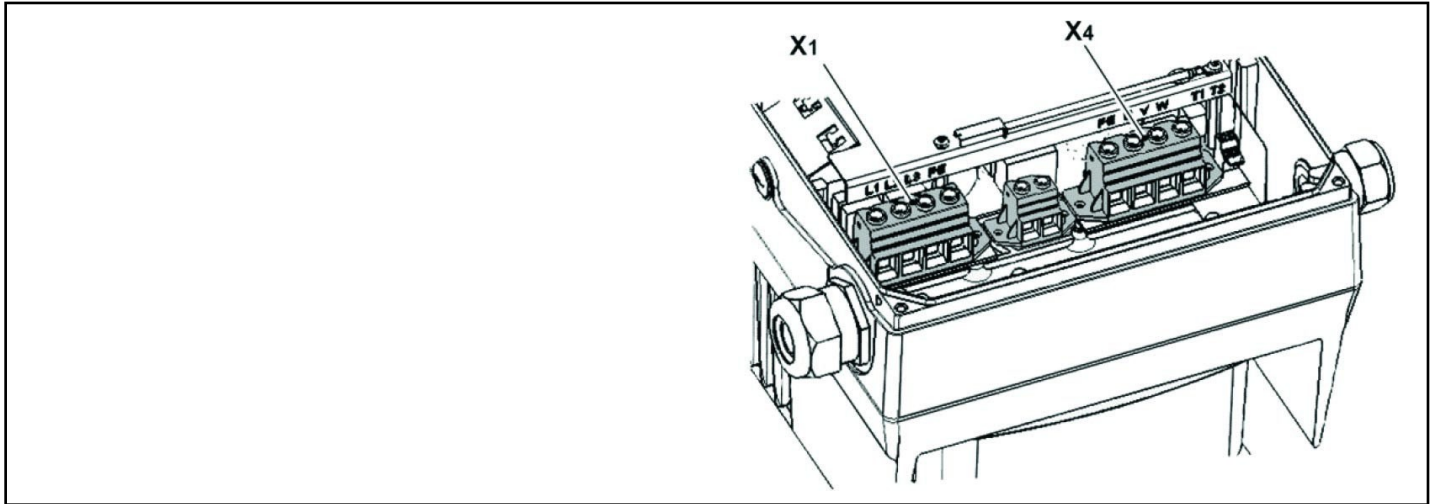

Fig. 1

Motor connection variants for INVERTER size D



X1 terminal no.	Designation	Assignment
1	L1	Mains phase 1
2	L2	Mains phase 2
3	L3	Mains phase 3
4	PE	Protective conductor

Tab. 1 - X1 terminal assignment - 3 x 400 VAC

X4 terminal no.	Designation	Assignment
1	PE	Protective conductor
2	U	Mains phase 1
3	V	Mains phase 2
4	W	Mains phase 3

Tab. 2 - X1 terminal assignment - 3 x 400 VAC

Fig. 2 – Assembly sequence: Connection box – adapter plate size D

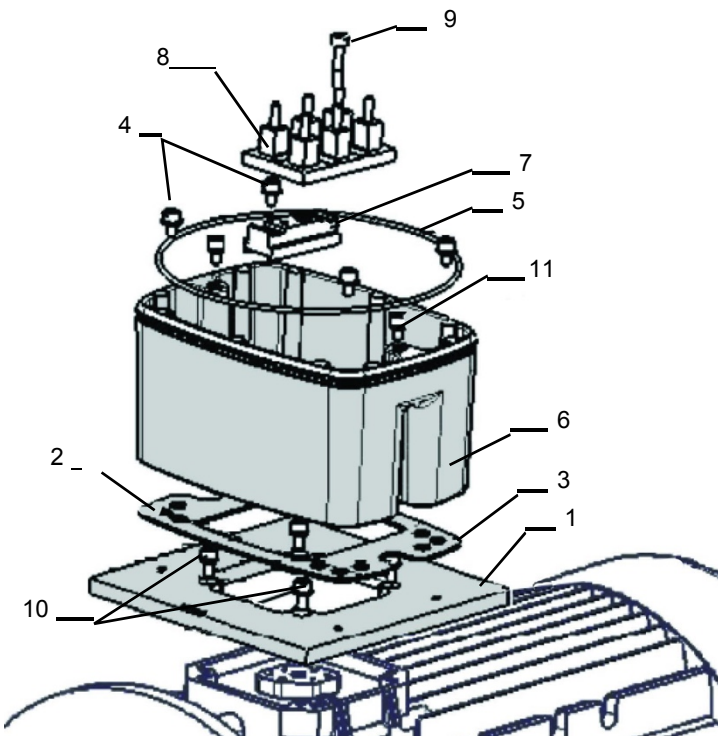

Key:

- 1 Adapter plate option (variant)
- 2 Holes depending on motor
- 3 Seal
- 4 Retaining bolts with spring elements
- 5 O-ring seal
- 6 INVEOR / adapter plate support
- 7 Terminal heightening option
- 8 Original terminal (not included)
- 9 Extended screw option (for pos.7)
- 10 Retaining bolts with spring elements option
- 11 INVEOR/support retaining bolts

Connection of INVERTER signals and commands

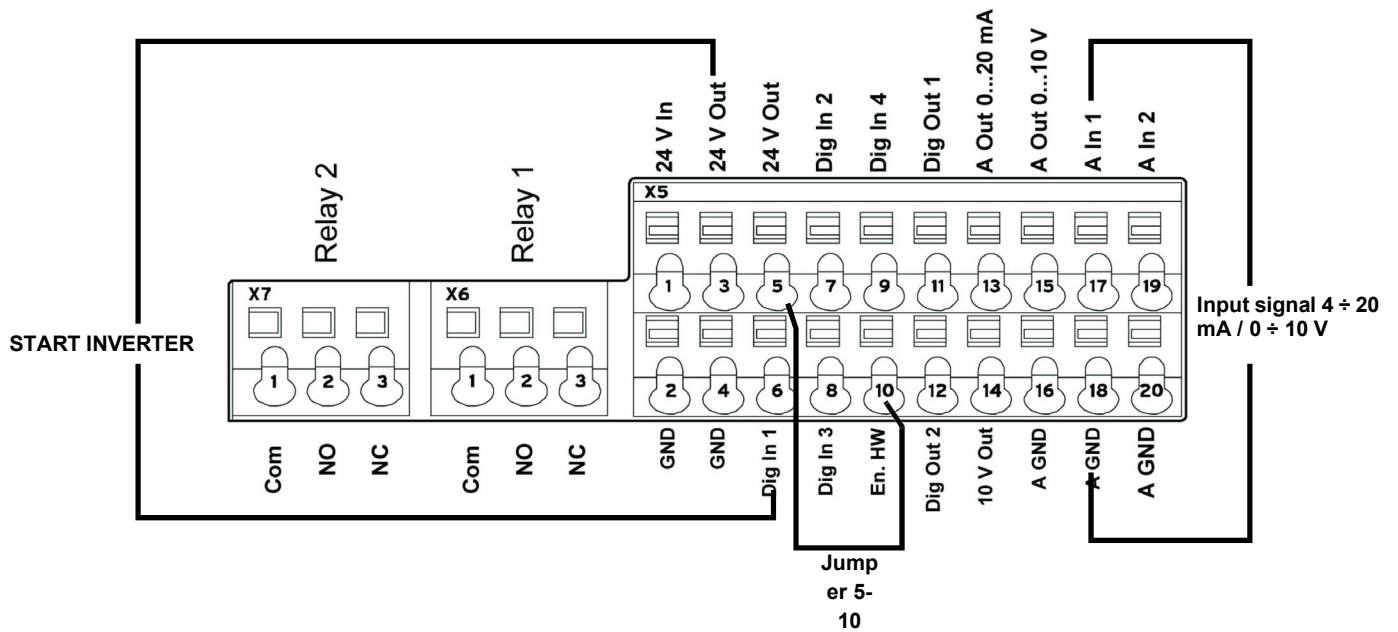

Electrical connections and parameter configuration

There are 2 relays on the INVERTER. Connecting terminals X7-1-2-3 and X6-1-2-3 are used for:

LMV2/3x: Relay 1 is used as a safety contact on the safety loop series of the equipment. Relay 2 is used as a fault indicator on the burner panel front.

LMV5x / ETAMATIC: Relay 1 is used as a contact for control of fan motor start. Relay 2 is used as a fault indicator of the INVERTER to the LMV5x / ETAMATIC equipment.

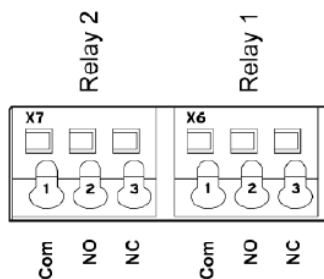

Parameter		
1.181	Automatic reset function	Automatic reset of faults. The INVERTER resets the fault after the set time. Set value = 30 seconds
1.182	Automatic reset numbers	With the reset function the maximum number of automatic resets can be limited. Set value = 0 (maximum number of automatic resets)
4.190	Relay 1 functions	Select the operating mode of relay 1. Set value = LMV2x/3x..= 11 (NC inverted error) Set value = LMV5x / ETAMATIC = 19 (motor is in NO function)
4.210	Relay 2 functions	Select the operating mode of relay 2. Set value = LMV2x/3x..= 11 (NC inverted error) Set value = LMV5x / ETAMATIC = 11 (NC inverted error)
4.210	V O operation	Set value = 10 (NO error)

0-10V / 4-20mA analogue input configuration

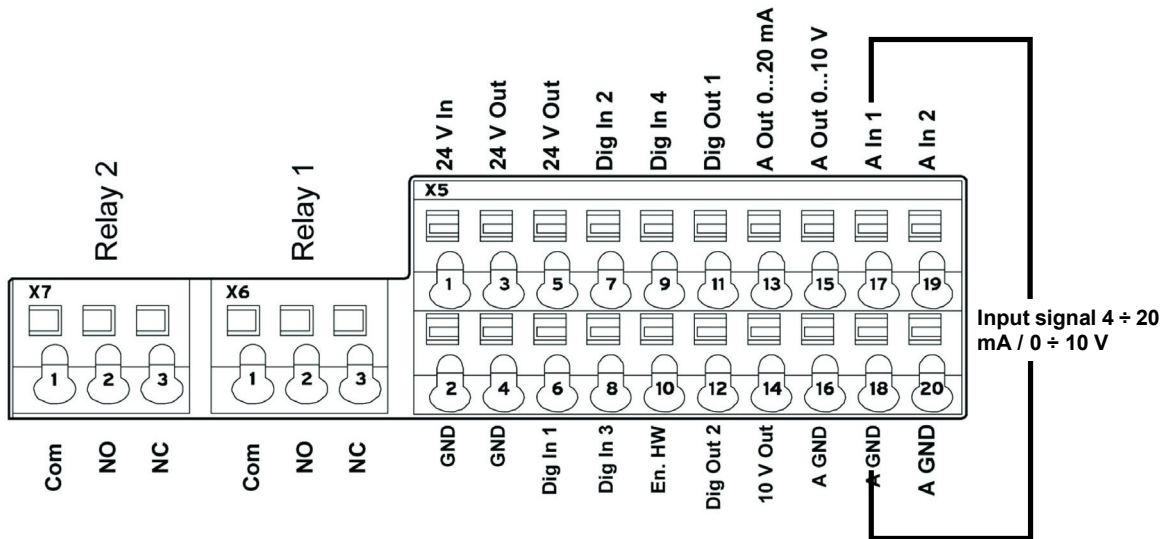

Input AI1 can be configured as voltage or current input. It is configured as 4-20mA input current for LMV5-Etamatic, and 0-10V input voltage for LMV2x/3x.

4.020	Input type AI1	Specifies the input type, whether voltage or current. 1= Voltage input 0-10V (LMV2x/3x) 2= Current input 0/4-20mA (LMV5 ETAMATIC)
4.021	AI1 Standard low	Specifies the minimum value of the analogue input as a percentage of the range. E.g.: 0... 10 V or 0...20 mA = 0 %...100 % 2... 10 V or 4...20 mA = 20 %...100 % Set value = 20% for LMV2x/3x, LMV5x, ETAMATIC
4.022	AI1 Standard high	Specifies the maximum value of the analogue input as a percentage of the range at 10V or 20mA. Set value = 100%
4.023	AI1 Response time	Specifies the deadband on the input signal. Set value = 1%
4.024	AI1 Filter time	An input change is taken into consideration after this time. If it is too short, a wire break error may appear if the 4-20 mA signal goes to 0 for a short time. Set value = 4 seconds
4.030	AI1 Input function	Specifies whether the input is 0 = analogue / 1 = digital input. Set value = 0 analogue
4.033	AI1 Measure unit, input 1	Specifies the unit of measurement of input 1. Set value = 0 (%)
4.034	AI1 Lower limit	Specifies the lower limit of input 1. Set value = 0 (%)
4.035	AI1 Upper limit	Specifies the upper limit of input 1. Set value = 100 (%)
4.036	AI1 Wire break time, 5s	Specifies the time after which the fault appears if input AI1 is interrupted (wire break). Set value = 5 seconds
4.037	AI1 Inversion	Inverts the signal of input 1. Set value = 0 (disabled)

Configuration of control contact / INVERTER starting and stopping

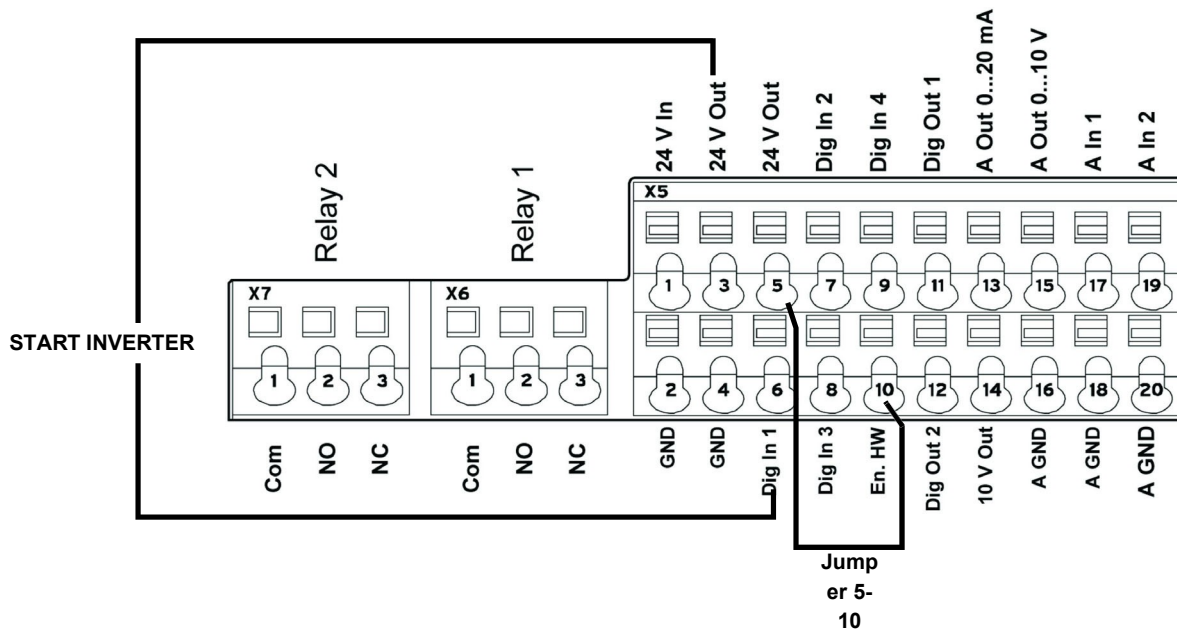

Terminal	
X5-3 (24V Out)... X5-6 (Digit In1)..	Bringing 24V to terminal X5-6 enables INVERTER operation and the contact that switches it on/off. On LMV2/3x X5-3 (24V Out) also powers the motor speed encoder.
X5-5 (24V Out) connected with X5-10 (En.HW)...	Required to enable braking ramp xxxx

Configuration of INVERTER start / stop parameters and operating mode

Parameter		
1.020	Min. frequency (Hz)	Minimum input frequency in Hz. Set value = 0 Hz (LMV2x-3x / LMV5x) Set value = > 35 Hz (ETAMATIC)
1.021	Max. frequency (Hz)	Maximum input frequency in Hz. Set value = 51,5 Hz (LMV2x-3x / LMV5x) Set value = 50 Hz (ETAMATIC)
1.050	Ramp 1 Braking time 1	Braking time at switch-off to reach the speed of 0 Hz after the start/stop contact has opened (not used). Set value = 10 seconds
1.051	Ramp 1 Acceleration time 1	Acceleration time 1 is the time necessary for the drive controller to accelerate from 0 Hz to maximum frequency (not used). Set value = 10 seconds
1.052	Ramp 2 Braking time 2	Braking time at switch-off to reach the speed of 0 Hz after the start/stop contact has opened. Set value = 10 seconds
1.053	Ramp 2 Acceleration time 2	Acceleration time 2 is the time necessary for the drive controller to accelerate from 0 Hz to maximum frequency. Set value = 10 seconds
1.054	Selects ramp used	Digital input 1 (dig In1 / X5-6) selects the ramp used. Set value = 1 (parameters 1.052 and 1.053)
1.088	Quick stop	Not used but set. Set value = 10 seconds
1.100	Operating mode	Frequency control mode: specifies the operating mode of the INVERTER. In our case it is always frequency control (0). Set value = 0
1.130	Reference set point	Determines the source from which the reference value is read. In our case it is always analogue input AI1. Set value = 1 (analogue input 1)
1.131	Enabling software	Depending on the change made, the motor may start immediately. Selection of the source for enabling control. Set value = 0
1.132	Start-up protection	Selection of behaviour in response to enabling software. Set value = 1 (Start only with rising edge at input of control enable)
1.150	Motor rotation direction	Do not change this parameter. To invert the direction of rotation, invert 2 of the 3 INVERTER / MOTOR cabling wires, so that the INVERTERS always have the same setting. Set value = 1 forwards only / clockwise rotation (no changes to direction of rotation are possible)

Motor data

The motor data depend on the type of motor used. Refer to the data shown on the motor nameplate. Follow the steps below:

- Enter the motor data;
- Activate the motor recognition function;
- If the operation ends successfully, enter the remaining parameters.

During the recognition phase, the INVERTER measures some parameters and changes some settings.

N.B.: At each start-up of the recognition programme, recheck all the parameters in this manual.

Parameter		
33.001	Motor type	Selection of motor type. Set value = 1 (asynchronous motor)
33.010	Motor I ² t factor	Not used. Only for encoders. Set value = 100%
33.011	I ² t time	Not used. Only for encoders Set value = 30 seconds
33.015	R optimisation	If necessary, this parameter can be used to optimise the start-up behaviour. Not used Set value = 100%
33.016	Motor phase control	The "Motor connection interrupted" error monitoring (error 45) can be enabled/disabled with this parameter. Set value = 1 (enabled control)
33.031	Motor current	Maximum motor current. Set value = motor nameplate current value in amps
33.032	Motor rating	Motor shaft rating. Set value = motor nameplate rating value in watts
33.034	Motor rpm	Motor rpm. Set value = motor nameplate speed in rpm
33.035	Motor frequency	Nominal motor frequency. Set value = motor nameplate frequency in Hz
33.050	Stator resistance	Recognised by INVERTER. Set value = automatically detected, value in Ohm
33.105	Leakage inductance	Recognised by INVERTER. Set value = automatically detected, value in henry
33.110	Motor voltage	Nominal motor voltage. Set value = 400V
33.111	Motor cos phi	Data on motor nameplate. Set value = 0,xx
33.138	Holding current time	Needed to stop the motor!! After braking it is held at continuous current for a specified time interval. Ensure that there is no overheating in this phase. Recommended time: max 5 s. Set value = 0 seconds

Activate the “Motor identification” function and follow the instructions proposed by the INVERTER, then change the parameters described below. The image shows the software screen on the PC.

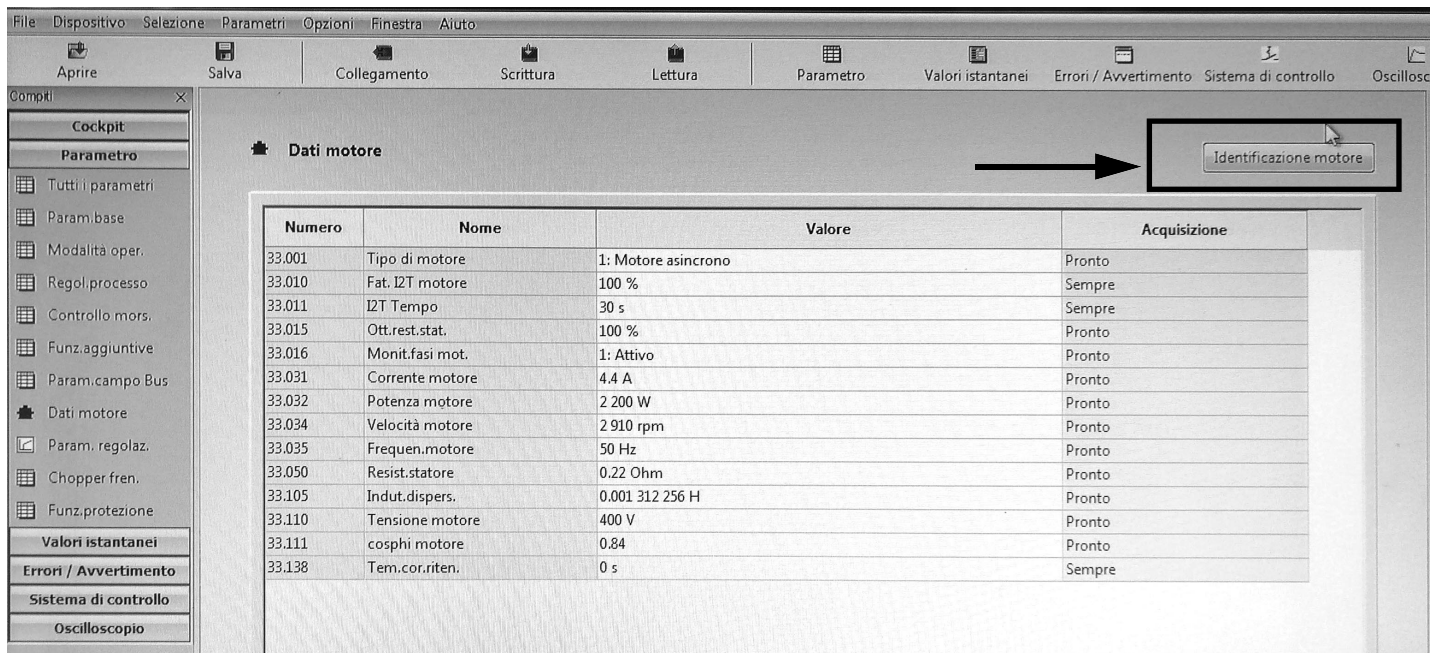

Parameter		
34.010	Control type	Open-loop asynchronous motor. Set value = 100 (open-loop asynchronous motor)
34.020	Flying restart	Set value = 1 (enabled)
34.021	Flying restart time	Calculated by Inverter. Set value = value calculated by INVERTER in ms
34.090	Speed controller Kp	Calculated by the inverter during the motor recognition phase. Reset it to 2000 after motor recognition. Set value = 2000 mA/rad/sec
34.091	Speed controller Tn	Calculated by the inverter during the motor recognition phase. Reset it to 7.5 seconds after motor recognition. Set value = 7.5 seconds
34.110	Slip trimmer	If set to 1 the function is enabled. If set to 0 the motor performs as if connected to the mains. If compensation is enabled, the system aligns the stator frequency with the rotor. As a result, the actual motor rpm increase and are brought in line with the theoretical motor nameplate rpm. The motor is supplied with the same voltage and frequency, but the current increases and the rpm are brought to the nameplate data. Set value = 1 (compensation for slippage)

Output signal variant for reading motor rpm (optional)

To have a 4-20 mA analogue output that indicates the motor rpm to the terminals X5-13 (Aout 0-20 mA) and X5-16 (A GND), set the parameters below:

Parameter		
4.100	Analogue output AO1	Selection of analogue output options. In our case, to have an output proportional to the rpm, set 19. Set value = 19 (actual rpm)
4.101	Minimum value of analogue output AO1	Output signal at 0-20 mA. To obtain a 4-20 mA signal with (4 mA = 0 motor rpm), follow the example: if motor rpm are a maximum 2900, calculate: $2900 / 20 \times 4 = 580$, which is the negative value corresponding to 0 mA from which to start. Therefore: 0 mA = - 580, 20 mA = 2900 Set value = - xxx (-580 in the example)
4.102	Maximum value of analogue output AO1	Maximum rpm value for 20 mA. Set value = xxxx (2900 in the above example)

NOTE 1	If the system enters pendulum mode with LMV.. / ETAMATIC, adjust parameters 34.090 and 34.091 by increasing them, in particular parameter 34.090 , in steps of 100mA/rad/sec.
NOTE 2	With LMV 2x/3x with INVERTER control, the device controls the standby rpm with param. 653 . If, after the fan is switched off, the device LMV 2x/3x sees that the motor continues to run, error 83 diagnostic 32 appears. This occurs if there is significant fan inertia (e.g. on burners with very heavy forward curved blades), then always disable parameter 653, setting it to 0 .
NOTE 3	With LMV 2x/3x the signal 0-10V for motor rpm control during standardisation is brought to approximately 9.7 V and the fan motor rpm is saved. According to the LMV manual, the INVERTER should be set to max 52.5 Hz During standardisation, the INVERTER is driven at approximately 51 ÷ 51.5 Hz and may go out of absorption range with the motor. For this reason, set the INVERTER to max 51.5 Hz. During standardisation, the INVERTER will reach 50Hz and the over-absorption problem will be reduced.
NOTE 4	If the <u>analogue wire break fault</u> is displayed on the INVERTER and the 4-20 mA inverter signal continues to oscillate between 1 ÷ 6 mA, it does not always mean that the LMV 2x/3x or ETAMATIC equipment is faulty. It could be due to the old firmware of the INVERTER and should therefore be updated. If this is the case, contact the Service Centre.

FAULTS / PROBLEMS.. SOLUTIONS		
Parameter 36.020	If error 36 appears	Problems detected in the mains supply. By setting this parameter to 0, the INVERTER no longer checks the mains and the error message disappears. It is recommended to leave the parameter set to 1.
Parameter 33.105	If mains voltage drops during operation	When the mains voltage drops, the INVERTER decreases the motor rpm. To reduce this change, set the parameter to 0, which should solve the problem.

Brake chopper connections

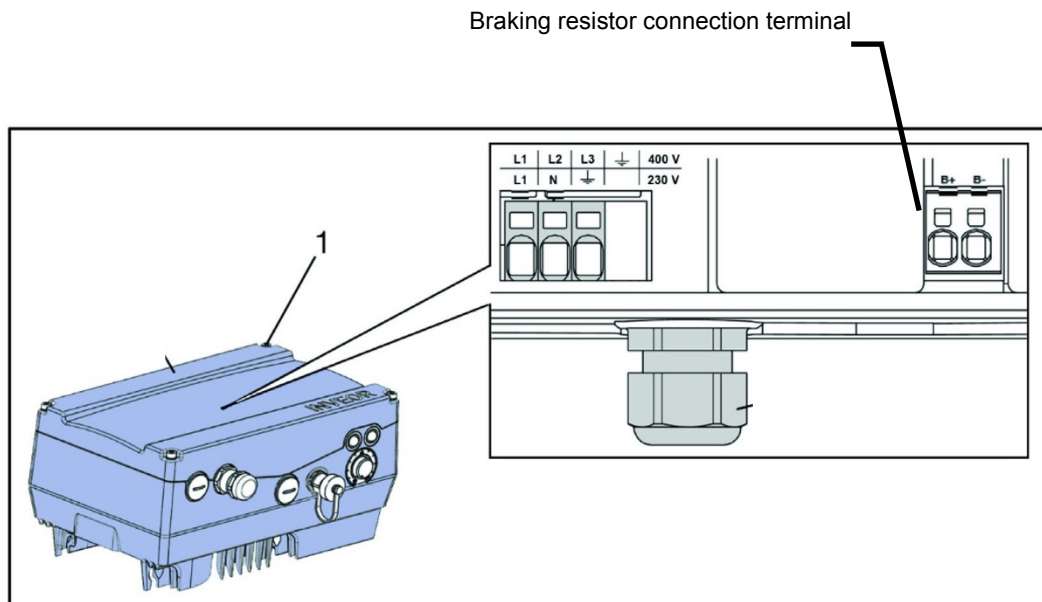

Brake chopper connections

Terminal no.	Designation	Assignment
1	B+	Braking resistor connection (+)
2	B-	Braking resistor connection (-)

Optional assignment of brake chopper

Parameter	
Braking resistor	Enabled or disabled

Braking resistors



Burner terminal block with interface INVERTER

Versioni bruciatore con LMV2x/3x

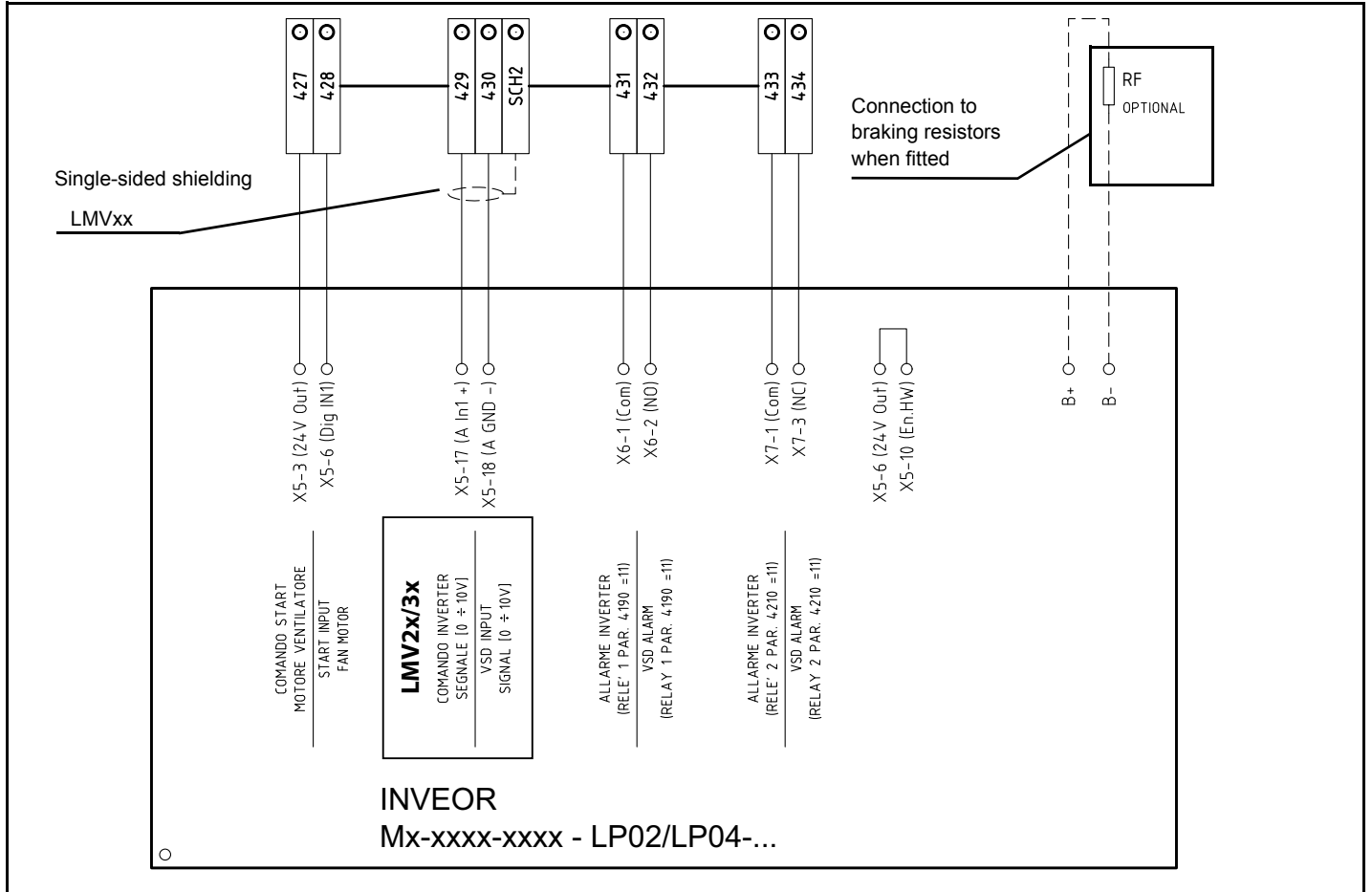

Versioni bruciatore con LMV5x o ETAMATIC

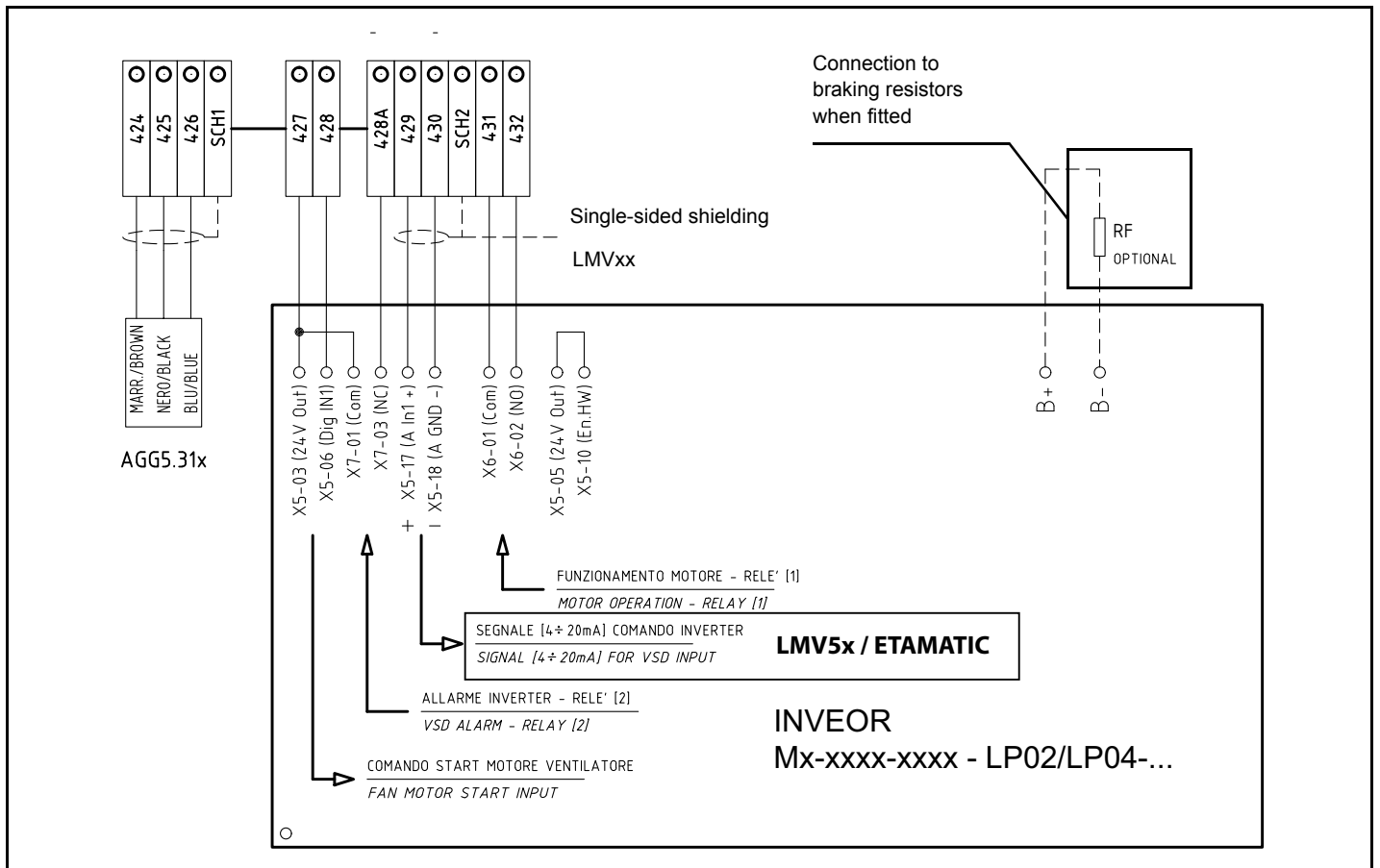



C.I.B. UNIGAS S.p.A.
Via L.Galvani, 9 - 35011 Campodarsego (PD) - ITALY
Tel. +39 049 9200944 - Fax +39 049 9200945/9201269
web site: www.cibunigas.it - e-mail: cibunigas@cibunigas.it

Note: specifications and data subject to change. Errors and omissions excepted.