

HR91A
HR92A
HR93A
HR512A
HR515A
HR520A
HR525A

Gas - Light oil burners

MANUAL OF INSTALLATION - USE - MAINTENANCE

CIB UNIGAS

BURNERS - BRUCIATORI - BRULERS - BRENNER - QUEMADORES - ГОРЕЛКИ

DANGERS, WARNINGS AND NOTES OF CAUTION

THIS MANUAL IS SUPPLIED AS AN INTEGRAL AND ESSENTIAL PART OF THE PRODUCT AND MUST BE DELIVERED TO THE USER.

INFORMATION INCLUDED IN THIS SECTION ARE DEDICATED BOTH TO THE USER AND TO PERSONNEL FOLLOWING PRODUCT INSTALLATION AND MAINTENANCE.

THE USER WILL FIND FURTHER INFORMATION ABOUT OPERATING AND USE RESTRICTIONS, IN THE SECOND SECTION OF THIS MANUAL. WE HIGHLY RECOMMEND TO READ IT.

CAREFULLY KEEP THIS MANUAL FOR FUTURE REFERENCE.

1) GENERAL INTRODUCTION

- The equipment must be installed in compliance with the regulations in force, following the manufacturer's instructions, by qualified personnel.
- Qualified personnel means those having technical knowledge in the field of components for civil or industrial heating systems, sanitary hot water generation and particularly service centres authorised by the manufacturer.
- Improper installation may cause injury to people and animals, or damage to property, for which the manufacturer cannot be held liable.
- Remove all packaging material and inspect the equipment for integrity. In case of any doubt, do not use the unit - contact the supplier.

The packaging materials (wooden crate, nails, fastening devices, plastic bags, foamed polystyrene, etc), should not be left within the reach of children, as they may prove harmful.

- Before any cleaning or servicing operation, disconnect the unit from the mains by turning the master switch OFF, and/or through the cut-out devices that are provided.
- Make sure that inlet or exhaust grilles are unobstructed.
- In case of breakdown and/or defective unit operation, disconnect the unit. Make no attempt to repair the unit or take any direct action.

Contact qualified personnel only.

Units shall be repaired exclusively by a servicing centre, duly authorised by the manufacturer, with original spare parts and accessories.

Failure to comply with the above instructions is likely to impair the unit's safety.

To ensure equipment efficiency and proper operation, it is essential that maintenance operations are performed by qualified personnel at regular intervals, following the manufacturer's instructions.

- When a decision is made to discontinue the use of the equipment, those parts likely to constitute sources of danger shall be made harmless.
- In case the equipment is to be sold or transferred to another user, or in case the original user should move and leave the unit behind, make sure that these instructions accompany the equipment at all times so that they can be consulted by the new owner and/or the installer.
- This unit shall be employed exclusively for the use for which it is meant. Any other use shall be considered as improper and, therefore, dangerous.

The manufacturer shall not be held liable, by agreement or otherwise, for damages resulting from improper installation, use and failure to comply with the instructions supplied by the manufacturer. The occurrence of any of the following circumstances may cause explosions, polluting unburnt gases (example: carbon monoxide CO), burns, serious harm to people, animals and things:

- Failure to comply with one of the WARNINGS in this chapter
- Incorrect handling, installation, adjustment or maintenance of the burner
- Incorrect use of the burner or incorrect use of its parts or optional supply

2) SPECIAL INSTRUCTIONS FOR BURNERS

- The burner should be installed in a suitable room, with ventilation openings complying with the requirements of the regulations in force, and sufficient for good combustion.
- Only burners designed according to the regulations in force should be used.
- This burner should be employed exclusively for the use for which it was designed.
- Before connecting the burner, make sure that the unit rating is the same as delivery mains (electricity, gas oil, or other fuel).
- Observe caution with hot burner components. These are, usually, near to the flame and the fuel pre-heating system, they become hot during the unit operation and will remain hot for some time after the burner has stopped.

When the decision is made to discontinue the use of the burner, the user shall have qualified personnel carry out the following operations:

- a Remove the power supply by disconnecting the power cord from the mains.
- b Disconnect the fuel supply by means of the hand-operated shut-off valve and remove the control handwheels from their spindles.

Special warnings

- Make sure that the burner has, on installation, been firmly secured to the appliance, so that the flame is generated inside the appliance fire-box.
- Before the burner is started and, thereafter, at least once a year, have qualified personnel perform the following operations:
 - a set the burner fuel flow rate depending on the heat input of the appliance;
 - b set the flow rate of the combustion-supporting air to obtain a combustion efficiency level at least equal to the lower level required by the regulations in force;
 - c check the unit operation for proper combustion, to avoid any harmful or polluting unburnt gases in excess of the limits permitted by the regulations in force;
 - d make sure that control and safety devices are operating properly;
 - e make sure that exhaust ducts intended to discharge the products of combustion are operating properly;
 - f on completion of setting and adjustment operations, make sure that all mechanical locking devices of controls have been duly tightened;
 - g make sure that a copy of the burner use and maintenance instructions is available in the boiler room.
- In case of a burner shut-down, reset the control box by means of the RESET pushbutton. If a second shut-down takes place, call the Technical Service, **without trying to RESET further**.
- The unit shall be operated and serviced by qualified personnel only, in compliance with the regulations in force.

3) GENERAL INSTRUCTIONS DEPENDING ON FUEL USED

3a) ELECTRICAL CONNECTION

- For safety reasons the unit must be efficiently earthed and installed as required by current safety regulations.
- It is vital that all safety requirements are met. In case of any doubt, ask for an accurate inspection of electrics by qualified personnel, since the manufacturer cannot be held liable for damages that may be caused by failure to correctly earth the equipment.
- Qualified personnel must inspect the system to make sure that it is adequate to take the maximum power used by the equipment shown on the equipment rating plate. In particular, make sure that the system cable cross section is adequate for the power absorbed by the unit.
- No adaptors, multiple outlet sockets and/or extension cables are permitted to connect the unit to the electric mains.
- An omnipolar switch shall be provided for connection to mains, as required by the current safety regulations.
- The use of any power-operated component implies observance of a few basic rules, for example:
 - do not touch the unit with wet or damp parts of the body and/or with bare feet;
 - do not pull electric cables;
 - do not leave the equipment exposed to weather (rain, sun, etc.) unless expressly required to do so;
 - do not allow children or inexperienced persons to use equipment;
- The unit input cable shall not be replaced by the user. In case of damage to the cable, switch off the unit and contact qualified personnel to replace. When the unit is out of use for some time the electric switch supplying all the power-driven components in the system (i.e. pumps, burner, etc.) should be switched off.

3b) FIRING WITH GAS, LIGHT OIL OR OTHER FUELS

GENERAL

- The burner shall be installed by qualified personnel and in compliance with regulations and provisions in force; wrong installation can cause injuries to people and animals, or damage to property, for which the manufacturer cannot be held liable.
- Before installation, it is recommended that all the fuel supply system pipes be carefully cleaned inside, to remove foreign matter that might impair the burner operation.
- Before the burner is commissioned, qualified personnel should inspect the following:
 - a the fuel supply system, for proper sealing;
 - b the fuel flow rate, to make sure that it has been set based on the firing rate required of the burner;
 - c the burner firing system, to make sure that it is supplied for the designed fuel type;
 - d the fuel supply pressure, to make sure that it is included in the range shown on the rating plate;
 - e the fuel supply system, to make sure that the system dimensions are adequate to the burner firing rate, and that the system is equipped with all the safety and control devices required by the regulations in force.
- When the burner is to remain idle for some time, the fuel supply tap or taps should be closed.

SPECIAL INSTRUCTIONS FOR USING GAS

Have qualified personnel inspect the installation to ensure that:

- a the gas delivery line and train are in compliance with the regulations and provisions in force;
 - b all gas connections are tight;
 - c the boiler room ventilation openings are such that they ensure the air supply flow required by the current regulations, and in any case are sufficient for proper combustion.
- Do not use gas pipes to earth electrical equipment.
 - Never leave the burner connected when not in use. Always shut the gas valve off.
 - In case of prolonged absence of the user, the main gas delivery valve to the burner should be shut off.

Precautions if you can smell gas

- a do not operate electric switches, the telephone, or any other item likely to generate sparks;
 - b immediately open doors and windows to create an air flow to purge the room;
 - c close the gas valves;
 - d contact qualified personnel.
- Do not obstruct the ventilation openings of the room where gas appliances are installed, to avoid dangerous conditions such as the development of toxic or explosive mixtures.

DIRECTIVES AND STANDARDS

Gas burners

European directives

- Regulation 2016/426/UE (appliances burning gaseous fuels)
- 2014/35/UE (Low Tension Directive)
- 2014/30/UE (Electromagnetic compatibility Directive)
- 2006/42/EC (Machinery Directive)

Harmonized standards

- UNI EN 676 (Automatic forced draught burners for gaseous fuels)
- EN 55014-1 (Electromagnetic compatibility- Requirements for household appliances, electric tools and similar apparatus)
- EN 60204-1:2006 (Safety of machinery – Electrical equipment of machines.)
- CEI EN 60335-1 (Specification for safety of household and similar electrical appliances);
- CEI EN 60335-2-102 (Household and similar electrical appliances. Safety. Particular requirements for gas, oil and solid-fuel burning appliances having electrical connections).
- UNI EN ISO 12100:2010 (Safety of machinery - General principles for design - Risk assessment and risk reduction);

Light oil burners

European directives

- 2014/35/UE (Low Tension Directive)
- 2014/30/UE (Electromagnetic compatibility Directive)
- 2006/42/EC (Machinery Directive)

Harmonized standards

- UNI EN 267-2011 (Automatic forced draught burners for liquid fuels)
- EN 55014-1 (Electromagnetic compatibility- Requirements for household appliances, electric tools and similar apparatus)
- EN 60204-1:2006 (Safety of machinery – Electrical equipment of machines.)
- CEI EN 60335-1 (Specification for safety of household and similar electrical appliances);
- CEI EN 60335-2-102 (Household and similar electrical appliances. Safety. Particular requirements for gas, oil and solid-fuel burning appliances having electrical connections).
- UNI EN ISO 12100:2010 (Safety of machinery - General principles for design - Risk assessment and risk reduction);

National Standard

- UNI 7824 (Atomizing burners of the monobloc type. Characteristics and test methods)

Heavy oil burners

European Directives

- 2014/35/UE (Low Tension Directive)
- 2014/30/UE (Electromagnetic compatibility Directive)
- 2006/42/EC (Machinery Directive)

Harmonized standards

- UNI EN 267 (Automatic forced draught burners for liquid fuels)
- EN 55014-1 (Electromagnetic compatibility- Requirements for household appliances, electric tools and similar apparatus)
- EN 60204-1:2006 (Safety of machinery – Electrical equipment of machines.)
- CEI EN 60335-1 (Specification for safety of household and similar electrical appliances);
- CEI EN 60335-2-102 (Household and similar electrical appliances. Safety. Particular requirements for gas, oil and solid-fuel burning appliances having electrical connections).
- UNI EN ISO 12100:2010 (Safety of machinery - General principles for design - Risk assessment and risk reduction);

Norme nazionali / National Standard

- UNI 7824 (Atomizing burners of the monobloc type. Characteristics and test methods).

Gas - Light oil burners

European Directives

- Regulation 2016/426/UE (appliances burning gaseous fuels)
- 2014/35/UE (Low Tension Directive)
- 2014/30/UE (Electromagnetic compatibility Directive)
- 2006/42/EC (Machinery Directive)

Harmonized standards

- UNI EN 676 (Automatic forced draught burners for gaseous fuels)
- UNI EN 267 (Automatic forced draught burners for liquid fuels)
- EN 55014-1 (Electromagnetic compatibility- Requirements for household appliances, electric tools and similar apparatus)
- EN 60204-1:2006 (Safety of machinery – Electrical equipment of machines.)
- CEI EN 60335-1 (Specification for safety of household and similar electrical appliances);
- CEI EN 60335-2-102 (Household and similar electrical appliances. Safety. Particular requirements for gas, oil and solid-fuel burning appliances having electrical connections).
- UNI EN ISO 12100:2010 (Safety of machinery - General principles for design - Risk assessment and risk reduction);

Norme nazionali / National Standard

- UNI 7824 (Atomizing burners of the monobloc type. Characteristics and test methods.

Gas - Heavy oil burners

European directives:

- Regulation 2016/426/UE (appliances burning gaseous fuels)
- 2014/35/UE (Low Tension Directive)
- 2014/30/UE (Electromagnetic compatibility Directive)
- 2006/42/EC (Machinery Directive)

Harmonized standards

- UNI EN 676 (Automatic forced draught burners for gaseous fuels)
- EN 55014-1 (Electromagnetic compatibility- Requirements for household appliances, electric tools and similar apparatus)
- EN 60204-1:2006 (Safety of machinery – Electrical equipment of machines.)
- CEI EN 60335-1 (Specification for safety of household and similar electrical appliances);
- CEI EN 60335-2-102 (Household and similar electrical appliances. Safety. Particular requirements for gas, oil and solid-fuel burning appliances having electrical connections).
- UNI EN ISO 12100:2010 (Safety of machinery - General principles for design - Risk assessment and risk reduction);

National Standard

- UNI 7824 (Atomizing burners of the monobloc type. Characteristics and test methods.

Industrial burners

European directives

- Regulation 2016/426/UE (appliances burning gaseous fuels)
- 2014/35/UE (Low Tension Directive)
- 2014/30/UE (Electromagnetic compatibility Directive)
- 2006/42/EC (Machinery Directive)

Harmonized standards

- EN 55014-1 (Electromagnetic compatibility- Requirements for household appliances, electric tools and similar apparatus)
- EN 746-2 (Industrial thermoprocessing equipment - Part 2: Safety requirements for combustion and fuel handling systems)
- UNI EN ISO 12100:2010 (Safety of machinery - General principles for design - Risk assessment and risk reduction);
- EN 60204-1:2006 (Safety of machinery – Electrical equipment of machines.)
- EN 60335-2 (Electrical equipment of non-electric appliances for household and similar purposes. Safety requirements)

Burner data plate

For the following information, please refer to the data plate:

- burner type and burner model: must be reported in any communication with the supplier
- burner ID (serial number): must be reported in any communication with the supplier
- date of production (year and month)
- information about fuel type and network pressure

| | |
|--------------|----|
| Type | -- |
| Model | -- |
| Year | -- |
| S.Number | -- |
| Output | -- |
| Oil Flow | -- |
| Fuel | -- |
| Category | -- |
| Gas Pressure | -- |
| Viscosity | -- |
| El.Supply | -- |
| El.Consump. | -- |
| Fan Motor | -- |
| Protection | -- |
| Drwaing n° | -- |
| P.I.N. | -- |

SYMBOLS USED



WARNING!

Failure to observe the warning may result in irreparable damage to the unit or damage to the environment



DANGER!

Failure to observe the warning may result in serious injuries or death.



WARNING!

Failure to observe the warning may result in electric shock with lethal consequences

Figures, illustrations and images used in this manual may differ in appearance from the actual product.

PART I: SPECIFICATIONS

BURNERS FEATURES

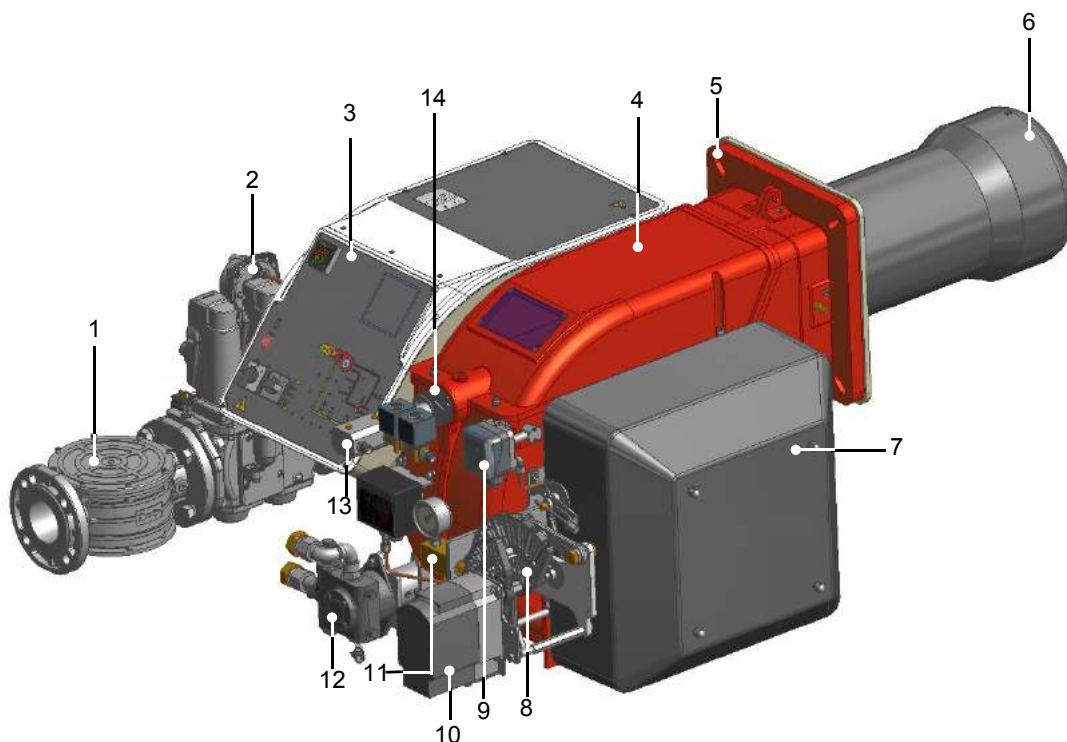

Note: the figure is indicative only

Keys

- 1 Gas filter
- 2 Gas valve group
- 3 Mimic panel with startup switch
- 4 Cover
- 5 Flange
- 6 Blast tube-Combustion head group
- 7 Air intake
- 8 Adjusting cams
- 9 Air pressure switch
- 10 Actuator
- 11 Oil pressure governor
- 12 Pump
- 13 Oil manifold
- 14 Head adjusting ring nut

Gas operation: the gas coming from the supply line, passes through the valves group provided with filter and governor. This one forces the pressure in the utilisation limits. The actuators move proportionally the air damper and the gas butterfly valve, in order to achieve the optimisation of the gas flue values, as to get an efficient combustion.

Light oil operation: the fuel coming from the supply line, is pushed by the pump to the nozzle and then into the combustion chamber, where the mixture between fuel and air takes place and consequently the flame.

In the burners, the mixture between fuel and air, to perform clean and efficient combustion, is activated by atomisation of oil into very small particles. This process is achieved making pressurised oil passing through the nozzle.

The pump main function is to transfer oil from the tank to the nozzle in the desired quantity and pressure. To adjust this pressure, pumps are provided with a pressure regulator (except for some models for which a separate regulating valve is provided). Other pumps are provided with two pressure regulators: one for the high and one for low pressure (in double-stage systems with one nozzle).

The adjustable combustion head can improve the burner performance. The combustion head determines the energetic quality and the geometry of the flame. Fuel and comburent are routed into separated ways as far as the zone of flame generation (combustion chamber). The control panel, placed on the burner front side, shows each operating stage.

Burner model identification

Burners are identified by burner type and model. Burner model identification is described as follows.

Type **HR512A** Model **MG. MD. S. *. A. 1. 80.**
(1) (2) (3) (4) (5) (6) (7) (8)

| | | |
|---|--------------------------------|--|
| 1 | BURNER TYPE | HR91A, HR92A, HR93A, HR512A, HR515A, HR520A, HR525A |
| 2 | FUEL | M - Natural gas L - LPG G - Light oil |
| 3 | OPERATION (Available versions) | PR - Progressive MD - Fully modulating |
| 4 | BLAST TUBE | S - Standard |
| 5 | DESTINATION COUNTRY | * - see data plate |
| 6 | BURNER VERSION | A - Standard Y - SpecialeSpecial |
| 7 | EQUIPMENT | 1 = 2 gas valves + gas proving system 8 = 2 gas valves + gas proving system + maximum gas pressure switch |
| 8 | GAS CONNECTION | 50 = Rp2 65 = DN65 80 = DN80 100 = DN100 |

Technical Specifications

| BURNER TYPE | | HR91A MG.. | HR92A MG.. | HR93A MG.. |
|--------------------------------|----------------------------------|----------------------------------|------------|------------|
| Output | min. - max. kW | 480 - 2670 | 480 - 3050 | 550 - 4100 |
| Fuel | | Natural gas - Light oil | | |
| Category | | (see next paragraph) | | |
| Gas rate- Natural gas | min.- max. (Stm ³ /h) | 51 - 283 | 51 - 323 | 58 - 434 |
| Gas pressure | mbar | (see Note 2) | | |
| Light oil rate | min.-max. kg/h | 40 - 225 | 40 - 257 | 46 - 345 |
| Oil viscosity | cSt @ 40°C | 2 - 7.4 | | |
| Oil density | kg/m ³ | 840 | | |
| Light oil train inlet pressure | bar max | 2 | | |
| Power supply triphase | | 220V/230V 3~ / 380V/400V 3N ~ 50 | | |
| Auxiliary Power supply | | 220V/230V 2~ / 220V/230V 1N ~ 50 | | |
| Total power consumption | kW | 5.6 | 7.1 | 9.1 |
| Electric motor | kW | 4 | 5.5 | 7.5 |
| Pump motor | kW | 1.1 | 1.1 | 1.1 |
| Protection | | IP40 | | |
| Operation | | Progressive - Fully modulating | | |
| Gas train 50 | Valves size / Gas connection | 50 / Rp 2 | | |
| Gas train 65 | Valves size / Gas connection | 65 / DN65 | | |
| Gas train 80 | Valves size / Gas connection | 80 / DN80 | | |
| Gas train 100 | Valves size / Gas connection | 100 / DN100 | | |
| Operating temperature | °C | -10 ÷ +50 | | |
| Storage Temperature | °C | -20 ÷ +60 | | |
| Working service (*) | | Intermitent | | |

| | |
|---------------|--|
| Note1: | All gas flow rates are referred to Stm ³ /h (1013 mbar absolute pressure, 15 °C temperature) and are valid for G20 gas (net calorific value H _i = 34.02 MJ/Stm ³); for L.P.G. (net calorific value H _i = 93.5 MJ/Stm ³) |
| Note2: | Maximum gas pressure = 500mbar (with Siemens VGD or Dungs MultiBloc MBE) Minimum gas pressure = see gas curves. |
| Note3: | Burners are suitable only for indoor operation with a maximum relative humidity of 80% |

(*) **NOTE ON THE WORKING SERVICE:** the control box automatically stops after 24h of continuous working. The control box immediately starts up, automatically.

| BURNER TYPE | | HR91A LG.. | HR92A LG.. | HR93A LG.. |
|--------------------------------|----------------------------------|----------------------------------|------------|------------|
| Output | min. - max. kW | 480 - 2670 | 480 - 3050 | 550 - 4100 |
| Fuel | | L.P.G. - Light oil | | |
| Category | | I _{3B/P} | | |
| Gas rate- LPG | min.- max. (Stm ³ /h) | 17.9 - 100 | 17.9 - 114 | 20 - 153 |
| Gas pressure | mbar | (see Note 2) | | |
| Light oil rate | min.-max. kg/h | 40 - 225 | 40 - 257 | 46 - 345 |
| Oil viscosity | cSt @ 40°C | 2 - 7.4 | | |
| Oil density | kg/m ³ | 840 | | |
| Light oil train inlet pressure | bar max | 2 | | |
| Power supply triphase | | 220V/230V 3~ / 380V/400V 3N ~ 50 | | |
| Auxiliary Power supply | | 220V/230V 2~ / 220V/230V 1N ~ 50 | | |
| Total power consumption | kW | 5.6 | 7.1 | 9.1 |
| Electric motor | kW | 4 | 5.5 | 7.5 |
| Pump motor | kW | 1.1 | 1.1 | 1.1 |
| Protection | | IP40 | | |
| Operation | | Progressive - Fully modulating | | |
| Gas train 50 | Valves size / Gas connection | 50 / Rp 2 | | |
| Gas train 65 | Valves size / Gas connection | 65 / DN65 | | |
| Gas train 80 | Valves size / Gas connection | 80 / DN80 | | |
| Gas train 100 | Valves size / Gas connection | 100 / DN100 | | |
| Operating temperature | °C | -10 ÷ +50 | | |
| Storage Temperature | °C | -20 ÷ +60 | | |
| Working service (*) | | Intermittent | | |

| BURNER TYPE | | HR512A MG.. | HR515A MG.. | HR520A MG.. | HR525A...50 MG.. | HR525A...xx MG.. |
|--------------------------------|----------------------------------|----------------------------------|-------------|-------------|------------------|------------------|
| Output | min. - max. kW | 600 - 4500 | 770 - 5200 | 1000 - 6400 | 2000 - 6700 | 2000 - 8000 |
| Fuel | | Natural gas - Light oil | | | | |
| Category | | (see next paragraph) | | | | |
| Gas rate- Natural gas | min.- max. (Stm ³ /h) | 63 - 476 | 81 - 550 | 106 - 677 | 212 - 709 | 212 - 847 |
| Gas pressure | mbar | (see Note 2) | | | | |
| Light oil rate | min.-max. kg/h | 50 - 379 | 65 - 438 | 84 - 539 | 168 - 564 | 168 - 674 |
| Oil viscosity | | 2 - 7.4 cSt @ 40°C | | | | |
| Oil density | kg/m ³ | 840 | | | | |
| Light oil train inlet pressure | bar max | 2 | | | | |
| Power supply triphase | | 220V/230V 3~ / 380V/400V 3N ~ 50 | | | 400V 3N ~ 50Hz | |
| Auxiliary Power supply | | 220V/230V 2~ / 220V/230V 1N ~ 50 | | | 400V 3N ~ 50Hz | |
| Total power consumption | kW | 10.8 | 13 | 17 | 22 | 22 |
| Electric motor | kW | 9.2 | 11 | 15 | 18.5 | 18.5 |
| Pump motor | kW | 1.1 | 1.5 | 1.5 | 3 | 3 |
| Protection | | IP40 | | | | |
| Operation | | Progressive - Fully modulating | | | | |
| Gas train 50 | Valves size / Gas connection | 50 / Rp2 | 50 / Rp2 | 50 / Rp2 | 50 / Rp2 | |
| Gas train 65 | Valves size / Gas connection | 65 / DN65 | 65 / DN65 | 65 / DN65 | - | 65 / DN65 |
| Gas train 80 | Valves size / Gas connection | 80 / DN80 | 80 / DN80 | 80 / DN80 | - | 80 / DN80 |
| Gas train 100 | Valves size / Gas connection | 100 / DN100 | 100 / DN100 | 100 / DN100 | - | 100 / DN100 |
| Operating temperature | °C | -10 ÷ +50 | | | | |
| Storage Temperature | °C | -20 ÷ +60 | | | | |
| Working service (*) | | Intermittent | | | | |

| | |
|---------------|--|
| Note1: | All gas flow rates are referred to Stm ³ /h (1013 mbar absolute pressure, 15 °C temperature) and are valid for G20 gas (net calorific value H _i = 34.02 MJ/Stm ³); for L.P.G. (net calorific value H _i = 93.5 MJ/Stm ³) |
| Note2: | Maximum gas pressure = 500mbar (with Siemens VGD or Dungs MultiBloc MBE) Minimum gas pressure = see gas curves. |
| Note3: | Burners are suitable only for indoor operation with a maximum relative humidity of 80% |

(*) **NOTE ON THE WORKING SERVICE:** the control box automatically stops after 24h of continuous working. The control box immediately starts up, automatically.

| BURNER TYPE | | HR512A LG.. | HR515A LG.. | HR520A LG.. | HR525A...50 LG.. | HR525A...xx LG.. |
|--------------------------------|---|----------------------------------|-------------|-------------|------------------|------------------|
| Output | min. - max. kW | 600 - 4500 | 770 - 5200 | 1000 - 6400 | 2000 - 6700 | 2000 - 8000 |
| Fuel | | L.P.G. - Light oil | | | | |
| Category | | I _{3B/P} | | | | |
| Gas rate- LPG | min.- max. (Stm ³ /h) | 22 - 167 | 28 - 194 | 37 - 238 | 74 - 250 | 74 - 300 |
| Gas pressure | mbar | (see Note 2) | | | | |
| Light oil rate | min.-max. kg/h | 50 - 379 | 65 - 438 | 84 - 539 | 168 - 564 | 168 - 674 |
| Oil viscosity | | 2 - 7.4 cSt @ 40°C | | | | |
| Oil density | kg/m ³ | 840 | | | | |
| Light oil train inlet pressure | bar max | 2 | | | | |
| Power supply triphase | | 220V/230V 3~ / 380V/400V 3N ~ 50 | | | 400V 3N ~ 50Hz | |
| Auxiliary Power supply | | 220V/230V 2~ / 220V/230V 1N ~ 50 | | | 400V 3N ~ 50Hz | |
| Total power consumption | kW | 10.8 | 13 | 17 | 22 | 22 |
| Electric motor | kW | 9.2 | 11 | 15 | 18.5 | 18.5 |
| Pump motor | kW | 1.1 | 1.5 | 1.5 | 3 | 3 |
| Protection | | IP40 | | | | |
| Operation | | Progressive - Fully modulating | | | | |
| Gas train 50 | Valves size / Gas connection | 50 / Rp2 | 50 / Rp2 | 50 / Rp2 | 50 / Rp2 | |
| Gas train 65 | Valves size / Gas connection | 65 / DN65 | 65 / DN65 | 65 / DN65 | - | 65 / DN65 |
| Gas train 80 | Valves size / Gas connection | 80 / DN80 | 80 / DN80 | 80 / DN80 | - | 80 / DN80 |
| Gas train 100 | Valves size / Gas connection | 100 / DN100 | 100 / DN100 | 100 / DN100 | - | 100 / DN100 |
| Operating temperature | °C | -10 ÷ +50 | | | | |
| Storage Temperature | °C | -20 ÷ +60 | | | | |
| Working service (*) | | Intermittent | | | | |
| Note1: | All gas flow rates are referred to Stm³/h (1013 mbar absolute pressure, 15 °C temperature) and are valid for G20 gas (net calorific value H_i = 34.02 MJ/Stm³); for L.P.G. (net calorific value H_i = 93.5 MJ/Stm³) | | | | | |
| Note2: | Maximum gas pressure = 500mbar (with Siemens VGD or Dungs MultiBloc MBE) Minimum gas pressure = see gas curves. | | | | | |
| Note3: | Burners are suitable only for indoor operation with a maximum relative humidity of 80% | | | | | |

(*) **NOTE ON THE WORKING SERVICE:** the control box automatically stops after 24h of continuous working. The control box immediately starts up, automatically.

Country and usefulness gas categories

| GAS CATEGORY | COUNTRY | | | | | | | | | | | | | | | | | | | | | | | | | |
|----------------------|---------|----|----|----|----|----|----|----|----|----|----|----|----|----|----|----|----|----|----|----|----|----|----|----|----|---|
| | AT | ES | GR | SE | FI | IE | HU | IS | NO | CZ | DK | GB | IT | PT | CY | EE | LV | SI | MT | SK | BG | LT | RO | TR | CH | |
| I _{2H} | | | | | | | | | | | | | | | | | | | | | | | | | | |
| I _{2E} | LU | PL | - | - | - | - | - | - | - | - | - | - | - | - | - | - | - | - | - | - | - | - | - | - | - | - |
| I _{2E(R)B} | BE | - | - | - | - | - | - | - | - | - | - | - | - | - | - | - | - | - | - | - | - | - | - | - | - | - |
| (*) I _{2EK} | NL | - | - | - | - | - | - | - | - | - | - | - | - | - | - | - | - | - | - | - | - | - | - | - | - | - |
| I _{2ELL} | DE | - | - | - | - | - | - | - | - | - | - | - | - | - | - | - | - | - | - | - | - | - | - | - | - | - |
| I _{2Er} | FR | - | - | - | - | - | - | - | - | - | - | - | - | - | - | - | - | - | - | - | - | - | - | - | - | - |

(*) **Only for I_{2EK}** : the appliance was configured for the appliance category K (I2K) and is suitable for the use of G and G+ distribution gases according to the specifications as included in the NTA 8837:2012 Annex D with a Wobbe index of 43.46 – 45.3 MJ/m³ (dry, 0 °C, upper value) or 41.23 – 42.98 (dry, 15 °C, upper value). This appliance can moreover be converted and/or be calibrated for the appliance category E (I2E). This therefore implies that the appliance "is suitable for G+ gas and H gas or is demonstrably suitable for G+ gas and can demonstrably be made suitable for H gas" within the meaning of the "Dutch Decree of 10 May 2016 regarding amendment of the Dutch Gas Appliances Decree and the Dutch Commodities (Administrative Fines) Act in connection with the changing composition of gas in the Netherlands as well as technical amendment of some other decrees.

Fuel



DANGER! The burner must be used only with the fuel specified in the burner data plate.

| | |
|--------------|----|
| Type | -- |
| Model | -- |
| Year | -- |
| S.Number | -- |
| Output | -- |
| Oil Flow | -- |
| Fuel | -- |
| Category | -- |
| Gas Pressure | -- |
| Viscosity | -- |
| El.Supply | -- |
| El.Consump. | -- |

Overall dimensions (mm)

B*: SPECIAL BLAST TUBE LENGTHS MUST BE AGREED WITH CIB UNIGAS

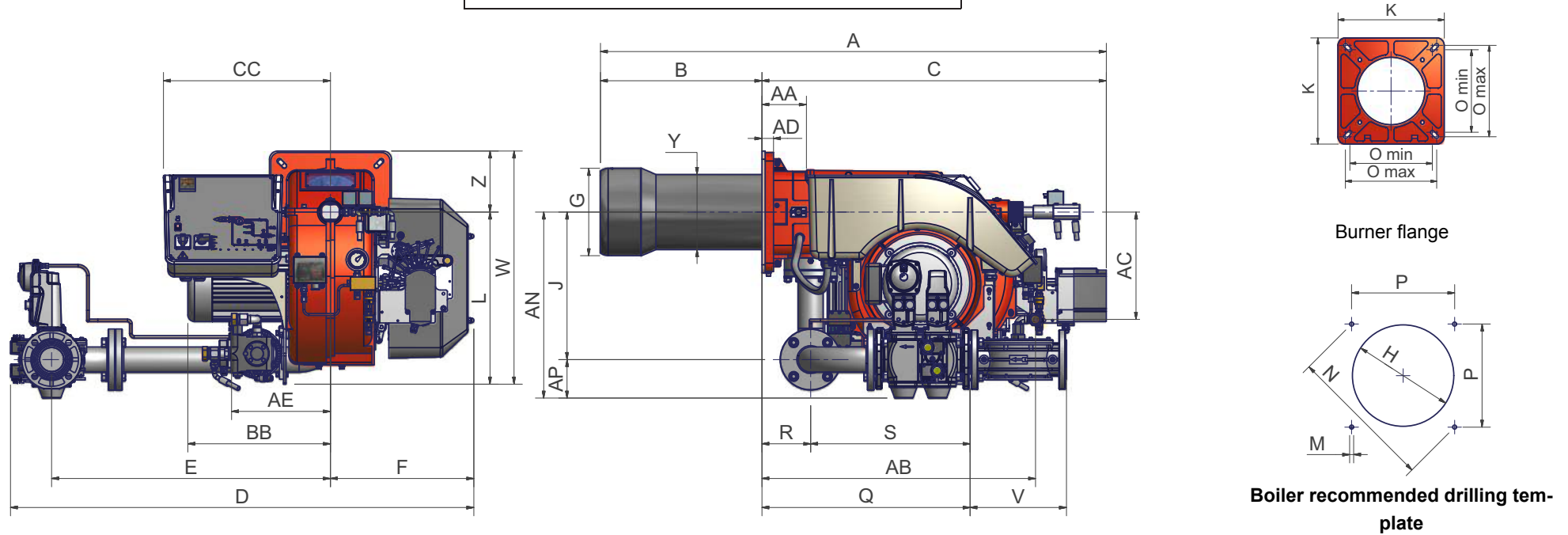

| | DN* | A | AA | AB | AC | AD | AE | AN | AP | B | BB | C | CC | D | E | F | G | H | I | J | K | L | M | N | Omin | Omax | P | Q | R | S | U | V | W | Y | Z |
|-------|-----|------|-----|-----|-----|----|-----|-----|-----|-----|-----|------|-----|------|------|-----|-----|-----|-----|-----|-----|-----|-----|-----|------|------|-----|-----|-----|-----|-----|-----|-----|-----|-----|
| HR91A | 50 | 1535 | 135 | 831 | 327 | 35 | 300 | 550 | 100 | 490 | 441 | 1045 | 507 | 1160 | 725 | 435 | 265 | 295 | 228 | 450 | 360 | 523 | M12 | 424 | 280 | 310 | 300 | 532 | 148 | 384 | 624 | 190 | 708 | 228 | 185 |
| | 65 | 1535 | 135 | 831 | 327 | 35 | 300 | 564 | 117 | 490 | 441 | 1045 | 507 | 1406 | 971 | 435 | 265 | 295 | 228 | 447 | 360 | 523 | M12 | 424 | 280 | 310 | 300 | 632 | 148 | 484 | 846 | 292 | 708 | 228 | 185 |
| | 80 | 1535 | 135 | 831 | 327 | 35 | 300 | 579 | 132 | 490 | 441 | 1045 | 507 | 1437 | 1002 | 435 | 265 | 295 | 228 | 447 | 360 | 523 | M12 | 424 | 280 | 310 | 300 | 683 | 148 | 535 | 875 | 313 | 708 | 228 | 185 |
| | 100 | 1535 | 135 | 831 | 327 | 35 | 300 | 592 | 145 | 490 | 441 | 1045 | 507 | 1520 | 1085 | 435 | 265 | 295 | 228 | 447 | 360 | 523 | M12 | 424 | 280 | 310 | 300 | 790 | 148 | 642 | 942 | 353 | 708 | 228 | 185 |
| HR92A | 50 | 1535 | 135 | 831 | 327 | 35 | 300 | 550 | 100 | 490 | 441 | 1045 | 507 | 1160 | 725 | 435 | 269 | 299 | 228 | 450 | 360 | 523 | M12 | 424 | 280 | 310 | 300 | 532 | 148 | 384 | 624 | 190 | 708 | 228 | 185 |
| | 65 | 1535 | 135 | 831 | 327 | 35 | 300 | 564 | 117 | 490 | 441 | 1045 | 507 | 1406 | 971 | 435 | 269 | 299 | 228 | 447 | 360 | 523 | M12 | 424 | 280 | 310 | 300 | 632 | 148 | 484 | 846 | 292 | 708 | 228 | 185 |
| | 80 | 1535 | 135 | 831 | 327 | 35 | 300 | 579 | 132 | 490 | 441 | 1045 | 507 | 1437 | 1002 | 435 | 269 | 299 | 228 | 447 | 360 | 523 | M12 | 424 | 280 | 310 | 300 | 683 | 148 | 535 | 875 | 313 | 708 | 228 | 185 |
| HR93A | 50 | 1540 | 135 | 835 | 327 | 35 | 300 | 550 | 100 | 495 | 460 | 1045 | 507 | 1160 | 725 | 435 | 304 | 344 | 228 | 450 | 360 | 523 | M12 | 424 | 280 | 310 | 300 | 532 | 148 | 384 | 624 | 190 | 708 | 228 | 185 |
| | 65 | 1540 | 135 | 835 | 327 | 35 | 300 | 564 | 117 | 495 | 460 | 1045 | 507 | 1406 | 971 | 435 | 304 | 344 | 228 | 447 | 360 | 523 | M12 | 424 | 280 | 310 | 300 | 632 | 148 | 484 | 846 | 292 | 708 | 228 | 185 |
| | 80 | 1540 | 135 | 835 | 327 | 35 | 300 | 579 | 132 | 495 | 460 | 1045 | 507 | 1437 | 1002 | 435 | 304 | 344 | 228 | 447 | 360 | 523 | M12 | 424 | 280 | 310 | 300 | 683 | 148 | 535 | 875 | 313 | 708 | 228 | 185 |
| | 100 | 1540 | 135 | 835 | 327 | 35 | 300 | 592 | 145 | 495 | 460 | 1045 | 507 | 1520 | 1085 | 435 | 304 | 344 | 228 | 447 | 360 | 523 | M12 | 424 | 280 | 310 | 300 | 790 | 148 | 642 | 942 | 353 | 708 | 228 | 185 |

*DN = gas valves size

NOTE: the overall dimensions are referred to burners provided with Siemens VGD valves.

B*: SPECIAL BLAST TUBE LENGTHS MUST BE AGREED WITH CIB UNIGAS

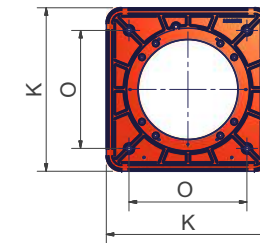
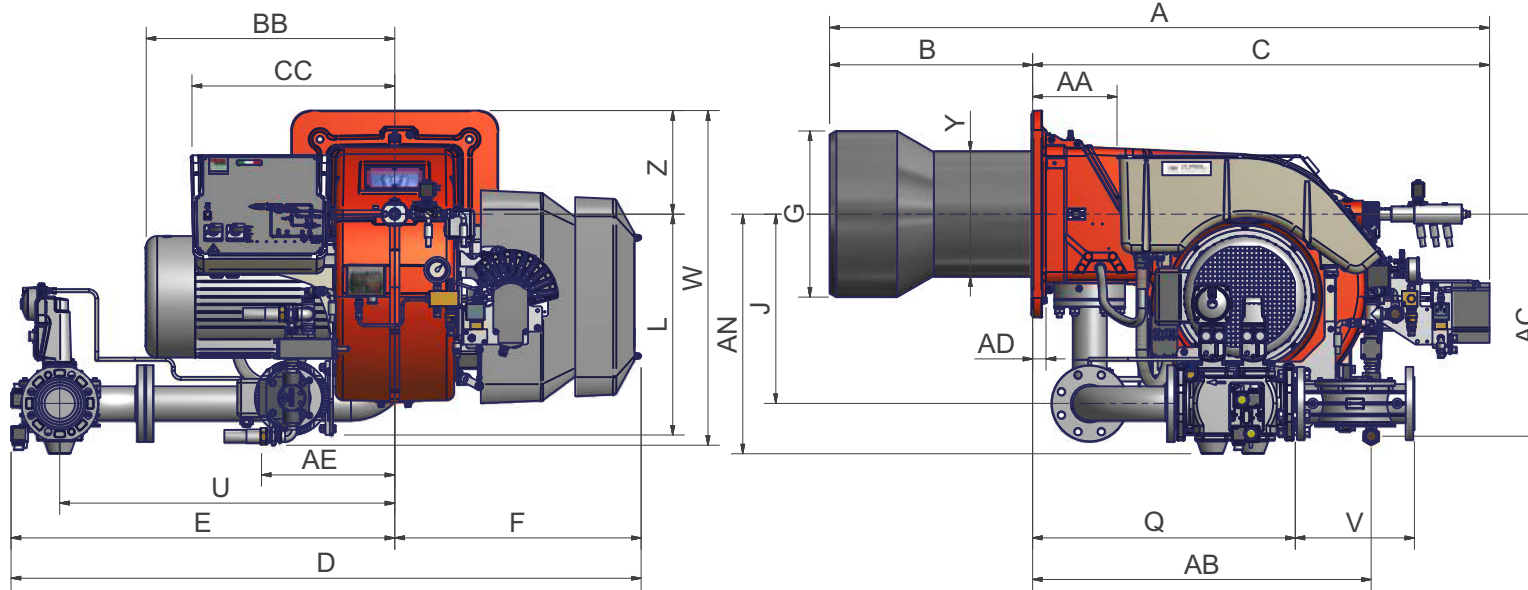

Burner flange

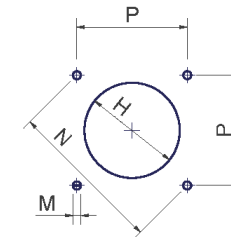

Boiler recommended drilling tem-

| | DN* | A | AA | AB | AC | AD | AE | AN | AP | B | BB | C | CC | D | E | F | G | H | J | K | L | M | N | O | P | Q | R | S | U | V | W | Y | Z |
|---------------|-----|------|-----|-----|-----|----|-----|-----|-----|-----|-----|------|-----|------|------|-----|-----|-----|-----|-----|-----|-----|-----|-----|-----|-----|-----|-----|-----|-----|-----|-----|-----|
| HR512A | 50 | 1723 | 220 | 924 | 364 | 35 | 326 | 595 | 100 | 530 | 517 | 1193 | 529 | 1590 | 946 | 644 | 340 | 380 | 494 | 540 | 560 | M14 | 552 | 390 | 390 | 763 | 149 | 614 | 845 | 190 | 830 | 307 | 270 |
| | 65 | 1723 | 220 | 924 | 364 | 35 | 326 | 611 | 117 | 530 | 517 | 1193 | 529 | 1613 | 969 | 644 | 340 | 380 | 494 | 540 | 560 | M14 | 552 | 390 | 390 | 636 | 149 | 487 | 845 | 292 | 830 | 307 | 270 |
| | 80 | 1723 | 220 | 924 | 364 | 35 | 326 | 626 | 132 | 530 | 517 | 1193 | 529 | 1646 | 1002 | 644 | 340 | 380 | 494 | 540 | 560 | M14 | 552 | 390 | 390 | 687 | 149 | 538 | 875 | 310 | 830 | 307 | 270 |
| | 100 | 1723 | 220 | 924 | 364 | 35 | 326 | 639 | 145 | 530 | 517 | 1193 | 529 | 1726 | 1082 | 644 | 340 | 380 | 494 | 540 | 560 | M14 | 552 | 390 | 390 | 791 | 149 | 642 | 942 | 353 | 830 | 307 | 270 |
| HR515A | 50 | 1723 | 220 | 928 | 371 | 35 | 333 | 595 | 100 | 530 | 517 | 1193 | 529 | 1590 | 946 | 644 | 380 | 420 | 494 | 540 | 560 | M14 | 552 | 390 | 390 | 763 | 149 | 614 | 845 | 190 | 830 | 310 | 270 |
| | 65 | 1723 | 220 | 928 | 371 | 35 | 333 | 611 | 117 | 530 | 517 | 1193 | 529 | 1613 | 969 | 644 | 380 | 420 | 494 | 540 | 560 | M14 | 552 | 390 | 390 | 636 | 149 | 487 | 845 | 292 | 830 | 310 | 270 |
| | 80 | 1723 | 220 | 928 | 371 | 35 | 333 | 626 | 132 | 530 | 517 | 1193 | 529 | 1646 | 1002 | 644 | 380 | 420 | 494 | 540 | 560 | M14 | 552 | 390 | 390 | 687 | 149 | 538 | 875 | 310 | 830 | 310 | 270 |
| | 100 | 1723 | 220 | 928 | 371 | 35 | 333 | 639 | 145 | 530 | 517 | 1193 | 529 | 1726 | 1082 | 644 | 380 | 420 | 494 | 540 | 560 | M14 | 552 | 390 | 390 | 791 | 149 | 642 | 942 | 353 | 830 | 310 | 270 |
| HR520A | 50 | 1723 | 220 | 928 | 371 | 35 | 333 | 595 | 100 | 530 | 517 | 1193 | 529 | 1590 | 946 | 644 | 400 | 440 | 494 | 540 | 560 | M14 | 552 | 390 | 390 | 763 | 149 | 614 | 845 | 190 | 830 | 328 | 270 |
| | 65 | 1723 | 220 | 928 | 371 | 35 | 333 | 611 | 117 | 530 | 517 | 1193 | 529 | 1613 | 969 | 644 | 400 | 440 | 494 | 540 | 560 | M14 | 552 | 390 | 390 | 636 | 149 | 487 | 845 | 292 | 830 | 328 | 270 |
| | 80 | 1723 | 220 | 928 | 371 | 35 | 333 | 626 | 132 | 530 | 517 | 1193 | 529 | 1646 | 1002 | 644 | 400 | 440 | 494 | 540 | 560 | M14 | 552 | 390 | 390 | 687 | 149 | 538 | 875 | 310 | 830 | 328 | 270 |
| | 100 | 1723 | 220 | 928 | 371 | 35 | 333 | 639 | 145 | 530 | 517 | 1193 | 529 | 1726 | 1082 | 644 | 400 | 440 | 494 | 540 | 560 | M14 | 552 | 390 | 390 | 791 | 149 | 642 | 942 | 353 | 830 | 328 | 270 |
| HR525A | 50 | 1723 | 220 | 884 | 580 | 35 | 350 | 595 | 100 | 530 | 650 | 1193 | 529 | 1590 | 946 | 644 | 434 | 484 | 494 | 540 | 604 | M14 | 552 | 390 | 390 | 763 | 149 | 614 | 845 | 190 | 874 | 328 | 270 |
| | 65 | 1723 | 220 | 884 | 580 | 35 | 350 | 611 | 117 | 530 | 650 | 1193 | 529 | 1613 | 969 | 644 | 434 | 484 | 494 | 540 | 604 | M14 | 552 | 390 | 390 | 636 | 149 | 487 | 845 | 292 | 874 | 328 | 270 |
| HR525A | 80 | 1723 | 220 | 884 | 580 | 35 | 350 | 626 | 132 | 530 | 650 | 1193 | 529 | 1646 | 1002 | 644 | 434 | 484 | 494 | 540 | 604 | M14 | 552 | 390 | 390 | 687 | 149 | 538 | 875 | 310 | 874 | 328 | 270 |
| | 100 | 1723 | 220 | 884 | 580 | 35 | 350 | 639 | 145 | 530 | 650 | 1193 | 529 | 1726 | 1082 | 644 | 434 | 484 | 494 | 540 | 604 | M14 | 552 | 390 | 390 | 791 | 149 | 642 | 942 | 353 | 874 | 328 | 270 |

*DN = gas valves size

NOTE: the overall dimensions are referred to burners provided with Siemens VGD valves.

Fig. 4 - 3I2MG-09 v1 Hydraulic diagram

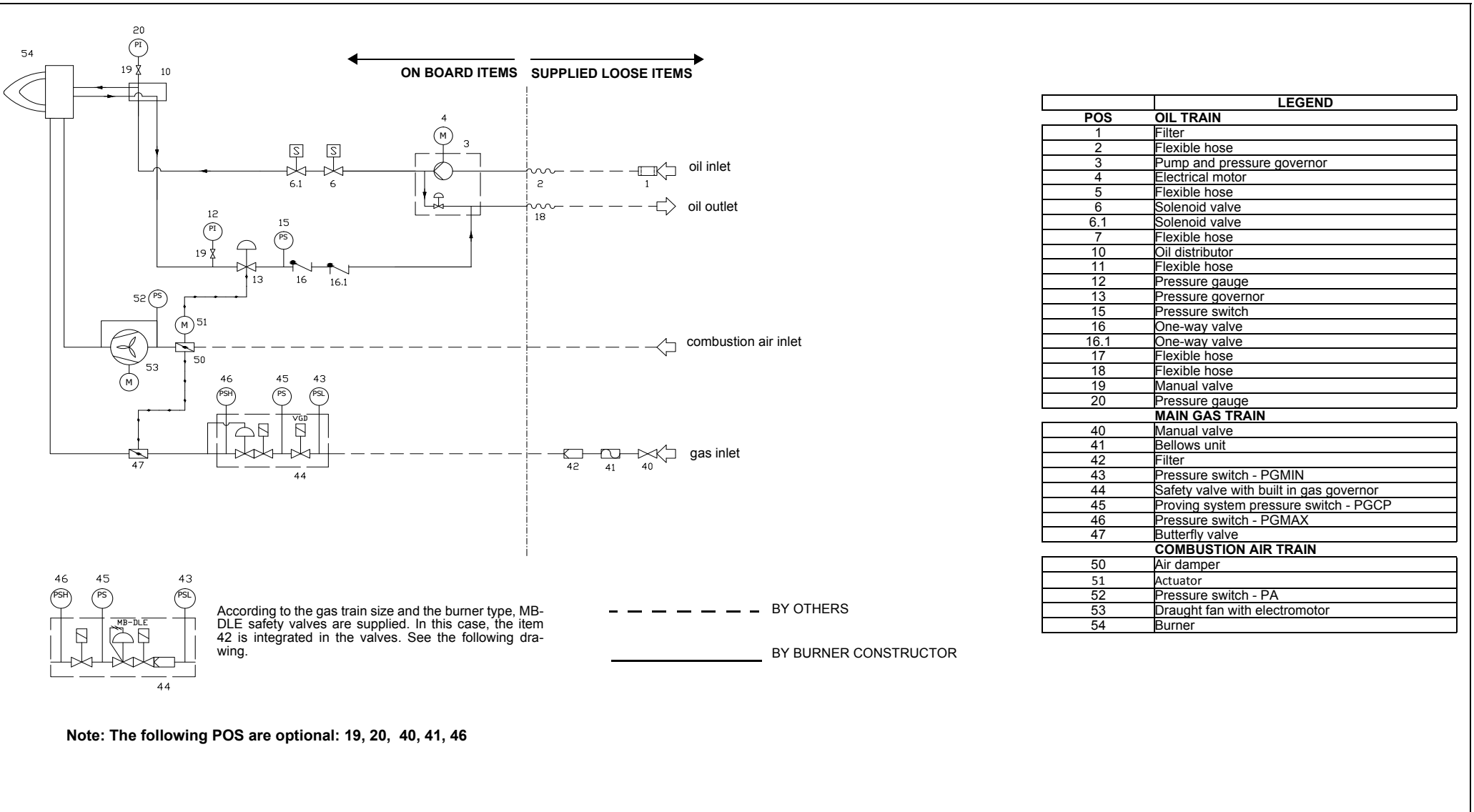
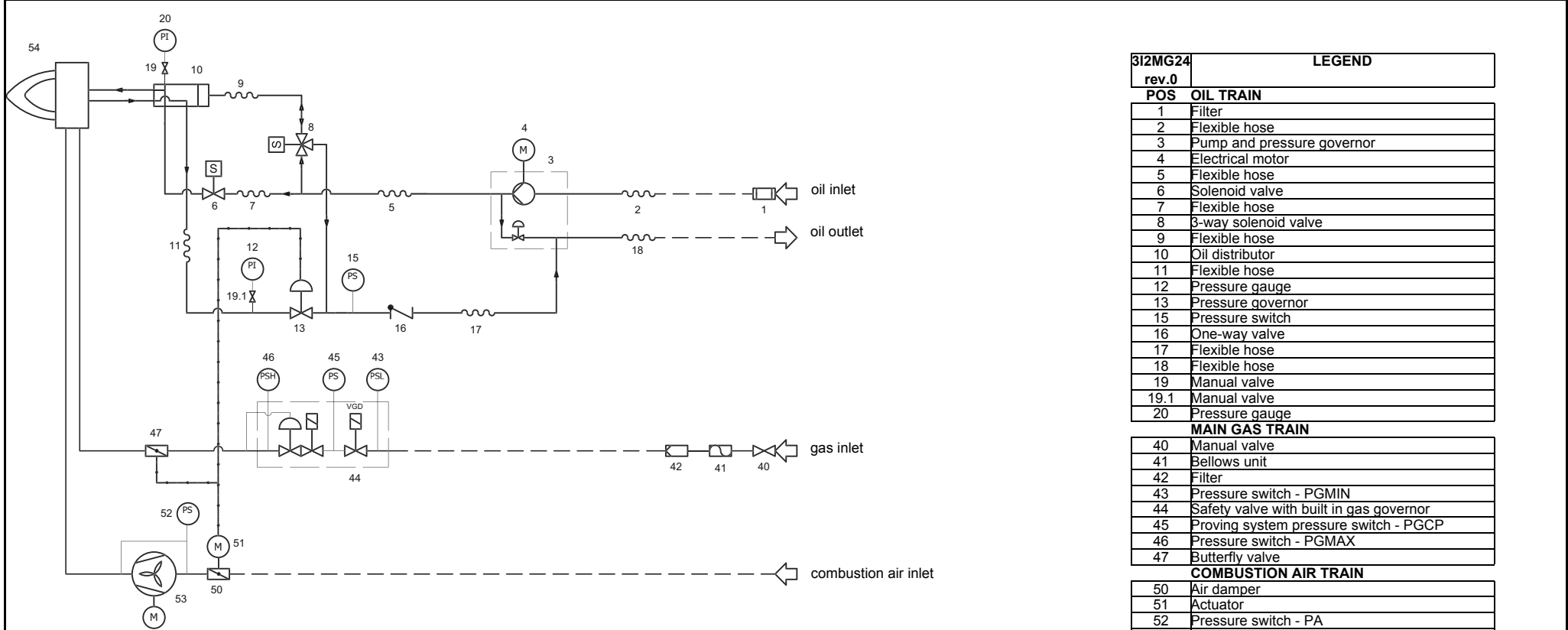

Fig. 5 - 3I2MG-24 v0 Hydraulic diagram



| 3I2MG24 | | LEGEND | |
|----------------------|---|--------|--|
| rev.0 | | | |
| POS | OIL TRAIN | | |
| 1 | Filter | | |
| 2 | Flexible hose | | |
| 3 | Pump and pressure governor | | |
| 4 | Electrical motor | | |
| 5 | Flexible hose | | |
| 6 | Solenoid valve | | |
| 7 | Flexible hose | | |
| 8 | 3-way solenoid valve | | |
| 9 | Flexible hose | | |
| 10 | Oil distributor | | |
| 11 | Flexible hose | | |
| 12 | Pressure gauge | | |
| 13 | Pressure governor | | |
| 15 | Pressure switch | | |
| 16 | One-way valve | | |
| 17 | Flexible hose | | |
| 18 | Flexible hose | | |
| 19 | Manual valve | | |
| 19.1 | Manual valve | | |
| 20 | Pressure gauge | | |
| MAIN GAS TRAIN | | | |
| 40 | Manual valve | | |
| 41 | Bellows unit | | |
| 42 | Filter | | |
| 43 | Pressure switch - PGMIN | | |
| 44 | Safety valve with built in gas governor | | |
| 45 | Proving system pressure switch - PGCP | | |
| 46 | Pressure switch - PGMAX | | |
| 47 | Butterfly valve | | |
| COMBUSTION AIR TRAIN | | | |
| 50 | Air damper | | |
| 51 | Actuator | | |
| 52 | Pressure switch - PA | | |
| 53 | Draught fan with electromotor | | |
| 54 | Burner | | |

Note: The following POS are optional: 19, 19.1, 20, 40, 41, 46
 Note: The following POS are included only on certain types of burner: 5,7, 9, 11,17

----- BY OTHERS
 _____ BY BURNER CONSTRUCTOR

How to read the burner "Performance curve"

To check if the burner is suitable for the boiler to which it must be installed, the following parameters are needed:

- furnace input, in kW or kcal/h ($\text{kW} = \text{kcal/h}/860$);
- backpressure (data are available on the boiler ID plate or in the user's manual).

Example:

Furnace input: 600kW

Backpressure: 4 mbar

In the "Performance curve" diagram, draw a vertical line matching the furnace input value and an horizontal line matching the backpressure value. The burner is suitable if the intersection point A is inside the performance curve.

Data are referred to standard conditions: atmospheric pressure at 1013 mbar, ambient temperature at 15° C.

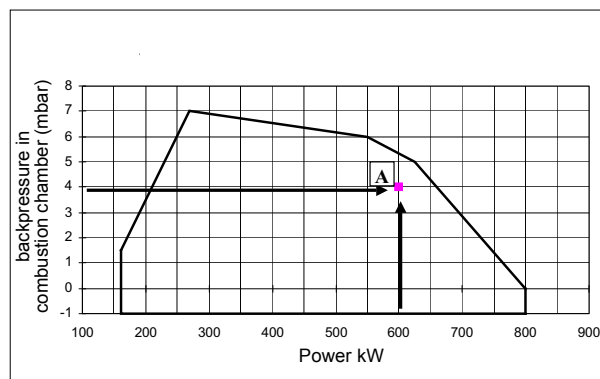

Checking the proper gas train size

To check the proper gas train size, it is necessary to the available gas pressure value upstream the burner's gas valve. Then subtract the backpressure. The result is called **pgas**. Draw a vertical line matching the furnace input value (600kW, in the example), quoted on the x-axis, as far as intercepting the network pressure curve, according to the installed gas train (DN65, in the example). From the interception point, draw an horizontal line as far as matching, on the y-axis, the value of pressure necessary to get the requested furnace input. This value must be lower or equal to the **pgas** value, calculated before.

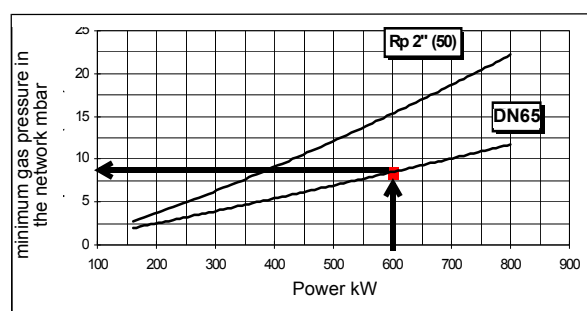

Performance Curves

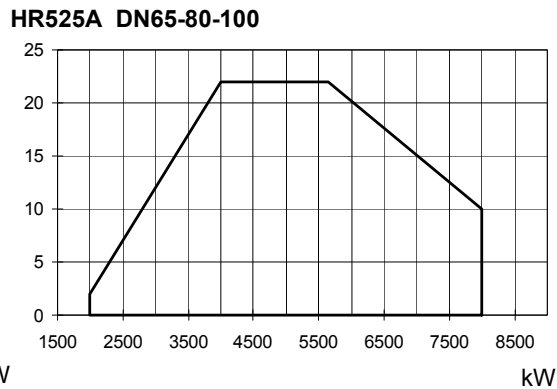
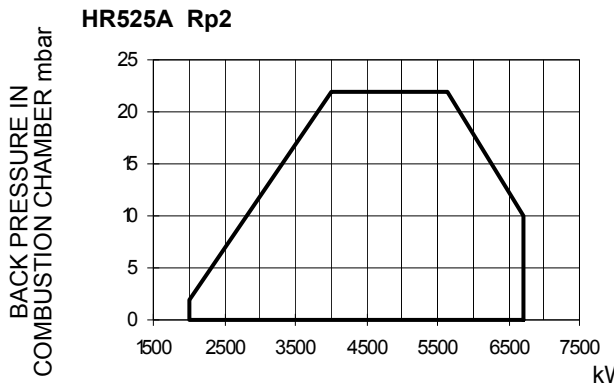
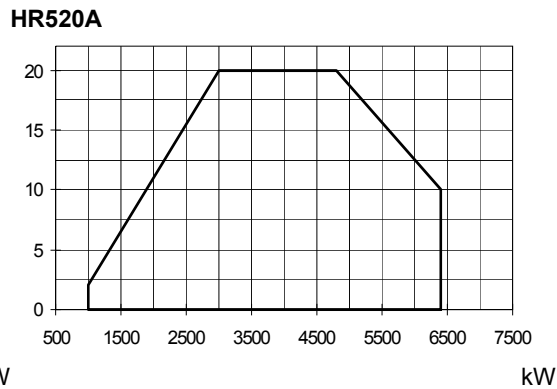
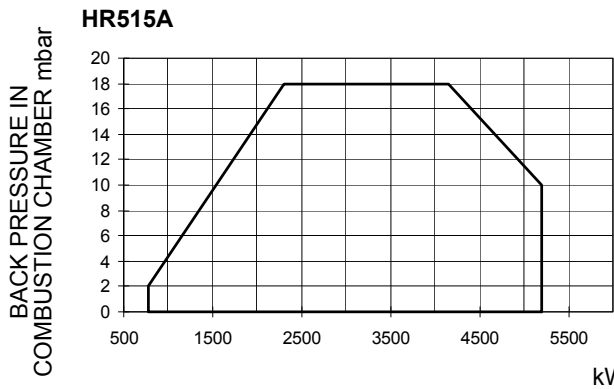
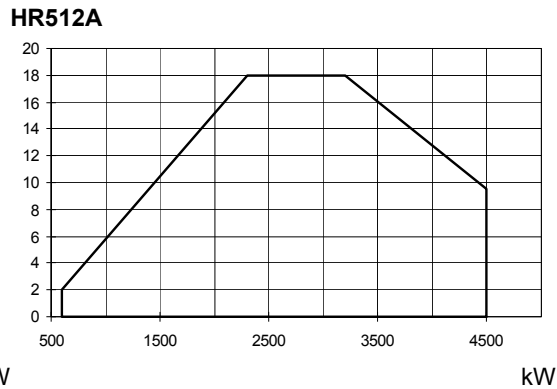
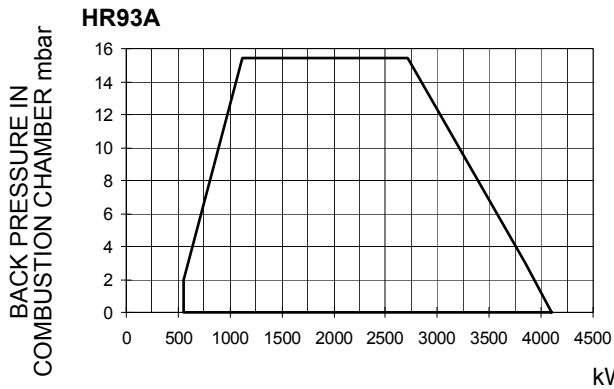
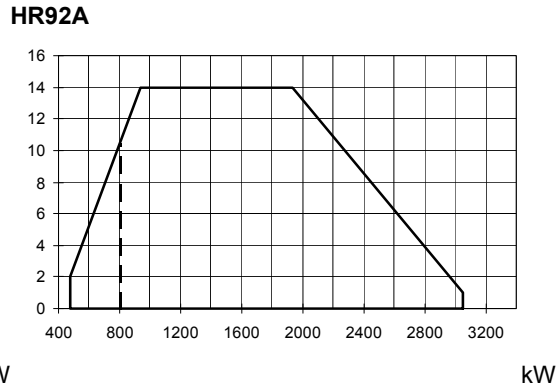

To get the input in kcal/h, multiply value in kW by 860.

Data are referred to standard conditions: atmospheric pressure at 1013mbar, ambient temperature at 15° C

NOTE: The performance curve is a diagram that represents the burner performance in the type approval phase or in the laboratory tests, but does not represent the regulation range of the machine. On this diagram the maximum output point is usually reached by adjusting the combustion head to its "MAX" position (see paragraph "Adjusting the combustion head"); the minimum output point is reached setting the combustion head to its "MIN" position. During the first ignition, the combustion head is set in order to find a compromise between the burner output and the generator specifications, that is why the minimum output may be different from the Performance curve minimum

Pressure in the Network / gas flow rate curves (natural gas)

HR91A MG..

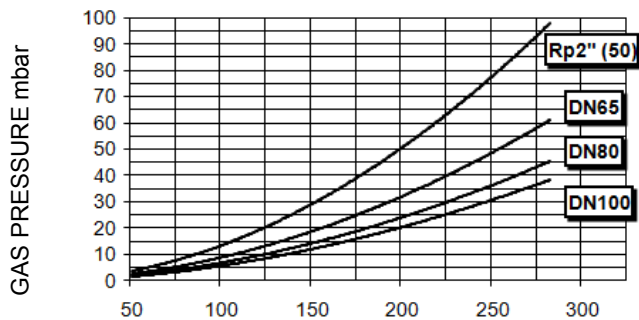

HR92A MG..

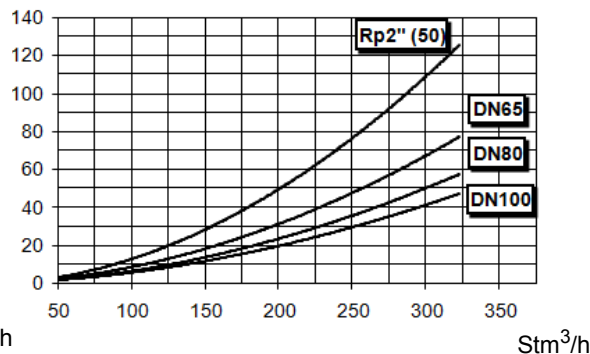

HR93A MG..

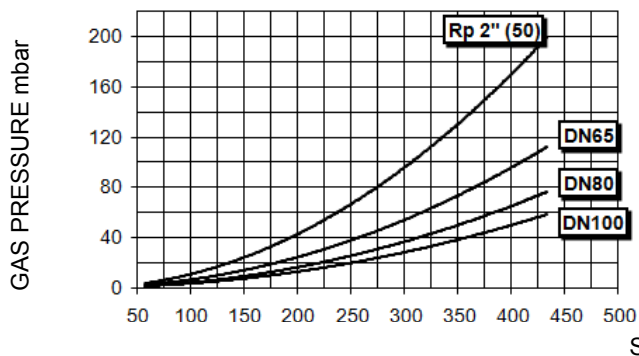

HR512A MG..

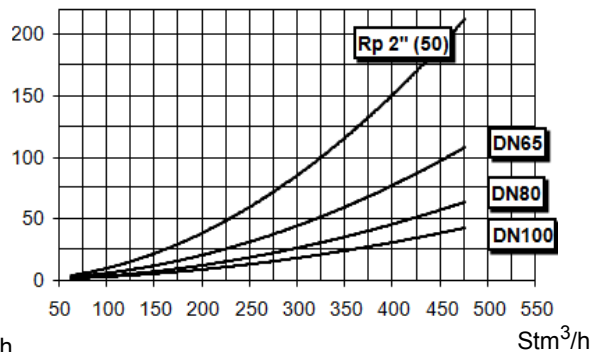

HR515A MG..

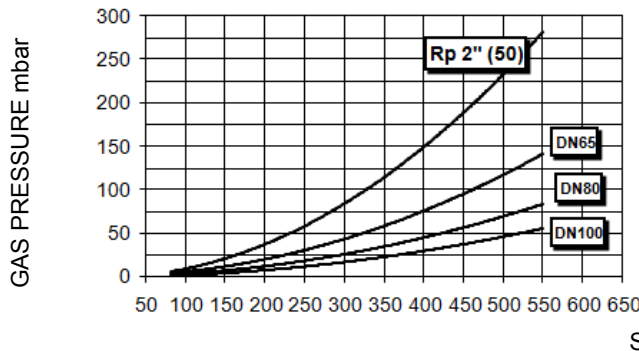

HR520A MG..

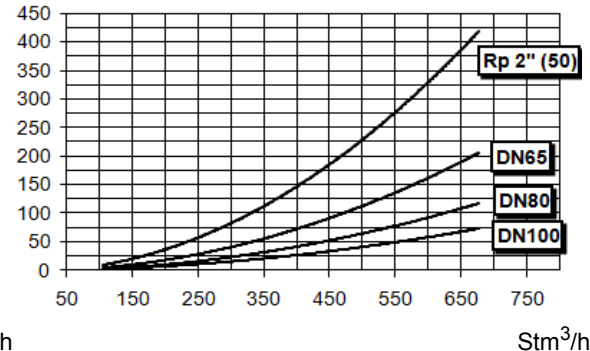

HR525A MG.. Rp2

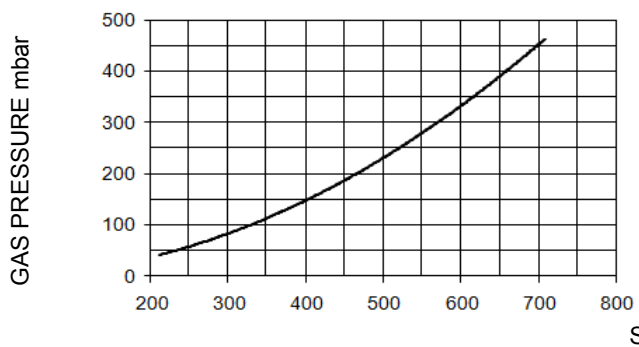

HR525A MG.. DN65-80-100

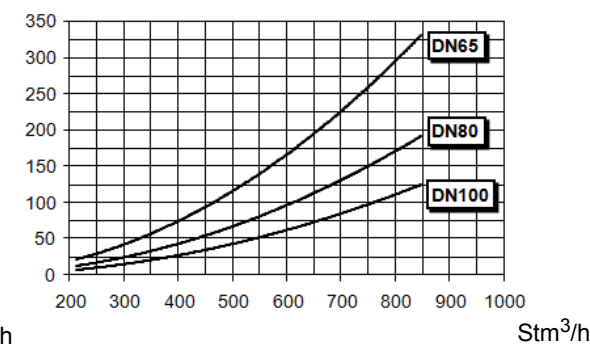

ATTENTION: the gas rate value is quoted on the x-axis, the related network pressure is quoted on the y-axis (pressure value in the combustion chamber is not included). To know the minimum pressure at the gas train inlet, necessary to get the requested gas rate, add the pressure value in the combustion chamber to the value read on the y-axis.

Pressure in the Network / gas flow rate curves (LPG)

HR91A LG..

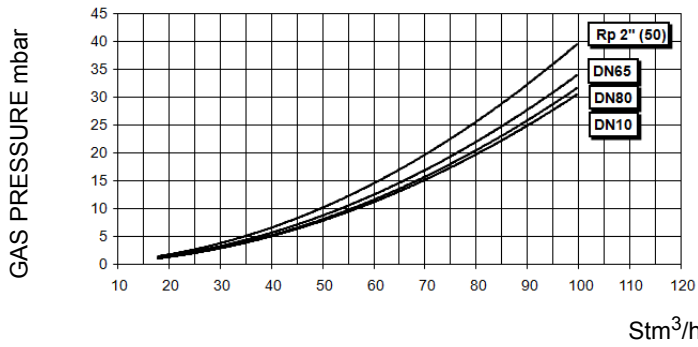

HR93A LG..

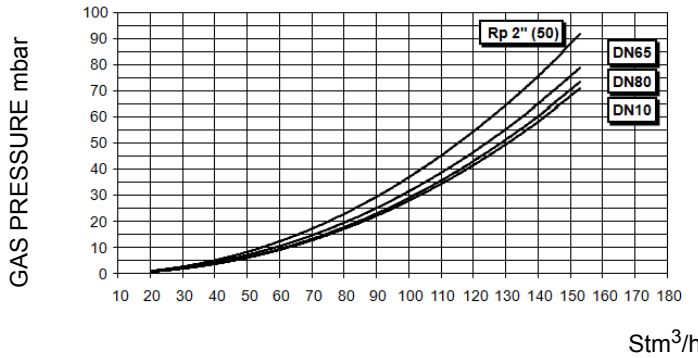

HR512A LG..

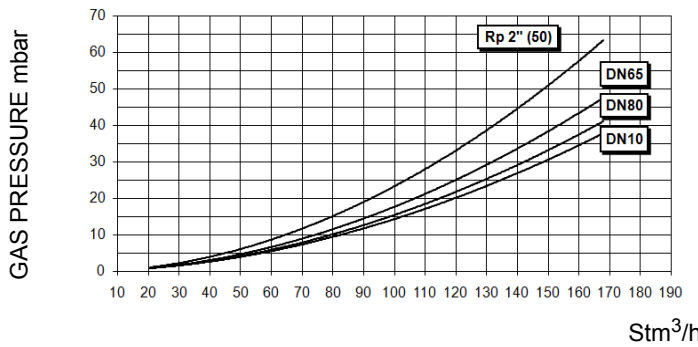

HR520A LG..

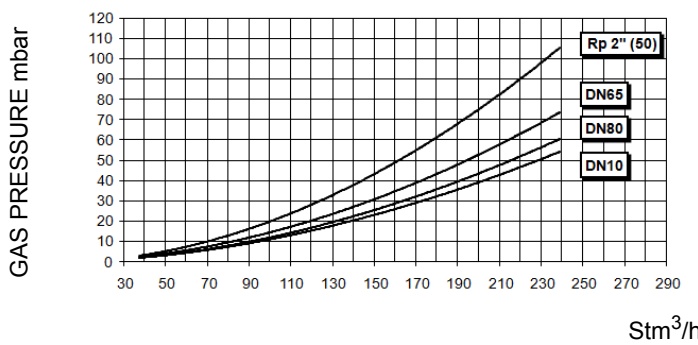

The values in the diagrams refer to **natural gas** with a calorific value of 8125 kcal/Stm³ (15°C, 1013 mbar) and a density of 0.714 kg/Stm³.



The values in the diagrams refer to **GPL** with a calorific value of 22300 kcal/Stm³ (15°C, 1013 mbar) and a density of 2.14 kg/Stm³. When the calorific value and the density change, the pressure values should be adjusted accordingly.

$$\Delta p_2 = \Delta p_1 * \left(\frac{Q_2}{Q_1}\right)^2 * \left(\frac{\rho_2}{\rho_1}\right)$$

Where:

- p* 1 natural gas pressure shown in diagram
- p* 2 real gas pressure
- Q* 1 natural gas flow rate shown in diagram
- Q* 2 real gas flow rate
- ρ* 1 natural gas density shown in diagram
- ρ* 2 real gas density



ATTENTION: the gas rate value is quoted on the x-axis, the related network pressure is quoted on the y-axis (pressure value in the combustion chamber is not included). To know the minimum pressure at the gas train inlet, necessary to get the requested gas rate, add the pressure value in the combustion chamber to the value read on the y-axis.

Combustion head gas pressure curves

Combustion head gas pressure depends on gas flow and combustion chamber backpressure. When backpressure is subtracted, it depends only on gas flow, provided combustion is properly adjusted, flue gases residual O₂ percentage complies with “Recommended combustion values” table and CO in the standard limits). During this stage, the combustion head, the gas butterfly valve and the actuator are at the maximum opening. Refer to Fig. 6, showing the correct way to measure the gas pressure, considering the values of pressure in combustion chamber, surveyed by means of the pressure gauge or taken from the boiler’s Technical specifications.

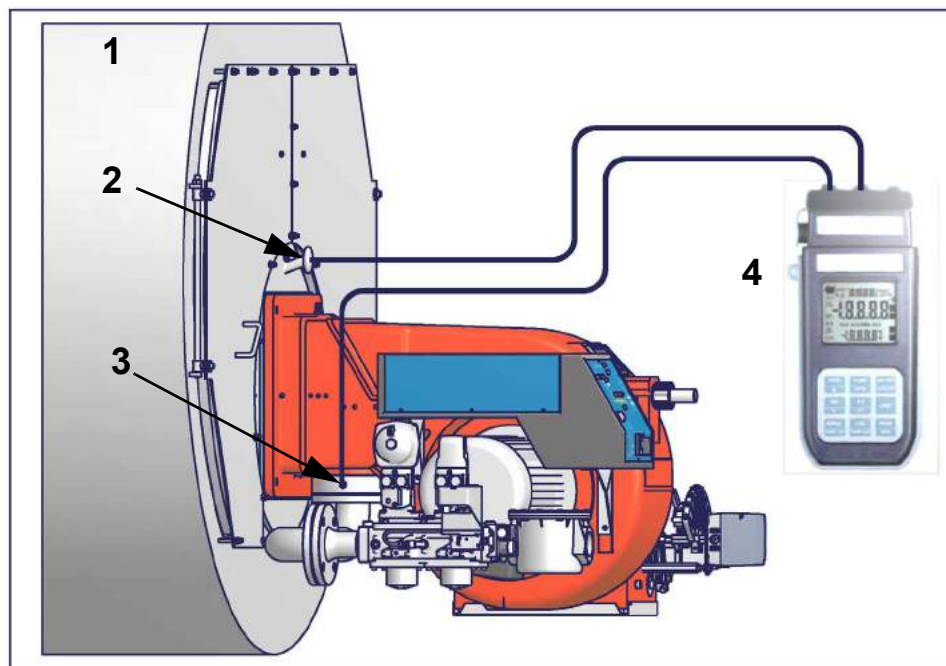

Fig. 6

Note: the figure is indicative only.

Key

- 1 Generator
- 2 Pressure outlet on the combustion chamber
- 3 Gas pressure outlet on the butterfly valve
- 4 Differential pressure gauge

Measuring gas pressure in the combustion head

In order to measure the pressure in the combustion head, insert the pressure gauge probes: one into the combustion chamber’s pressure outlet to get the pressure in the combustion chamber and the other one into the butterfly valve’s pressure outlet of the burner. On the basis of the measured differential pressure, it is possible to get the maximum flow rate: in the pressure - rate curves (showed on the next paragraph), it is easy to find out the burner’s output in Stm³/h (quoted on the x axis) from the pressure measured in the combustion head (quoted on the y axis). The data obtained must be considered when adjusting the gas flow rate.



ATTENTION: THE BURNED GAS RATE MUST BE READ AT THE GAS FLOW METER. WHEN IT IS NOT POSSIBLE, THE USER CAN REFERS TO THE PRESSURE-RATE CURVES AS GENERAL INFORMATION ONLY.

Pressure - rate in combustion head curves (natural gas)



Curves are referred to pressure = 0 mbar in the combustion chamber!

HR91A MG..

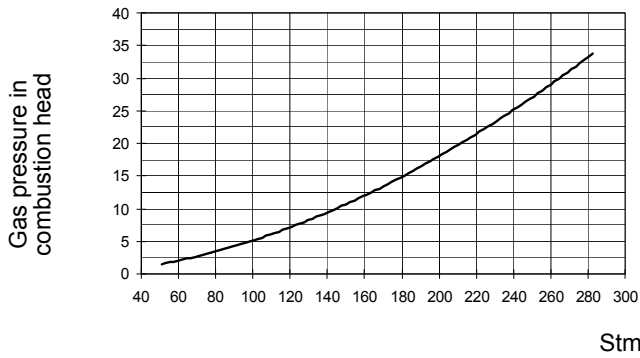

HR92A MG..

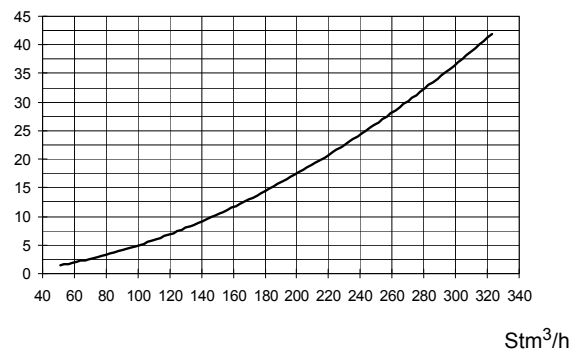

HR93A MG..

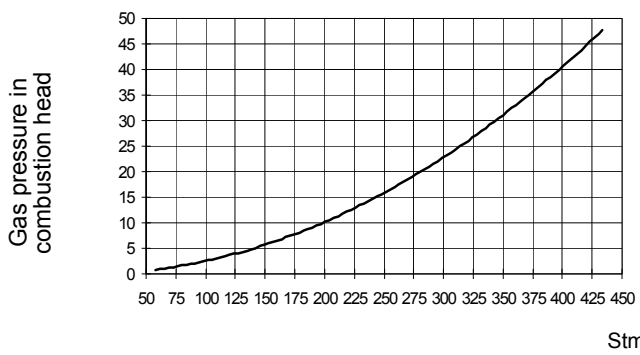

HR512A MG..

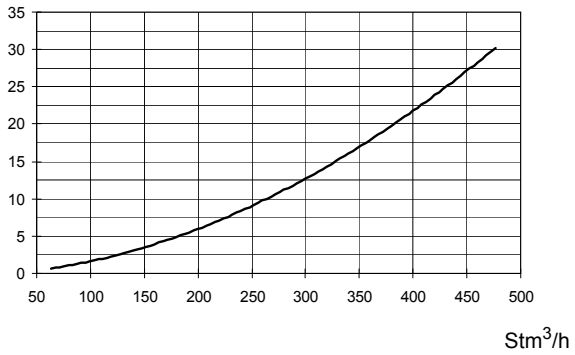

HR515A MG..

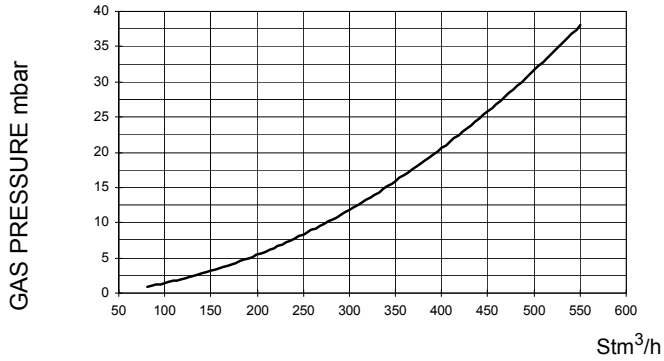

HR520A MG..

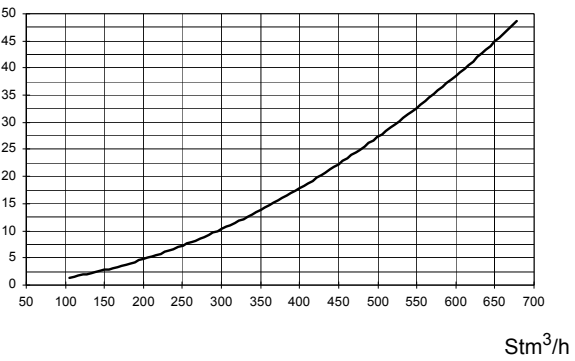

HR525A MG.. Rp2

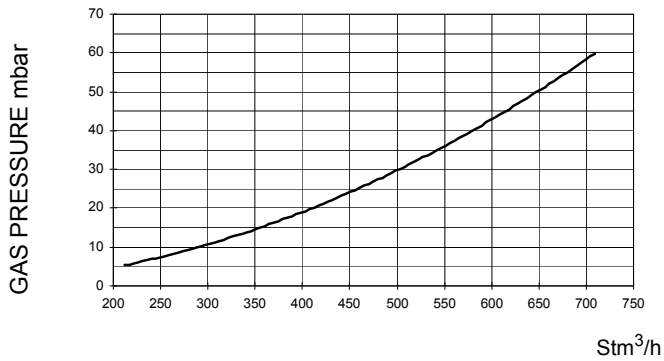

HR525A MG.. DN65-80-100

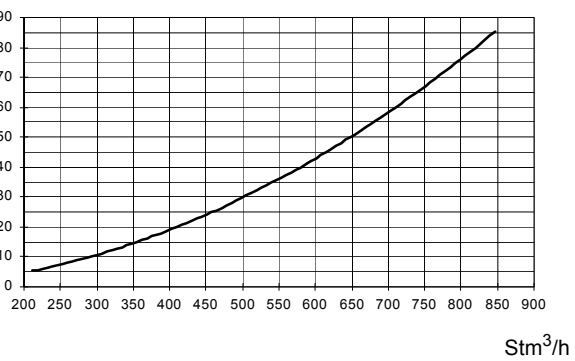

Pressure - rate in combustion head curves (LPG)



Curves are referred to pressure = 0mbar in the combustion chamber!

HR91A LG..

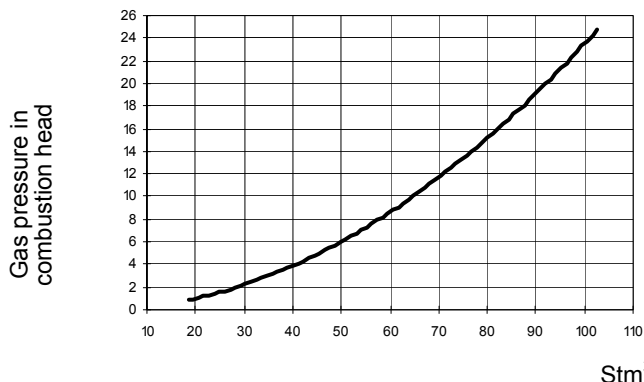

HR93A LG..

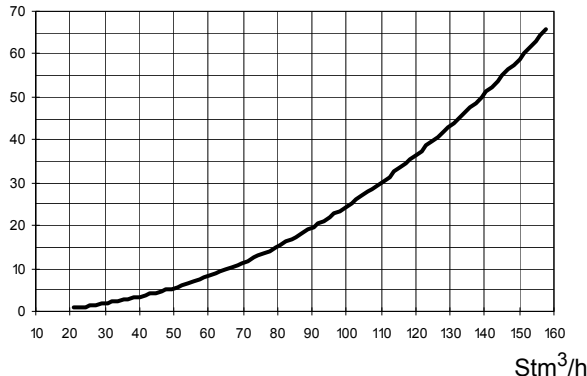

HR512A LG..

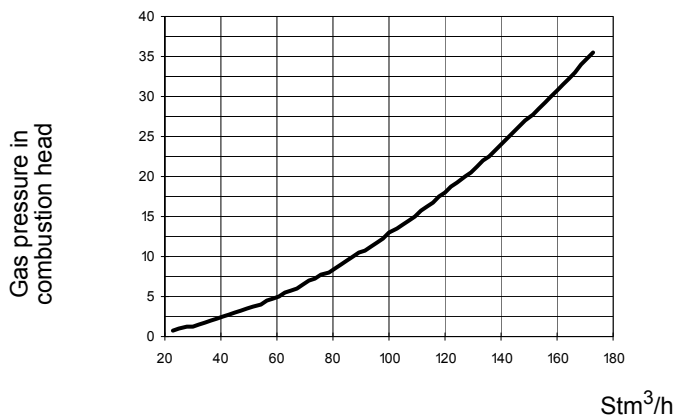

HR520A LG..

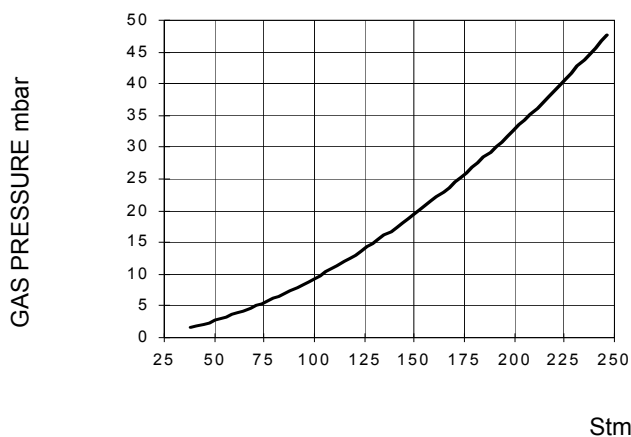

The values in the diagrams refer to **natural gas** with a calorific value of 8125 kcal/Stm³ (15°C, 1013 mbar) and a density of 0.714 kg/Stm³.



The values in the diagrams refer to **GPL** with a calorific value of 22300 kcal/Stm³ (15°C, 1013 mbar) and a density of 2.14 kg/Stm³. When the calorific value and the density change, the pressure values should be adjusted accordingly.

$$\Delta p_2 = \Delta p_1 * \left(\frac{Q_2}{Q_1}\right)^2 * \left(\frac{\rho_2}{\rho_1}\right)$$

Where:

- p 1 natural gas pressure shown in diagram
- p 2 real gas pressure
- Q 1 natural gas flow rate shown in diagram
- Q 2 real gas flow rate
- ρ 1 natural gas density shown in diagram
- ρ 2 real gas density

MOUNTING AND CONNECTING THE BURNER

Transport and storage



ATTENTION! The equipment must be installed in compliance with the regulations in force, following the manufacturer's instructions, by qualified personnel. All handling operations must be carried out with appropriate resources and qualified personnel



ATTENTION: Use intact and correctly dimensioned hoisting equipment, conforms to the local regulations and health and safety regulations. Do not stand under lifted loads.

If the product must be stored, avoid humid and corrosive places. Observe the temperatures stated in the burner data table at the beginning of this manual.

Packing

The burners are despatched in wooden crates whose dimensions are:

- 9xA series HLG-E 210/240/350 AS: 1666mm x 1066mm x 1130mm (L x P x H)
- 5xxA series : 1886mm x 1456mm x 1120mm (L x P x H)

Packing cases of this type are affected by humidity and are not suitable for stacking.

The following are placed in each packing case:

- burner with detached gas train;
- gasket or ceramic fibre plait (according to burner type) to be inserted between the burner and the boiler;
- envelope containing this manual and other documents.
- oil flexible hoses;

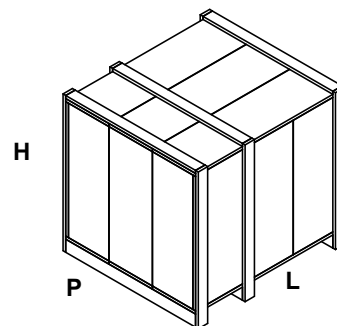

To get rid of the burner's packing, follow the procedures laid down by current laws on disposal of materials.

Handling the burner



WARNING! The handling operations must be carried out by specialised and trained personnel. If these operations are not carried out correctly, the residual risk for the burner to overturn and fall down still persists. To move the burner, use means suitable to support its weight (see paragraph "Technical specifications").

The unpacked burner must be lifted and moved only by means of a fork lift truck.

The burner is mounted on a stirrup provided for handling the burner by means of a fork lift truck: the forks must be inserted into the A and B ways. Remove the stirrup only once the burner is installed to the boiler.

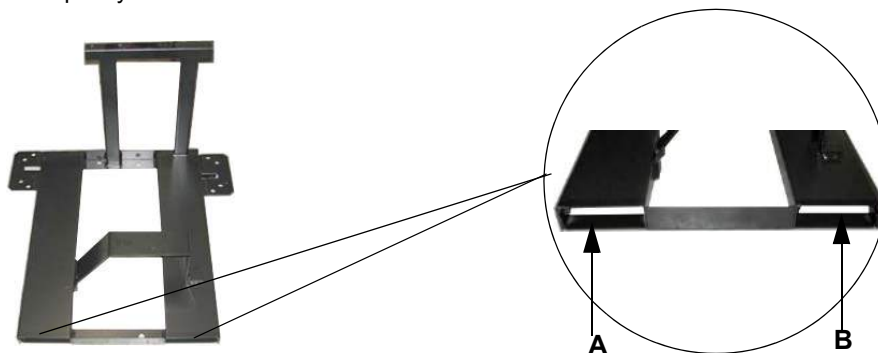

Fitting the burner to the boiler

To install the burner into the boiler, proceed as follows:

- 1 make a hole on the closing door of the combustion chamber as described on paragraph "Overall dimensions")
- 2 place the burner to the boiler: lift it up and handle it according to the procedure described on paragraph "Handling the burner";
- 3 place the 4 stud bolts (5) on boiler's door, according to the burner drilling template described on paragraph "Overall dimensions";
- 4 fasten the 4 stud bolts;
- 5 place the gasket on the burner flange;
- 6 install the burner into the boiler;
- 7 fix the burner to the stud bolts, by means of the fixing nuts, according to the next picture.
- 8 After fitting the burner to the boiler, ensure that the gap between the blast tube and the refractory lining is sealed with appropriate insulating material (ceramic fibre cord or refractory cement).

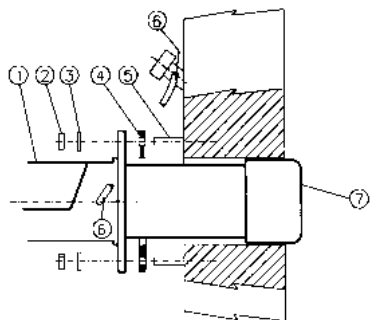

Keys

- 1 Burner
- 2 Fixing nut
- 3 Washer
- 4 Sealing gasket
- 5 Stud bolt
- 7 Blast tube

Matching the burner to the boiler

The burners described in this manual have been tested with combustion chambers that comply with EN676 regulation and whose dimensions are described in the diagram. In case the burner must be coupled with boilers with a combustion chamber smaller in diameter or shorter than those described in the diagram, please contact the supplier, to verify that a correct matching is possible, with respect of the application involved. To correctly match the burner to the boiler verify the type of the blast tube. Verify the necessary input and the pressure in combustion chamber are included in the burner performance curve; otherwise the choice of the burner must be revised consulting the burner manufacturer. To choose the blast tube length follow the instructions of the boiler manufacturer. In absence of these consider the following:

- Cast-iron boilers, three pass flue boilers (with the first pass in the rear part): the blast tube must protrude no more than **Dist** = 100 mm into the combustion chamber. (please see the picture below)
- Pressurised boilers with flame reversal: in this case the blast tube must penetrate **Dm** 50 ÷ 100 mm into combustion chamber in respect to the tube bundle plate.(please see the picture below)

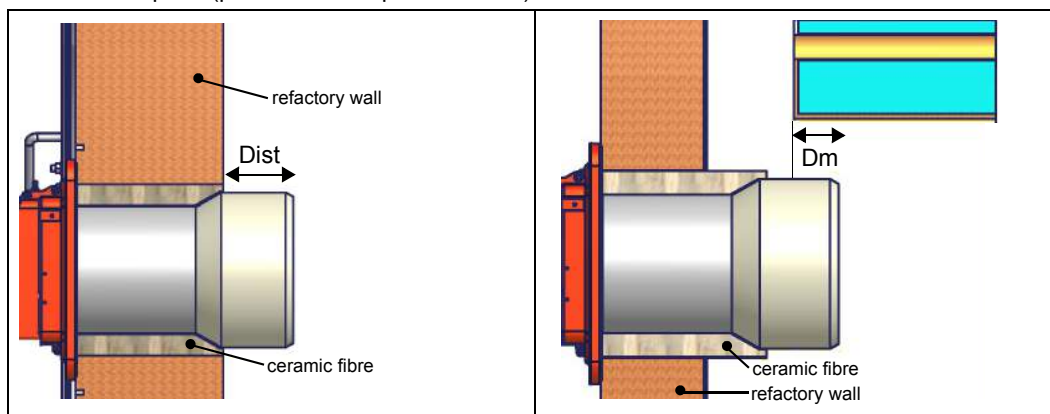

WARNING! Carefully seal the free space between blast tube and the refractory lining with ceramic fibre rope or other suitable means.

The length of the blast tubes does not always allow this requirement to be met, and thus it may be necessary to use a suitably-sized spacer to move the burner backwards or to design a blast tube that suits the utilisation (please, contact the manufacturer).

GAS TRAIN CONNECTIONS

The diagrams show the components of the gas train included in the delivery and which must be fitted by the installer. The diagrams are in compliance with the current laws.

Procedure to install the double gas valve unit:

- two (2) gas flanges are required; they may be threaded or not depending on size;
- first step: install the flanges to prevent the entry of foreign bodies in the gas line;
- on the gas pipe, clean the already assembled parts and then install the valve unit;
- check gas flow direction: it must follow the arrow on the valve body;
- VGD20: make sure the O-rings are correctly positioned between the flanges and the valve;
- VGD40 and MBE: make sure the gaskets are correctly positioned between the flanges;
- fasten all the components with screws, according to the following diagrams;
- make sure bolts on the flanges are properly tightened;



WARNING: before executing the connections to the gas pipe network, be sure that the manual cutoff valves are closed.



ATTENTION: it is recommended to mount filter and gas valves to avoid that extraneous material drops inside the valves, during maintenance and cleaning operation of the filters (both the filters outside the valves group and the ones built-in the gas valves).



ATTENTION: once the gas train is mounted according to the diagram on Fig. 1, the gas proving test must be performed, according to the procedure set by the laws in force.

и MBEGas train with valves group VGD and MBE with built-in gas pressure governor + gas leakage pressure switch (PGCP)

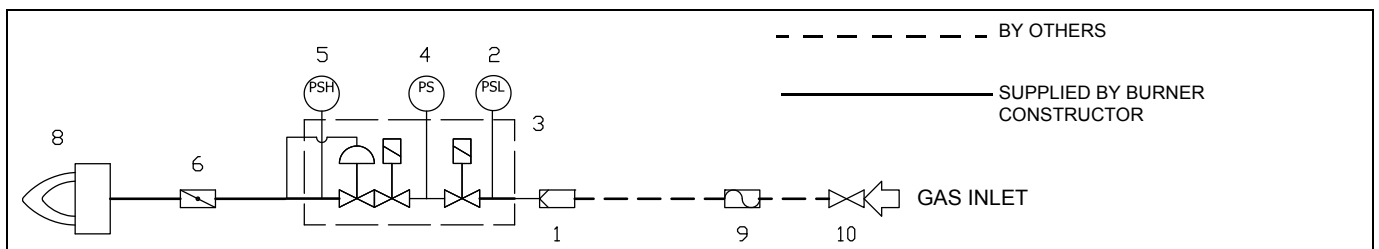

Key

| | | | |
|---|---|----|-------------------------|
| 1 | Filter | 6 | Butterfly valve |
| 2 | Pressure switch - PGMIN | 8 | Main burner |
| 3 | Safety valve with built in gas governor | 9 | Bellows unit(*optional) |
| 4 | Proving system pressure switch - PGCP | 10 | Manual valve(*optional) |
| 5 | Pressure switch PGMAX:included MBE, for VGD e MB-DLE Optional | | |

MultiBloc MBE

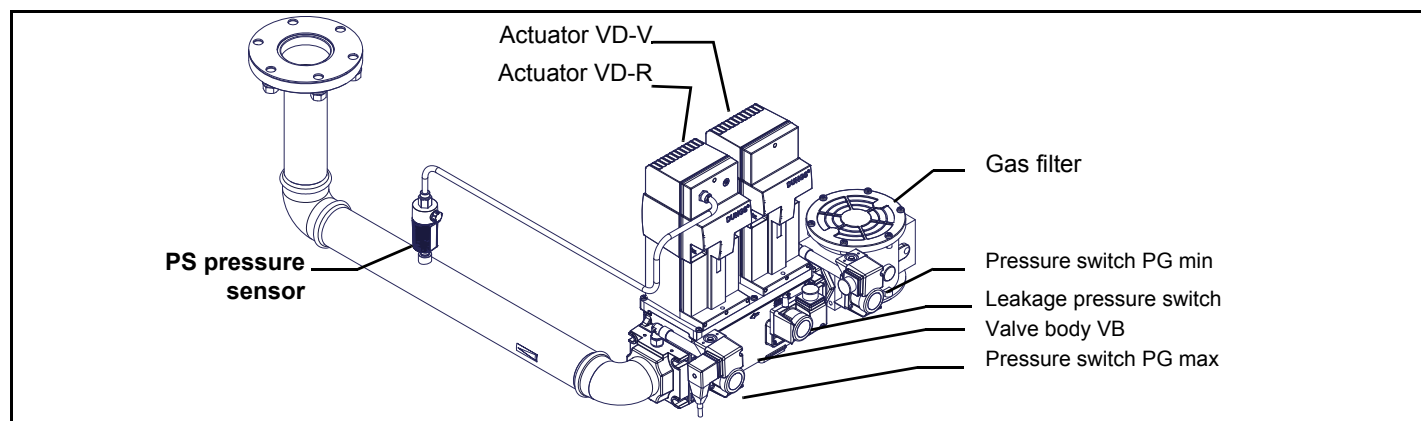

Fig. 7 Example of gas train MBE

To mount the gas train, proceed as follows:

1-a) in case of threaded joints: use proper seals according to the gas used;

1-b) in case of flanged joints: place a gasket (no. 1A..1E - Fig. 4) between the elements;

2) fasten all the items by means of screws, according to the diagrams showed, observing the mounting direction for each item;

NOTE: the bellows unit, the manual cutoff valve and the gaskets are not part of the standard supply.



ATTENTION: once the gas train is mounted according to the diagram on Fig. 4, the gas proving test must be performed, according to the procedure set by the laws in force.



ATTENTION: it is recommended to mount filter and gas valves to avoid that extraneous material drops inside the valves, during maintenance and cleaning operation of the filters (both the filters outside the valves group and the ones built-in the gas valves).



WARNING: Slowly open the fuel cock to avoid breaking the pressure regulator.

Threaded train with MultiBloc MBE - Mounting

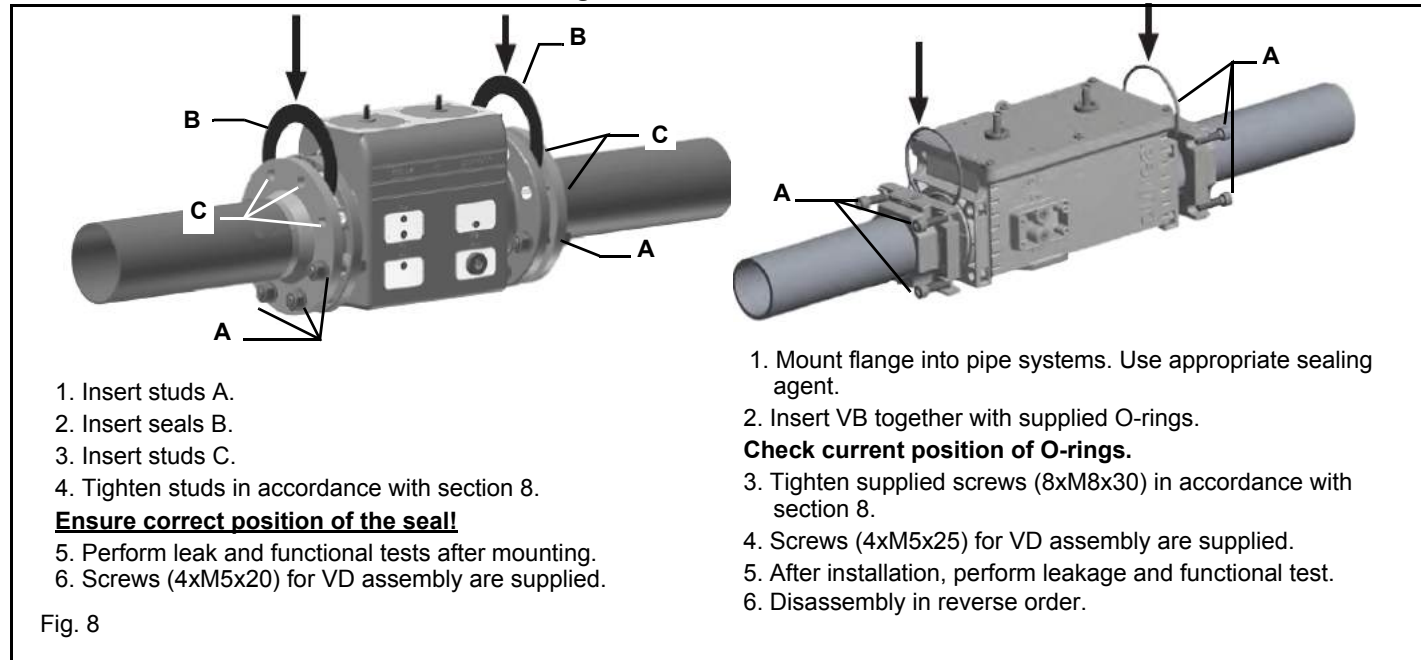

Fig. 8

Mounting position MBE / VB / VD

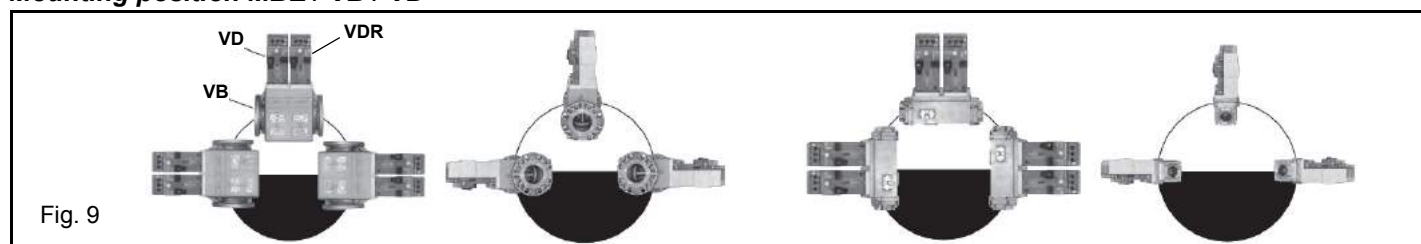

Fig. 9

Mounting VD-R & PS-...

Fig. 10

Siemens VGD20.. e VGD40..

Siemens VGD20.. and VGD40.. gas valves - with SKP2.. (pressure governor)

- Connect the reference gas pipe (**TP** in figure; 8mm-external size pipe supplied loose), to the gas pressure nipples placed on the gas pipe, downstream the gas valves: gas pressure must be measured at a distance that must be at least 5 times the pipe size.
- Leave the blowhole free (**SA** in figure). Should the spring fitted not permit satisfactory regulation, ask one of our service centres for a suitable replacement.

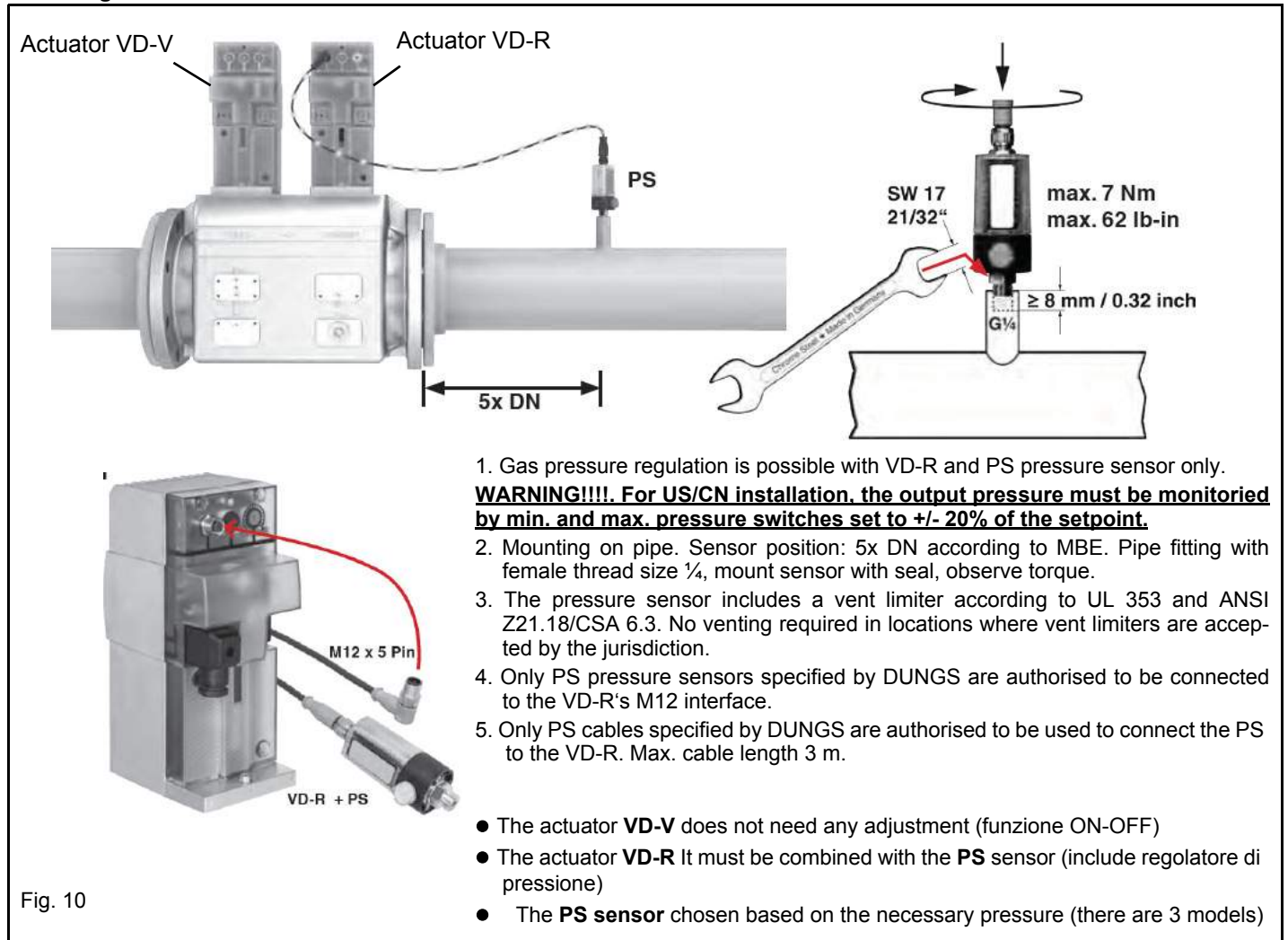

Caution: the SKP2 diaphragm **D** must be vertical (see Fig. 11).



WARNING: removing the four screws **BS** causes the device to be unserviceable!

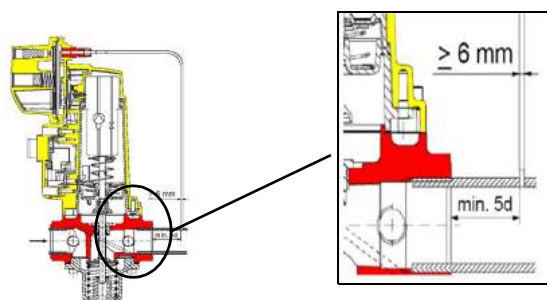
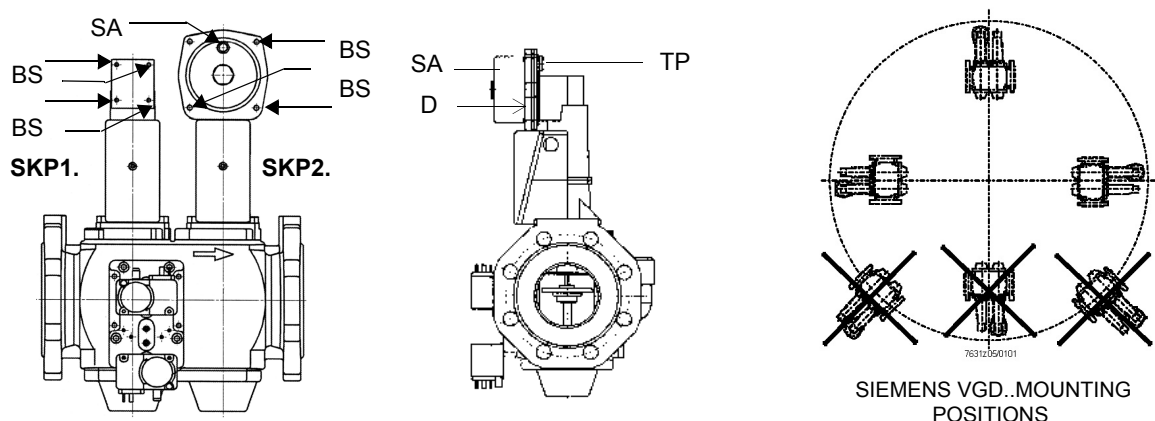

Siemens VGD valves with SKP actuator:

The pressure adjusting range, upstream the gas valves group, changes according to the spring provided with the valve group.

Fig. 11

Gas valve version with SKP2 (built-in pressure stabilizer)



To replace the spring supplied with the valve group, proceed as follows:

- Remove the cap (T)
 - Unscrew the adjusting screw (VR) with a screwdriver
 - Replace the spring
- Stick the adhesive label for spring identification on the type plate.

| | | | |
|--------------------------|---------|----------|-----------|
| Performance range (mbar) | 0 - 22 | 15 - 120 | 100 - 250 |
| Spring colour | neutral | yellow | red |

Gas Filter (if provided)

The gas filters remove the dust particles that are present in the gas, and prevent the elements at risk (e.g.: burner valves, counters and regulators) from becoming rapidly blocked. The filter is normally installed upstream from all the control and on-off devices.



ATTENTION: it is recommended to install the filter with gas flow parallel to the floor in order to prevent dust fall on the safety valve during maintenance operation.

Once the train is installed, connect the gas valves group and pressure switches plugs.

Integrated proving system (burners equipped with LME7x, LMV, LDU)

This paragraph describes the integrated proving system operation sequence:

- At the beginning both the valves (EV1 and EV2) must be closed.
- Test space evacuating: EV2 valve (burner side) opens and keep this position for a preset time (td4), in order to bring the test space to ambient pressure. Test atmospheric pressure: EV2 closes and keep this position for a preset time (test time td1). The pressure switch PGCP has not to detect a rise of pressure.
- Test space filling: EV1 opens and keep this position for a preset time (td3), in order to fill the test space.
- Test gas pressure: EV1 closes and keep this position for a preset time (td2). The pressure switch PGCP has not to detect a pressure drop down.

If all of the test phases are passed the proving system test is successful, if not a burner lockout happens.

On LMV5x and LMV2x/3x and LME73 (except LME73.831BC), the valve proving can be parameterized to take place on startup, shutdown, or both.

On LME73.831BC the valve proving is parameterized to take place on startup only.

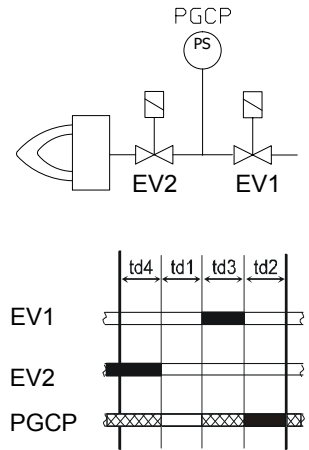

OIL TRAIN CONNECTIONS

Hydraulic diagrams for light oil supplying circuits

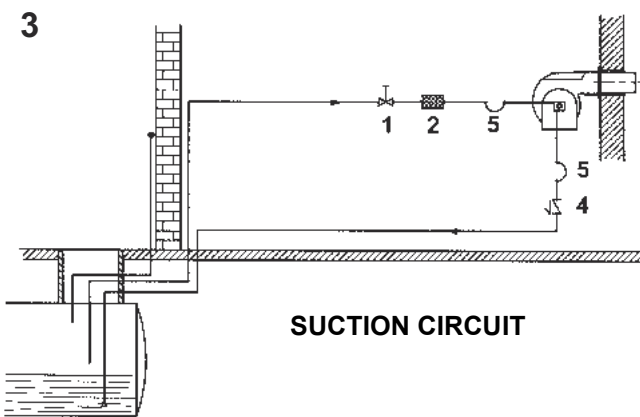
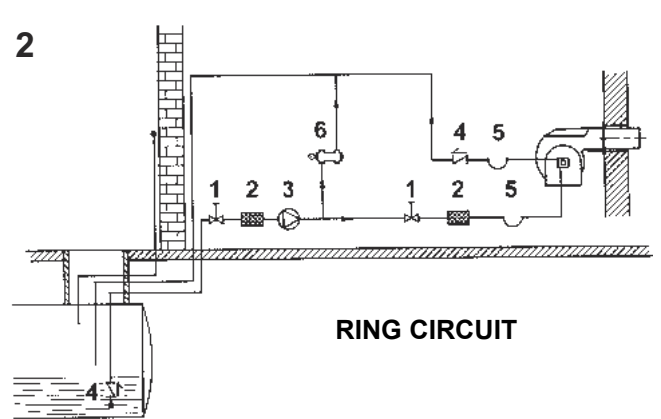
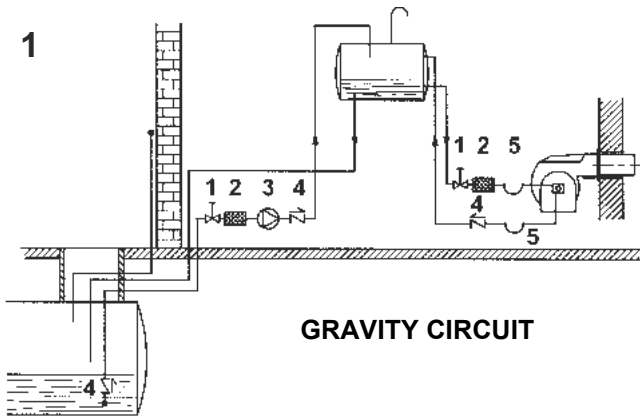

Key

- 1 Manual valve
- 2 Light oil filter
- 3 Light oil feeding pump
- 4 One way valve
- 5 Flexible hoses
- 6 Relief valve

NOTE: in plants where gravity or ring feed systems are provided, install an automatic interception device.

Installation diagram of light oil pipes



please read carefully the “warnings” chapter at the beginning of this manual.

Fig. 9 - Double-pipe system

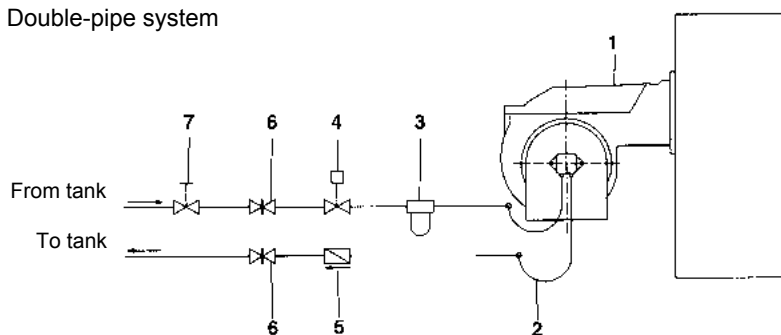

The burner is supplied with filter and flexible hoses, all the parts upstream the filter and downstream the return flexible hose, must be installed by the customer. As far as the hoses connection, see the related paragraph.

Key

- 1 Burner
- 2 Flexible hoses (fitted)
- 3 Light oil filter (fitted)
- 4 Automatic interceptor (*)
- 5 One-way valve (*)
- 6 Gate valve
- 7 Quick-closing gate-valve (outside the tank or boiler rooms)

(*) Only for installations with gravity, siphon or forced circulation feed systems. If the device installed is a solenoid valve, a timer must be installed to delay the valve closing. The direct connection of the device without a timer may cause pump breaks.

Depending on the installed pump, it is possible to design the plant for single or double pipe feeding line

Single-pipe system: a single pipe drives the oil from the tank to the pump's inlet. Then, from the pump, the pressurised oil is driven to the nozzle: a part comes out from the nozzle while the other part goes back to the pump. In this system, the by-pass plug, if provided, must be removed and the optional return port, on the pump's body, must be sealed by steel plug and washer.

Double-pipe system: as for the single pipe system, a pipe that connects the tank to the pump's inlet is used besides another pipe that connects the pump's return port to the tank, as well. The excess of oil goes back to the tank: this installation can be considered self-bleeding. If provided, the inside by-pass plug must be installed to avoid air and fuel passing through the pump.

Burners come out from the factory provided for double-pipe systems. They can be suited for single-pipe system (recommended in the case of gravity feed) as described before. To change from a 1-pipe system to a 2-pipe-system, insert the by-pass plug **G** (as for ccw-rotation- referring to the pump shaft).

Caution: Changing the direction of rotation, all connections on top and side are reversed. **HP UHE series pumps:** a kit (Art.-Nr.: 0841211) is required for the transition from 2-pipe to 1-pipe system

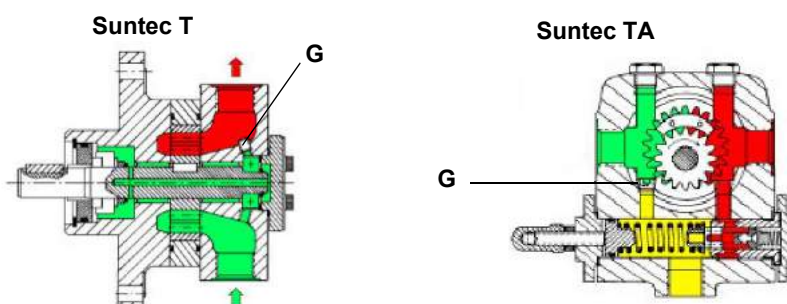

About the use of fuel pumps

- Do not use fuel with additives to avoid the possible formation over time of compounds which may deposit between the gear teeth, thus obstructing them.
- After filling the tank, wait before starting the burner. This will give any suspended impurities time to deposit on the bottom of the tank, thus avoiding the possibility that they might be sucked into the pump.
- On initial commissioning a "dry" operation is foreseen for a considerable length of time (for example, when there is a long suction line to bleed). To avoid damages inject some lubrication oil into the vacuum inlet.
- Care must be taken when installing the pump not to force the pump shaft along its axis or laterally to avoid excessive wear on the joint, noise and overloading the gears.
- Pipes should not contain air pockets. Rapid attachment joint should therefore be avoided and threaded or mechanical seal junctions preferred. Junction threads, elbow joints and couplings should be sealed with removable seal component. The number of junctions should be kept to a minimum as they are a possible source of leakage.
- Do not use PTFE tape on the suction and return line pipes to avoid the possibility that particles enter circulation. These could deposit on the pump filter or the nozzle, reducing efficiency. Always use O-Rings or mechanical seal (copper or aluminium gaskets) junctions if possible.
- An external filter should always be installed in the suction line upstream the fuel unit.



ATTENTION: before the burner first start, it is mandatory to fill the adduction pipes with diesel fuel and bleed out residual air bubbles. Prior to switching on the burner, check direction of rotation of the pump motor by briefly pressing the starter switch; ensure there are no anomalous sounds during equipment operation, and only then turn on the burner. Neglect to comply with this requirement will invalidate the burner warranty.

| HP-Technick UHE-A.. | |
|-----------------------|----------------------------|
| Oil viscosity | 3 ÷ 75 cSt |
| Oil temperature | 0 ÷ 150°C |
| Min. suction pressure | - 0.45 bar to avoid gasing |
| Max. suction pressure | 5 bar |
| Max. return pressure | 5 bar |
| Rotation speed | 3600 rpm max. |

1. Connection for manometer 1 – delivery (M1) – G1/4
 2. Connection for manometer 2 – suction (M2) – G1/4
 3. Connection for manometer 3 (M3)
- A. Suction connection– G1/2
D. Direct - clockwise
I. Indirect – counter clockwise
R. By-pass connection– G1/2
S. Delivery connection – G1/2
VR. After removal of cover screw: pressure regulation

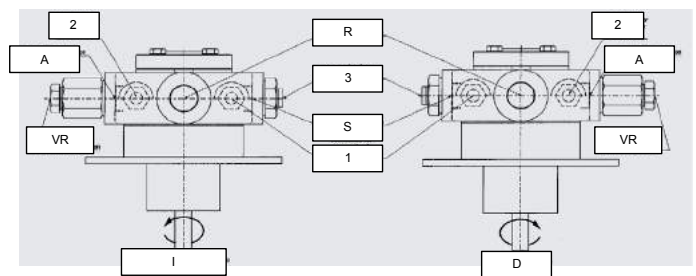

| Suntec T.. | |
|--------------------------|-----------------------------|
| Viscosity | 3 - 75 cSt |
| Oil temperature | 0 - 150 °C |
| Minimum suction pressure | - 0.45bar to prevent gasing |
| Maximum suction pressure | 5 bar |
| Rated speed | 3600 rpm max. |

Key

- 1 Inlet G3/4
- 2 Pressure gauge port G1/4
- 3 Vacuum gauge port to measure the inlet vacuum G1/4
- 4 To pressure adjusting valve G3/4

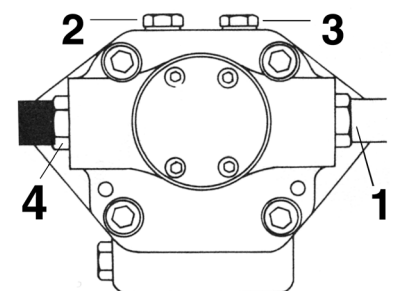

"Note: pump with "C" rotation.

| Suntec TA.. | |
|-----------------------|----------------------------|
| Oil viscosity | 3 ÷ 75 cSt |
| Oil temperature | 0 ÷ 150°C |
| Min. suction pressure | - 0.45 bar to avoid gasing |
| Max. suction pressure | 5 bar |
| Max. return pressure | 5 bar |
| Rotation speed | 3600 rpm max. |

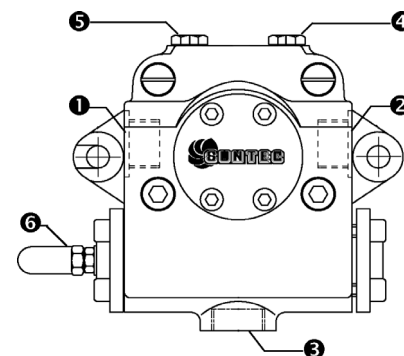

1. Inlet G1/2
2. To the nozzle G1/2
3. Return G1/2
4. Pressure gauge port G1/4
5. Vacuum gauge port G1/4
6. Pressure governor

Connecting the oil flexible hoses to the pump

To connect the flexible oil hoses to the pump, proceed as follows, according to the pump provided:

- 1 remove the closing nuts A and R on the inlet and return connections of the pump;
- 2 screw the rotating nut of the two flexible hoses on the pump **being careful to avoid exchanging the lines**: see the arrows marked on the pump.

For further information, refer to the technical documentation of the pump.

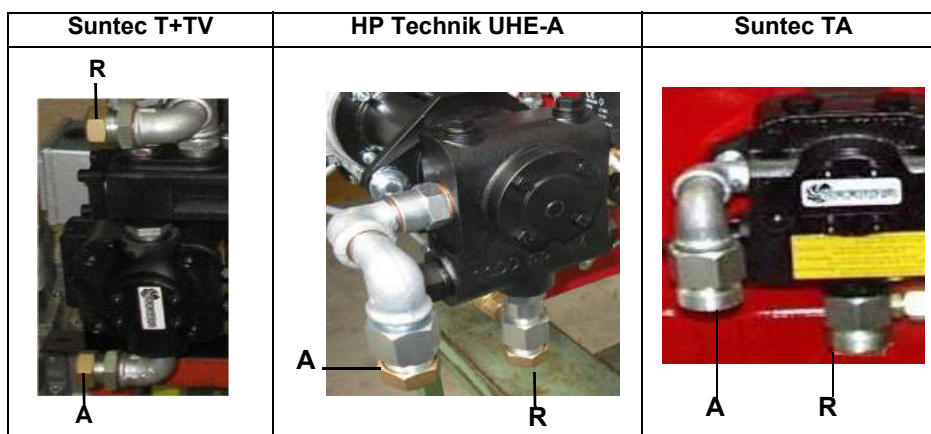

ELECTRICAL CONNECTIONS



WARNING! Respect the basic safety rules. make sure of the connection to the earthing system. do not reverse the phase and neutral connections. fit a differential thermal magnet switch adequate for connection to the mains. **WARNING!** before executing the electrical connections, pay attention to turn the plant's switch to OFF and be sure that the burner's main switch is in 0 position (OFF) too. Read carefully the chapter "WARNINGS", and the "Electrical connections" section.

ATTENTION: Connecting electrical supply wires to the burner terminal block MA, be sure that the ground wire is longer than phase and neutral ones.

To execute the electrical connections, proceed as follows:

- 1 remove the cover from the electrical board, unscrewing the fixing screws;
- 2 execute the electrical connections to the supply terminal board as shown in the attached wiring diagrams;
- 3 check the direction of the fan motor (see next paragraph);
- 4 refit the panel cover.



WARNING: (only for double stage and progressive burners) The burner is provided with an electrical bridge between terminals 6 and 7; when connecting the high/low flame thermostat, remove this bridge before connecting the thermostat.

Rotation of electric motor

Once the electrical connection of the burner is executed, remember to check the rotation of the electric motor. The motor should rotate according to the "arrow" symbol on the body. In the event of wrong rotation, reverse the three-phase supply and check again the rotation of the motor.



CAUTION: check the motor thermal cut-out adjustment

NOTE: the burners are supplied for three-phase 380 V or 400 V supply, and in the case of three-phase 220 V or 230 V supply it is necessary to modify the electrical connections into the terminal box of the electric motor and replace the overload tripped relay.

Note on electrical supply

In the case where the power supply of the AUXILIARIES of the phase-phase burner (without a neutral), for the flame detection it is necessary to connect the RC circuit Siemens between the terminal 2 (terminal X3-04-4 in case of LMV2x, LMV3x, LMV5x, LME7x) of the base and the earth terminal, RC466890660. For LMV5 control box, please refer to the labeling recommendations available on the Siemens CD attached to the burner.

Key

C - Capacitor (22nF/250V)

LME / LMV - Siemens control box

R - Resistor (1M Ω)

M:

- Terminal 2 (LGB, LME),

- Terminal X3-04-4 (LMV2x, LMV3x, LMV5, LME7x)

RC466890660 - RC Siemens filter

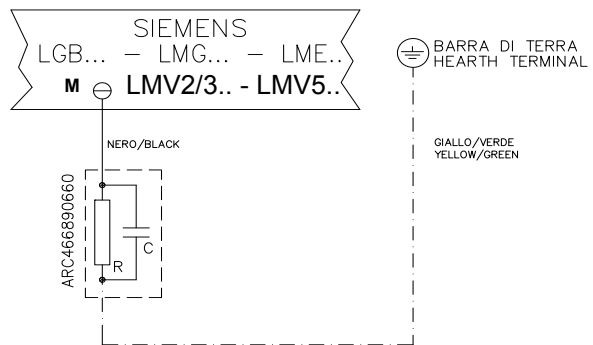

PART III: OPERATION



DANGER! Incorrect motor rotation can seriously damage property and injure people. **WARNING:** before starting the burner up, be sure that the manual cutoff valves are open and check that the pressure upstream the gas train complies the value quoted on paragraph "Technical specifications". Be sure that the mains switch is closed.

DANGER: During commissioning operations, do not let the burner operate with insufficient air flow (danger of formation of carbon monoxide); if this should happen, make the gas decrease slowly until the normal combustion values are achieved.

WARNING: never loose the sealed screws! otherwise, the device warranty will be immediately invalidate!

LIMITATIONS OF USE

THE BURNER IS AN APPLIANCE DESIGNED AND CONSTRUCTED TO OPERATE ONLY AFTER BEING CORRECTLY CONNECTED TO A HEAT GENERATOR (E.G. BOILER, HOT AIR GENERATOR, FURNACE, ETC.), ANY OTHER USE IS TO BE CONSIDERED IMPROPER AND THEREFORE DANGEROUS.

THE USER MUST GUARANTEE THE CORRECT FITTING OF THE APPLIANCE, ENTRUSTING THE INSTALLATION OF IT TO QUALIFIED PERSONNEL AND HAVING THE FIRST COMMISSIONING OF IT CARRIED OUT BY A SERVICE CENTRE AUTHORIZED BY THE COMPANY MANUFACTURING THE BURNER.

A FUNDAMENTAL FACTOR IN THIS RESPECT IS THE ELECTRICAL CONNECTION TO THE GENERATOR'S CONTROL AND SAFETY UNITS (CONTROL THERMOSTAT, SAFETY, ETC.) WHICH GUARANTEES CORRECT AND SAFE FUNCTIONING OF THE BURNER.

THEREFORE, ANY OPERATION OF THE APPLIANCE MUST BE PREVENTED WHICH DEPARTS FROM THE INSTALLATION OPERATIONS OR WHICH HAPPENS AFTER TOTAL OR PARTIAL TAMPERING WITH THESE (E.G. DISCONNECTION, EVEN PARTIAL, OF THE ELECTRICAL LEADS, OPENING THE GENERATOR DOOR, DISMANTLING OF PART OF THE BURNER).

NEVER OPEN OR DISMANTLE ANY COMPONENT OF THE MACHINE EXCEPT FOR ITS MAINTENANCE.

TO SECURE THE MACHINE, ACT ON THE ISOLATOR SWITCH. IN CASE OF ANOMALIES THAT REQUIRED A SHUT DOWN OF THE BURNER, IT'S POSSIBLE TO ACT ON THE AUXILIARY LINE SWITCH, LOCATED ON THE BURNER FRONT PANEL.

IN CASE OF A BURNER SHUT-DOWN, RESET THE CONTROL BOX BY MEANS OF THE RESET PUSHBUTTON. IF A SECOND SHUT-DOWN TAKES PLACE, CALL THE TECHNICAL SERVICE, WITHOUT TRYING TO RESET FURTHER.

WARNING: DURING NORMAL OPERATION THE PARTS OF THE BURNER NEAREST TO THE GENERATOR (COUPLING FLANGE) CAN BECOME VERY HOT, AVOID TOUCHING THEM SO AS NOT TO GET BURNT.

Fig. 12 - Burner front panel

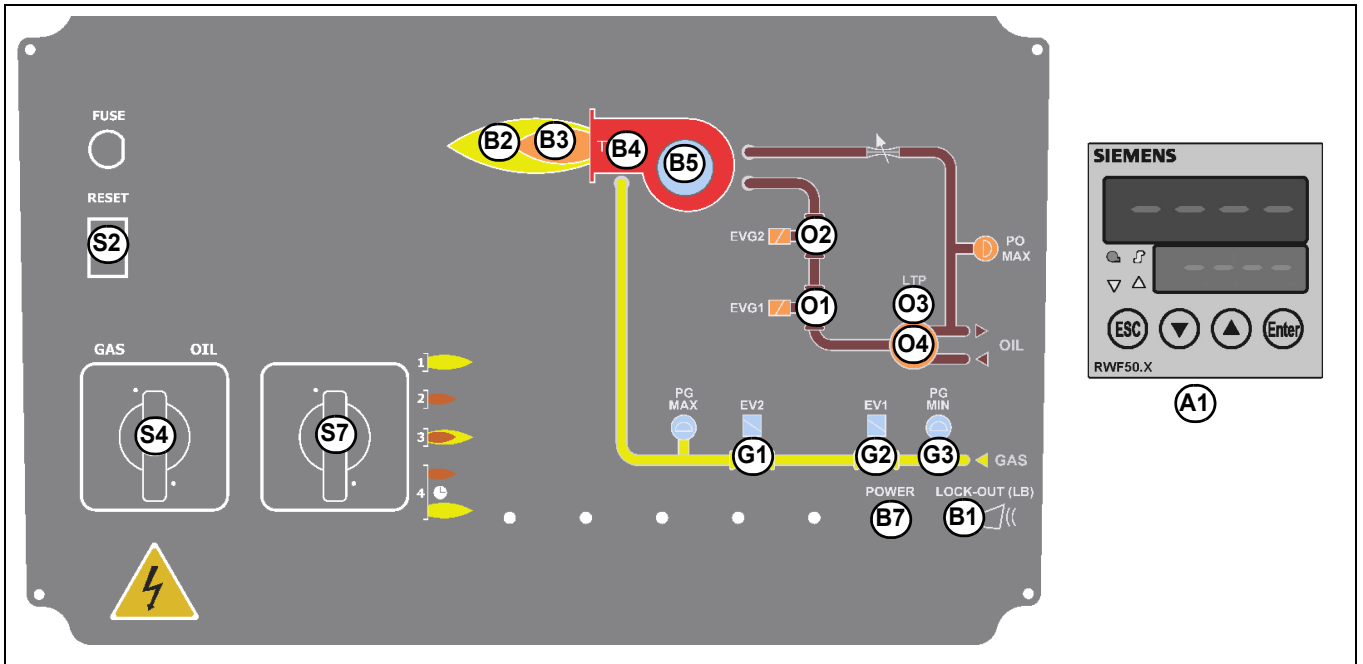

Keys

- B1 Lock-out LED
- B2 Hi-flame operation LED
- B3 Lo-flame operation LED
- B4 "Ignition transformer operation" LED
- B7 Burner ignition LED
- G1 "EV2 opening" LED
- G2 "EV1 opening" LED
- G3 "Gas pressure switch signal " LED
- S2 Reset pushbutton for control box
- S4 Fuel selection
- S7 CMF switch (0=stop, 1=high flame,2=low flame, 3=automatic) - fully modulating burners only
- O1 EVG1 solenoid valve operation LED
- O2 EVG2 solenoid valve operation LED
- O3 "Pump motor overload tripped" LED
- O4 Oil pump in operation LED
- A1 Burner Modulator (only on fully modulating burners)

Fig. 13 - Burner front panel

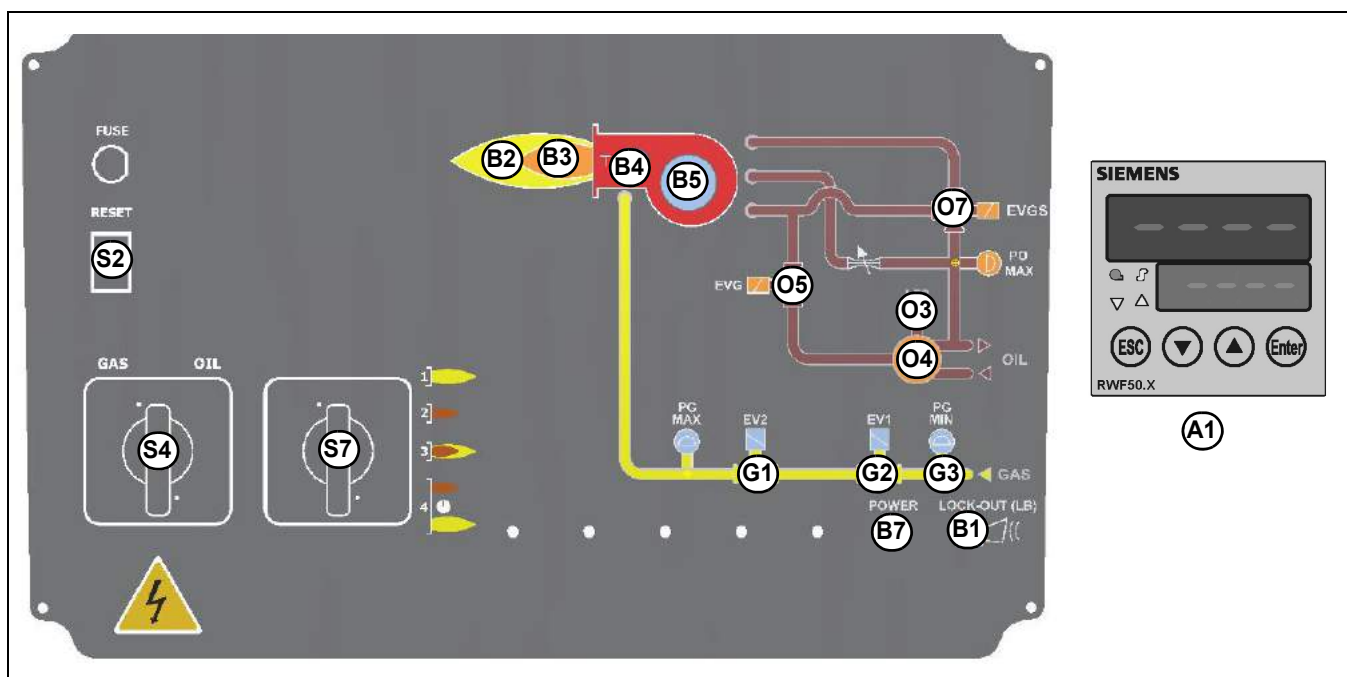
**Keys**

- B1 Lock-out LED
- B2 Hi-flame operation LED
- B3 Lo-flame operation LED
- B4 "Ignition transformer operation" LED
- B7 Burner ignition LED
- G1 "EV2 opening" LED
- G2 "EV1 opening" LED
- G3 "Gas pressure switch signal " LED
- S2 Reset pushbutton for control box
- S4 Fuel selection
- S7 CMF switch (0=stop, 1=high flame, 2=low flame, 3=automatic) - fully modulating burners only
- O3 "Pump motor overload tripped" LED
- O4 Oil pump in operation LED
- O5 Oil valve EVG operation signalling lamp
- O7 Oil valve EVGS operation signalling lamp
- A1 Burner Modulator (only on fully modulating burners)

Fuel selection:

- In order to start the burner with gas or light oil, the operator must commute the selector on the burner control panel on (1) = gas, or (2) = light oil.
If the selector is set on (1) the gas cock must be open, while the light oil cock must be closed. Viceversa if the selector is set on (2).
CAUTION: if the fuel chosen is oil, be sure the cutoff valves on the feed and return pipes are open.
- Check the control box is not locked (signalling light **B1**, on); if so, reset it by means of the reset button.
- Check the series of thermostats and pressure switches turn the burner to on.

Gas operation

- Check the gas feeding pressure is sufficient (signalling lamp **G3** on).
- **Burners fitted with gas proving system:** the gas proving system test begins; when the test is performed the proving system LED turns on. At the end of the test, the burner starting cycle begins: in case of leakage in a valve, the gas proving system stops the burner and the lamp **B1** turns on.

NOTE: if the burner is fitted with Dungs VPS504, the pre-purge phase starts once the gas proving system is successfully performed. Since the pre-purge phase must be carried out with the maximum air rate, the control box drives the actuator opening and when the maximum opening position is achieved, the pre-purge time counting starts.

- At the end of the pre-purge time, the actuator drives the complete closing (ignition with gas position) and, as this is achieved the ignition transformer is energised (LED **B4** is on); the gas valves open.
- Few seconds after the valves opening, the transformer is de-energised and lamp **B4** turns off.
- The burner is now operating, meanwhile the actuator goes to the high flame position and, after some seconds, the two-stage operation begins; the burner is driven automatically to high flame or low flame, according to the plant requirements.

Operation in high or low flame is signalled by lamp **B2** on the frontal panel.

Light oil operation

- The fan motor starts and the pre-purge phase as well. Since the pre-purge phase must be carried out at the maximum air rate, the control box drives the actuator opening and when the maximum opening position is reached, the pre-purge time counting starts.
- At the end of the pre-purge time, the actuator is in the light oil ignition position: the ignition transformer is energised (lamp **B4** on); the ignitor gas valves (if provided) and the light oil valves open. Few seconds after the valves opening, the transformer is de-energised and lamp **B4** turns off.
- The burner is now operating, meanwhile the actuator goes to the high flame position; after some seconds, the two-stage operation begins; the burner is driven automatically to high flame or low flame, according to the plant requirements. Operation in high or low flame is signalled by LED **B2** on the burner control panel.

The fuel is pushed into the pump to the nozzle at the delivery pressure set by the pressure governor. The solenoid valve stops the fuel immission into the combustion chamber. The fuel flow rate that is not burnt goes back to the tank through the return circuit. The nozzle is feeded at constant pressure, while the return line pressure is adjusted by means of the pressure governor controlled by an actuator.

AIR FLOW AND FUEL ADJUSTMENT

WARNING! During commissioning operations, do not let the burner operate with insufficient air flow (danger of formation of carbon monoxide); if this should happen, make the fuel decrease slowly until the normal combustion values are achieved.

WARNING! the combustion air excess must be adjusted according to the values in the following chart.

| Recommended combustion parameters | | |
|-----------------------------------|---------------------------------|--------------------------------|
| Fuel | Recommended (%) CO ₂ | Recommended (%) O ₂ |
| Natural gas | 9 ÷ 10 | 3 ÷ 4.8 |
| Light oil | 11.5 ÷ 13 | 2.9 ÷ 4.9 |
| LPG | 11 ÷ 12 | 2.8 ÷ 4.3 |

Adjustments - brief description

Adjust the air and gas flow rates at the maximum output ("high flame") first, by means of the air damper and the adjusting cam respectively.

- Check that the combustion parameters are in the suggested limits.
- Check the flow rate measuring it on the counter or, if it was not possible, verifying the combustion head pressure by means of a differential pressure gauge.
- Then, adjust the combustion values corresponding to the points between maximum and minimum: set the shape of the adjusting cam foil. The adjusting cam sets the air/gas ratio in those points, regulating the opening-closing of the throttle gas valve.
- Set, now, the low flame output, acting on the low flame microswitch of the actuator in order to avoid the low flame output increasing too much or that the flues temperature gets too low to cause condensation in the chimney.

ADJUSTMENTS FOR GAS OPERATION

Adjustments - brief description

- Adjust the air and gas flow rates at the maximum output (“high flame”) first, by means of the air damper and the valves group pressure stabiliser respectively.
- Check that the combustion parameters are in the suggested limits.
- Check the flow rate measuring it on the counter or, if it was not possible, verifying the combustion head pressure by means of a differential pressure gauge, as described on par. “Measuring the gas pressure in the combustion head”.
- Then, adjust the combustion values corresponding to the points between maximum and minimum (progressive -fully modulating burners only): set the shape of the adjusting cam foil. The adjusting cam sets the air/gas ratio in those points, regulating the opening-closing of the air damper.
- Set, now, the low flame output, acting on the low flame microswitch of the actuator in order to avoid the low flame output increasing too much or that the flues temperature gets too low to cause condensation in the chimney.

To change the burner setting during the testing in the plant, follows the next procedure, according to the model provided.

Air and Gas Flow Rate Settings by means of Berger STM30../Siemens SQM40.. actuator

- 1 check the fan motor rotation.
- 2 Only for burners provided with **Multibloc MB-DLE gas valves**: before starting the burner up, set the slow opening. To set the slow opening, remove cover **T**, reverse it upside down and use it as a tool to rotate screw **VR**. Clockwise rotation reduces start flow rate, anticlockwise rotation increases it. Do not use a screwdriver on the screw **VR**!

Note: the screw **VSB** must be removed only in case of replacement of the coil.

- 3 Before starting the burner up, drive the high flame actuator microswitch matching the low flame one (in order to let the burner operates at the lowest output) to safely achieve the high flame stage.
- 4 Start the burner up by means of the thermostat series and wait until the pre-purge time comes to an end and that the burner starts up;
- 5 drive the burner to high flame stage, by means fo the thermostat **TAB**.
- 6 Then move progressively the microswitch to higher values until it reaches the high flame position; always check the combustion values and eventually adjusting the gas by means of the valves group stabiliser.
- 7 go on adjusting air and gas flow rates: check, continuously, the flue gas analysys, as to avoid combustion with little air; dose the air according to the gas flow rate change following the steps quoted below;

SQM40.265 CSW Actuator cams



- 8 acting on the pressure stabiliser of the valves group, adjust the **gas flow rate in the high flame stage** as to meet the values requested by the boiler/utilisation:

- **Siemens VGD valves group**: remove cap **T** and act on the **VR** adjusting screw to increase or decrease the pressure and consequently the gas rate; screwing **VR** the rate increases, unscrewing it decreases (see next figure).

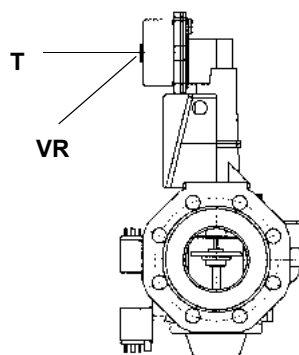

Siemens VGD..

- 9 To adjust the **air flow rate in the high flame stage**, loose the **RA** nut and screw **VRA** as to get the desired air flow rate: moving

the rod **TR** towards the air damper shaft, the air damper opens and consequently the air flow rate increases, moving it far from the shaft the air damper closes and the air flow rate decreases.

Note: once the procedure is performed, be sure that the blocking nut **RA** is fastened. Do not change the position of the air damper rods.

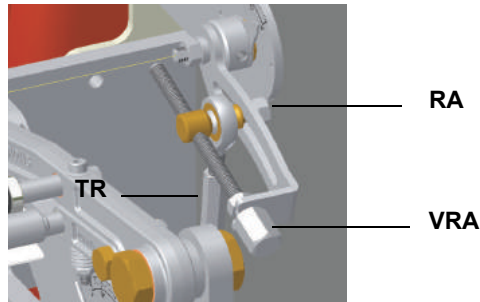

10 If necessary, adjust the combustion head position (see the dedicated paragraph)..

⚠ Attention! if it is necessary to change the head position, repeat the air and gas adjustments described above.

- 11 The air and gas rate are now adjusted at the maximum power stage, go on with the point to point adjustment on the **SV1** (gas side) adjusting cam as to reach the minimum output point.
- 12 as for the point-to-point regulation, move the gas low flame microswitch a little lower than the maximum position (90°);
- 13 set the **TAB** thermostat to the minimum in order that the actuator moves progressively towards the low flame position;
- 14 move the gas low flame microswitch to the minimum to move the actuator towards the low flame until the two bearings find the adjusting screw that refers to the lower position: screw **V1** to increase the rate, unscrew to decrease.

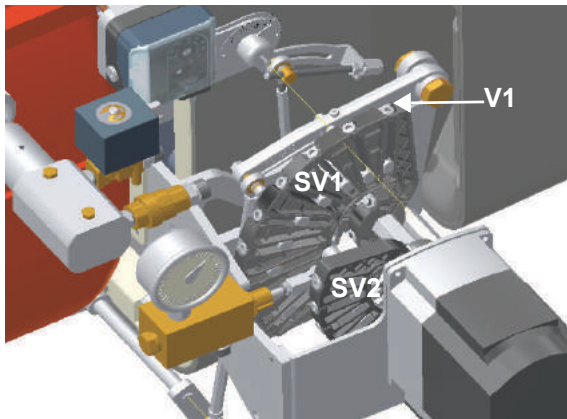

Gas throttle valve open

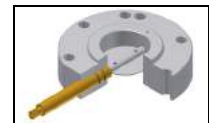

Gas throttle valve closed

- 15 Move again the gas low flame microswitch towards the minimum to meet the next screw on the adjusting cam and repeat the previous step; go on this way as to reach the desired low flame point.
- 16 Now adjust the pressure switches.

Fully-modulating burners

To adjust the fully-modulating burners, use the **CMF** switch on the burner control panel (see next picture), instead of the **TAB** thermostat as described on the previous paragraphs about the progressive burners. Go on adjusting the burner as described before, paying attention to use the **CMF** switch instead of **TAB**.

The **CMF** position sets the operating stages: to drive the burner to the high-flame stage, set **CMF=1**; to drive it to the low-flame stage, set **CMF=2**.



CMF

- CMF = 0 stop at the current position
- CMF = 1 high flame operation
- CMF = 2 low flame operation
- CMF = 3 automatic operation

MultiBloc MBE Regulation VD-R with PS

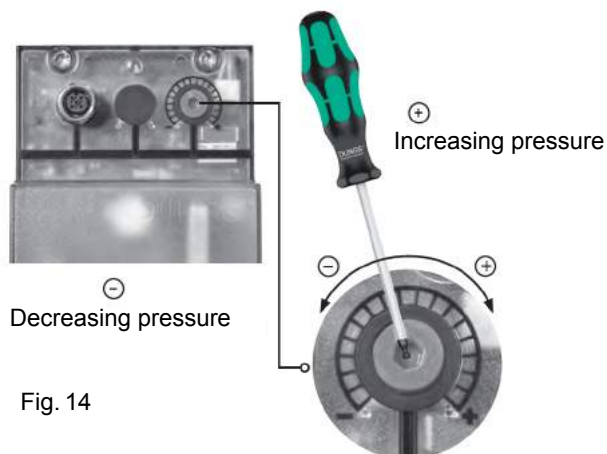

Setting scale is „Not“ linear! Various sensors available. Output pressure according to sensor's measuring range.



Adjust the outlet pressure to the value specified by the burner or equipment manufacturer!



While making outlet pressure adjustments, do not exceed a value that creates a hazardous condition to the burner!

Fig. 14

ATTENTION: To set the outlet pressure of the VD-R regulator, act on the adjustment ring nut (Fig. 10). The position of the indicator in the dial indicates the value of the outlet pressure calculated as a percentage of the full scale of the PS sensor (Fig. 11)

| Outlet pressure | MIN | 10% | 25% | 50% | 75% | MAX |
|------------------|-------------------------------|--------------------------------|----------------------------------|-----------------------------------|-----------------------------------|-----------------------------------|
| PS-10/40 | 4 mbar 0,4 kPa 2 "w.c. | 10 mbar 1,0 kPa 4 "w.c. | 25 mbar 2,5 kPa 10 "w.c. | 50 mbar 5,0 kPa 20 "w.c. | 75 mbar 7,5 kPa 30 "w.c. | 100 mbar 10,0 kPa 40 "w.c. |
| PS-50/200 | 20 mbar 2,0 kPa 8 "w.c. | 50 mbar 5,0 kPa 20 "w.c. | 125 mbar 12,5 kPa 50 "w.c. | 250 mbar 25,0 kPa 100 "w.c. | 375 mbar 37,5 kPa 150 "w.c. | 500 mbar 50,0 kPa 200 "w.c. |

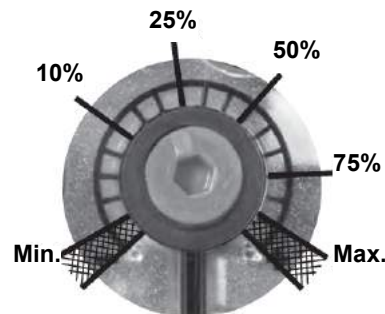

Fig. 15

Adjusting output pressure for positive pressure systems (requires PS-10/40 or PS-50/200):

Pressure taps MultiBloc MBE

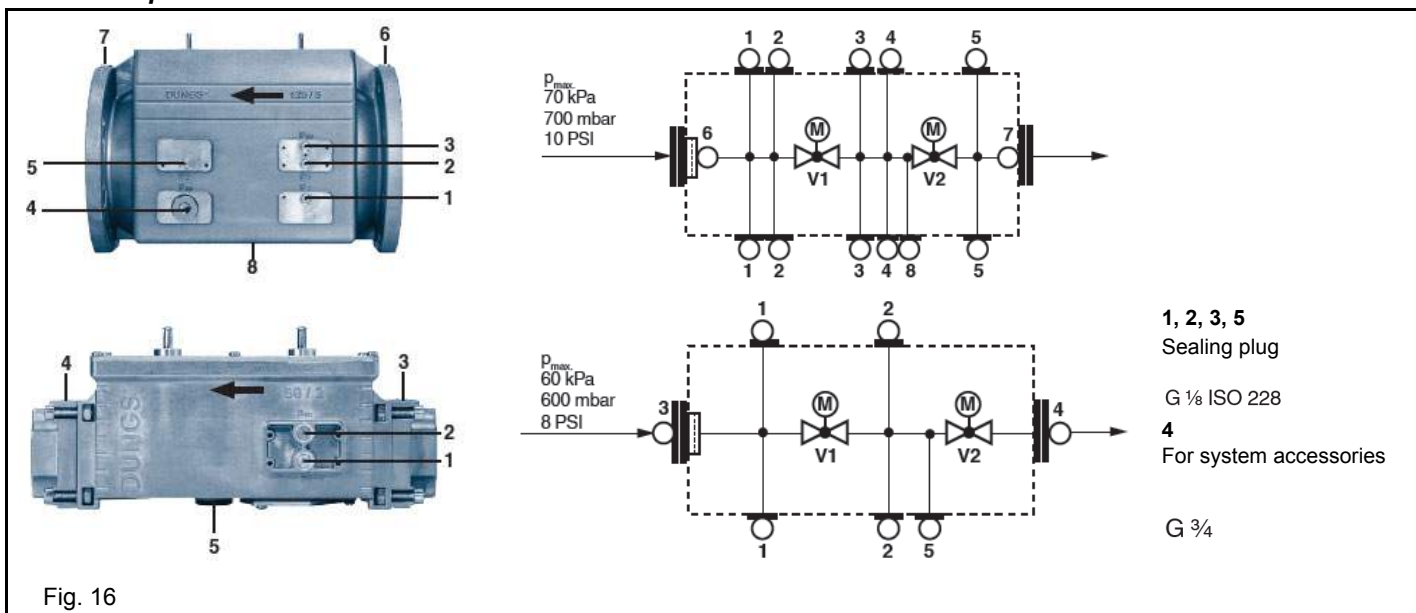

Fig. 16

Gas valve version with SKP2 (built-in pressure stabilizer)

To increase or decrease gas pressure, and therefore gas flow rate, remove the cap T and use a screwdriver to adjust the regulating screw VR. Turn clockwise to increase the flow rate, counterclockwise to reduce it.



Calibration of low gas pressure switch

As for the gas pressure switch calibration, proceed as follows:

- Be sure that the filter is clean.
- Remove the transparent plastic cap.
- While the burner is operating at the maximum output, test the gas pressure on the pressure port of the minimum gas pressure switch.
- Slowly close the manual cutoff valve (placed upstream the pressure switch, see gas train installation diagram), until the detected pressure is reduced by 50%. Pay attention that the CO value in the flue gas does not increase: if the CO values are higher than the limits laid down by law, slowly open the cutoff valve as to get values lower than these limits.
- Check that the burner is operating correctly.
- Clockwise turn the pressure switch adjusting ring nut (as to increase the pressure value) until the burner stops.
- Slowly fully open the manual cutoff valve.
- Refit the transparent plastic cover on the pressure switch.

Calibration the maximum gas pressure switch (when provided)

To calibrate the maximum pressure switch, proceed as follows according to its mounting position:

- remove the pressure switch plastic cover;
- if the maximum pressure switch is mounted upstream the gas valves: measure the gas pressure in the network, when flame is off; by means of the adjusting ring nut **VR**, set the value read, increased by the 30%.
- if the maximum pressure switch is mounted downstream the "gas governor-gas valves" group and upstream the butterfly valve: light the burner, adjust it according to the procedure in the previous paragraph. Then, measure the gas pressure at the operating flow rate, downstream the "gas governor-gas valves" group and upstream the butterfly valve; by means of the adjusting ring nut **VR**, set the value read on step 2, increased by the 30%;
- replace the plastic cover.

Calibration of air pressure switch

To calibrate the air pressure switch, proceed as follows:

- Remove the transparent plastic cap.
- Once air and fuel setting have been accomplished, startup the burner.
- During the pre-purge phase of the operation, turn slowly the adjusting ring nut **VR** in the clockwise direction (to increase the adjusting pressure) until the burner lockout, then read the value on the pressure switch scale and set it to a value reduced by 15%.
- Repeat the ignition cycle of the burner and check it runs properly.
- Refit the transparent plastic cover on the pressure switch.

Calibration gas leakage pressure switch (PGCP)

- remove the pressure switch plastic cover;
- adjust the PGCP pressure switch to the same value set for the minimum gas pressure switch;
- replace the plastic cover.

Adjusting the combustion head

Attention! if it is necessary to change the head position, repeat the air and fuel adjustments described above.

Only if necessary, change the combustion head position: to let the burner operate at a lower output, loose the **VB** screw and move progressively back the combustion head towards the MIN position, by turning clockwise the **VRT** ring nut. Fasten **VB** screw when the adjustment is accomplished.

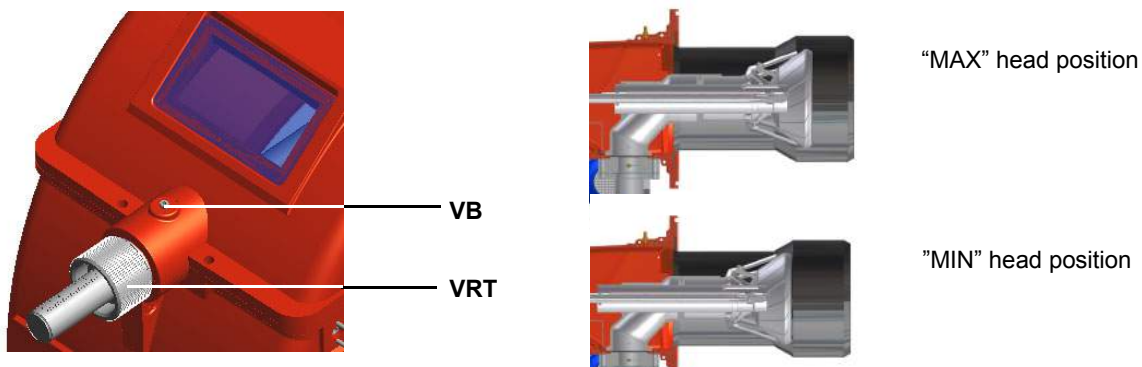

CAUTION: perform these adjustments once the burner is turned off and cooled.

Center head holes gas flow regulation (natural gas burners)

To adjust the gas flow, partially close the holes, as follows:

- 1 loosen the three **V** screws that fix the adjusting plate **D**;
- 2 insert a screwdriver on the adjusting plate notches and let it move CW/CCW as to open/close the holes;
- 3 once the adjustment is performed, fasten the **V** screws.

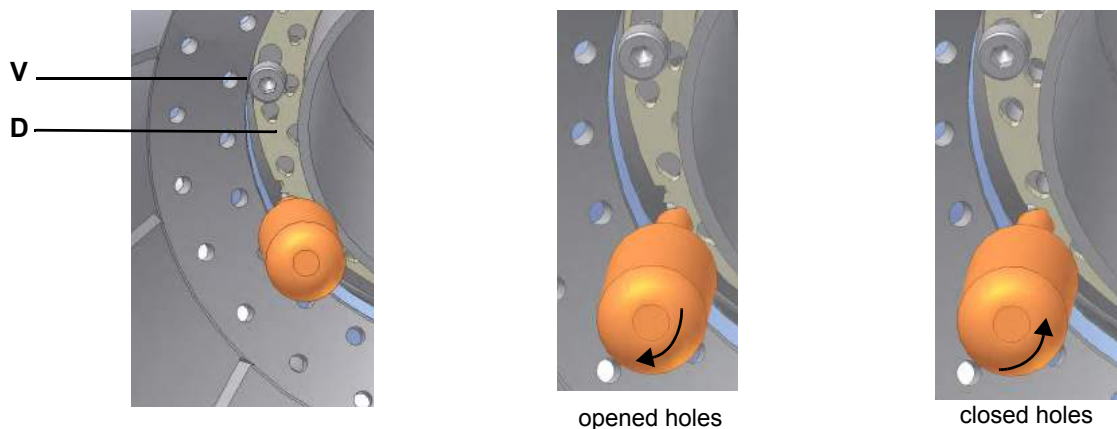

The adjusting plate correct position must be regulated in the plant during the commissioning.

The factory setting depends on the type of fuel for which the burner is designed:

- For natural gas burners, plate holes are fully opened

Center head holes gas flow regulation (LPG burners)

To adjust the gas flow, partially close the holes, as follows:

- 1 loosen the three **V** screws that fix the adjusting plate **D**;
- 2 insert a screwdriver on the adjusting plate notches and let it move CW/CCW as to open/close the holes;
- 3 once the adjustment is performed, fasten the **V** screws.

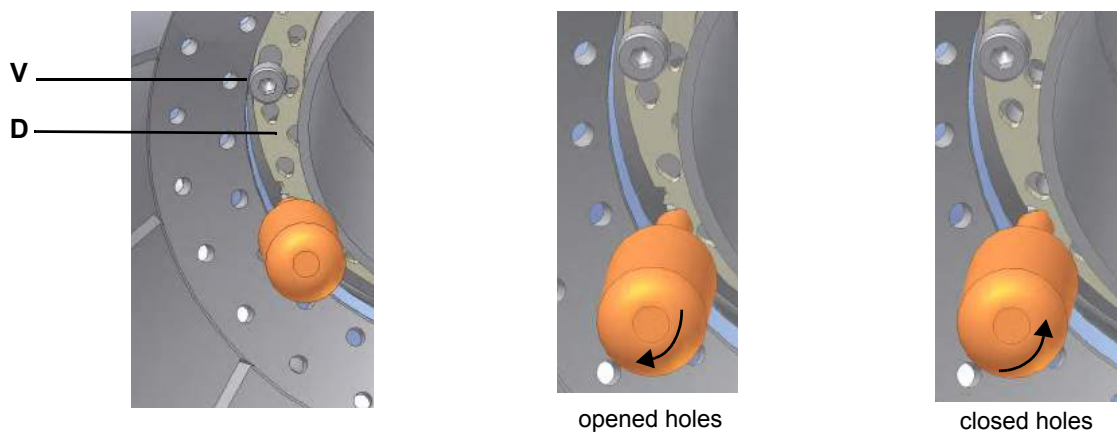

The adjusting plate correct position must be regulated in the plant during the commissioning.

The factory setting depends on the type of fuel for which the burner is designed:

- For LPG burners, plate holes are opened about:
 - 9xA series: 1.5 mm
 - 5xA series: 1.3 mm

Adjustment procedure for light oil operation

The light oil flow rate can be adjusted choosing a by-pass nozzle that suits the boiler/utilisation output and setting the delivery and return pressure values according to the ones quoted on the below diagrams.

FLUIDICS NOZZLE: REFERENCE DIAGRAM (INDICATIVE ONLY)

| DIMENSIONS | FLOW RATE kg/h | | Indicative pressure on return (bar) |
|------------|----------------|-----|-------------------------------------|
| | Min | Max | |
| 40 | 13 | 40 | 19 |
| 50 | 16 | 50 | 22 |
| 60 | 20 | 60 | 20 |
| 70 | 23 | 70 | 23 |
| 80 | 26 | 80 | 23 |
| 90 | 30 | 90 | 22 |
| 100 | 33 | 100 | 22 |
| 115 | 38 | 115 | 21 |
| 130 | 43 | 130 | 22 |
| 145 | 48 | 145 | 21 |
| 160 | 53 | 160 | 21 |
| 180 | 59 | 180 | 22 |
| 200 | 66 | 200 | 21 |
| 225 | 74 | 225 | 22 |
| 250 | 82 | 250 | 22 |
| 275 | 91 | 275 | 22 |
| 300 | 99 | 300 | 23 |
| 330 | 109 | 330 | 23 |
| 360 | 119 | 360 | 22 |
| 400 | 132 | 400 | 22 |
| 450 | 148 | 450 | 22 |
| 500 | 165 | 500 | 22 |
| 550 | 181 | 550 | 22 |
| 600 | 198 | 600 | 23 |
| 650 | 214 | 650 | 23 |
| 700 | 231 | 700 | 23 |
| 750 | 250 | 750 | 23 |
| 800 | 267 | 800 | 22 |

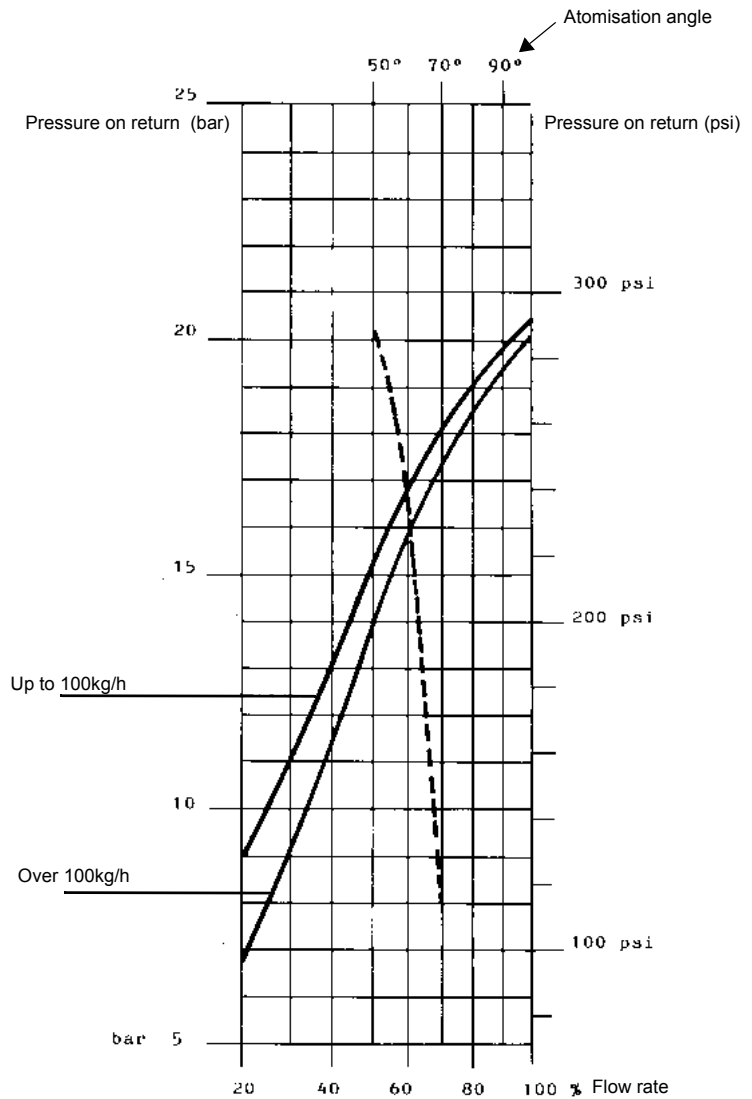

NOZZLE SUPPLY PRESSURE = 25 bar

----- Atomisation angle according to the return pressure
 ————— % Flow rate
 viscosity at nozzle = 5 cSt

Tab. 1



ATTENTION! To achieve the maximum flow rate close completely the return line.

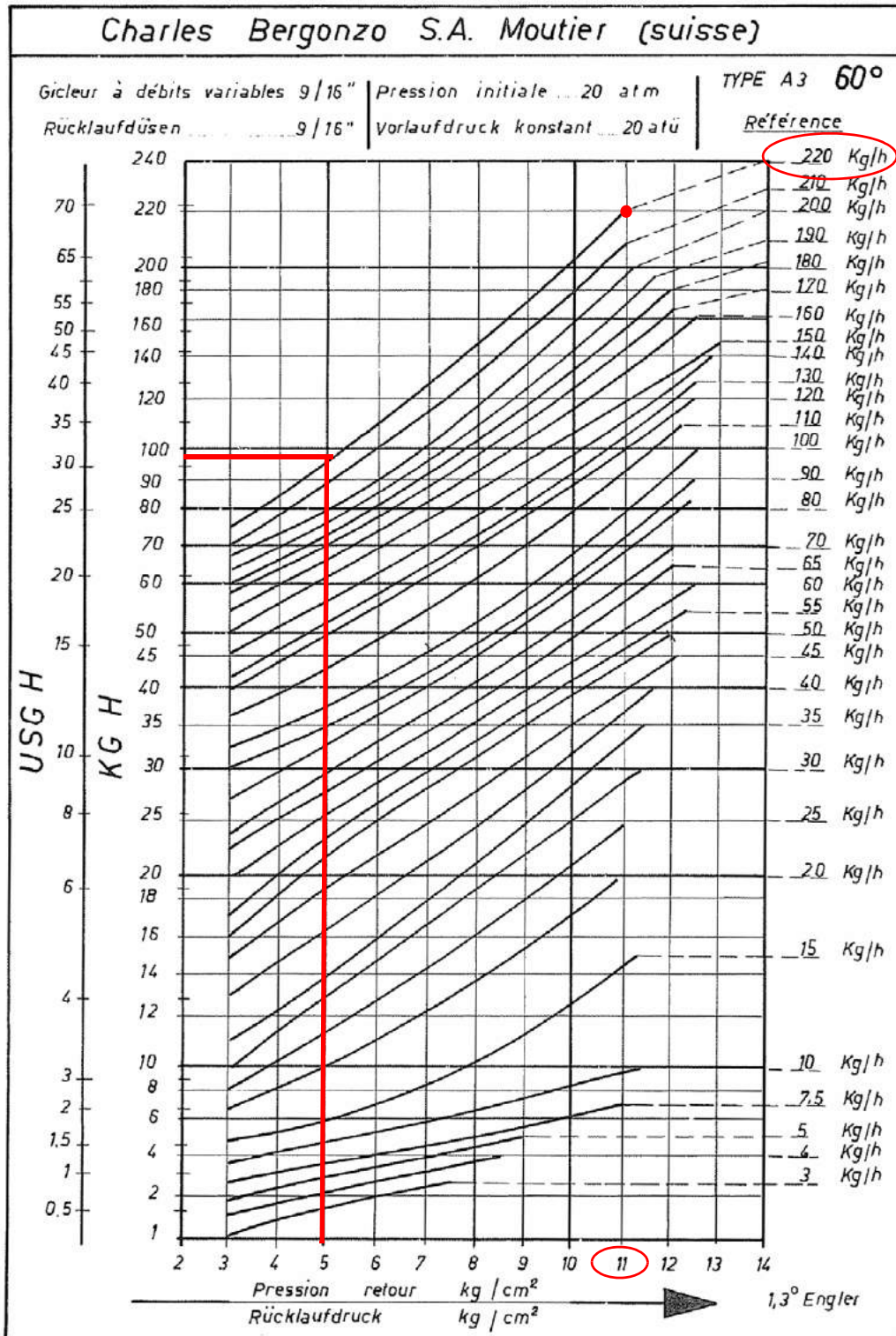

Example (Bergonzo): if a 220kg/h flow rate BERGONZO nozzle is provided, set the return pressure at 11bar, supply at 20bar on the delivery to get a 220kg/h flow rate. If the return pressure needed is 5bar, instead, act on the **V** adjusting screw on the pressure governor. The flow rate will then be about 95kg/h (see the example showed on the Bergonzo diagram).

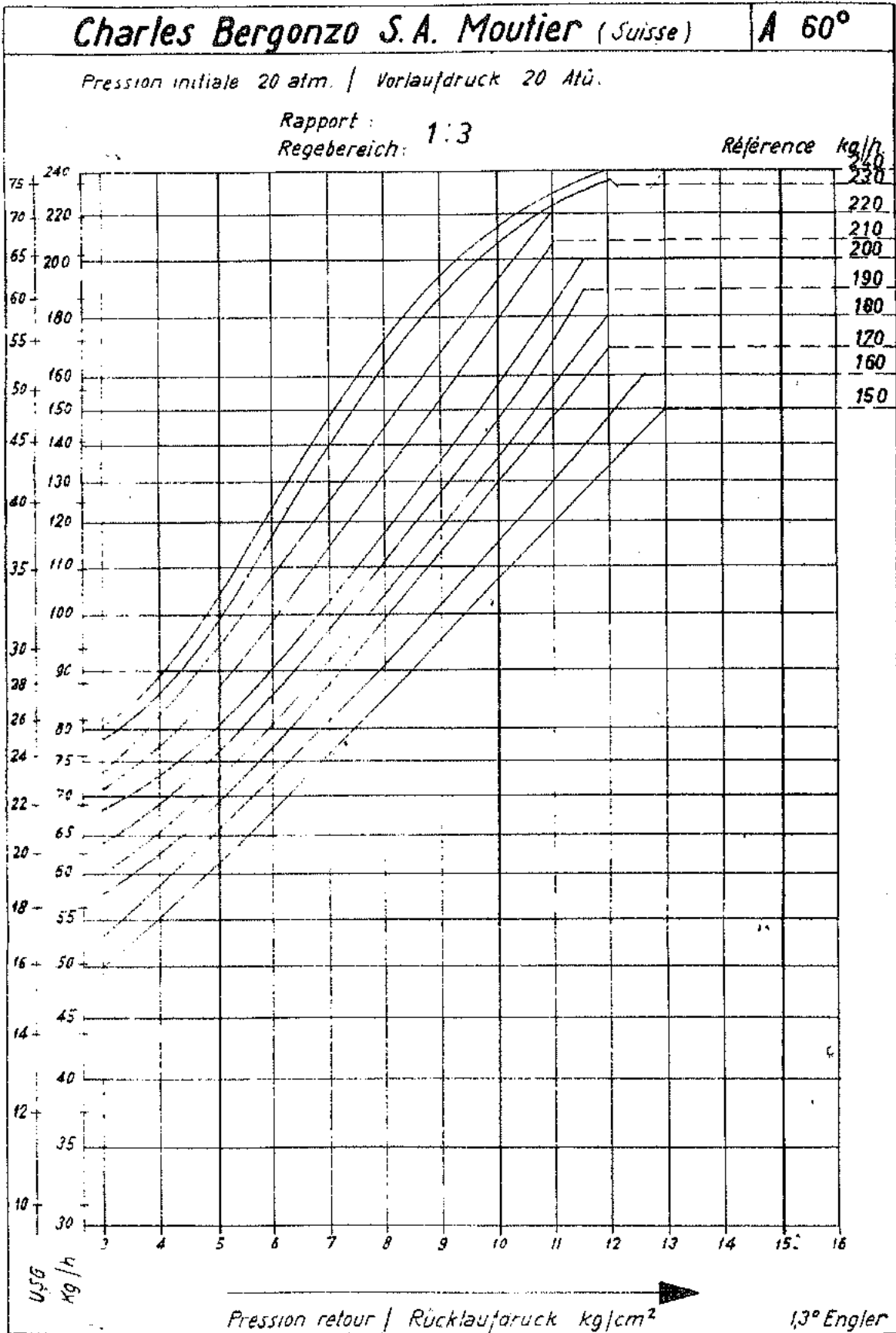

Fig. 17

Charles Bergonzo S.A. Moutier (suisse)

Gicleurs à retour... 9/16" | Pression initiale 20 atm
 Rücklaufdüsen..... 9/16" | Vorlaufdruck konstant... 20 atü

TYPE A3

Référence

250 Kg/h
60°

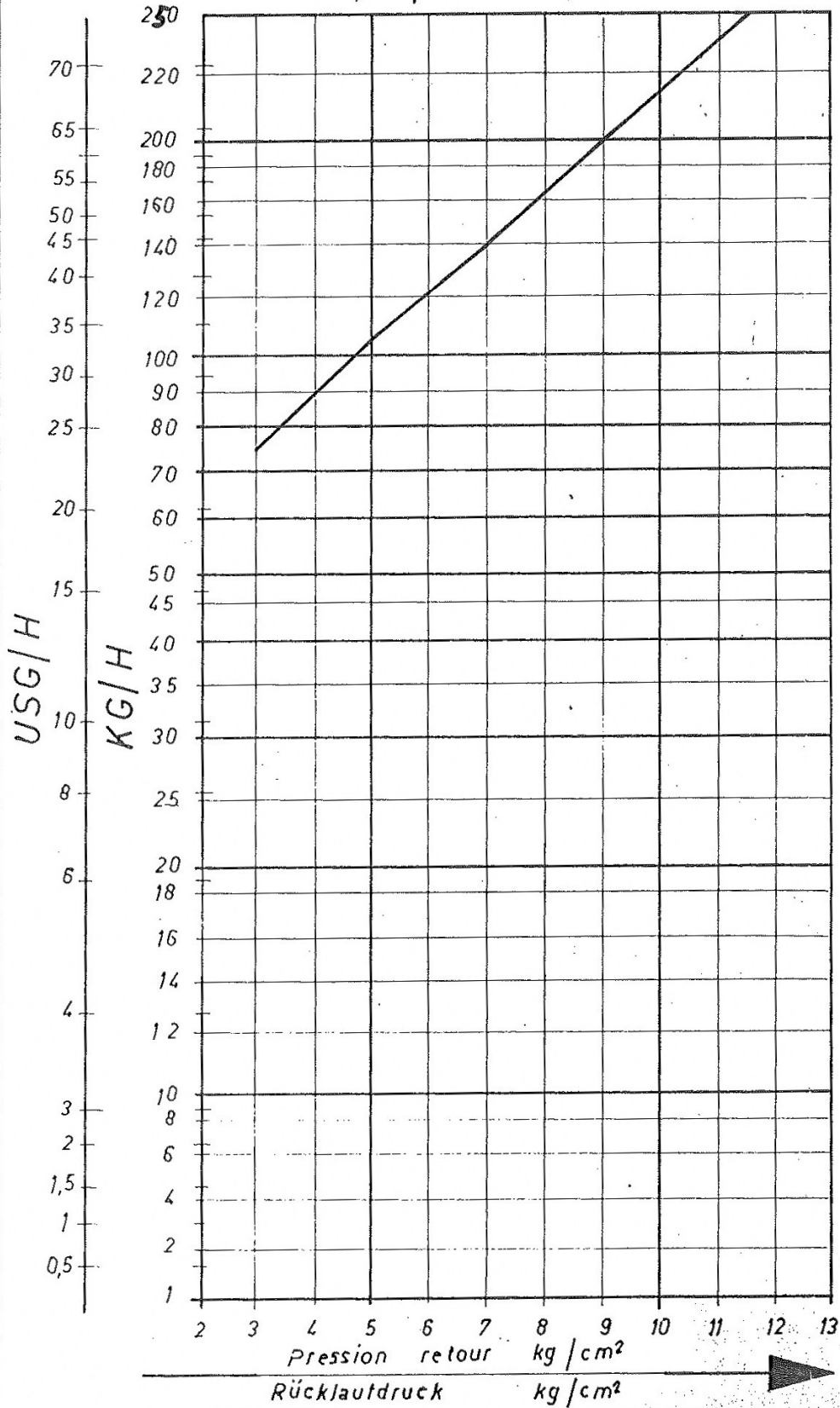

Engler 1,3°

FLUIDICS KW3...60°

NOZZLE SUPPLY PRESSURE = 20 bar. VISCOSITY AT NOZZLE = 5 cSt

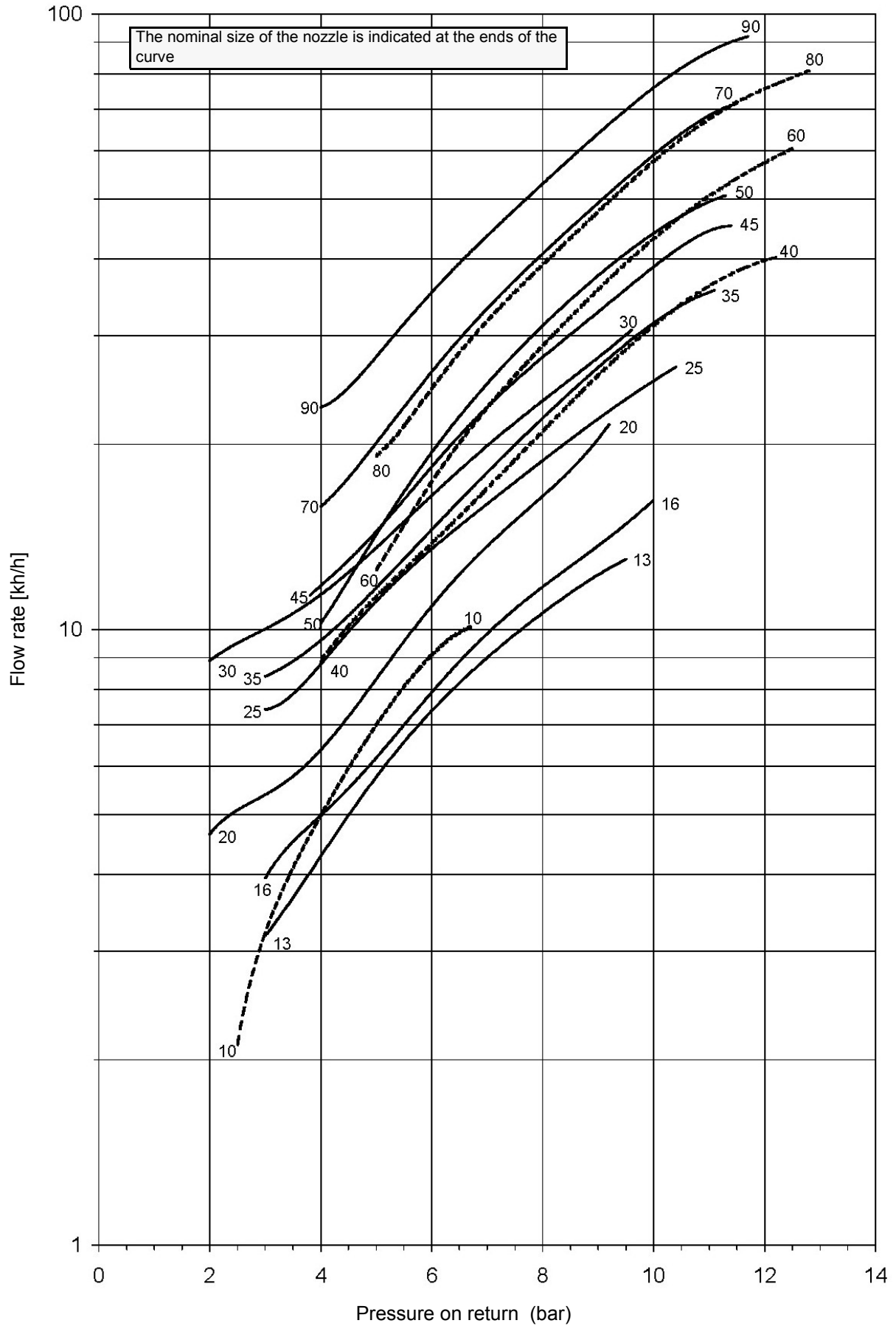

FLUIDICS KW3...60°

NOZZLE SUPPLY PRESSURE = 20 bar. VISCOSITY AT NOZZLE = 5 cSt

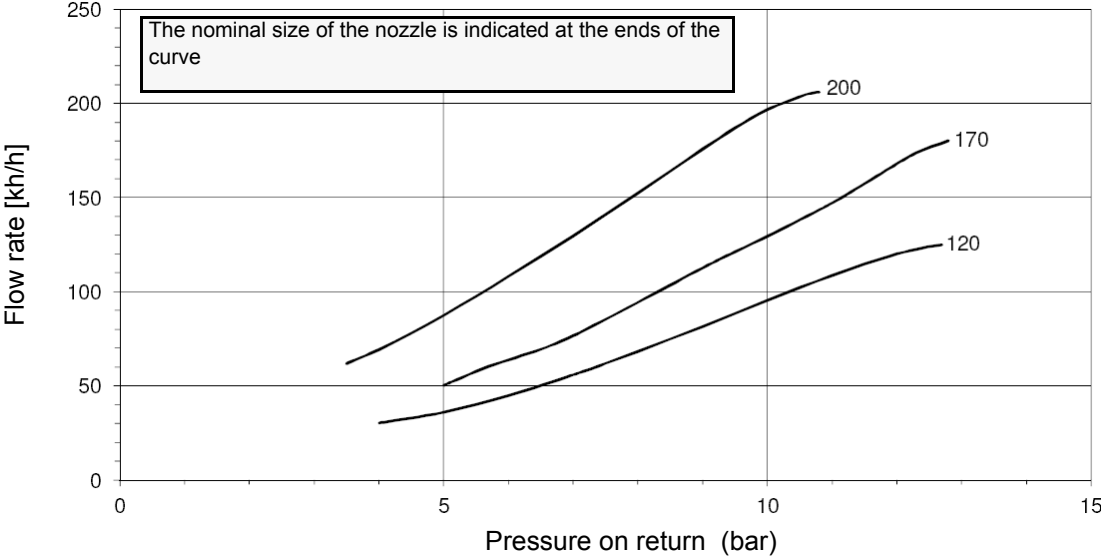
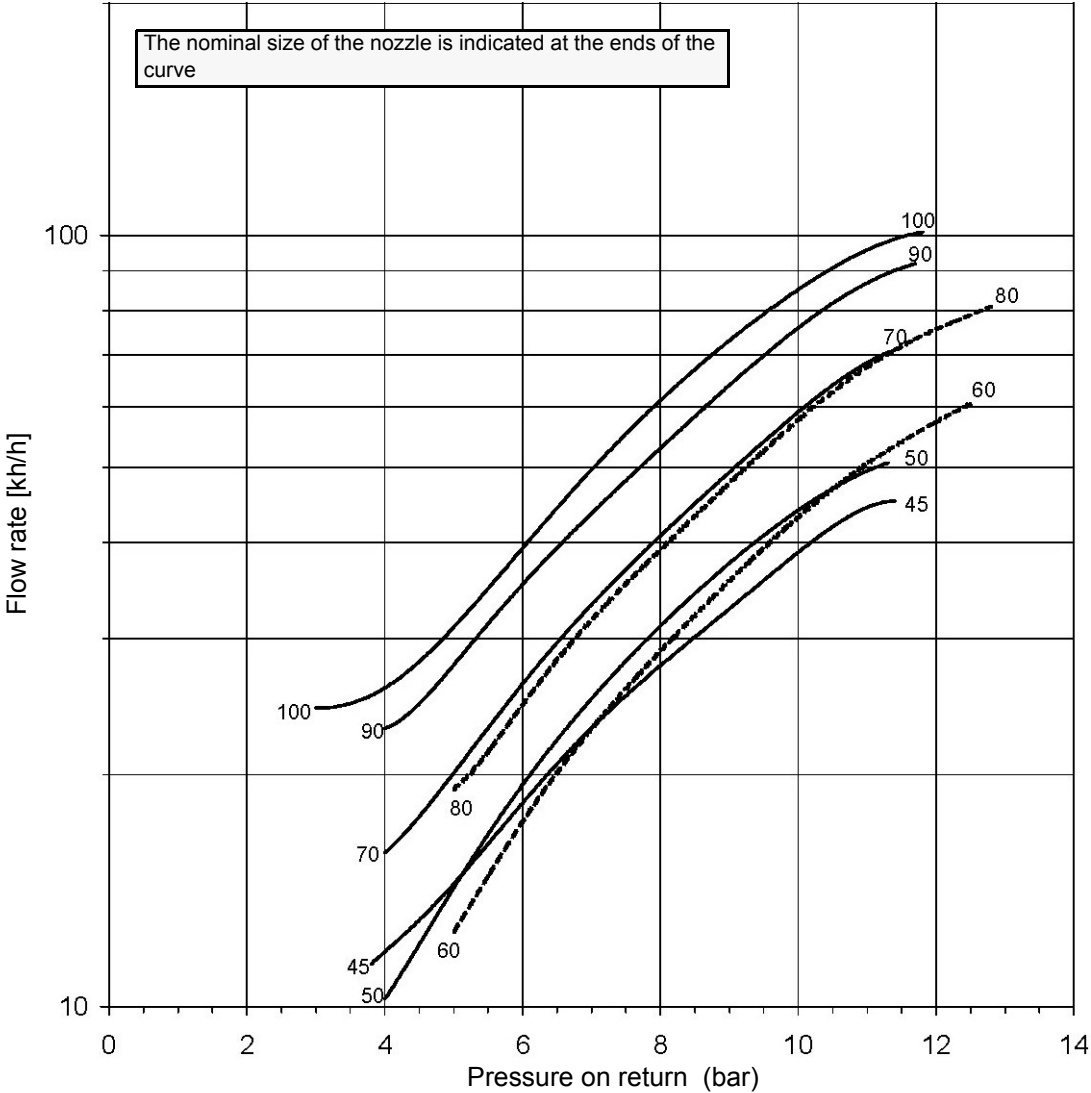

FLUIDICS KW3...60°

NOZZLE SUPPLY PRESSURE = 20 bar. VISCOSITY AT NOZZLE = 5 cSt

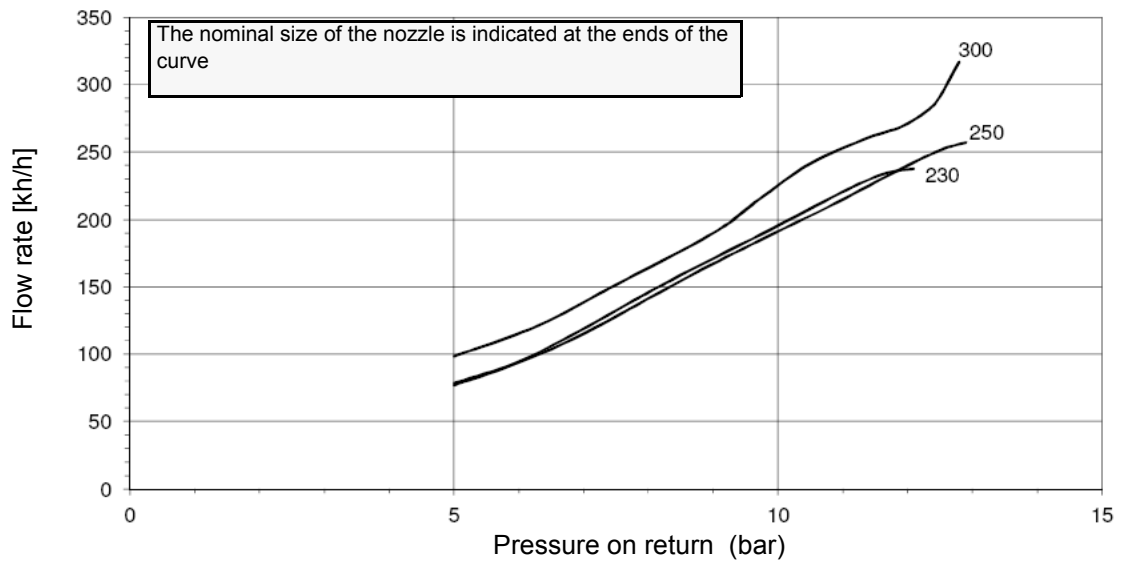
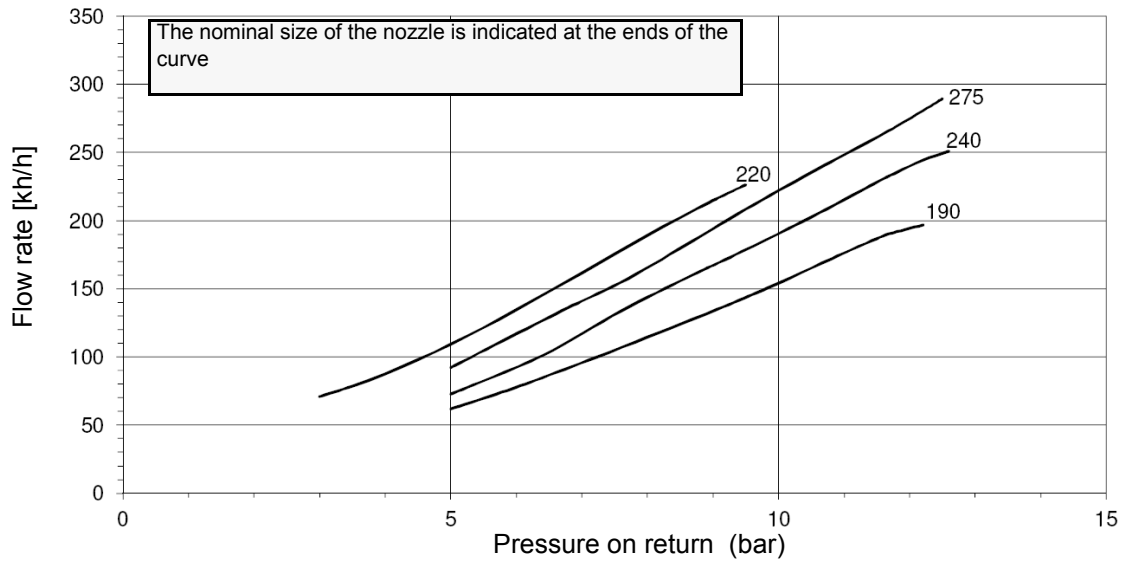
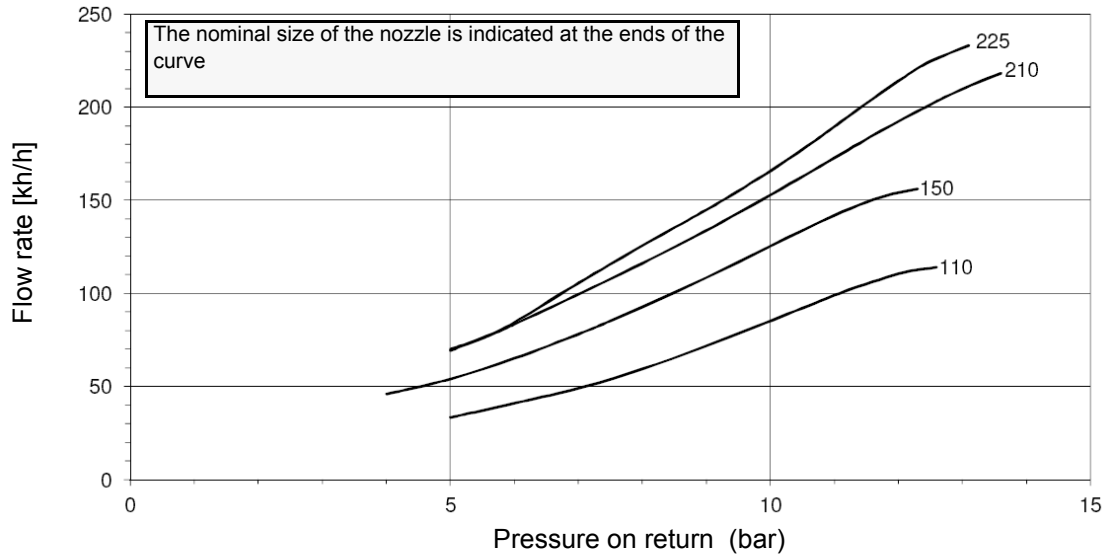

Oil Flow Rate Settings

- 1 Once the air and gas flow rates are adjusted, turn the burner off, switch to the oil operation (OIL, on the burner control panel).
- 2 with the electrical panel open, prime the oil pump acting directly on the related **CP** contactor (see next picture): check the pump motor rotation and keep pressing for some seconds until the oil circuit is charged;



- 3 bleed the air from the **M** pressure gauge port by loosening the cap without removing it, then release the contactor.

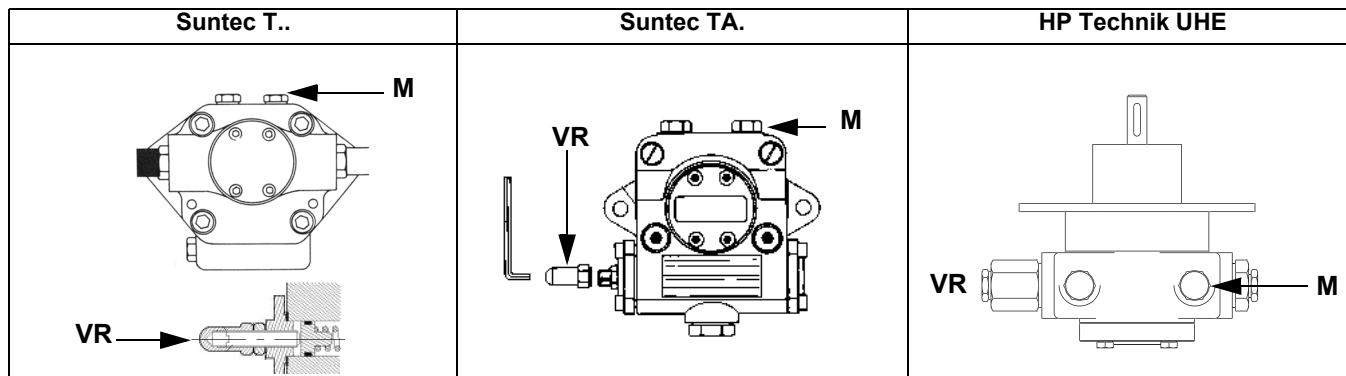

Fig. 18

- 4 Before starting the burner up, drive the high flame actuator microswitch matching the low flame one (in order to let the burner operates at the lowest output) to safely achieve the high flame stage .
- 5 Start the burner up by means of the thermostat series and wait until the pre-purge time comes to an end and that the burner starts up;
- 6 drive the burner to high flame stage, by means of the thermostat **TAB** (as far as fully-modulating burners, see the related paragraph).
- 7 Then move progressively the microswitch to higher values until it reaches the high flame position; always check the combustion values and eventually adjusting the oil pressure (see next step).

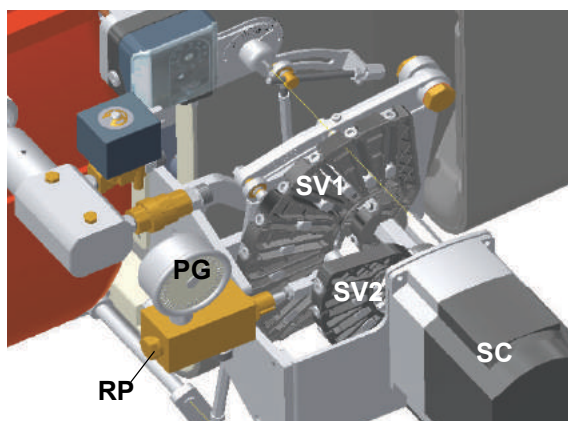

Fig. 19

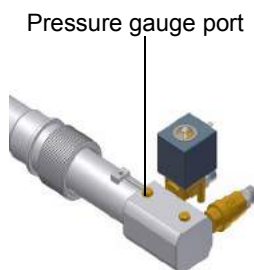

Fig. 20

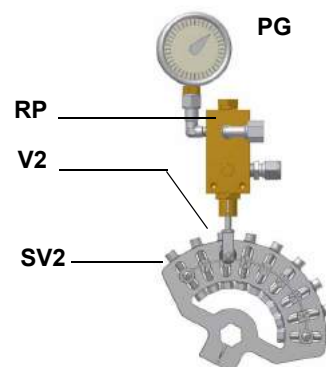

Fig. 21

- 8 Only if necessary, adjust the supply pressure as follows; insert a pressure gauge into the port shown on figure and act on on the pump adjusting screw **VR**. Pressure values are indicated at the beginning of this paragraph.
- 9 in order to get the maximum oil flow rate, adjust the pressure (reading its value on the **PG** pressure gauge) without changing the air flow rate set during the gas operation adjustments (see previous paragraph): checking always the combustion parameters, the adjustment is to be performed by means of the **SV2** adjusting cam screw (see picture) when the cam has reached the high flame position.
- 10 once the oil rate is adjusted at the maximum output (the air rate was adjusted in the gas regulation), go on with the point to point adjustment on the **SV2** (light oil side) adjusting cam as to reach the minimum output point, as described on the next steps.
- 11 as for the point-to-point regulation, move the gas low flame microswitch a little lower than the maximum position (90°);
- 12 set the **TAB** thermostat to the minimum in order that the actuator moves progressively towards the low flame position (as far as fully-modulating burners, see the related paragraph);
- 13 move the low flame cam to the minimum to move the actuator towards the low flame until the two bearings find the adjusting screw that refers to the lower position: screw **V2** to increase the rate, unscrew to decrease.
- 14 Move again cam III towards the minimum to meet the next screw on the adjusting cam and repeat the previous step; go on this way as to reach the desired low flame point.
- 15 The low flame position must never match the ignition position that is why the cam must be set 20°- 30° more than the ignition posi-

tion.

Turn the burner off; then start it up again. If the adjustment is not correct, repeat the previous steps.

Fully-modulating burners

To adjust the fully-modulating burners, use the **CMF** switch on the burner control panel (see next picture), instead of the **TAB** thermostat as described on the previous paragraphs about the progressive burners. Go on adjusting the burner as described before, paying attention to use the CMF switch instead of **TAB**.

The **CMF** position sets the operating stages: to drive the burner to the high-flame stage, set CMF=1; to drive it to the low-flame stage, set CMF=2.



- CMF = 0 stop at the current position
- CMF = 1 high flame operation
- CMF = 2 low flame operation
- CMF = 3 automatic operation

Oil pressure switch adjustment

Follow the below instruction, according to the pressure switch installed.

| | |
|--|---|
| <p style="margin-left: 20px;">A - Range (Stop pressure) B - Differential</p> <p style="margin-left: 20px;">6 mm (1/4 in.)</p> <p>NB: Remove lockplate (C) before adjustment</p> <p style="text-align: center;">Danfoss KP..</p> | <p style="text-align: center;">Trafag Picostat 9B4..</p> |
|--|---|

Maximum oil pressure switch

The oil pressure switch on the return line, checks that the pressure does not exceed a default value. This value must not be higher than the maximum acceptable pressure on the return line (this value is reported on the specification table). A pressure change on the return line could affect the combustion parameters: for this reason, the pressure switch must be set, say, at 20% over the pressure recorded during the combustion adjustment. The factory setting is 4 bar.

It is recommended to verify that the combustion parameters are within the range of acceptable values even against a pressure variation that gets close to the limit of the pressure switch.

This check should be carried out along the whole range of the burner output.

In case of unacceptable values, reduce from 20% to 15% the overpressure; later on, repeat the adjustments described above.

Minimum oil pressure switch (when provided)

The minimum oil pressure switch on the inlet line, checks that the pressure does not drop below a default value. The pressure switch must be set, say, at 10% under the pressure at the nozzle.

PART IV: MAINTENANCE

At least once a year carry out the maintenance operations listed below. In the case of seasonal servicing, it is recommended to carry out the maintenance at the end of each heating season; in the case of continuous operation the maintenance is carried out every 6 months.



WARNING: ALL OPERATIONS ON THE BURNER MUST BE CARRIED OUT WITH THE MAINS DISCONNECTED AND THE FUEL MANUAL CUTOFF VALVES CLOSED!
ATTENTION: READ CAREFULLY THE "WARNINGS" CHAPTER AT THE BEGINNING OF THIS MANUAL.

ROUTINE MAINTENANCE

- Check and clean the cartridge of the fuel filter, replace it if necessary;
- carefully check the fuel flexible hoses for leaks;
- check and clean the filter on the fuel pump: filter must be thoroughly cleaned at least once in a season to ensure correct working of the fuel unit. To remove the filter, unscrew the four screws on the cover. When reassemble, make sure that the filter is mounted with the feet toward the pump body. If the gasket between cover and pump housing should be damaged, it must be replaced;
- remove, check and clean the combustion head;
- check the ignition electrodes and their ceramic insulators, clean, adjust and replace if necessary;
- remove and clean the oil nozzles (IMPORTANT: do not clean the nozzles using metallic or sharp utensils, use only solvents or steam); at the end of maintenance operations, refit the burner, turn it on and check the combustion. If in doubt, replace the defective nozzle/s. In case of intensive use of the burner, the nozzles must be replaced at the end of the working season;
- examine and clean the detection electrode/photoelement (according to the burner models), replace it if necessary, in case of doubt, check the detection circuit, after the burner start-up;
- clean and grease levers and rotating parts.

Gas filter maintenance

To clean or remove the filter, proceed as follows:

- 1 remove the cap unscrewing the fixing screws (A);
- 2 remove the filtering cartridge (B), clean it using water and soap, blow it with compressed air (or replace it, if necessary)
- 3 replace the cartridge in its proper position taking care to place it inbetween the guides as not to hamper the cap replacement;
- 4 be sure to replace the "O" ring into its place (C) and replace the cover fastening by the proper screws (A).

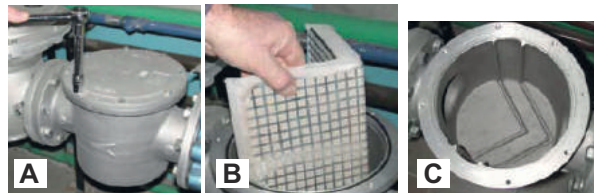

WARNING: Before opening the filter, close the manual cutoff valve downstream the filter and bleed the gas; check that inside the filter there is no pressurised gas.

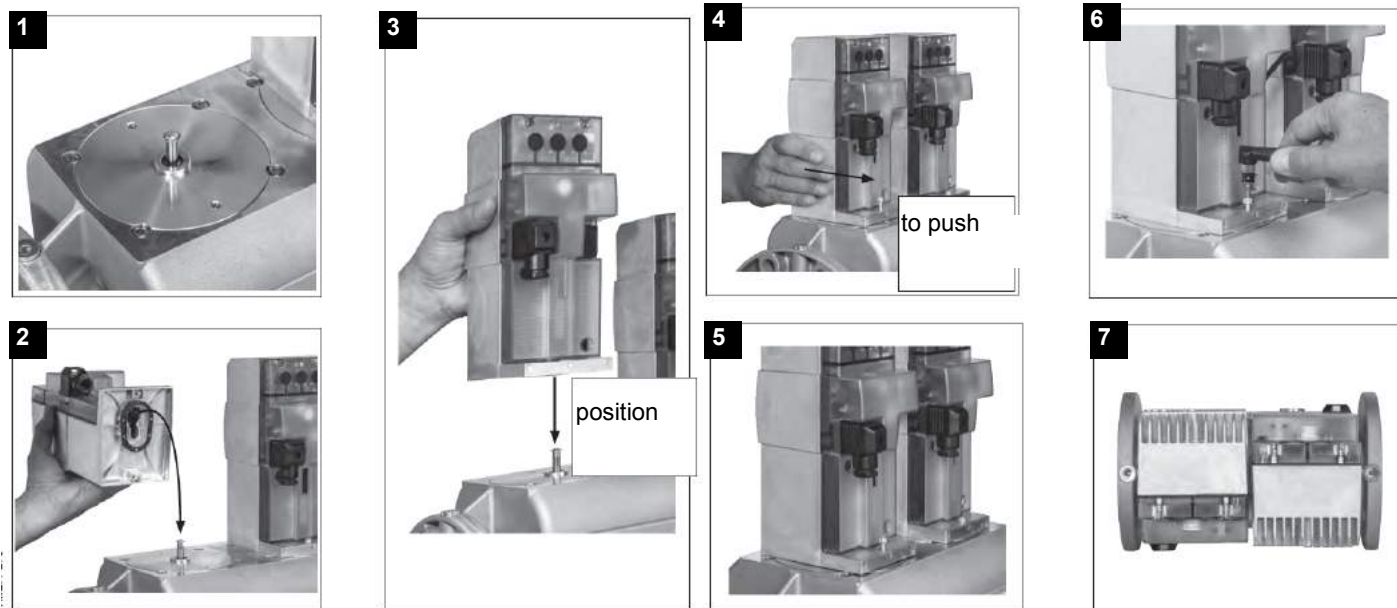
MultiBloc MBEMultiBloc VD Mounting

1. Position VD on VB, fig. 2+3.
2. Slide VD forward up to the stop, fig. 4.
3. Screw VD on with 2 M5 screws for each, max. 5 Nm/44 in.-lb., fig. 5/6.
4. VD can be mounted rotated by 180°, fig. 7.

Light oil filter maintenance

For correct and proper servicing, proceed as follows:

- 1 cutoff the required pipe section;
- 2 unscrew the filter cup;
- 3 remove the filtering cartridge, wash it with gasoline; if necessary, replace it; check the tightening O-rings and replace them if necessary;
- 4 replace the cup and restore the pipe line.

Removing the combustion head

- 1 Remove the top H.
- 2 Remove the UV detector out of its housing: disconnect electrode cables and the light oil flexible hoses.
- 3 Loosen the screws V holding the gas manifold G, loosen the connectors E.
- 4 Some models are provided with the T baffle. Move the gas manifold ahead and remove the baffle.
- 5 Pull out the complete group as shown in the picture below.
- 6 Clean the combustion head by means of a vacuum cleaner; scrape off the scale by means of a metallic brush.

Note: to replace the combustion head, reverse the operations described above.

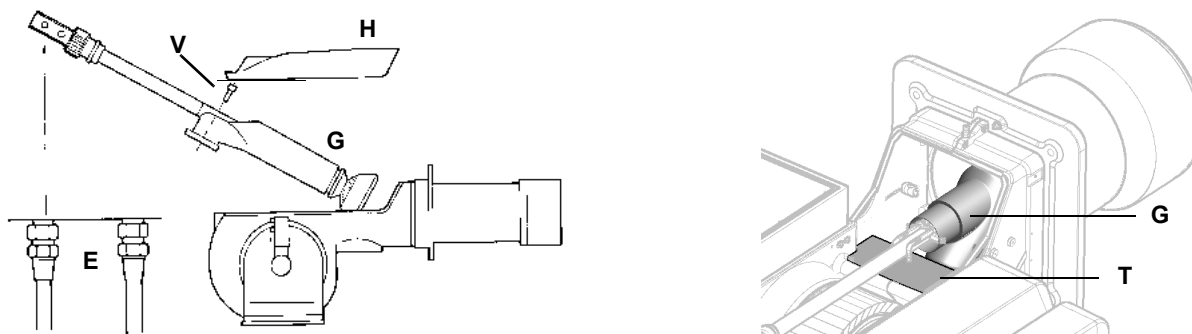

Electrodes Adjustment

Important Note: Check the ignition and detection electrodes after removing/adjusting the combustion head.



ATTENTION: avoid the ignition and detection electrodes to contact metallic parts (blast tube, head, etc.), otherwise the boiler's operation would be compromised. Check the electrodes position after any intervention on the combustion head.

Adjust the electrodes position, according to the quotes shown othe next picture

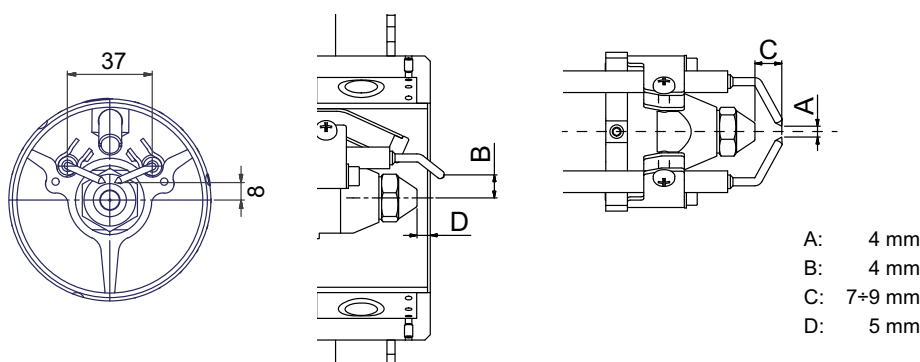

Cleaning/replacing the electrodes



ATTENTION: avoid the electrodes to get in touch with metallic parts (blast tube, head, etc.), otherwise the boiler operation would be compromised. Check the electrodes position after any intervention on the combustion head.

To remove the oil gun, proceed as follows:

- 1 remove the combustion head as described on the prevoius paragrah;
- 2 loosen the **VL** screw and remove the oil gun and the electrodes: check the oil gun, replace it if necessary;
- 3 after removing the oil gun, unscrew the nozzle and replace it if necessary;
- 4 in order to replace the electrodes, unscrew the **VE** fixing screws and remove them: place the new electrodes being careful to observe the measures showed on pag.: reasemble following the reversed procedure.

Caution: adjust the nozzle position according to the air pipe, by means of the **VU** screw, ance the **VL** screw is fastened.

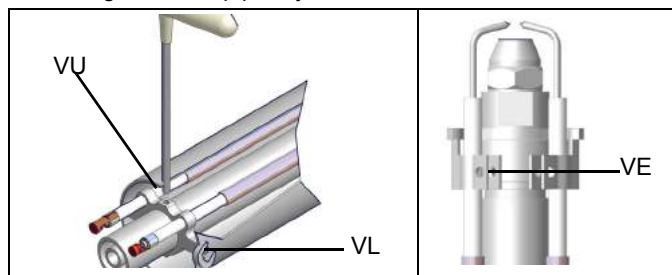

Checking the detection current

To check the detection signal follow the scheme in the picture below. If the signal is less than the value indicated, check the position of the detection electrode or detector, the electrical contacts and, if necessary, replace the electrode or the detector.

| | |
|-----------------|-------------------------------|
| Control box | Minimum detection signal |
| Siemens LME7... | 70 μ A (with UV detector) |

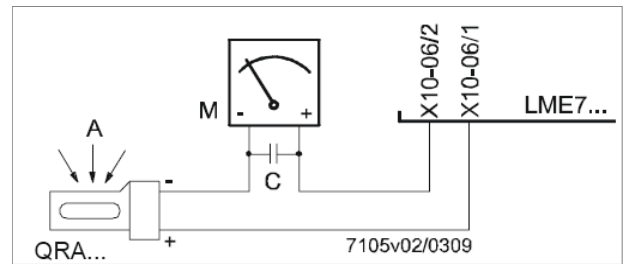

Fig. 22: Detection by photocell QRA..

Flame detection probe

To clean/replace the detection photocell, proceed as follows:

- 1 Disconnect the system from the electrical power supply.
- 2 Shut off the fuel supply;
- 3 remove the photocell from its slot (see next figure);
- 4 clean the bulbe if dirty, taking care not to touch it with bare hands;
- 5 if necessary, replace the bulb;
- 6 replace the photocell into its slot.



Burner service term

- In optimal operating conditions, and with preventive maintenance, the burner can last up to 20 years.
- Upon expiry of the burner service term, it is necessary to carry out a technical diagnosis and, if necessary, an overall repair.
- The burner status is considered to be at its limit if it is technically impossible to continue using it due to non-compliance with safety requirements or a decrease in performance.
- The owner makes the decision whether to finish using the burner, or replacing and disposing of it based on the actual state of the appliance and any repair costs.
- The use of the burner for other purposes after the expiry of the terms of use is strictly prohibited.

Seasonal stop

To stop the burner in the seasonal stop, proceed as follows:

- 1 turn the burner main switch to 0 (Off position)
- 2 disconnect the power mains
- 3 close the fuel valve of the supply line

Burner disposal

In case of disposal, follow the instructions according to the laws in force in your country about the "Disposal of materials".

WIRING DIAGRAMS

Refer to the attached wiring diagrams.

WARNING

- 1 - Electrical supply 230V / 400V 50Hz 3N a.c.
- 2 - Do not reverse phase with neutral
- 3 - Ensure burner is properly earthed

TROUBLESHOOTING GUIDE - Gas operation

| | | |
|---|--|--|
| BURNER DOESN'T LIGHT | * No electric power supply | * Wait until power supply is back |
| | * Main switch open | * Close the switch |
| | * Thermostats open | * Check set points and thermostat connections |
| | * Bad thermostat set point or broken thermostat | * Set or replace the thermostat |
| | * No gas pressure | * Restore gas pressure |
| | * Safety devices (manually operated safety thermostat or pressure switch and so on) open | * Restore safety devices; wait that boiler reaches its temperature then check safety device functionality. |
| | * Broken fuses | * Replace fuses. Check current absorption |
| | * Fan thermal contacts open (only three phases) | * Reset contacts and check current absorption |
| | * Burner control locked out | * Reset and check its functionality |
| | * Burner control damaged | * Replace burner control |
| GAS LEAKAGE: BURNER LOCKS OUT (NO FLAME) | * Gas flow too low | * Increase the gas flow * Check gas filter cleanness * Check butterfly valve opening when burner is starting (only Hi-Low flame and progressive) |
| | * Ignition electrodes discharge to ground because dirty or broken | * Clean or replace electrodes |
| | * Bad electrodes setting | * Check electrodes position referring to instruction manual |
| | * Electrical ignition cables damaged | * Replace cables |
| | * Bad position of cables in the ignition transformer or into the electrodes | * Improve the installation |
| | * Ignition transformer damaged | * Replace the transformer |
| BURNER LOCKS OUT WITH FLAME PRESENCE | * Bad flame detector set | |
| | * Flame detector damaged | * Replace or adjust flame detector |
| | * Bad cables of flame detector | * Check cables |
| | * Burner control damaged | * Replace burner control |
| | * Phase and neutral inverted | * Adjust connections |
| | * Ground missing or damaged | * Check ground continuity |
| | * Voltage on neutral | * Take off tension on neutral |
| | * Too small flame (due to not much gas) | * Adjust gas flow * Check gas filter cleanness |
| * Too much combustion air | * Adjust air flow rate | |
| only FOR LME22: BURNER CONTINUES TO PERFORM ALL ITS FEATURES WITHOUT IGNITING THE BURNER | * Air pressure switch damaged or bad links | * Check air pressure switch functions and links |
| | * Burner control damaged | * Replace burner control |
| BURNER LOCKS OUT WITHOUT ANY GAS FLOW | * Gas valves don't open | * Check voltage on valves; if necessary replace valve or the burner control * Check if the gas pressure is so high that the valve cannot open |
| | * Gas valves completely closed | * Open valves |
| | * Pressure governor too closed | * Adjust the pressure governor |
| | * Butterfly valve too closed | * Open the butterfly valve |
| | * Maximum pressure switch (if installed) open. | * Check connection and functionality |
| | * Air pressure switch doesn't close the NO contact | * Check connections * Check pressure switch functionality |
| THE BURNER IS BLOCKED AND THE EQUIPMENT PROVIDES A LOCK CODE "CAUSE AIR PRESSURE SWITCH FAULT" | * Air pressure switch damaged (it keeps the stand-by position or badly set) | * Check air pressure switch functionality * Reset air pressure switch |
| | * Air pressure switch connections wrong | * Check connections |
| | * Air fan damaged | * Replace motor |
| | * No power supply | * Reset power supply |
| | * Air damper too closed | * Adjust air damper position |
| BURNER LOCKS OUT DURING NORMAL RUNNING | * Flame detector circuit interrupted | * Check wiring * Check photocell |
| | * Burner control damaged | * Replace burner control |
| | * Maximum gas pressure switch damaged or badly set | * Reset pressure switch or replace it |
| THE BURNER STARTS AND AFTER A WHILE IT REPEATS THE STARTING CYCLE. | * Gas pressure switch badly set | * Reset the pressure switch |
| | * Gas filter dirty | * Clean gas filter |
| | * Gas governor too low or damaged | * Reset or replace the governor |
| BURNER STANDS WHILE RUNNING WITHOUT ANY SWITCHING OF THERMOSTATS | * Thermal contacts of fan motor open | * Reset contacts and check values * Check current absorption |
| FAN MOTOR DOESN'T START | * Internal motor wiring broken | * Replace wiring or complete motor |
| | * Fan motor starter broken | * Replace starter |
| | * Fuses broken (three phases only) | * Replace fuses and check current absorption |
| BURNER DOESN'T SWITCH TO HIGH FLAME | * Hi-low flame thermostat badly set or damaged | * Reset or replace thermostat |
| | * Servomotor cam badly set | * Reset servomotor cam |
| mechanical only: SOMETIMES THE SERVOMOTOR RUNS IN THE WRONG WAY | * Servomotor capacitor damaged | * Replace capacitor |

TROUBLESHOOTING GUIDE - Light oil operation

| | | |
|--|---|--|
| BURNER DOESN'T LIGHT | * No electric power supply | * Wait for electric power supply is back |
| | * Main switch open | * Close the switch |
| | * Thermostats open | * Check set points and thermostat connections |
| | * Bad thermostat set point or broken thermostat | * Set or replace the thermostat |
| | * No gas pressure | * Restore gas pressure |
| | * Safety devices (manually operated safety thermostat or pressure switch, and so on ...) open | * Restore safety devices; wait that boiler reaches its temperature then check safety device functionality. |
| | * Broken fuses | * Replace fuses. Check current absorption |
| | * Fan thermal contacts open (only three phases) | * Reset contacts and check current absorption |
| | * Burner control locked out | * Reset and check its functionality |
| | * Burner control damaged | * Replace burner control |
| BURNER LOCKS OUT WITH FLAME PRESENCE | * Flame detector dirty or damaged | * Clean or replace flame detector |
| | * Burner control damaged | * Replace burner control |
| | * Smoking flame | * Reset combustion air flow rate |
| | | * Check the nozzle and, if necessary, replace it |
| | | * Check cleanliness of combustion head |
| BURNER LOCKS OUT WITHOUT ANY FUEL FLOW RATE | * Check chimney suction | * Check boiler cleanliness |
| | * Combustion head dirty | * Clean combustion head |
| | * No fuel | * Fill the tank |
| | * Pump joint broken | * Check pump pressure |
| | * Pump damaged | * Check pump suction |
| | | * Replace pump |
| | * Compressed air (or steam) too high | * Released compressed air (or steam) pressure |
| | * Oil metering valve not open far enough | * Check air pressure |
| | | * Check servomotor position |
| | | * Check wiring path or replace valve |
| BURNER LOCKS OUT WITH FUEL FLOW RATE (NO FLAME) | * Oil valve not energized | * Adjust or replace the motor |
| | * Fan motor not efficient | * Change rotation |
| | * Fan or pump motor runs in the wrong way | * Clean or replace the nozzle |
| | * Obstructed nozzle | * Clean or replace the valve |
| | * Check valve in the tank locked or leaking | * Clean filter |
| | * Oil filter dirty | |
| | * Pump filter dirty | * Clean or replace solenoid valve |
| | * Solenoid valve dirty or broken | |
| | * Oil pressure too low | * Reset oil pressure |
| | * Nozzle dirty or damaged | * Clean or replace nozzle |
| PUMP TOO NOISY | * Water in the tank | * Take off all the water from the tank |
| | | * Clean all filters |
| | * Suction too high | * Check suction before pump. If necessary clean filters. |
| | * Ignition electrodes grounded because dirty or damaged | * Clean or replace electrodes |
| | * Ignition electrodes badly set | * Check electrodes position referring to instruction manual |
| | * Cables damaged | * Replace cables |
| | * Bad position of cables in the ignition transformer or into the electrodes | * Improve the installation |
| * Ignition transformer damaged | * Replace the transformer | |
| BURNER RUMBLES WHEN MODULATING TO HIGH FIRE | * Suction too high (over 0,35 bar) (dirty filters, check valve in the tank locked, and so on ...) | * Clean filters |
| | * Flexible hoses damaged | * Replace check valve in the tank |
| | * Air infiltration in the pipes | * Replace flexible hoses |
| | * Pipe too long or too narrow | * Take off all infiltration |
| CARBON BUILD-UP ON THE FIRESIDES OF THE BOILER | | * Increase line size |
| | * Burner is too lean | * Adjust air-oil ratio |
| | * Drawer assembly not set properly | * Check drawer position |
| FLAME IRREGULAR OR SPARKING | * Oil may be too hot | * Check oil temperature |
| | * Flame is blowing off head | * Check head position |
| | * Oil flame not retaining to head | |
| | * Dirty nozzle | * Clean the nozzle |
| | * Oil spray impinging on burner head | * Check position of the nozzle respect to the head |
| BURNER LIGHTS BUT FLAME DOESN'T RETAIN TO BURNER HEAD | * Spray angle of the nozzle too wide | * Reduce spray angle |
| | * Oil pressure at nozzle too low | * Reset oil pressure |
| | * Air flow rate too high | * Adjust air flow rate |
| | * Oil is too cold | * Adjust oil temperature |
| | * Dirt in the oil | * Check filters |
| | * Water in the fuel | * Take off all the water |
| | * Oil impingement on the combustion head | * Drawer assembly far too rear |
| | * Nozzle dirty or damaged | * Nozzle is not protruding through centerhole of air diffuser |
| FLAME IRREGULAR OR SMOKING | | * Oil flame not retaining to the head |
| | | * Clean or, if necessary, replace the nozzle |
| | * Drawer assembly not positioned correctly | * Move forward or backward |
| | * Nozzle too far forward through centerhole of diffuser | * Move nozzle backward respect to diffuser |
| | * Oil or air pressure at nozzle is too low | * Increase oil or air pressure |
| FUEL GAS TEMPERATURE TOO HIGH | * Air louver too open | * Reduce air louver opening |
| | * Too much spread between oil and air (or steam) pressure | * Set the spread to a proper value |
| | * Not enough combustion air | * Adjust air flow rate |
| | * Nozzle dirty or damaged | * Clean or, if necessary, replace the nozzle |
| | * Flame is too big for furnace or nozzle spray angle is wrong | * Check burner-furnace coupling |
| | | * Change nozzle with a suitable one |
| | * Nozzle spray angle wrong (flame too long or too wide) | * Replace nozzle |
| | * Boiler dirty | * Clean the boiler |
| | * Not enough suction at chimney | * Check chimney cleanliness or size |
| | * Pressure at nozzle too low | * Reset oil pressure |
| * Oil too cold | * Reset oil temperature | |
| * Combustion air inlet dirty | * Clean the air inlet | |
| * Flame is too small respect to furnace volume | * Replace nozzle or reset pump pressure | |
| FUEL GAS TEMPERATURE TOO HIGH | * Boiler dirty | * Clean the boiler |
| | * Oil flow rate too high | * Adjust oil pressure or replace nozzle |



C.I.B. UNIGAS S.p.A.
Via L.Galvani, 9 - 35011 Campodarsego (PD) - ITALY
Tel. +39 049 9200944 - Fax +39 049 9200945/9201269
web site: www.cibunigas.it - e-mail: cibunigas@cibunigas.it

Note: specifications and data subject to change. Errors and omissions excepted.

LME73.000Ax + PME73.831AxBC LME73.831AxBC



Service instruction manual

M12921CB Rel.1.2 02/2016

GENERAL FEATURES

LME/ is suitable for gas, light and heavy oil burners

LME7 series has two devices: LME73.000 (hardware) and PME73.831AxBC (programmable unit). The LME73.831AxBC is also available: it has a built in software and it is not programmable.

LME7 is inside the control panel. If supplied, PME73.831BC is inside the LME7;

The display AZL23.. or AZL21.. is available for Service and hardware setup.

LME7... are used for the startup and supervision of 2-stage/progressive, modulating forced draft gas burners in intermittent operation.

The flame is supervised with an ionization probe, optionally with UV flame detector QRA2..., QRA4.U or QRA10....

Integrated in the LME7... basic unit are:

- Burner control
- BCI
- Control for one actuator
- Lockout reset button (info button)
- 3 multicolor signal lamp LED for operations and fault notifications
- 3 x 7-segment display for service, fault and operating state information
- Interface for program module (no function)

Passwords protect the different parameter levels against unauthorized access. Basic settings that the plant operator can make on site require no password.

Functions:



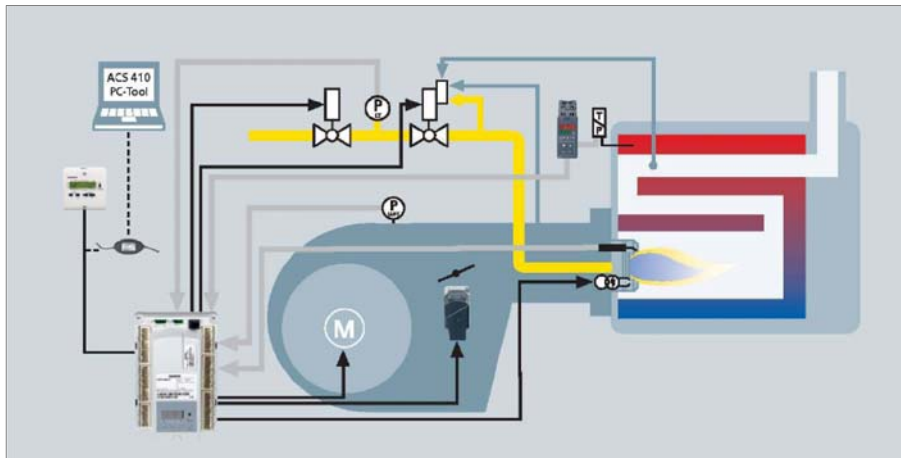

- Undervoltage detection
- Electrical remote reset facility
- Accurate control times thanks to digital signal handling
- Multicolor indication of fault status and operating state messages
- Air pressure supervision with function check of air pressure switch during start and operation (gas)
- Repetition limitation
- Controlled intermittent operation after 24 hours of continuous operation*
- BCI
- Indication of program sequence

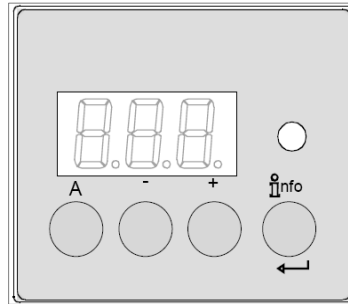

* after no more than 24 hours of continuous operation, the burner control initiates automatic controlled shutdown followed by a restart.

User interface :



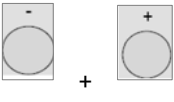

| | |
|---|--|
|  | <p>Button A</p> <ul style="list-style-type: none"> - Display preset output - In lockout position: Power value to the time of fault |
|  | <p>Info and Enter button</p> <ul style="list-style-type: none"> - Reset in the event of fault, changeover visual diagnostic of the cause of fault (refer to chapter Diagnostics of cause of fault) |
|  | <p>- button</p> <ul style="list-style-type: none"> - Display flame signal current 2 or phases display - In lockout position: MMI phase to the time of fault |
|  | <p>+ button</p> <ul style="list-style-type: none"> - Display flame signal current 1 or phases display - In lockout position: MMI phase to the time of fault |
|  | <p>3 multicolor signal lamp</p> <ul style="list-style-type: none"> - Refer to chapter "Blink code table" |
|  | <p>+ and - button: Escape function (press + and - simultaneously)</p> <ul style="list-style-type: none"> - No adoption of value - One menu level up - Keep depressed for >1second for backup / restore function |

First startup when PME is supplied or PME replacement:

First startup:

- 1) insert a new PME
- 2) turn the power on; The display shows "rst" and "PrC" one after the other.

- 3) keep pushing the INFO  button more than 3 seconds; "run" appears; PME parameters will be transferred to LME
- 4) at the end, "End" and "rst" appears one after the other; Later (2'), the control box locks out "Loc 138"

- 5) reset the control box by pressing the INFO  button (for less than 3 seconds)
- Now the display shows "OFF"; the burner is ready to be started.



Replacement:

- 1) Turn off the burner, replace the existing PME with a new one
- 2) For the first startup, repeat the above procedure, from step 2.

List of phase display on board LME :

| Phase number of 7-segment display | LED | Function |
|--|-----------------------|--|
| Standby | | |
| OFF | Off | Standby, waiting for heat demand |
| P08 | Off | Mains ON / test phase (e.g. detector test) |
| Startup | | |
| P21 | Yellow | Safety valve ON, air pressure switch test / POC test (timeout / locking |
| P22 | Yellow | Fan motor ON / air pressure switch test / settling time |
| P24 | Yellow | Actuator opens in prepurging position |
| P30 | Yellow | Prepurging |
| P36 | Yellow | Actuator closes in ignition load / low-fire position |
| P38 | Yellow blinking | Preignition time |
| P40 | Yellow blinking | 1st safety time (TSA1) / ignition transformer ON |
| P42 | Green | Safety time (ignition transformer OFF), flame check |
| P44 | Green | Interval: End of safety time and fuel valve 1 (V1) ON Interval: End of safety time and load controller (LR) release |
| P50 Green | P50 Green | 2nd safety time (TSA2) |
| P54 Green | P54 Green | P259.01: Actuator opens in > low-fire |
| P54 Green | P54 Green | P260: Actuator closes in low-fire |
| oP1 Green | oP1 Green | Interval until release of load controller target (analog or 3-position step input) |
| Operation | | |
| oP | Green | Operation, modulating operation |
| Shutdown | | |
| P10 | Yellow | Shutdown, actuator opens in CLOSE position (home run) |
| P72 | Yellow | Actuator opens in high-fire position / end of operation |
| P74 | Yellow | Postpurging |
| Valve proving | | |
| P80 | Yellow | Test space evacuating |
| P81 | Yellow | Checking time fuel valve 1 |
| P82 | Yellow | Test space filling |
| P83 | Yellow | Checking time fuel valve 2 |
| Waiting phases (start prevention) | | |
| P01 | Red / yellow blinking | Undervoltage |
| P02 | Yellow | Safety loop open |
| P04 | Red / green blinking | Extraneous light on burner startup (timeout / locking after 30 s) |
| P90 | Yellow | Pressure switch-min open |
| Lockout | | |
| LOC | Red | Lockout phase |

Operation :

| | |
|---|---|
|  | <p>The lockout reset button (info button) (EK) is the key operating element for resetting the burner control and for activating / deactivating the diagnostics functions.</p> |
|  | <p>The multicolor signal lamp (LED) is the key indicating element for visual diagnostics.</p> |

Both lockout reset button (EK) and signal lamp (LED) are located in the control panel.

There are 2 diagnostics choices:

1. Visual diagnostics: Indication of operating state or diagnostics of cause of fault
2. Diagnostics: Via internal display or to AZL2.. display and operating unit

Visual diagnostics:

In normal operation, the different operating states are indicated in the form of color codes according to the color code table given below.

Color code table for multicolor signal lamp (LED) :

| State | Color code | Color |
|---|----------------|-------------------|
| Waiting time (tw), other waiting states | ○..... | OFF |
| Ignition phase, ignition controlled | ●○●○●○●○●○●○●○ | Blinking yellow |
| Operation, flame o.k. | □..... | Green |
| Operation, flame not o.k. | □○□○□○□○□○□○□○ | Blinking green |
| Extraneous light on burner startup | □▲□▲□▲□▲□▲□▲ | Green-red |
| Undervoltage | ●▲●▲●▲●▲●▲●▲ | Yellow-red |
| Fault, alarm | ▲..... | Red |
| Error code output (refer to «Error code table») | ▲○▲○▲○▲○▲○▲○ | Blinking red |
| Interface diagnostics | ▲▲▲▲▲▲▲▲▲▲▲▲ | Red flicker light |
| Heating request | ●..... | Yellow |
| Heating request | ●●▲●●▲●●▲●●▲ | Yellow |

Key

| | |
|-------|------------|
| | Steady on |
| ○ | Led off |
| ▲ | Led red |
| ● | Led yellow |
| □ | Led green |

Program sequence :

Version 1:

- Ignition load < low-fire
- Prepurging in high-fire
- Parameter 515 = 1 (condition parameter 259.01 > 0 seconds)

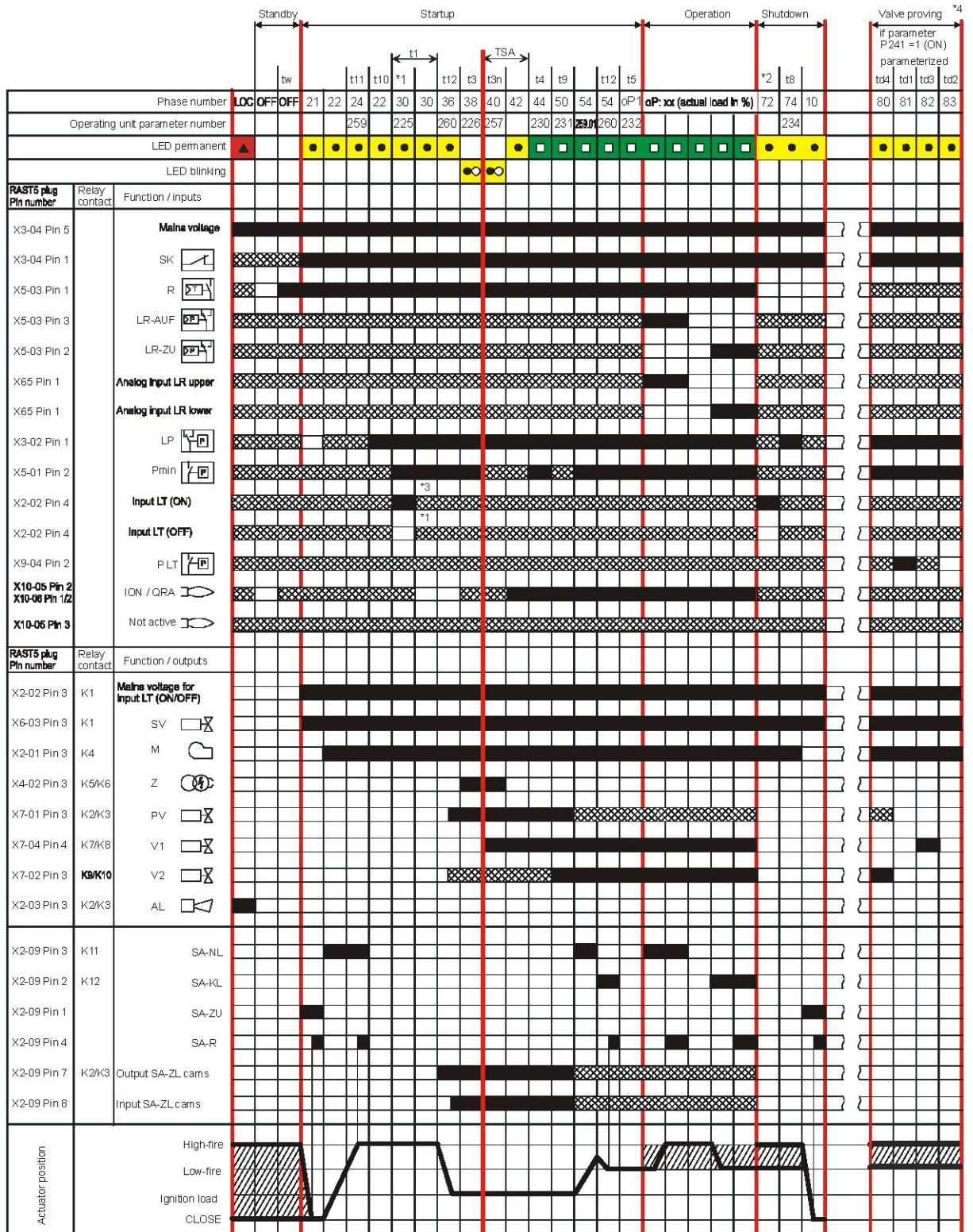

Program sequence :

Version 2:

- Ignition load > low-fire
- Prepurging in high-fire
- Parameter 515 = 1 (condition parameter 259.01 = 0 seconds)

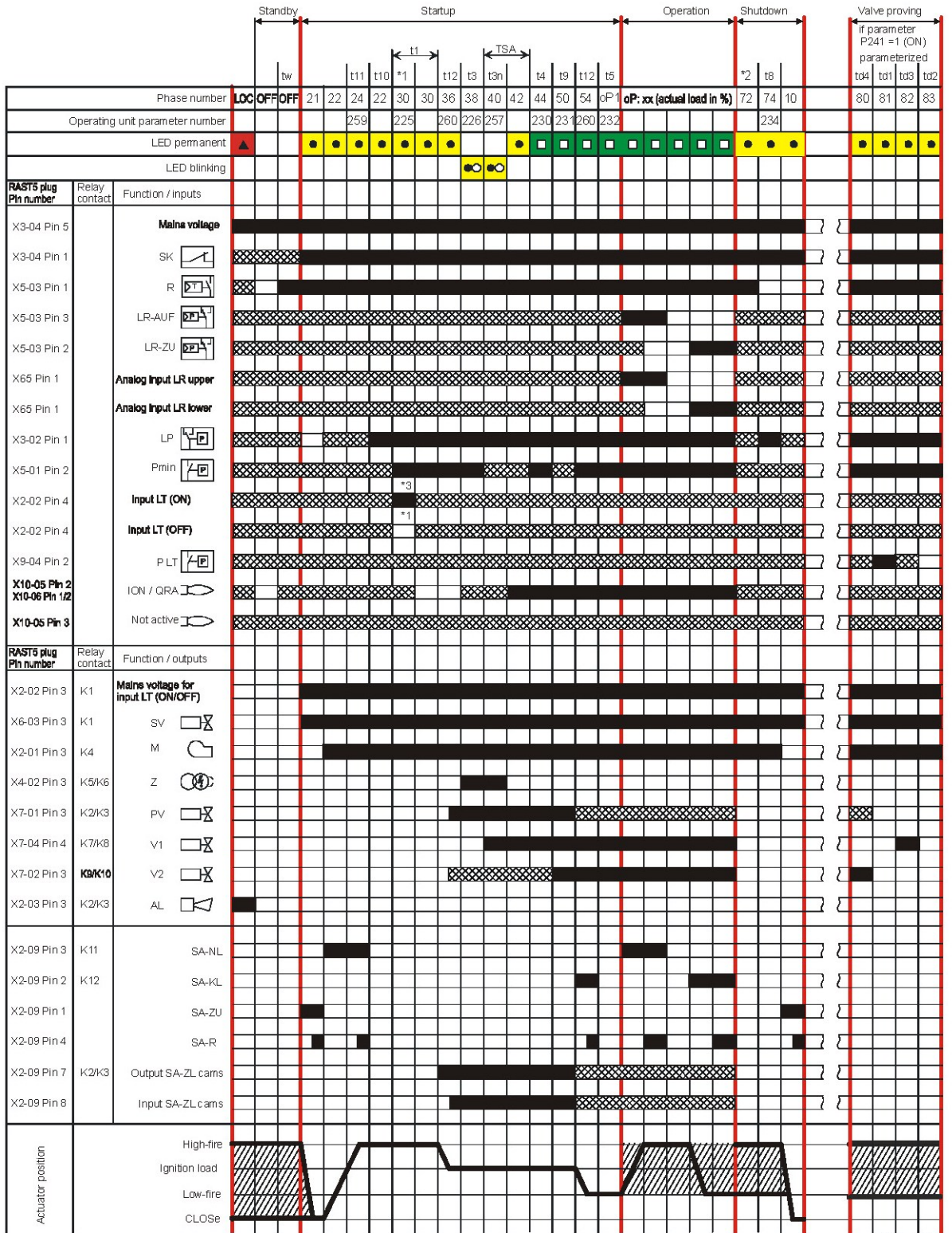

7114d04e/0112

| Phase number | Function |
|--------------|--|
| LOC | Lockout phase |
| OFF | Standby, waiting for heat demand |
| oP | Operation, modulating operation |
| oP1 | Interval until release of load controller target (analog or 3-position step input) |
| 01 | Under voltage |
| 02 | Safety loop open |
| 04 | Extraneous light on burner startup (timeout/locking after 30 seconds) |
| 08 | Mains ON/test phase (e.g. detector test) |
| 10 | Shutdown, actuator opens in CLOSE position (homerun) |
| 21 | Safety valve ON, air pressure switch OFF, actuator opens in CLOSE position |
| 22 | Part 1: Fan motor ON |
| | Part 2: Specified time (t10) air pressure switch (LP) |
| | Message (timeout) stabilization air pressure switch |
| 24 | Actuator opens in prepurge position |
| 30 | Part 1: Prepurge time (t1) without extraneous light test |
| | Valve proving after mains ON, lockout |
| | Part 2: Prepurge time (t1) with extraneous light test |
| 36 | Actuator closes in ignition load |
| 38 | Preignition (t3) |
| 40 | Postignition time (t3n), parameter 257 + 0.3 seconds |
| 42 | Flame detection |
| 44 | Interval (t4): End of safety time (TSA) and burner valve 2 ON |
| 50 | 2nd safety time (t9) |
| 54 | Parameter 259.01: Actuator opens in > low-fire |
| | Parameter 260: Actuator closes in low-fire |
| 72 | End of operation, checking if valve proving (LT) shall be performed |
| 74 | Postpurging (t8) |
| 80 | Test space evacuation (td4) |
| 81 | Test time (td1) fuel valve 1 (V1) |
| 82 | Test space filling (td3) |
| 83 | Test time (td2) fuel valve 2 (V2) |
| 90 | Pressure switch-min open <input type="checkbox"/> safety shutdown |
| *1 | Valve proving is conducted when... |
| | - parameter 241.00 = 1 and parameter 241.02 = 1, or |
| | - parameter 241.00 = 1 and parameter 241.01 = 0 |
| *2 | Valve proving is conducted when... |
| | - parameter 241.00 = 1 and parameter 241.02 = 1, or |
| | - parameter 241.00 = 1 and parameter 241.01 = 1 |
| *3 | Valve proving (LT) will not be performed |

Error code table :

| Red blink code of fault signal lamp (LED) | Possible cause |
|--|--|
| 2 x blinks | No establishment of flame at the end of the safety time (TSA) |
| | <ul style="list-style-type: none"> - Faulty or soiled flame detector - Faulty or soiled fuel valves - Poor adjustment of burner, no fuel - Faulty ignition equipment |
| 3 x blinks | Air pressure switch (LP) faulty <ul style="list-style-type: none"> - Loss of air pressure after specified time (t10) - Air pressure switch (LP) welded in no-load position |
| 4 x blinks | Extraneous light on burner startup |
| 5 x blinks | Time supervision air pressure switch (LP) <ul style="list-style-type: none"> - Air pressure switch (LP) welded in working position |
| 6 x blinks | Actuator position not reached <ul style="list-style-type: none"> - Actuator faulty - Wrong adjustment of cam - Actuator defective or blocked - False connection - Misadjustment |
| 7 x blinks | Too many losses of flame during operation (limitation of repetitions) <ul style="list-style-type: none"> - Faulty or soiled flame detector - Faulty or soiled fuel valves - Poor adjustment of burner |
| 8 x blinks | Free |
| 9 x blinks | Free |
| 10 x blinks | Wiring error or internal error, output contacts, other faults |
| 12 x blinks | Valve proving (LT) <ul style="list-style-type: none"> - Fuel valve 1 (V1) leaking |
| 13 x blinks | Valve proving (LT) <ul style="list-style-type: none"> - Fuel valve 2 (V2) leaking |
| 14 x blinks | Error in connection with valve closure control POC |
| 15 x blinks | Error code ≥ 15 Error code 22: Error of safety loop (SL) |

During the time the cause of fault is diagnosed, the control outputs are deactivated:

- Burner remains shut down
- External fault indication (AL) at terminal X2-03, pin 3 steady on

Diagnostics of cause of fault is quit and the burner switched on again by resetting the burner control. Press the lockout reset button (info button) for about 1 second (<3 seconds).

Flame detection – detection electrode :

| | |
|--|--|
| Short-circuit current | Max. AC 1 mA |
| Required detector current | Min. DC 2 μ A, display approx. 45 % |
| Possible detector current | Max. DC 3 μ A, display approx. 100 % |
| Permissible length of detector cable (laid separately) | 30 m (core-earth 100 pF/m) |

Measuring circuit

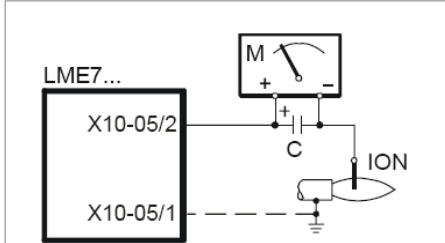

Keys

- C - Electrolytic condenser 100...470 μ F; DC 10...25 V
- ION - Ionization probe
- M - Microammeter Ri max. 5,000 Ω

Flame detection – UV probe :

Threshold values when flame is supervised by QRA...

| | |
|---|--|
| - Start prevention (extraneous light) | Intensity (parameter 954) approx. 12 % |
| - Operation | Intensity (Parameter 954) approx. 13 % |
| Operating voltage | AC 280 V \pm 15 % |
| Mains frequency | 50...60 Hz \pm 6 % |
| Required detector current | Min. 70 μ A |
| Possible detector current | |
| - Operation | Max. 700 μ A |
| Perm. length of detector cable | |
| - Normal cable, laid separately ¹⁾ | Max. 100 m |

¹⁾ Multicore cable not permitted

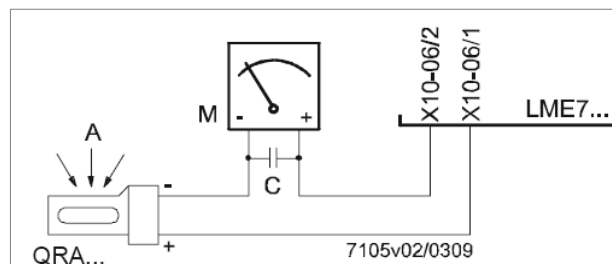

Keys

- A - Exposure to light
- C - Electrolytic condenser 100...470 μ F; DC 10...25 V
- M - Microammeter Ri max. 5,000 Ω

Warning!

Input QRA... is not short-circuit-proof!
 Short-circuits of X10-06/2 against earth can destroy the QRA... input
 Simultaneous operation of flame detector QRA... and detection electrode is not permitted
 To make certain the age of the UV tube can be determined, the LME7... basic unit must always be connected to mains supply.

Gas proving system :

Valve proving is dependent on input valve proving ON / OFF (X2-02). When a leak is detected, the gas valve proving function ensures that the gas valves will not be opened and that ignition will not be switched on. Lockout will be initiated.

Valve proving with separate pressure switch (P LT)

Step 1: td4 – Evacuation of test space

Gas valve on the burner side is opened to bring the test space to atmospheric pressure.

Step 2: td1 – Test atmospheric pressure

When the gas has closed, the gas pressure in the test space must not exceed a certain level.

Step 3: td3 Filling of test space

Gas valve on the mains side opens to fill the test space.

Step 4: td2 – Test gas pressure

When the gas valve has closed, the gas pressure in the test space must not drop below a certain level.

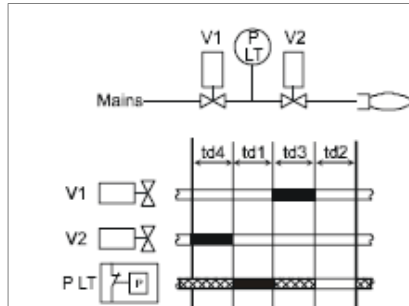

Controllo tenuta con pressostati separati

Keys

td1 Test atmospheric pressure

td2 Test gas pressure

td3 Filling of test space

td4 Evacuation of test space

V... Fuel valve

PLT Pressure switch valve proving

■ Input / output signal 1 (ON)

□ Input / output signal 0 (OFF)

▨ Input permissible signal 1 (ON) or 0 (OFF)



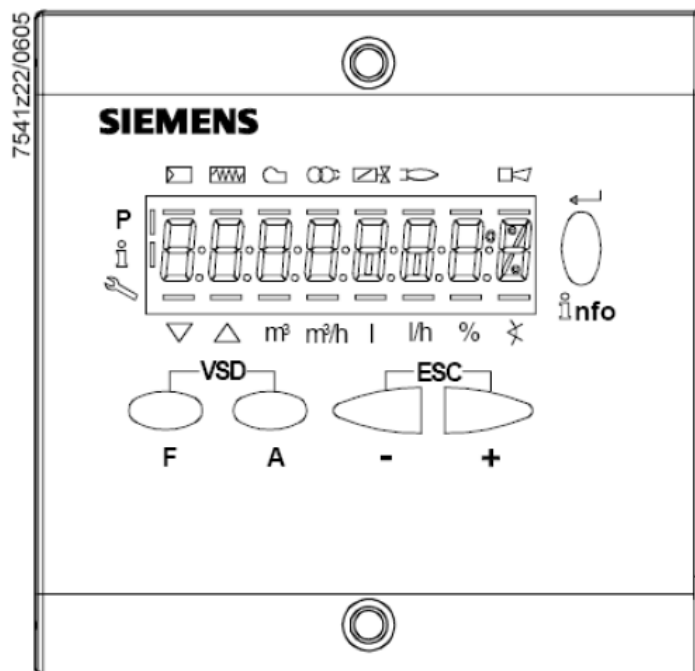

| No. | Parameter |
|-----|--|
| 242 | Valve proving evacuation of test space |
| 243 | Valve proving time test atmospheric pressure |
| 244 | Valve proving filling of test space |
| 245 | Valve proving time test gas pressure |

Instruction, control and modify via AZL2x :

The AZL2x.. display/programming unit is shown below:

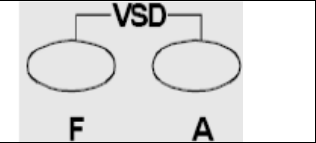

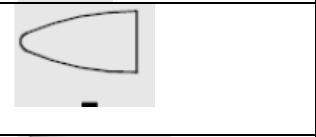
The keys functions are the following:

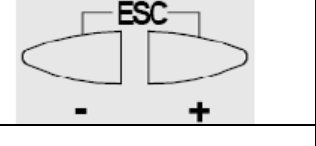
| | |
|--|---|
|  | <p>Key F + A While pressing the two keys contemporarily, the code message will appear: by entering the proper password it is possible to access the Service mode.</p> |
|  | <p>Info and Enter keys Used for Info and Service menus Used as Enter key in the setting modes Used as Reset key in the burner operation mode Used to enter a lower level menu</p> |
|  | <p>Key - Used for one menu level down Used to decrease a value</p> |
|  | <p>Key + Used for one menu level up Used to increase a value</p> |
|  | <p>Keys (+ & -)= ESC By pressing + and - at the same time, the ESCAPE function is performed No adoption of value One menu level down</p> |

The display will show these data:

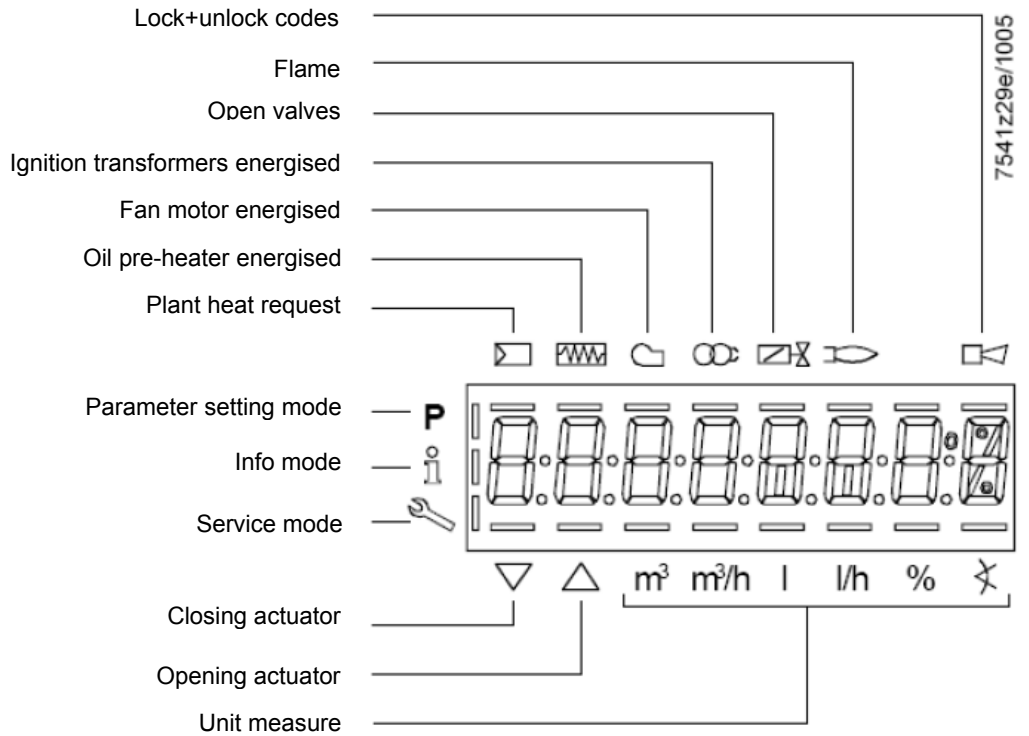

While pushing the  button together with whatever else button, LME73 locks out; the display shows



On stand-by position,  appears

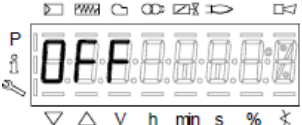

On operation, all the phases appears with their number.



List of phase with display AZL2x :

| Phase number | Function |
|--|--|
| Standby | |
| OFF | Standby, waiting for heat request |
| Ph08 | Power ON / test phase (e.g. detector test) |
| Startup | |
| Ph21 | Safety valve ON, air pressure switch test / POC test (timeout / locking after 5 seconds), actuator opens in low-fire position / CLOSE position |
| Ph22 | Fan motor ON or air pressure switch test / settling time |
| Ph24 | Actuator travels to the prepurge position |
| Ph30 | Prepurging |
| Ph36 | Actuator closes until ignition load / low-fire is reached, and parameter 259.02: Actuator opens to a position > ignition load |
| Ph38 | Preignition |
| Ph40 | 1st safety time (TSA1) / ignition transformer ON |
| Ph42 | Safety time (ignition transformer OFF), flame check |
| Ph44 | Interval: End of safety time and fuel valve 1 (V1) ON |
| Ph50 | 2nd safety time (TSA2) |
| Ph54 | P259.01: Actuator opens in > low-fire |
| Ph54 | P260: Actuator closes in low-fire |
| oP1 | Interval until release of load controller target (analog or 3-position step input) |
| Operation | |
| oP | Operation, modulating operation |
| Shutdown | |
| Ph10 | Shutdown, actuator opens in CLOSE position (home run) |
| Ph72 | Actuator opens in high-fire position / end of operation |
| Ph74 | Postpurging |
| Valve proving | |
| Ph80 | Test space evacuating |
| Ph81 | Checking time fuel valve 1 |
| Ph82 | Test space filling |
| Ph83 | Checking time fuel valve 2 |
| Waiting phases (start prevention) | |
| Ph01 | Undervoltage |
| Ph02 | Safety loop open |
| Ph04 | Extraneous light at burner startup (timeout / locking after 30 seconds) |
| Ph90 | Pressure switch-min open → safety shutdown |
| Lockout | |
| LOC | Lockout phase |

Error code list with operation via internal AZL :

| Error code | Clear text | Possible cause |
|-------------------|---|---|
| Loc 2 | No establishment of flame at the end of the safety time (TSA) | <ul style="list-style-type: none"> - Faulty or soiled fuel valves - Faulty or soiled flame detector - Poor adjustment of burner, no fuel - Faulty ignition equipment |
| Loc 3 | Air pressure faulty (air pressure switch (LP) welded in no-load position, decrease to specified time (t10) (air pressure switch (LP) response time) | <ul style="list-style-type: none"> Air pressure switch (LP) faulty - Loss of air pressure signal after specified time (t10) - Air pressure switch (LP) is welded in no-load position |
| Loc 4 | Extraneous light | Extraneous light when burner startup |
| Loc 5 | Air pressure faulty, air pressure switch welded in working position | <ul style="list-style-type: none"> Time out air pressure switch (LP) - Air pressure switch (LP) is welded in working position |
| Loc 6 | Fault of actuator | <ul style="list-style-type: none"> - Actuator faulty or blocked - Faulty connection - Wrong adjustment |
| Loc 7 | Loss of flame | <ul style="list-style-type: none"> Too many losses of flame during operation (limitation of repetitions) - Faulty or soiled fuel valves - Faulty or soiled flame detector - Poor adjustment of burner |
| Loc 8 | --- | Free |
| Loc 9 | --- | Free |
| Loc 10 | Error not relatable (application), internal error | Wiring error or internal error, output contacts, other faults |
| Loc 12 | Valve proving | Fuel valve 1 (V1) leak |
| Loc 13 | Valve proving | Fuel valve 2 (V2) leak |
| Loc 22 | Safety loop open | <ul style="list-style-type: none"> - Gas pressure switch-max open - Safety limit thermostat cut out |
| Loc 138 | Restore process successful | Restore process successful |
| Loc 167 | Manual locking | Manual locking |
| Loc: 206 | AZL2... incompatible | Use the latest version |

Entering the Parameter levels:

y means of a proper use of the keys, it is possible to enter the various level parameters, as shown in the following flow chart :

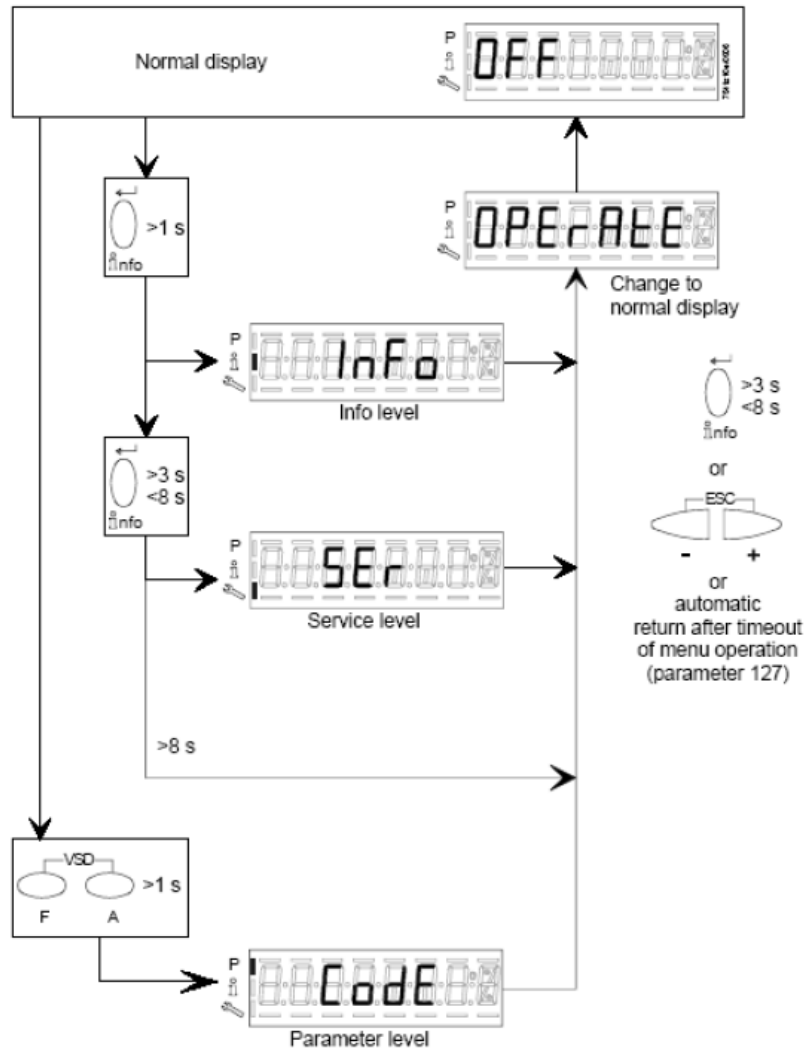

Info level :



Keep pushing the **info** button until **Info** appears. Use + or - for scrolling the parameter list. If on the right side a dash-dot appears, it means the display doesn't show the full description. Push **info** again for 1 to 3 s in order to show the full description.

Below the visible **Info** parameters:

| Parameter number | Parameter list PME73.000Ax + PME73.831AxBC LME73.831AxBC | Edit | Value range | | Resolution | Factory setting | Password level reading from level | Password level writing from level |
|------------------|--|------------|-------------|----------|------------|-----------------|-----------------------------------|-----------------------------------|
| | | | Min. | Max. | | | | |
| 100 | General | | | | | | | |
| 102 | Identification date | Read only | --- | --- | --- | | Info | --- |
| 103 | Identification number | Read only | 0 | 9999 | 1 | | Info | --- |
| 113 | Burner identification | Read only | x | xxxxxxxx | 1 | | Info | --- |
| 164 | Numbers of startups resettable | Resettable | 0 | 999999 | 1 | | Info | Info |
| 166 | Total number of startups | Read only | 0 | 999999 | 1 | | Info | --- |
| 170.00 | Switching cycles actuator relay K12 | Read only | 0 | 999999 | 1 | | Info | --- |
| 170.01 | Switching cycles actuator relay K11 | Read only | 0 | 999999 | 1 | | Info | --- |
| 170.02 | Switching cycles actuator relay K2 | Read only | 0 | 999999 | 1 | | Info | --- |
| 170.03 | Switching cycles actuator relay K1 | Read only | 0 | 999999 | 1 | | Info | --- |
| 171 | Max. switching cycles actuator relay | Read only | 0 | 999999 | 1 | | Info | --- |

Service level :



Keep pushing the **Info** button until full description. Push **Info** again for 1 to 3 s in order to show the full description.

Below the visible **Info** parameters:

| Parameter number | Parameter list PME73.000Ax + PME73.831AxBC LME73.831AxBC | Edit | Value range | | Resolution | Factory setting | Password level reading from level | Password level writing from level |
|------------------|---|-----------|---------------------|------------------------------|--------------------|-----------------|-----------------------------------|-----------------------------------|
| | | | Min. | Max. | | | | |
| 700 | Error history | | | | | | | |
| 701 | Current error: 00: Error code 01: Startup meter reading 02: MMI phase 03: Power value | Read only | 2 0 --- 0% | 255 999999 --- 100% | 1 1 --- 1 | | Service | --- |
| 702 | Error history former 1: 00: Error code 01: Startup meter reading 02: MMI phase 03: Power value | Read only | 2 0 --- 0% | 255 999999 --- 100% | 1 1 --- 1 | | Service | --- |
| • | | | | | | | | |
| • | | | | | | | | |
| • | | | | | | | | |
| 711 | Error history former 10: 00: Error code 01: Startup meter reading 02: MMI phase 03: Power value | Read only | 2 0 --- 0% | 255 999999 --- 100% | 1 1 --- 1 | | Service | --- |
| | | | | | | | | |

| 900 | Process data | | | | | | | |
|-----|------------------|-----------|-----|--|--------|--|---------|-----|
| 936 | Normalized speed | Read only | 0% | 100% | 0.01 % | | Service | --- |
| 951 | Mains voltage | Read only | 0 V | LME73.000A1: 175 V LME73.000A2: 350 V | 1 V | | Service | --- |
| 954 | Flame intensity | Read only | 0% | 100% | 1% | | Service | --- |

Parameter level (Heating engineering) :

This level lets the engineer to modify some burner parameters. It is protect with a 4 digit password (SO level) and a 5 digit password (OEM level)

Password input : push **F** and **A** buttons together until the display shows "**code**" and 7 underlines. The left one flashes. By **+** or **-** move the flashing underline until it is on the desired position and push "enter". The underline becomes a dash. By means of **+** or **-**, choose the right character and push "enter". Input the whole password and the **PARA** appears and later on **000 Int** .

Scroll the parameters using **+** or **-**: **000Int, 100, 200, 500, 600 are on the display**. Choose the proper parameter group with the **enter** button and scroll the options with **+** e poi **-** (below the full par set: the two columns on the right give the level access). Choose the parameter to be modified with "enter" is writing is allowed. The parameter now flashes: **+** or **-** modifies the parameter and **enter** confirms. **+** and **-** pushed together movbe the menu one step back. Push **+** and **-** several times in order to get the home position..

| Parameter number | Parameter list PME73.000Ax + PME73.831AxBC LME73.831AxBC | Edit | Value range | | Resolution | Factory setting | Password level reading from level | Password level writing from level |
|------------------|---|------|-------------|----------|------------|-----------------|-----------------------------------|-----------------------------------|
| | | | Min. | Max. | | | | |
| 0 | Internal parameter | | | | | | | |
| 41 | Heating engineers password (4 characters) | Edit | xxxx | xxxx | --- | | --- | OEM |
| 42 | OEM's password (5 characters) | Edit | xxxxx | xxxxx | --- | | --- | OEM |
| 60 | Backup / restore | Edit | Restore | Backup | --- | | --- | SO |
| 100 | General | | | | | | | |
| 123 | Min. power control step | Edit | 1% | 10% | 0.1 | | SO | SO |
| 140 | Mode display of Display and operating unit AZL2... 1 = Standard (program phase) 2 = Flame 1 (QRA... / ION) 3 = Flame 2 (QRB... / QRC...) 4 = Active power (power value) | Edit | 1 | 4 | 4 | | SO | SO |
| 200 | Burner control | | | | | | | |
| 224 | Specified time (t10) air pressure switch (LP) | Edit | 0 s | 13.818 s | 0.294 s | 12,054 | SO | OEM |
| 225 | Gas: Prepurge time (t1) | Edit | 0 s | 1237 s | 4.851 s | 29,106 | SO | OEM |
| 226 | Gas: Preignition time (t3) | Edit | 1.029 s | 37.485 s | 0.147 s | 2,058 | SO | OEM |
| 230 | Interval (t4): End of safety time (TSA) - fuel valve 1 (V1) ON | Edit | 3.234 s | 74.97 s | 0.294 s | 3,234 | SO | OEM |
| 231 | Interval (t9): Fuel valve 1 (V1) ON - pilot valve (PV) OFF | Edit | 0 s | 74.97 s | 0.294 s | 2,940 | SO | OEM |
| 232 | Interval (t5): Pilot valve (PV) OFF - load controller (LR) release | Edit | 2.058 s | 74.97 s | 0.294 s | 8.820 | SO | OEM |
| 234 | Gas: Postpurge time (t8) | Edit | 0 s | 1237 s | 4.851 s | 0 | SO | OEM |
| 239 | Gas: Intermittent operation after 24 hours of continuous operation 0=OFF 1=ON | Edit | 0 | 1 | 1 | 1 | SO | OEM |

| | | | | | | | | |
|------------|---|------|---------|----------|---------|--------|----|-----|
| 240 | Repetition in the event of loss of flame during operation 0 = None 1 = None 2 = 1 x Repetition | Edit | 0 | 2 | 1 | 0 | SO | OEM |
| 241.00 | Valve proving 0 = Off 1 = On | Edit | 0 | 1 | 1 | 1 | SO | OEM |
| 241.01 | Valve proving 0 = During prepurge time (t1) 1 = During postpurge time (t8) | Edit | 0 | 1 | 1 | 0 | SO | OEM |
| 241.02 | Valve proving 0 = According to P241.01 1 = During prepurge time (t1) and postpurge time (t8) | Edit | 0 | 1 | 1 | 0 | SO | OEM |
| 242 | Valve proving test space evacuating | Edit | 0 s | 2.648 s | 0.147 s | 2,646 | SO | OEM |
| 243 | Valve proving time test atmospheric pressure | Edit | 1.029 s | 37.485 s | 0.147 s | 10,290 | SO | OEM |
| 244 | Valve proving test space filling | Edit | 0 s | 2.648 s | 0.147 s | 2,646 | SO | OEM |
| 245 | Valve proving time test gas pressure | Edit | 1.029 s | 37.485 s | 0.147 s | 10,290 | SO | OEM |
| 254 | Response time detector error 0 = 1 s 1 = 3 s | Edit | 0 | 1 | 1 | 0 | SO | OEM |
| 257 | Gas: Postignition time (t3n – 0.3 seconds) | Edit | 0 s | 13.23 s | 0.147 s | 2,205 | SO | OEM |
| 259.00 | Opening time of actuator (t11) (timeout for lockout) | Edit | 0 s | 1237 s | 4.851 s | 67,914 | SO | OEM |
| 259.01 | Opening time of actuator from ignition load to low-fire position | Edit | 0 s | 37.485 s | 0.147 s | 14,994 | SO | OEM |
| 259.02 | Opening time of actuator from low-fire to ignition load position | Edit | 0 s | 37.485 s | 0.147 s | 14,994 | | |
| 260 | Closing time of actuator (t12) (timeout for lockout) | Edit | 0 s | 1237 s | 4.851 s | 67,914 | SO | OEM |
| 500 | Ratio control | | | | | | | |
| 515 | Actuator position during prepurge time (t1) and postpurge time (t8) 0: Purging in low-fire 1: Purging in high-fire | Edit | 0 | 1 | 1 | 1 | SO | OEM |
| 560 | Pneumatic combustion control 0 = off / 3-step modulation 1 = PWM fan / analog modulation 2 = air damper / analog modulation (feedback potentiometer ASZxx.3x required) | Edit | 0 | 2 | 1 | 1 | SO | SO |
| | | | | | | | | |
| | | | | | | | | |

| 600 Power setting | | | | | | | | | |
|-------------------|--|------|---|---|---|---|----|----|--|
| 654 | Analog input (feedback potentiometer ASZxx.3x required) 0 = 3-position step input 1 = 0...10 V 2 = 0...135 Ω 3 = 0...20 mA 4 = 4...20 mA with lockout at I <4 mA 5 = 4...20 mA | Edit | 0 | 5 | 1 | 0 | SO | SO | |

WARNING

Parameter Num. :

41
42
60
123
140
242
243
244
245
259.01

**Adjustable parameters from SO or OEM levels for
LME73.831AxBC**

Note: Specifications and data subject to change. Errors and omissions excepted.



USER'S MANUAL

COD. M12925CA Rel 1.2 08/2014

SOFTWARE VERSION 1.0x T73
code 80379 / Edition 01 - 06/2012



1 • INSTALLATION

• Dimensions and cut-out; panel mounting

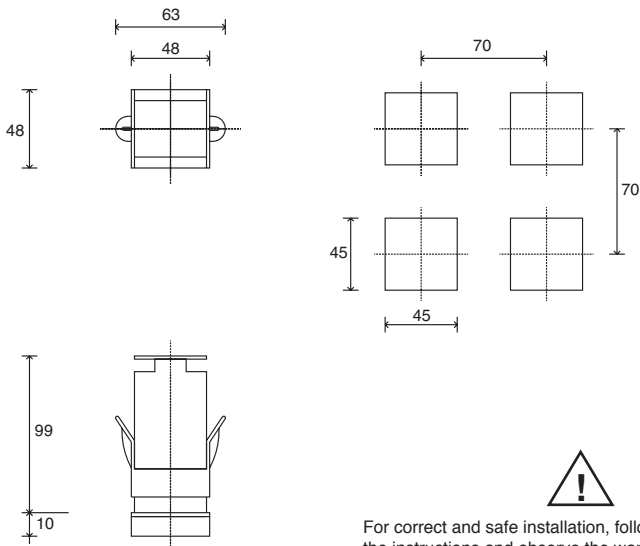

For correct and safe installation, follow the instructions and observe the warnings contained in this manual.

Panel mounting:

To fix the unit, insert the brackets provided into the seats on either side of the case. To mount two or more units side by side, respect the cut-out dimensions shown in the drawing.

CE MARKING: The instrument conforms to the European Directives 2004/108/CE and 2006/95/CE with reference to the generic standards: **EN 61000-6-2** (immunity in industrial environment) **EN 61000-6-3** (emission in residential environment) **EN 61010-1** (safety).

MAINTENANCE: Repairs must be done only by trained and specialized personnel.

Cut power to the device before accessing internal parts.

Do not clean the case with hydrocarbon-based solvents (Petrol, Trichlorethylene, etc.). Use of these solvents can reduce the mechanical reliability of the device. Use a cloth dampened in ethyl alcohol or water to clean the external plastic case.

SERVICE: GEFRA has a service department. The warranty excludes defects caused by any use not conforming to these instructions.

EMC conformity has been tested with the following connections

| FUNCTION | CABLE TYPE | LENGTH |
|--------------------|---------------------------------|--------|
| Power supply cable | 1 mm ² | 1 m |
| Relay output cable | 1 mm ² | 3,5 m |
| TC input | 0,8 mm ² compensated | 5 m |
| Pt100 input | 1 mm ² | 3 m |

2 • TECHNICAL SPECIFICATIONS

| | |
|--|--|
| Display | 2x4 digit green, high display 10 and 7mm |
| Keys | 4 of mechanical type (Man/Aut, INC, DEC, F) |
| Accuracy | 0.2% f.s. ±1 digit ambient temperature 25°C |
| Main input (settable digital filter) | TC, RTD, PTC, NTC 60mV, 1V Ri≥1MΩ; 5V, 10V Ri≥10KΩ; 20mA Ri=50Ω Tempo di campionamento 120 msec. |
| Type TC Thermocouples (ITS90) | Type TC Thermocouples : J,K,R,S,T (IEC 584-1, CEI EN 60584-1, 60584-2) ; custom linearization is available / types B,E,N,L GOST,U,G,D,C are available by using the custom linearization. |
| Cold junction error | 0,1° / °C |
| RTD type (scale configurable within indicated range, with or without decimal point) (ITS90) Max line resistance for RTD | DIN 43760 (Pt100), JPT100 20Ω |
| PTC type / NTC Type | 990Ω, 25°C / 1KΩ, 25°C |
| Safety | detection of short-circuit or opening of probes, LBA alarm |
| °C / °F selection | configurable from faceplate |
| Linear scale ranges | -1999 to 9999 with configurable decimal point position |
| Controls | PID, Self-tuning, on-off |
| pb - dt - it | 0,0...999,9 % - 0,00...99,99 min - 0,00...99,99 min |
| Action | Heat / Cool |
| Control outputs | on / off |
| Maximum power limit heat / cool | 0,0...100,0 % |
| Cycle time | 0...200 sec |
| Main output type | relay, logic, continuous (0...10V Rload ≥ 250KΩ, 0/4...20mA Rload ≤ 500Ω) |
| Softstart | 0,0...500,0 min |
| Fault power setting | -100,0...100,0 % |
| Automatic blanking | Displays PV value, optional exclusion |
| Configurable alarms | Up to 3 alarm functions assignable to an output, configurable as: maximum, minimum, symmetrical, absolute/deviation, LBA |
| Alarm masking | - exclusion during warm up - latching reset from faceplate or external contact |
| Type of relay contact | NO (NC), 5A, 250V/30Vdc cosφ=1 |
| Logic output for static relays | 24V ±10% (10V min at 20mA) |
| Transmitter power supply | 15/24Vdc, max 30mA short-circuit protection |
| Power supply (switching type) | (std) 100 ... 240Vac ±10% (opt.) 11...27Vac/dc ±10%; 50/60Hz, 8VA max |
| Faceplate protection | IP65 |
| Working / Storage temperature range | 0...50°C / -20...70°C |
| Relative humidity | 20 ... 85% non-condensing |
| Environmental conditions of use | for internal use only, altitude up to 2000m |
| Installation | Panel, plug-in from front |
| Weight | 160g for the complete version |

3 · DESCRIPTION OF FACEPLATE

Function indicators
Indicates modes of operation

L1 MAN/AUTO = OFF (automatic control)
ON (manual control)

L2 PRE-HEATING = ON (running)

L3 SELFTUNING = ON (enabled Self)
OFF (disabled Self)

Automatic/Manual adjustment selection
Active only when PV display visualises the process variable (button pressed for at least 5 sec.)

"Inc" and "Dec" key
Press to increment (decrement) any numerical parameter •• Increment (decrement) speed is proportional to time key stays pressed •• The operation is not cyclic: once the maximum (minimum) value of a field is reached, the value will not change even if the key remains pressed.

Indication of output states
OUT 1 (AL1); OUT 2 (OPEN); OUT 3 (CLOSED)

PV Display: Indication of process variable
Error Indication: LO, HI, Sbr, Err
LO= the value of process variable is < di LO_S
HI= the value of process variable is > di HI_S
Sbr= faulty sensor or input values higher than max. limits
Err= PT100 third wire opened for PT100, PTC or input values lower than min. limits (i.e.: TC wrong connection)

SV display: Indication of setpoint

Function key
Gives access to the various configuration phases •• Confirms change of set parameters and browses next or previous parameter (if Auto/Man key is pressed)

4 · CONNECTIONS

• Outputs

Out2 (19) - 5A at 250Vac/30Vdc relay

Out1 (20) - 5A/250Vac relay

Out3 (6) - 5A at 250Vac/30Vdc relay

TOP

• Inputs

• TC Input

Available thermocouples: J, K, R, S, T (B, E, N, L, U, G, D, C custom linearization is available)

- Observe polarities
- For extensions, use the correct compensating cable for the type of TC used

• Power Supply

Standard: 100...240Vac ± 10%

Optional: 11...27Vac/Vdc ± 10%

Max. power 8VA; 50/60 Hz

• Linear input (I)

Linear input in dc current

20mA, Ri = 50Ω

• Input 1 linear with transmitter 2 wires

• Identification of boards

Power board - Solder side

Select transmitter voltage

N.B. : you can keep the **OUT1** relay energized at power-up by inserting jumper **S2** and removing resistance **R20**.

CPU board - Component side

IN/OUT boards (see appendix)

Select signal at contact 3

• Linear input (V)

Linear input in dc voltage

60mV, 1V, Ri > 1MΩ, 5V, 10V, Ri > 10KΩ

• Pt100 / PTC / NTC

Use wires of adequate diameter (min. 1mm²)

PT100, JPT100, PTC, NTC

• Device structure

5 • “EASY” PROGRAMMING and CONFIGURATION

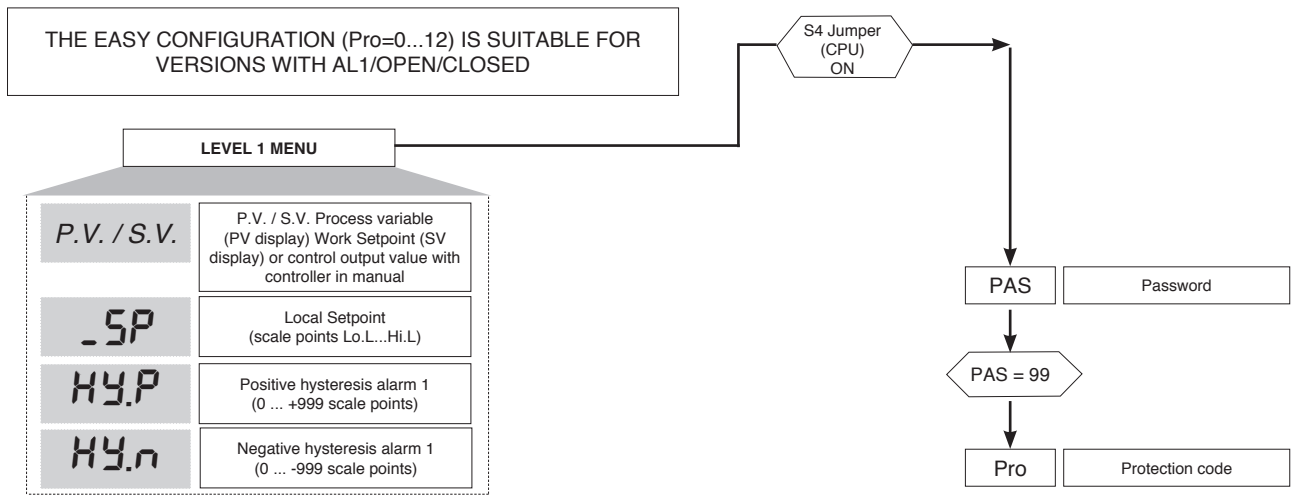

• Prot

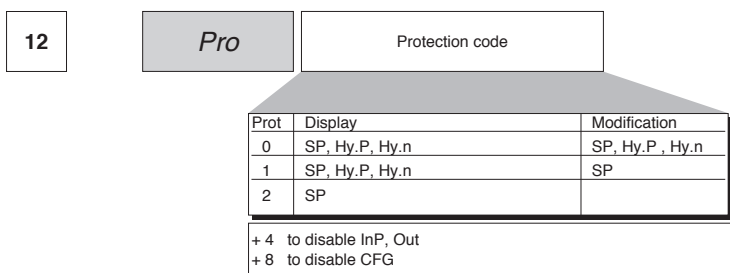

6 • PROGRAMMING and CONFIGURATION

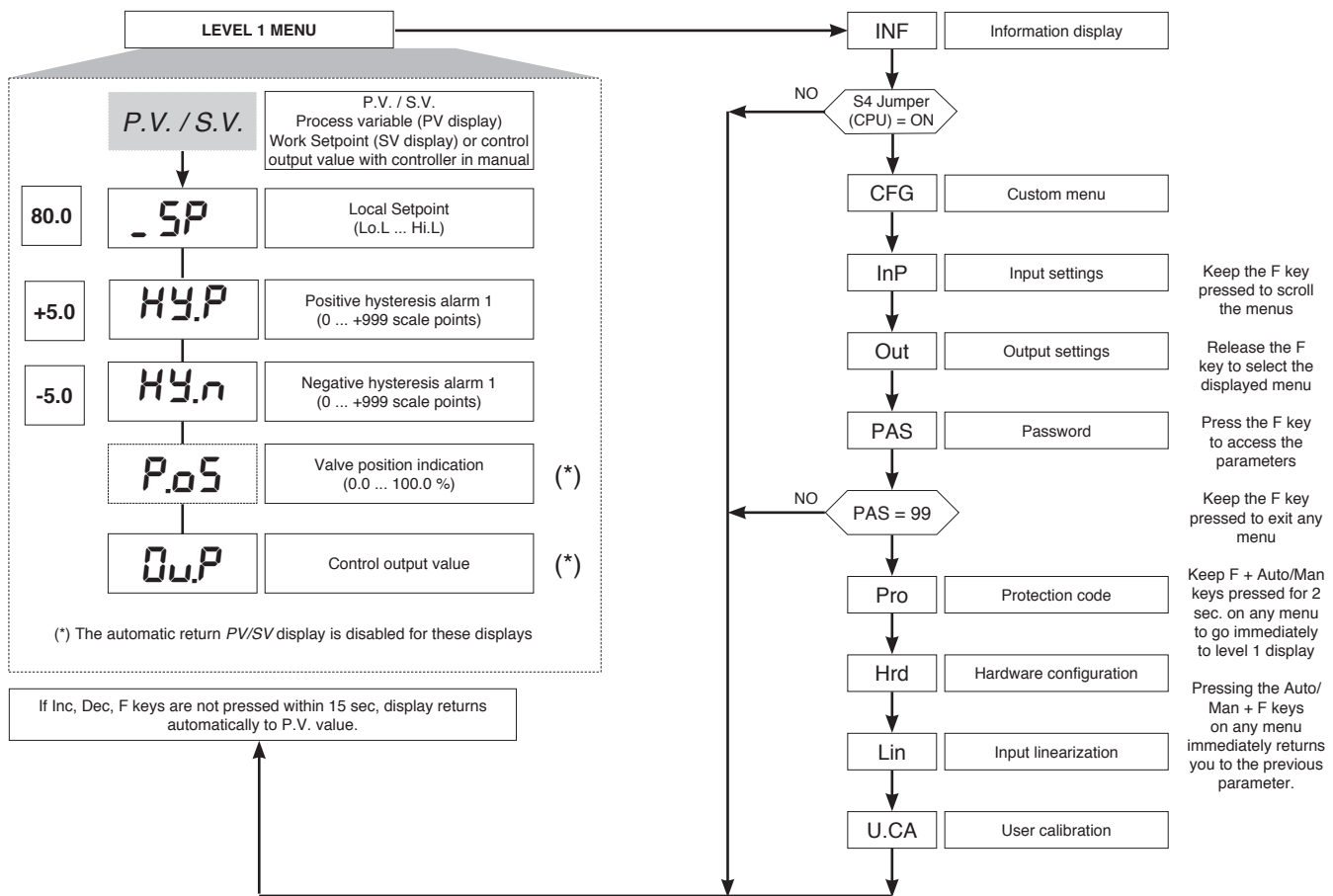

N.B.: Once a particular configuration is entered, all unnecessary parameters are no longer displayed

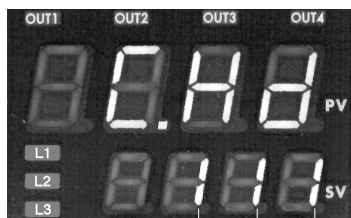

| | | |
|-----------------|-----------------|-----------------------------|
| OUTPUT 2 | OUTPUT 3 | SERIAL COMMUNICATION |
| 0 = None | 0 = None | 0 = None |
| 1 = Relay | 1 = Relay | |

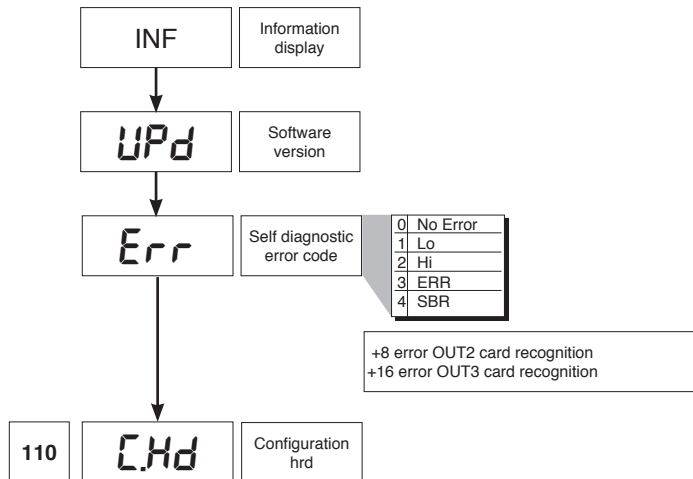

• CFG

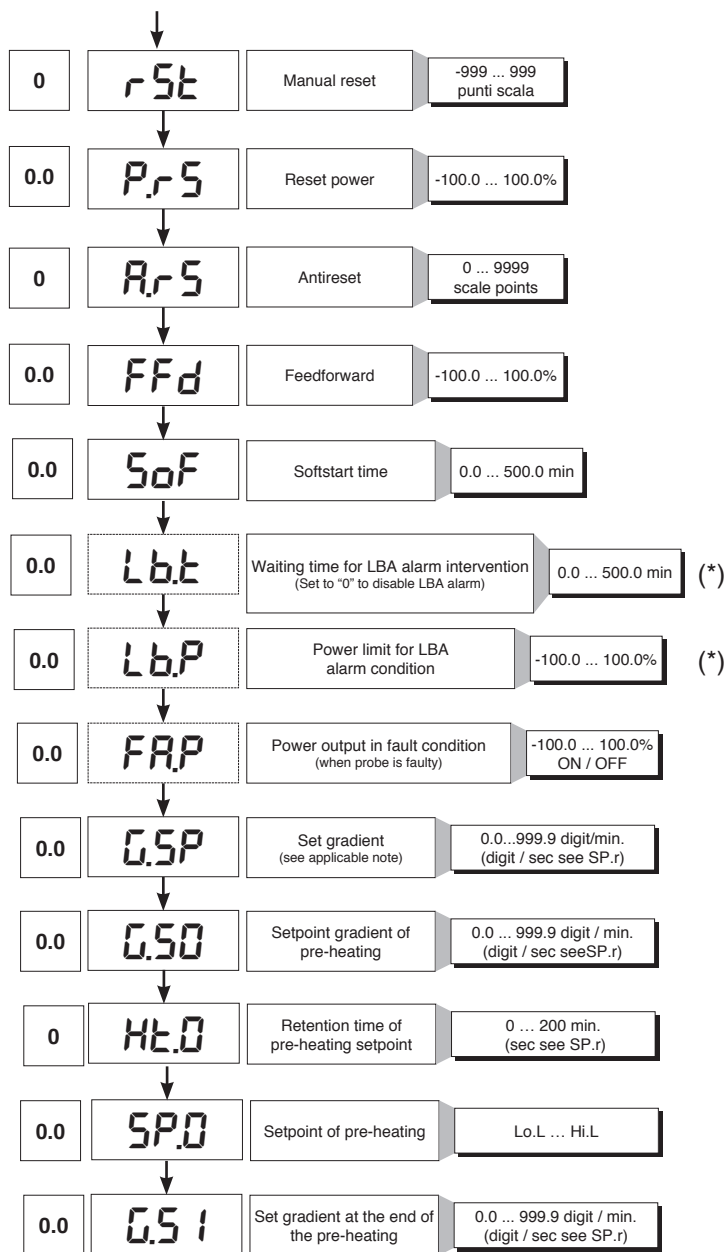
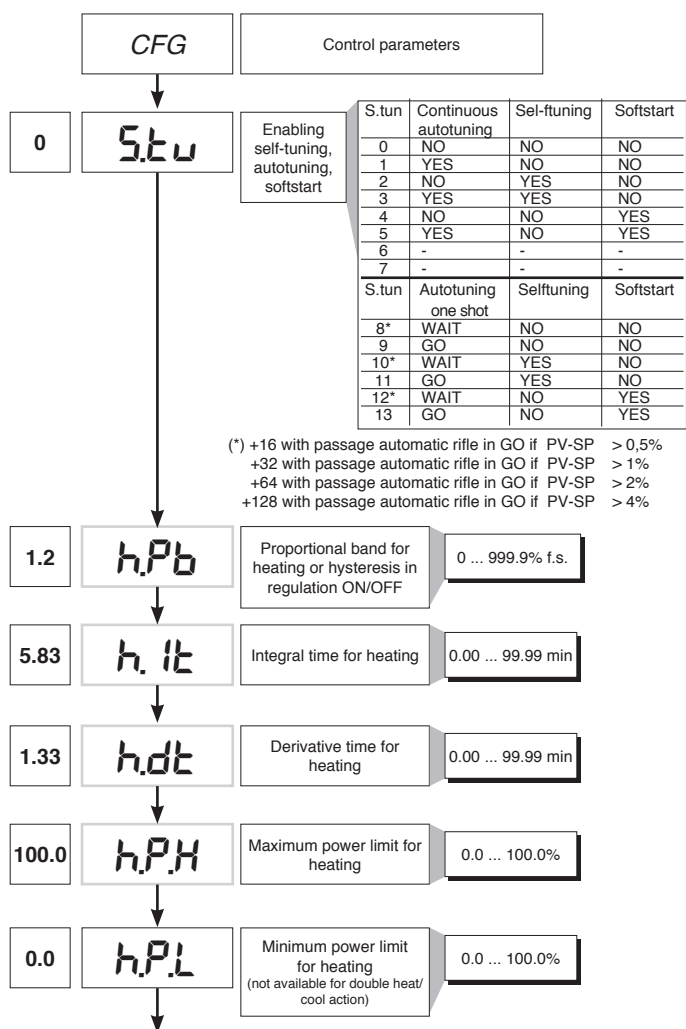

(*) LBA alarm may be reset by simultaneously pressing Δ + ▽ keys when OutP is displayed or by switching to Manual.

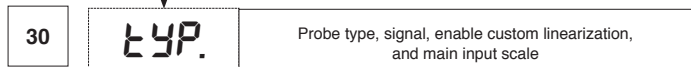
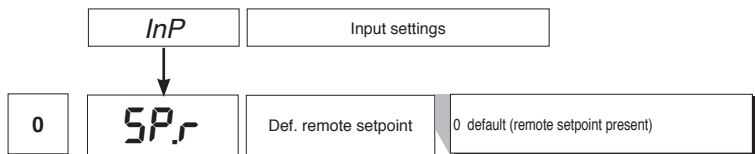

| Type | Probe type | without decimal point | with decimal point |
|----------|---------------|-----------------------|--------------------|
| Sensore: | | | |
| TC | | | |
| 0 | TC J °C | 0/1000 | 0.0/999.9 |
| 1 | TC J °F | 32/1832 | 32.0/999.9 |
| 2 | TC K °C | 0/1300 | 0.0/999.9 |
| 3 | TC K °F | 32/2372 | 32.0/999.9 |
| 4 | TC R °C | 0/1750 | 0.0/999.9 |
| 5 | TC R °F | 32/3182 | 32.0/999.9 |
| 6 | TC S °C | 0/1750 | 0.0/999.9 |
| 7 | TC S °F | 32/3182 | 32.0/999.9 |
| 8 | TC T °C | -200/400 | -199.9/400.0 |
| 9 | TC T °F | -328/752 | -199.9/752.0 |
| 28 | TC | CUSTOM | CUSTOM |
| 29 | TC | CUSTOM | CUSTOM |
| 30 | PT100 °C | -200/850 | -199.9/850.0 |
| 31 | PT100 °F | -328/156.2 | -199.9/999.9 |
| 32 | JPT100 °C | -200/600 | -199.9/600.0 |
| 33 | JPT100 °F | -328/1112 | -199.9/999.9 |
| 34 | PTC °C | -55/120 | -55.0/120.0 |
| 35 | PTC °F | -67/248 | -67.0/248.0 |
| 36 | NTC °C | -10/70 | -10.0/70.0 |
| 37 | NTC °F | 14/158 | 14.0/158.0 |
| 38 | 0...60 mV | -1999/9999 | -199.9/999.9 |
| 39 | 0...60 mV | Custom scale | Custom scale |
| 40 | 12...60 mV | -1999/9999 | -199.9/999.9 |
| 41 | 12...60 mV | Custom scale | Custom scale |
| 42 | 0...20 mA | -1999/9999 | -199.9/999.9 |
| 43 | 0...20 mA | Custom scale | Custom scale |
| 44 | 4...20 mA | -1999/9999 | -199.9/999.9 |
| 45 | 4...20 mA | Custom scale | Custom scale |
| 46 | 0...10 V | -1999/9999 | -199.9/999.9 |
| 47 | 0...10 V | Custom scale | Custom scale |
| 48 | 2...10 V | -1999/9999 | -199.9/999.9 |
| 49 | 2...10 V | Custom scale | Custom scale |
| 50 | 0...5 V | -1999/9999 | -199.9/999.9 |
| 51 | 0...5 V | Custom scale | Custom scale |
| 52 | 1...5 V | -1999/9999 | -199.9/999.9 |
| 53 | 1...5 V | Custom scale | Custom scale |
| 54 | 0...1 V | -1999/9999 | -199.9/999.9 |
| 55 | 0...1 V | Custom scale | Custom scale |
| 56 | 200mv...1V | -1999/9999 | -199.9/999.9 |
| 57 | 200mv...1V | Custom scale | Custom scale |
| 58 | Cust10 V-20mA | -1999/9999 | -199.9/999.9 |
| 59 | Cust10 V-20mA | Custom scale | Custom scale |
| 60 | Cust 60mV | -1999/9999 | -199.9/999.9 |
| 61 | Cust 60mV | Custom scale | Custom scale |
| 62 | PT100-JPT | CUSTOM | CUSTOM |
| 63 | PTC | CUSTOM | CUSTOM |
| 64 | NTC | CUSTOM | CUSTOM |

For custom linearization:
 - LO signal is generated with variable below Lo.S or at minimum calibration value
 - HI signal is generated with variable above Lo.S or at maximum calibration value

Max. non-linearity error for thermocouples (TC), resistors (PT100) and thermistors (PTC, NTC).
 The error is calculated as deviation from theoretical value and is expressed as percentage of full scale (in °C).

S, R range 0...1750°C; error < 0.2% f.s. (t > 300°C) / for other range; error < 0.5% f.s.
T error < 0.2% f.s. (t > -150°C)
B range 44...1800°C; error < 0.5% f.s. (t > 300°C) / range 44.0...999.9; error < 1% f.s. (t > 300°C)
U range -99.9...99.9 and -99...99°C; error < 0.5% f.s. / for other range; error < 0.2% f.s. (t > -150°C)
G error < 0.2% f.s. (t > 300°C)
D error < 0.2% f.s. (t > 200°C)
C range 0...2300; error < 0.2% f.s. / for other range; error < 0.5% f.s.

NTC error < 0.5% f.s.

Tc: J, K, E, N, L error < 0,2% f.s.
 JPT100 and PTC error < 0,2% f.s.
 PT100 scale -200...850°C
 Precision better than 0,2% f.s. at 25°C
 In range 0...50°C:
 • Precision better than 0,2% f.s. in range -200...400°C
 • Precision better than 0,4% f.s. in range +400...850°C (where f.s. refers to range -200... +850°C)

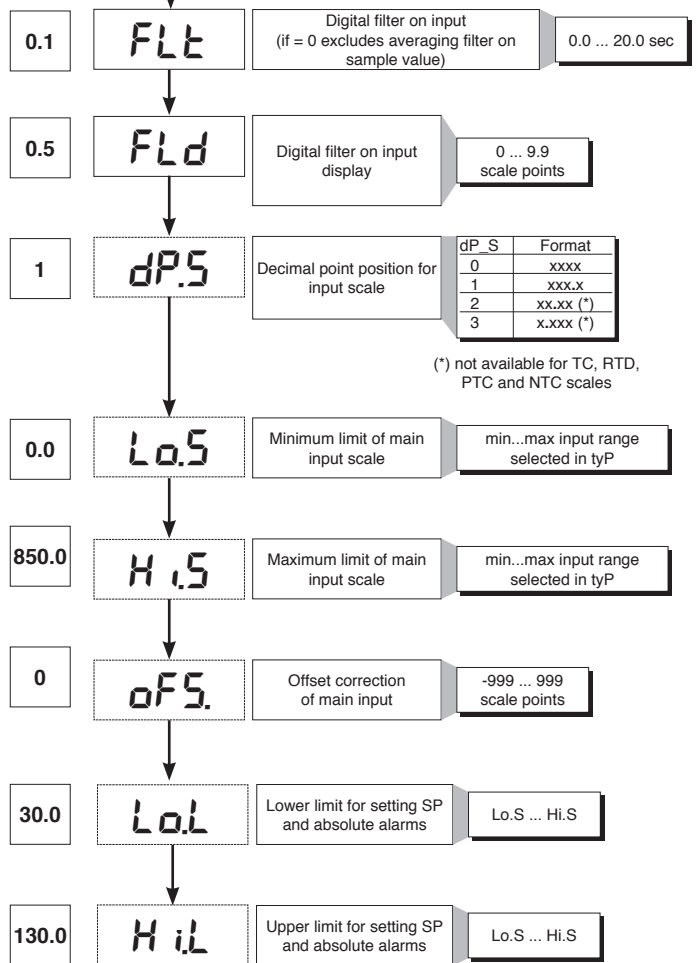

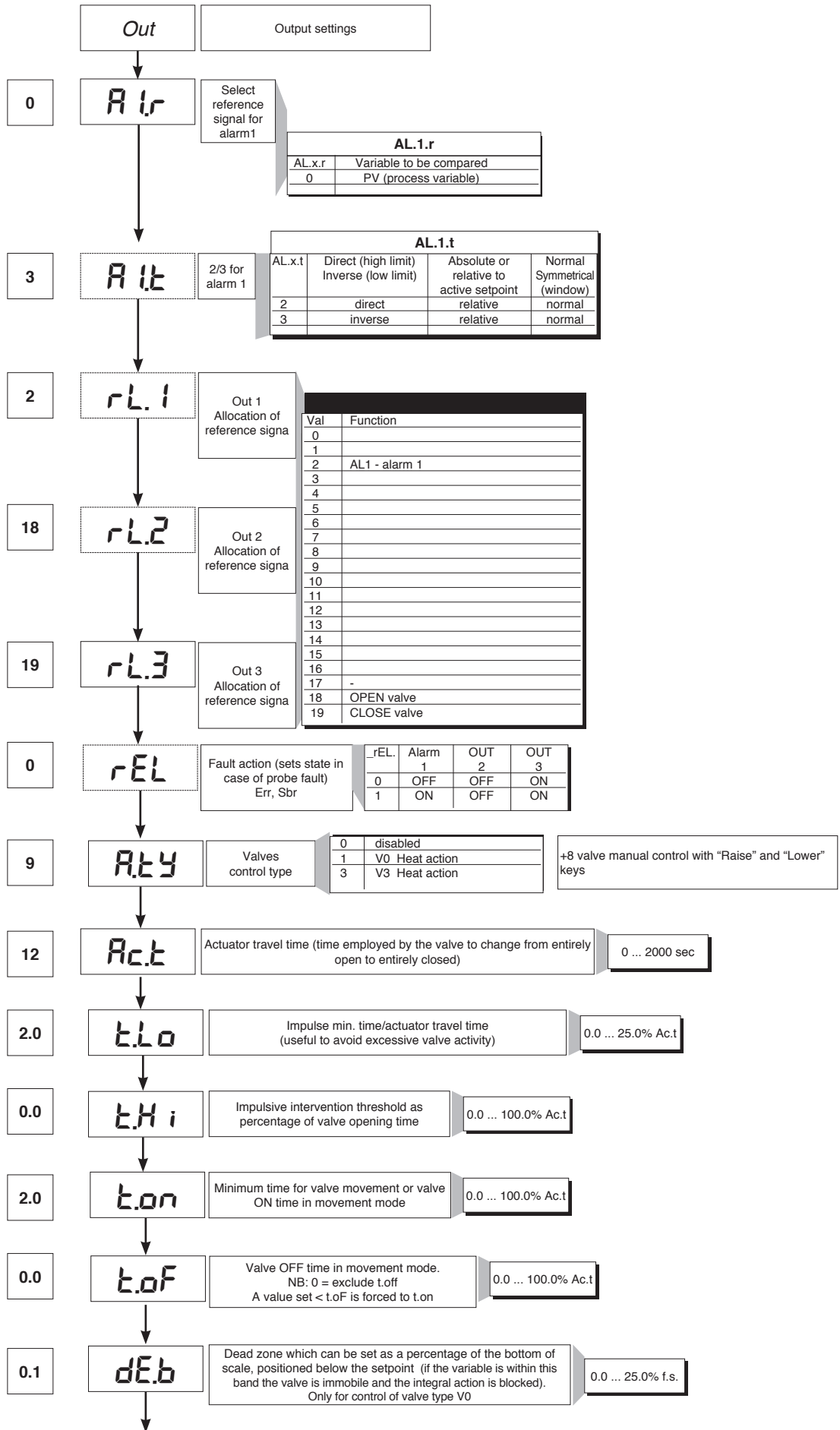

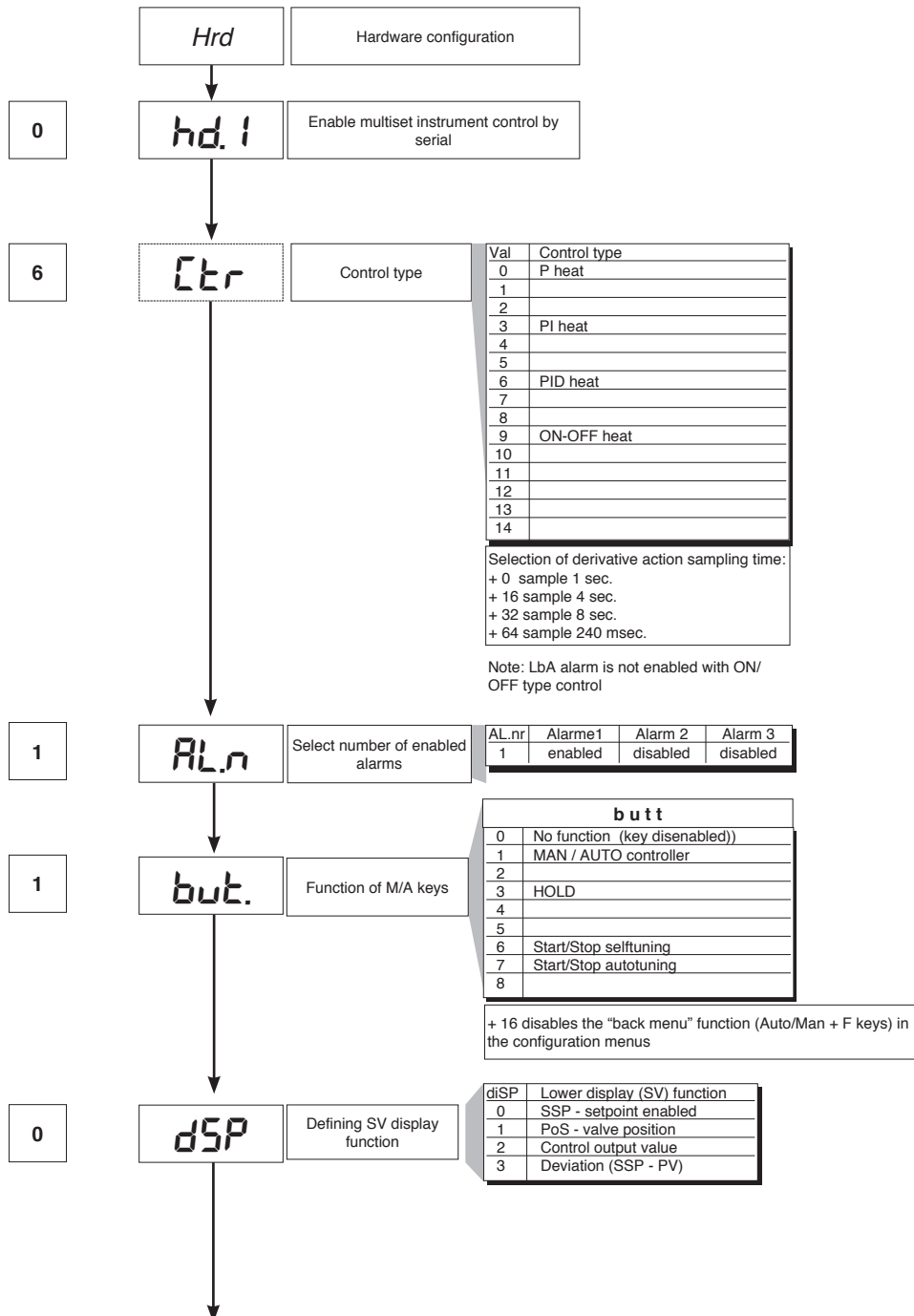
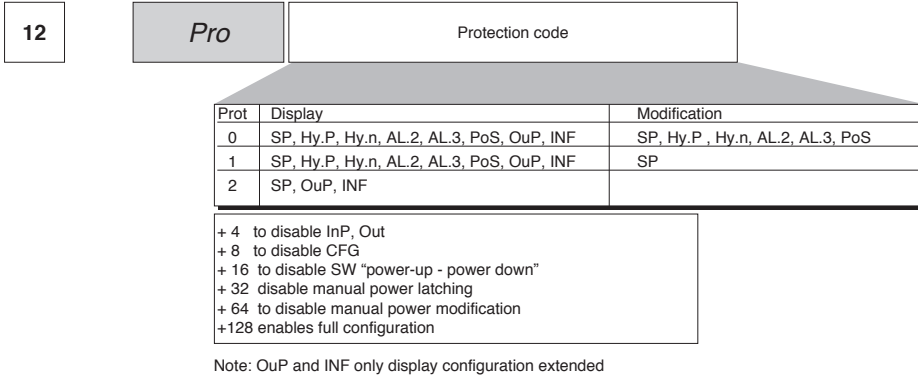

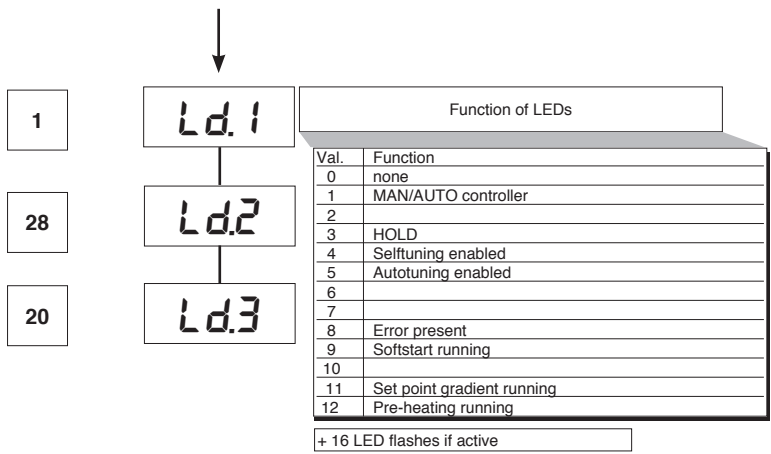

• Lin

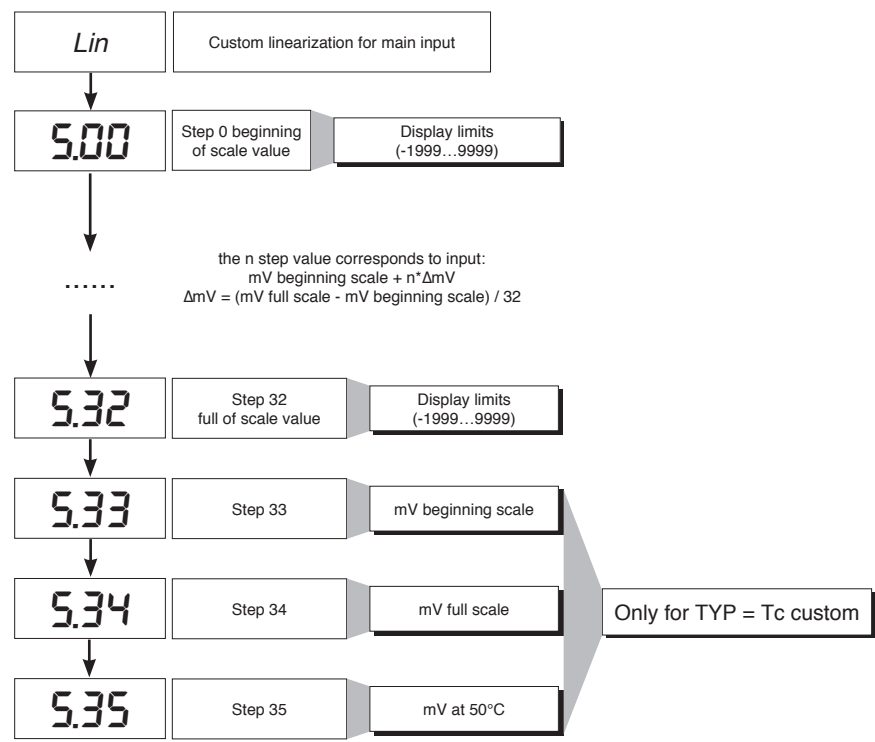

• U.CAL

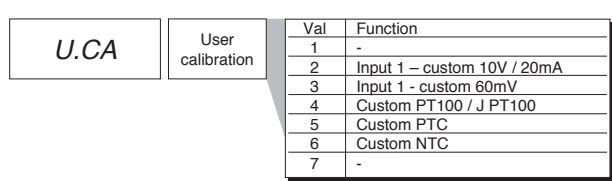

7 · CONSENT FOR BURNER AL1

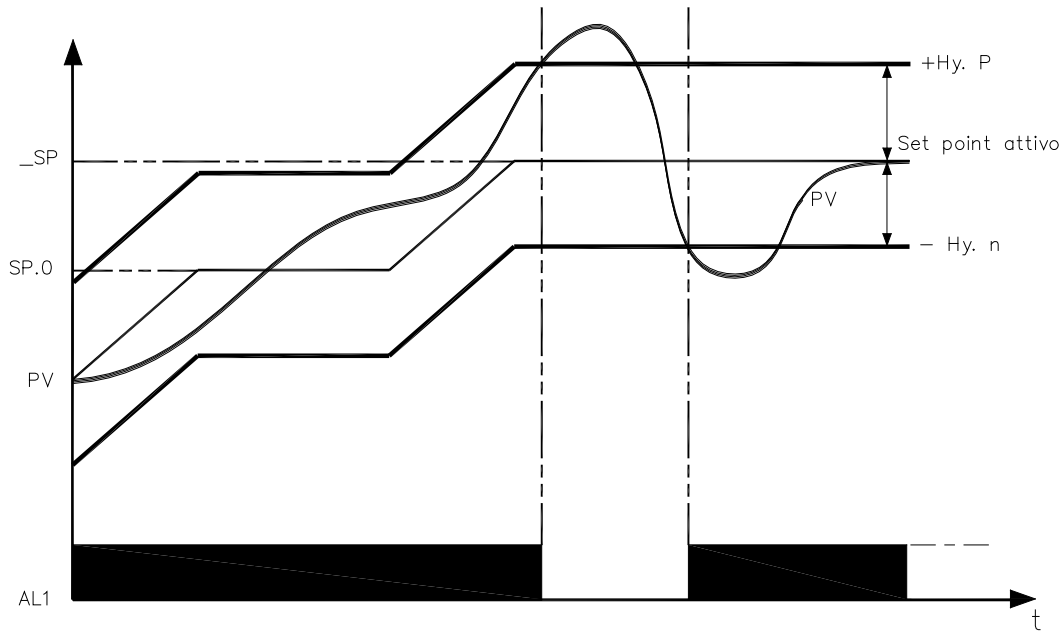

Obtain burner consent by configuring alarm 1 as inverse deviation with positive hysteresis Hy.P and negative hysteresis Hy.n

8 · PRE-HEATING FUNCTION

Enable the pre-heating function by setting parameters GS.0, Ht.0, GS.1 other than zero. It consists of three phases that are activated sequentially at firing:

- Ramp 0 phase

Enabled by setting $GS.0 > 0$. Starting from setpoint = PV (initial state), it reaches pre-heating set SP.0 with gradient GS.0

- Maintenance phase

Enabled by setting $Ht.0 > 0$. Maintains pre-heating setpoint SP.0 for time Ht.0

- Ramp 1 phase

Enabled by setting $GS.1 > 0$. Starting from pre-heating setpoint SP.0, it reaches active $_SP$ set with gradient GS.1

In case of selftuning, the pre-heating function is not activated

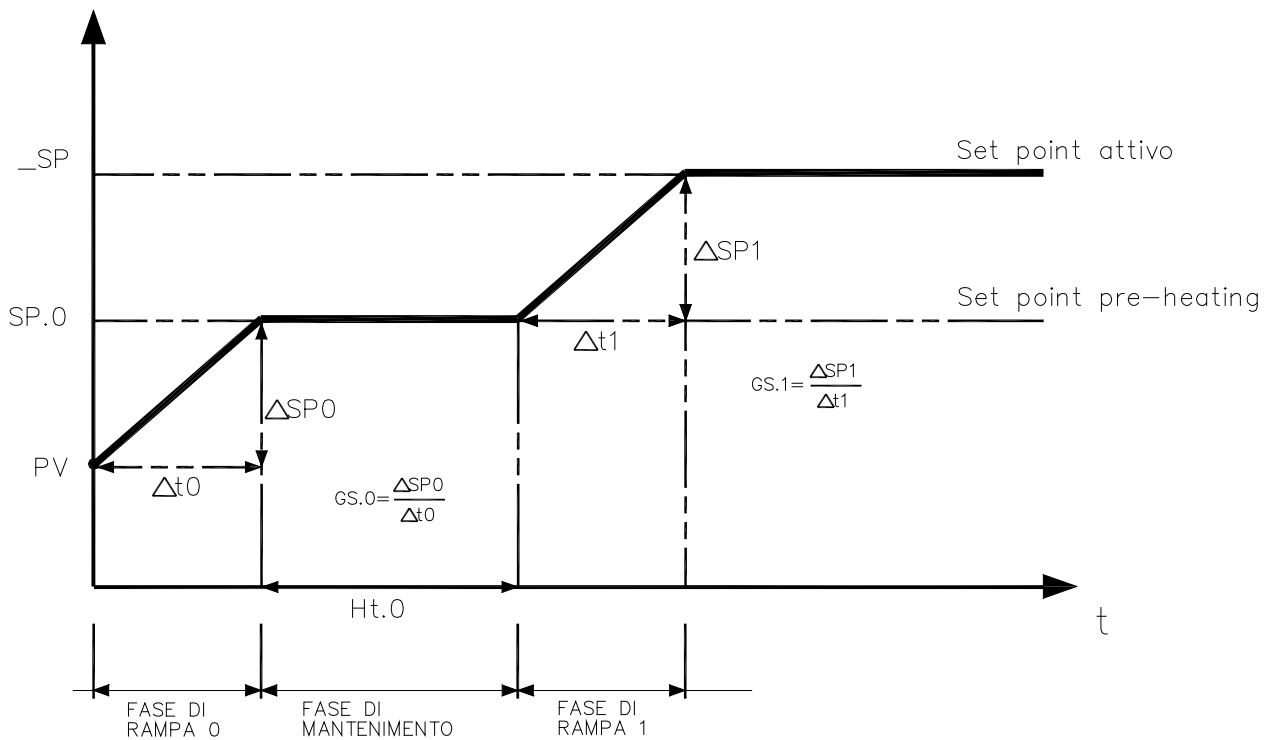

9 • ADJUSTMENT WITH MOTORIZED VALVE

In an adjustment process the adjustment valve has the function of varying fuel delivery (frequently corresponding to the thermal energy introduced into the process) in relation to the signal coming from the controller.

For this purpose it is provided with an actuator able to modify its opening value, overcoming the resistances produced by the fluid passing inside it.

The adjustment valves vary the delivery in a modulated manner, producing finite variations in the fluid passage inner area corresponding to finite variations of the actuator input signal, coming from the controller. The servomechanism, for example, comprises an electric motor, a reducer and a mechanical transmission system which actions the valve.

Various auxiliary components can be present such as the mechanical and electrical safety end travels, manual actioning systems.

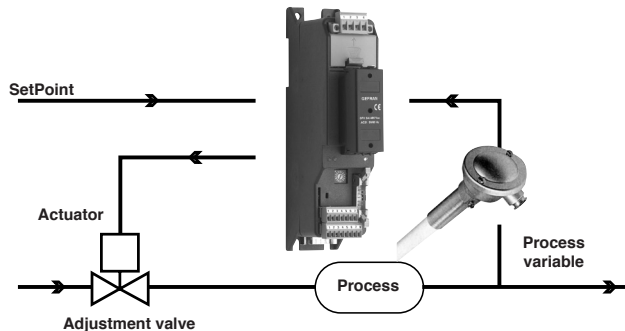

CONTROL EXAMPLE FOR V0 VALVE

The controller determines, on the basis of the dynamics of the process, the control output for the valve corresponding to the opening of the same in such a way so as to maintain the desired value of the process variable.

Characteristic parameters for valves control

- Actuator time ($A_c.t$) is the time employed by the valve to pass from entirely open to entirely closed (or vice-versa), and can be set with a resolution of one second. It is a mechanical feature of the valve+actuator unit.

NOTE: if the actuator's travel is mechanically limited it is necessary to proportionally reduce the $A_c.t$ value.

- Minimum impulse ($t.Lo$) expressed as a % of the actuator time (resolution 0.1%).

Represents the minimum change in position corresponding to a minimum change in power supplied by the instrument below which the actuator will not physically respond to the command.

This represents the minimum variation in position due to which the actuator does not physically respond to the command.

The minimum duration of the movement can be set in $t.Lo$, expressed as a % of actuator time.

- Impulsive intervention threshold ($t.Hi$) expressed as a % of the actuator time (resolution 0.1%) represents the position displacement (requested position – real position) due to which the manoeuvre request becomes impulsive.

You can choose between 2 types of control:

1) ON time of movement = $t.on$ and OFF time proportional to shift and greater than or equal to $t.Lo$ (we recommend setting $t.on = t.Lo$) (set $t.oF = 0$).

2) ON time of movement = $t.on$ and OFF time = $t.oF$. A value set for $t.oF < t.on$ is forced to $t.on$. To activate this type, set $t.oF >> 0$.

The type of movement approach allows fine control of the reverse drive valve (from potentiometer or not), especially useful in cases of high mechanical inertia. Set $t.Hi = 0$ to exclude modulation in positioning.

This type of modulated approach allows precise control of the feedback actioned valve, by a potentiometer or not, and is especially useful in cases of high mechanical inertia. Setting $t.Hi = 0$ excludes modulation in positioning.

- Dead zone ($dE.b$) is a displacement band between the adjustment setpoint and the process variable within which the controller does not supply any command to the valve (Open = OFF; Close = OFF). It is expressed as a percentage of the bottom scale and is positioned below the setpoint.

The dead zone is useful in an operative process to avoid straining the actuator with repeated commands and an insignificant effect on the adjustment. Setting $dE.b = 0$ the dead zone is excluded.

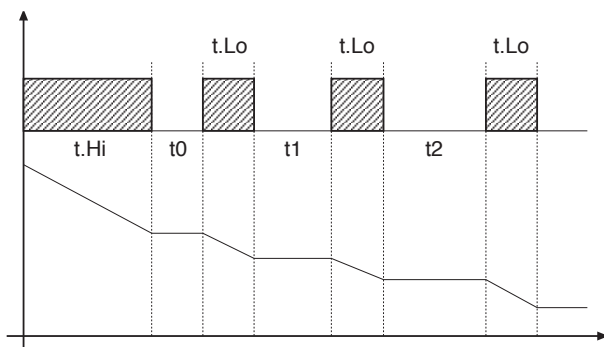

Graph of behavior inside the band with integral time $\neq 0$.

With integral time = 0, movement ON time is always equal to OFF time.

$t_0 = t.Lo$

Valve control modes

With the controller in manual, the setting of parameter At.y ≥ 8 allows direct control of the valve open and close commands through the keyboard Increments and Decrements on the front seats.

V0 - for floating valve without potentiometer

Model V0 have similar behaviour: every manoeuvre request greater than the minimum impulse t.Lo is sent to the actuator by means of the OPEN/CLOSE relays; every action updates the presumed position of the virtual potentiometer calculated on the basis of the actuator travel declared time.

In this way there is always a presumed position of the valve which is compared with the position request of the controller.

Having reached a presumed extreme position (entirely open or entirely closed determined by the "virtual potentiometer") the controller provides a command in the same direction, in this way ensuring the real extreme position is reached (minimum command time = t.on).

The actuators are usually protected against the OPEN command in the entirely open position or CLOSE command in the entirely closed position.

V3 - for floating valve, PI control

When the difference between the position calculated by the controller and the only proportional component exceeds the value corresponding to the minimum impulse t.Lo the controller provides an OPEN or CLOSE command of the duration of the minimum impulse itself t.Lo.

At each delivery the integral component of the command is set to zero (discharge of the integral).

The frequency and duration of the impulses is correlated to the integral time (h.it or c.it).

Non-movement behavior

t.Hi = 0: with power = 100% or 0.0%, the corresponding open or close outputs always remain enabled (safety status).

Movement behavior

t.Hi $\neq 0$: with position attained corresponding to 100% or 0.0%, the corresponding open or close outputs are switched off.

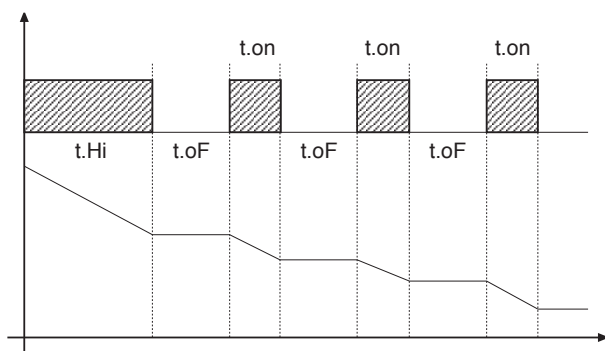

If t.oF = 0, current function is maintained.

If t.oF $\neq 0$ movement mode will be as shown on the graph

10 • CONTROL ACTIONS

Proportional Action:

action in which contribution to output is proportional to deviation at input (deviation = difference between controlled variable and setpoint).

Derivative Action:

action in which contribution to output is proportional to rate of variation input deviation.

Integral Action:

action in which contribution to output is proportional to integral of time of input deviation.

Influence of Proportional, Derivative and Integral actions on response of process under control

* An increase in P.B. reduces oscillations but increases deviation.

* A reduction in P.B. reduces the deviation but provokes oscillations of the controlled variable (the system tends to be unstable if P.B. value is too low).

* An increase in Derivative Action corresponds to an increase in Derivative Time, reduces deviation and prevents oscillation up to a critical value of Derivative Time, beyond which deviation increases and prolonged oscillations occur.

* An increase in Integral Action corresponds to a reduction in Integral Time, and tends to eliminate deviation between the controlled variable and the setpoint when the system is running at rated speed.

If the Integral Time value is too long (Weak integral action), deviation between the controlled variable and the setpoint may persist.

Contact GEFRA for more information on control actions.

11 • MANUAL TUNING

- A) Enter the setpoint at its working value.
- B) Set the proportional band at 0.1% (with on-off type setting).
- C) Switch to automatic and observe the behavior of the variable. It will be similar to that in the figure:

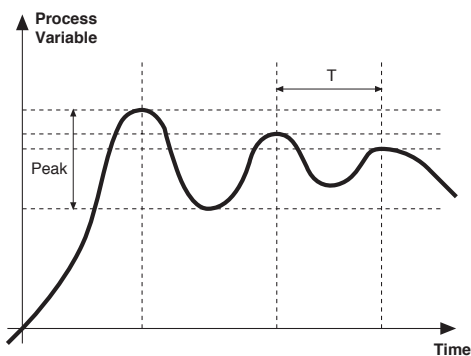

D) The PID parameters are calculated as follows: Proportional band

$$P.B. = \frac{\text{Peak}}{(V \text{ max} - V \text{ min})} \times 100$$

(V max - V min) is the scale range.

Integral time: $I_t = 1.5 \times T$

Derivative time: $d_t = I_t/4$

E) Switch the unit to manual, set the calculated parameters. Return to PID action by setting the appropriate relay output cycle time, and switch back to Automatic.

F) If possible, to optimize parameters, change the setpoint and check temporary response. If an oscillation persists, increase the proportional band. If the response is too slow, reduce it.

12 • SET GRADIENT

SET GRADIENT: if set to $\neq 0$, the setpoint is assumed equal to PV at power-on and auto/man switchover. With gradient set, it reaches the local setpoint. Every variation in setpoint is subject to a gradient.

The set gradient is inhibited at power-on when self-tuning is engaged.

If the set gradient is set to $\neq 0$, it is active even with variations of the local setpoint.

The control setpoint reaches the set value at the speed defined by the gradient.

13 • SOFTWARE ON / OFF SWITCHING FUNCTION

How to switch the unit OFF: hold down the “F” and “Raise” keys simultaneously for 5 seconds to deactivate the unit, which will go to the OFF state while keeping the line supply connected and keeping the process value displayed. The SV display is OFF.

All outputs (alarms and controls) are OFF (logic level 0, relays de-energized) and all unit functions are disabled except the switch-on function and digital communication.

How to switch the unit ON: hold down the “F” key for 5 seconds and the unit will switch OFF to ON. If there is a power failure during the OFF state, the unit will remain in OFF state at the next power-up (ON/OFF state is memorized).

The function is normally enabled, but can be disabled by setting the parameter Prot = Prot +16.

14 • SELF-TUNING

The function works for single output systems (heating or cooling). The self-tuning action calculates optimum control parameter values during process startup. The variable (for example, temperature) must be that assumed at zero power (room temperature).

The controller supplies maximum power until an intermediate value between starting value and setpoint is reached, after which it zeros power.

PID parameters are calculated by measuring overshoot and the time needed to reach peak. When calculations are finished, the system disables automatically and the control proceeds until the setpoint is reached.

How to activate self-tuning:

A. Activation at power-on

1. Set the setpoint to the required value
2. Enable selftuning by setting the Stun parameter to 2 (CFG menu)
3. Turn off the instrument
4. Make sure the temperature is near room temperature
5. Turn on the instrument again

B. Activation from keyboard

1. Make sure that key M/A is enabled for Start/Stop selftuning (code but = 6 Hrd menu)
2. Bring the temperature near room temperature
3. Set the setpoint to the required value
4. Press key M/A to activate selftuning (Attention: selftuning interrupts if the key is pressed again)

The procedure runs automatically until finished, when the new PID parameters are stored: proportional band, integral and derivative times calculated for the active action (heating or cooling). In case of double action (heating or cooling), parameters for the opposite action are calculated by maintaining the initial ratio between parameters (ex.: $CPb = HPb \times K$; where $K = CPb / HPb$ when self-tuning starts). When finished, the Stun code is automatically cancelled.

Notes :

-The procedure does not start if the temperature is higher than the setpoint (heating control mode) or if the temperature is lower than the setpoint (cooling control mode). In this case, the Stun code is not cancelled.

-It is advisable to enable one of the configurable LEDs to signal selftuning status. By setting one of parameters LED1, LED2, LED3=4 or 20 on the Hrd menu, the respective LED will be on or flashing when selftuning is active.

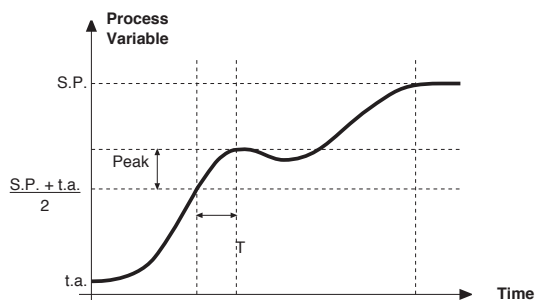

15 • ACCESSORIES

• Interface for instrument configuration



Kit for PC via the USB port (Windows environment) for GEFTRAN instruments configuration:

Lets you read or write all of the parameters

- A single software for all models
- Easy and rapid configuration
- Saving and management of parameter recipes
- On-line trend and saving of historical data

Component Kit:

- Connection cable PC USB ... port TTL
- Connection cable PC USB ... RS485 port
- Serial line converter
- CD SW GF Express installation

• ORDERING CODE

| | |
|--------------|-------------|
| GF_eXK-2-0-0 | cod F049095 |
|--------------|-------------|

16 • ORDER CODE

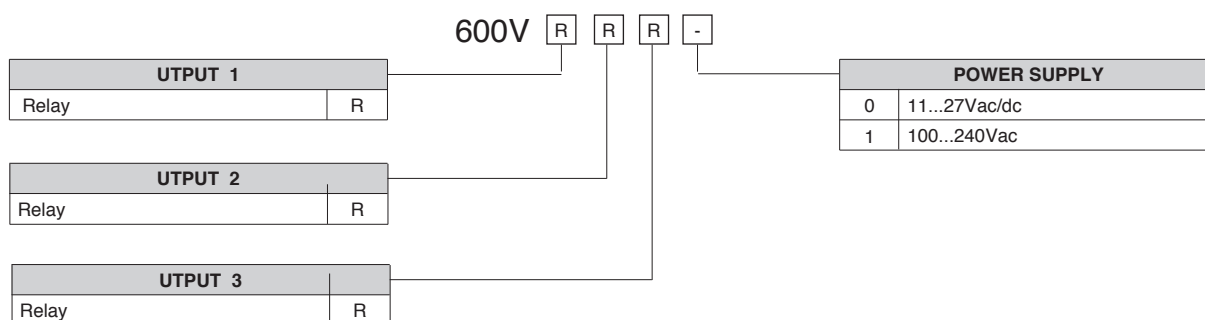

• WARNINGS

WARNING: this symbol indicates danger. It is placed near the power supply circuit and near high-voltage relay contacts.

Read the following warnings before installing, connecting or using the device:

- follow instructions precisely when connecting the device.
- always use cables that are suitable for the voltage and current levels indicated in the technical specifications.
- the device has no ON/OFF switch: it switches on immediately when power is turned on. For safety reasons, devices permanently connected to the power supply require a two-phase disconnecting switch with proper marking. Such switch must be located near the device and must be easily reachable by the user. A single switch can control several units.
- if the device is connected to electrically NON-ISOLATED equipment (e.g. thermocouples), a grounding wire must be applied to assure that this connection is not made directly through the machine structure.
- if the device is used in applications where there is risk of injury to persons and/or damage to machines or materials, it **MUST** be used with auxiliary alarm units. You should be able to check the correct operation of such units during normal operation of the device.
- before using the device, the user must check that all device parameters are correctly set in order to avoid injury to persons and/or damage to property.
- the device must **NOT** be used in inflammable or explosive environments. It may be connected to units operating in such environments only by means of suitable interfaces in conformity to local safety regulations.
- the device contains components that are sensitive to static electrical discharges. Therefore, take appropriate precautions when handling electronic circuit boards in order to prevent permanent damage to these components.

Installation: installation category II, pollution level 2, double isolation

The equipment is intended for permanent indoor installations within their own enclosure or panel mounted enclosing the rear housing and exposed terminals on the back.

- only for low power supply: supply from Class 2 or low voltage limited energy source
- power supply lines must be separated from device input and output lines; always check that the supply voltage matches the voltage indicated on the device label.
- install the instrumentation separately from the relays and power switching devices
- do not install high-power remote switches, contactors, relays, thyristor power units (particularly if "phase angle" type), motors, etc... in the same cabinet.
- avoid dust, humidity, corrosive gases and heat sources.
- do not close the ventilation holes; working temperature must be in the range of 0...50°C.

- surrounding air: 50°C
- use 60/75°C copper (Cu) conductor only, wire size range 2x No 22 - 14AWG, Solid/Stranded
- use terminal tightening torque 0.5N m

If the device has faston terminals, they must be protected and isolated; if the device has screw terminals, wires should be attached at least in pairs.

• **Power:** supplied from a disconnecting switch with fuse for the device section; path of wires from switch to devices should be as straight as possible; the same supply should not be used to power relays, contactors, solenoid valves, etc.; if the voltage waveform is strongly distorted by thyristor switching units or by electric motors, it is recommended that an isolation transformer be used only for the devices, connecting the screen to ground; it is important for the electrical system to have a good ground connection; voltage between neutral and ground must not exceed 1V and resistance must be less than 60hm; if the supply voltage is highly variable, use a voltage stabilizer for the device; use line filters in the vicinity of high frequency generators or arc welders; power supply lines must be separated from device input and output lines; always check that the supply voltage matches the voltage indicated on the device label.

• **Input and output connections:** external connected circuits must have double insulation; to connect analog inputs (TC, RTD) you have to: physically separate input wiring from power supply wiring, from output wiring, and from power connections; use twisted and screened cables, with screen connected to ground at only one point; to connect adjustment and alarm outputs (contactors, solenoid valves, motors, fans, etc.), install RC groups (resistor and capacitor in series) in parallel with inductive loads that work in AC (*Note: all capacitors must conform to VDE standards (class x2) and support at least 220 VAC. Resistors must be at least 2W*); fit a 1N4007 diode in parallel with the coil of inductive loads that operate in DC.

GEFRAN spa will not be held liable for any injury to persons and/or damage to property deriving from tampering, from any incorrect or erroneous use, or from any use not conforming to the device specifications.

Set-up for 600V RRR0-1-T73 regulator

Set up for temperature probe Pt100 (ex Siemens QAE2120 130°C max.)

The regulator comes out of the factory preset with the corresponding values of the Siemens RWF40.000 and RWF50.2x

Verify wiring of the sensor

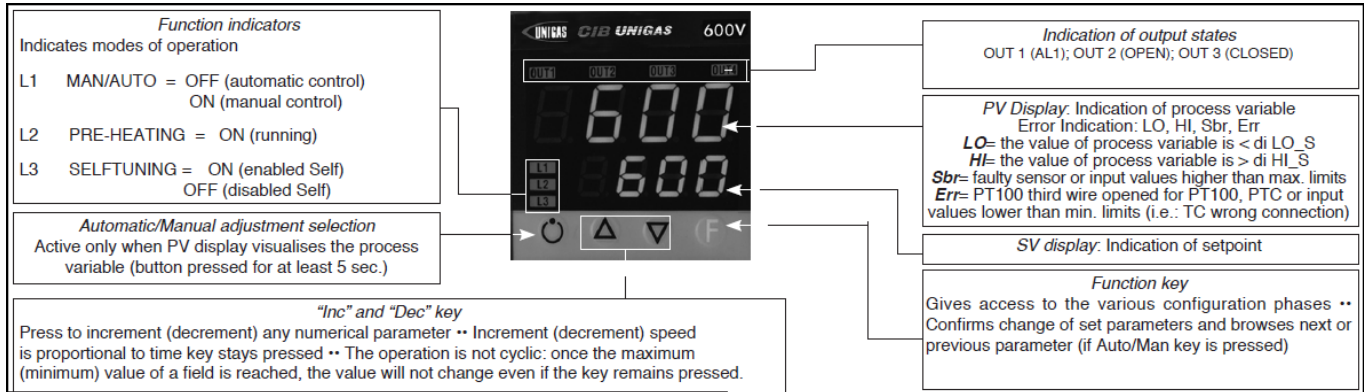

Regulation of the set-point = 80

It can be modified by using arrows "up" and "down".

By pushing F you go to parameters:

| | |
|------|--|
| Hy.P | 5 (hysteresis positive for output 1, terminals 21-22 (ex Q13-Q14)) |
| Hy.n | -5 hysteresis negative for output ,1 terminals 21-22 (ex Q13-Q14) |

Keep pushing F until you see **PASS**, release F and through the arrows set **99**, push F and visualize **Pro** (protection code) default is **12**, through the arrows set **128** and push F, keep it pushed until all parameters **InF**, **CFG**, **InP**, **Out**, **PASS** are visualized.

| CFG | |
|-------|------|
| S.tun | 0 |
| hPb | 1,2 |
| hIt | 5,83 |
| hdt | 1,33 |
| ... | |

| InP | |
|------|-------------------------------------|
| | |
| tyP | 30 (Pt100) |
| ... | |
| dP_S | 1 (decimals num.) |
| Lo.S | 0 (min. sensor scale) |
| Hi.S | 850,0 (max sensor scale) |
| oFS | 0 (offset of input correction) |
| Lo.L | 30,0 (lower set-point range limit) |
| Hi.L | 130,0 (upper set-point range limit) |

| Out | |
|------------|--|
| A1.r | 0 |
| ... | |
| A1.t | 3 (operating mode AL1 =inverse-relative-normal) |
| ... | |
| rL.1 | 2 (AL1) |
| rL.2 | 18 (open) |
| rL.3 | 19 (close) |
| rEL | 0 |
| A.ty | 9 (type of servocontrol command) |
| Ac.t | 12 (servocontrol running time: SQN72.4.../STA12..=12; SQM40.265=30) |
| t Lo | 2 |
| t Hi | 0.0 |
| t.on | 2 |
| t.oF | 0.0 |
| dE.b | 0,1 (dead zone in % of end scale) |
| | |

| | |
|------------|---|
| PAS | 99 then push and keep pushed F until visualization of Hrd |
| | |
| Hrd | |
| ... | |
| Ctrl | 6 (PID warm) |
| AL.nr | 1 |
| but | 1 |
| diSP | 0 |
| Ld.1 | 1 |
| Ld.2 | 28 |
| Ld.3 | 20 |

Keep pushed **F** until you visualize **PASS**, release **F** and through the arrows set **99**, push **F** and visualize **Pro** (protection code) from **128**, through the arrows, bring it back to **12**, and keep **F** pushed until you come back to set-point value.

Manual operation :

Keep pushed the lower left key for at least 5 sec.

The instrument will enter the "MAN" mode (see also "Ld1" switching on).

Through the arrows, "Open" and "Close" outputs are activated.

To come back to normal working keep the lower left key pushed for at least 5 sec.

Software switch off :

By keeping pushed keys **Arrow up** + **F** for more than 5 sec. the instrument switches off the software, does not command the outputs and visualize only the variable of process measured by the probe.

To restore keep pushed **F** for more than 5 sec.

Set up for temperature probe Pt100 for high temperature (350°C max.)

Verify wiring of the sensor

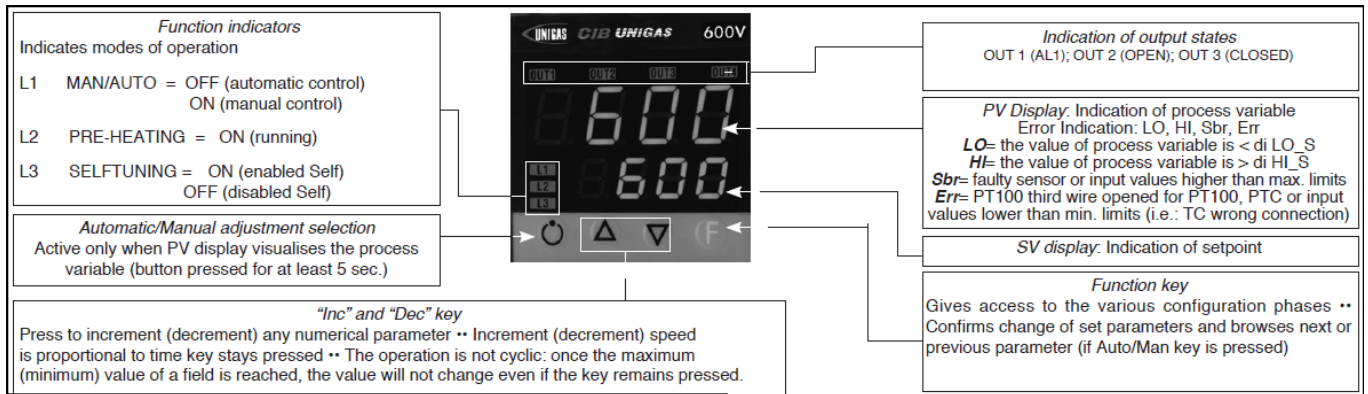

Regulation of the set-point = **80**

It can be modified by using arrows "up" and "down".

By pushing **F** you go to parameters:

| | |
|------|--|
| Hy.P | 10 (hysteresis positive for output 1 terminals 21-22 (ex Q13-Q14)) |
| Hy.n | -5 (hysteresis negative for output 1 terminals 21-22 (ex Q13-Q14)) |

Keep pushing **F** until you see **PASS**, release **F** and through the arrows set **99**, push **F** and visualize **Pro** (protection code) default is **12**, through the arrows set **128** and push **F**, keep it pushed until all parameters **InF**, **CFG**, **InP**, **Out**, **PASS** are visualized.

| CFG | |
|-------|------|
| S.tun | 0 |
| hPb | 1,2 |
| hIt | 5,83 |
| hdt | 1,33 |
| ... | |

| InP | |
|------|-------------------------------------|
| | |
| tyP | 30 (Pt100) |
| ... | |
| dP_S | 1 (decimals num.) |
| Lo.S | 0 (min. sensor scale) |
| Hi.S | 850,0 (max sensor scale) |
| oFS | 0 (offset of input correction) |
| Lo.L | 0,0 (lower set-point range limit) |
| Hi.L | 350,0 (upper set-point range limit) |

| Out | |
|------------|--|
| A1.r | 0 |
| ... | |
| A1.t | 3 (mode AL1 =inverse-relative-normal) |
| ... | |
| rL.1 | 2 (AL1) |
| rL.2 | 18 (open) |
| rL.3 | 19 (close) |
| rEL | 0 |
| A.ty | 9 (type of servocontrol command) |
| Ac.t | 12 (servocontrol running time: SQN72.4.../STA12..=12; SQM40.265=30) |
| t Lo | 2 |
| t Hi | 0.0 |
| t.on | 2 |
| t.oF | 0.0 |
| dE.b | 0,1 (dead zone in % of end scale) |

| | |
|------------|---|
| PAS | 99 then push and keep pushed F until visualization of Hrd |
| | |
| Hrd | |
| ... | |
| Ctrl | 6 (PID warm) |
| AL.nr | 1 |
| but | 1 |
| diSP | 0 |
| Ld.1 | 1 |
| Ld.2 | 28 |
| Ld.3 | 20 |

Keep pushed **F** until you visualize **PASS**, release **F** and through the arrows set **99**, push **F** and visualize **Pro** (protection code) from **128**, through the arrows, bring it back to **12**, and keep **F** pushed until you come back to set-point value.

Manual operation:

Keep pushed the lower left key for at least 5 sec.

The instrument will enter the "MAN" mode (see also "Ld1" switching on).

Through the arrows, "Open" and "Close" outputs are activated.

To come back to normal working keep the lower left key pushed for at least 5 sec.

Software switch off :

By keeping pushed keys **Arrow up** + **F** for more than 5 sec. the instrument switches off the software, does not command the outputs and visualize only the variable of process measured by the probe.

To restore keep pushed **F** for more than 5 sec.

Set up for pressure transmitter 2 wires signal 4÷20mA

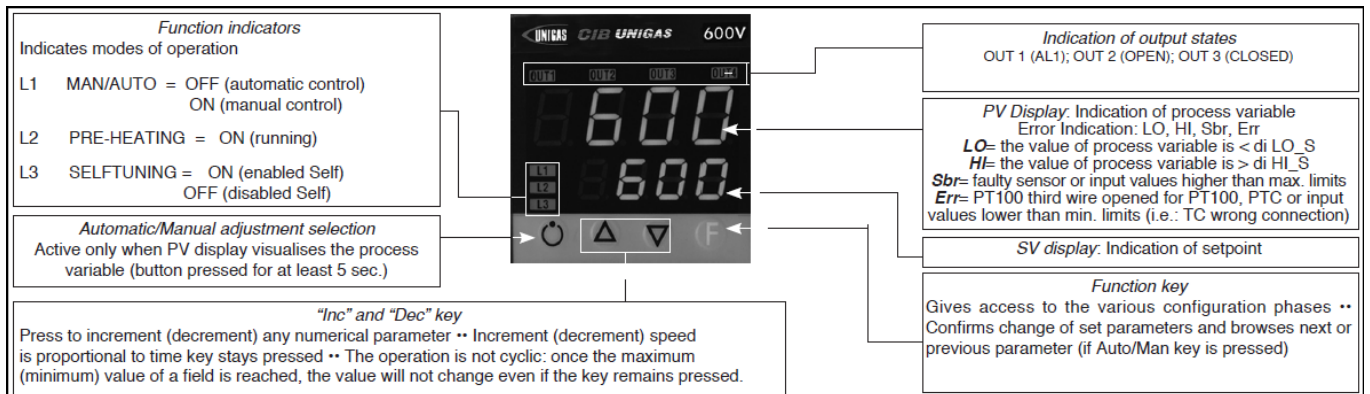

With pressure transmitters first we need to enable their power supply: remove the part as shown below, then, on the CPU unit, move the bridge from Pt100 to +Vt

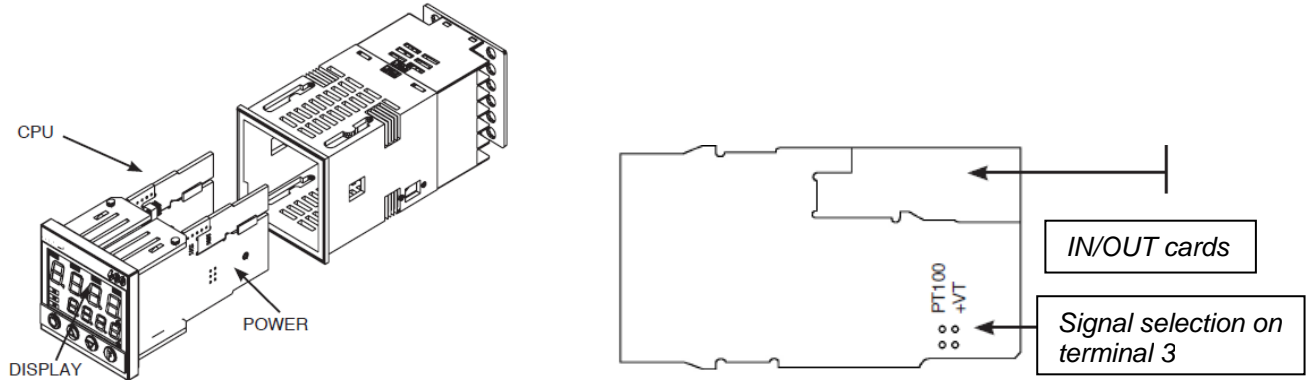

Verify wiring of the sensor

Impostazione set-point

| Transmitter | 1,6bar | 3bar | 10bar | 16bar | 25bar | 40bar |
|-------------|--------|--------|-------|-------|-------|-------|
| Set-point | 1bar | 1,5bar | 6bar | 6bar | 6bar | 6bar |

To modify it directly use "up" and "down" arrows.

By pushing **F** you go to parameter:

| Transmitter | 1,6bar | 3bar | 10bar | 16bar | 25bar | 40bar |
|-------------|--------|--------|--------|--------|---------|-------|
| Hy.P | 0,2bar | 0,5bar | 0,5bar | 0,8bar | 1,25bar | 2bar |
| Hy.n | 0bar | 0bar | 0bar | 0bar | 0bar | 0bar |

Keep pushing **F** until you see **PASS**, release **F** and through the arrows set **99**, push **F** and visualize **Pro** (protection code) default is **12**, through the arrows set **128** and push **F**, keep it pushed until all parameters **InF**, **CFG**, **InP**, **Out**, **PASS** are visualized.

| CFG | |
|-------|------|
| S.tun | 0 |
| hPb | 5 |
| hIt | 1,33 |
| hdt | 0,33 |
| ... | |

| InP | |
|------|-------------------|
| | |
| tyP | 44 (4÷20mA) |
| ... | |
| dP_S | 2 (decimals num.) |

| Transmitter | 1,6bar | 3bar | 10bar | 16bar | 25bar | 40bar | |
|-------------|--------|------|-------|-------|-------|-------|----------------------------|
| Lo.S | 0,00 | 0,00 | 0,00 | 0,00 | 0,00 | 0,00 | min. sensor scale |
| Hi.S | 1,60 | 3,00 | 10,00 | 16,00 | 25,00 | 40,00 | max sensor scale |
| oFS | 0 | 0 | 0 | 0 | 0 | 0 | offset of input correction |
| Lo.L | 0,00 | 0,00 | 0,00 | 0,00 | 0,00 | 0,00 | lower set-point setting |
| Hi.L | 1,60 | 3,00 | 10,00 | 16,00 | 25,00 | 40,00 | upper set-point setting |

| Out | |
|------|--|
| A1.r | 0 |
| ... | |
| A1.t | 3 (mode AL1 =inverse-relative-normal) |
| ... | |
| rL.1 | 2 (AL1) |
| rL.2 | 18 (open) |
| rL.3 | 19 (close) |
| rEL | 0 |
| A.ty | 9 (type of servocontrol command) |
| Ac.t | 12 (servocontrol running time: SQN72.4.../STA12..=12; SQM40.265=30) |
| t Lo | 2 |
| t Hi | 0.0 |
| t.on | 2 |
| t.oF | 0.0 |
| dE.b | 0,1 (dead zone in % of end scale) |

| PAS | 99 then push and keep pushed F until visualization of Hrd |
|------------|---|
| | |
| Hrd | |
| ... | |
| Ctrl | 6 (PID warm) |
| AL.nr | 1 |
| but | 1 |
| diSP | 0 |
| Ld.1 | 1 |
| Ld.2 | 28 |
| Ld.3 | 20 |

Keep pushed **F** until you visualize **PASS**, release **F** and through the arrows set **99**, push **F** and visualize **Pro** (protection code) from **128**, through the arrows, bring it back to **12**, and keep **F** pushed until you come back to set-point value.

Manual operation:

Keep pushed the lower left key for at least 5 sec.

The instrument will enter the "MAN" mode (see also "Ld1" switching on).

Through the arrows, "Open" and "Close" outputs are activated.

To come back to normal working keep the lower left key pushed for at least 5 sec.

Software switch off :

By keeping pushed keys **Arrow up** + **F** for more than 5 sec. the instrument switches off the software, does not command the outputs and visualize only the variable of process measured by the probe.

To restore keep pushed **F** for more than 5 sec.

Set-up for thermocouples type **K** or **J**

Verify wiring of the sensor

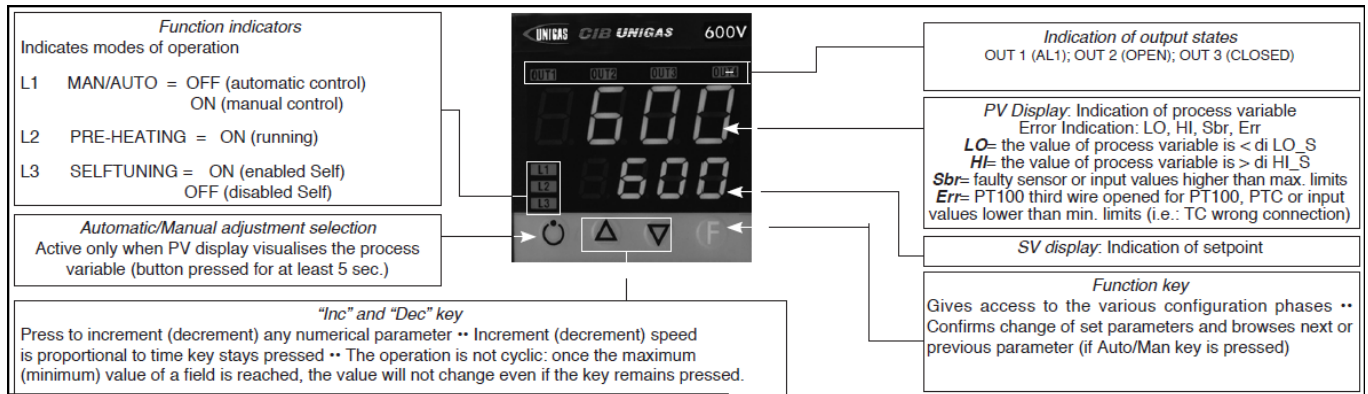

Regulation of the set-point = **80**

It can be modified by using arrows "up" and "down".

By pushing **F** you go to parameters:

| | |
|------|--|
| Hy.P | 10 (hysteresis positive for output 1 terminals 21-22 (ex Q13-Q14)) |
| Hy.n | -5 (hysteresis negative for output 1 terminals 21-22 (ex Q13-Q14)) |

Keep pushing **F** until you see **PASS**, release **F** and through the arrows set **99**, push **F** and visualize **Pro** (protection code) default is **12**, through the arrows set **128** and push **F**, keep it pushed until all parameters **InF**, **CFG**, **InP**, **Out**, **PASS** are visualized.

| CFG | |
|------------|------|
| S.tun | 0 |
| hPb | 1,2 |
| hIt | 5,83 |
| hdt | 1,33 |
| ... | |

| InP | |
|------------|---|
| | |
| tyP | 2 (thermocouple K 0÷1300°C) / 0 (thermocouple J 0÷1000°C) |
| ... | |
| dP_S | 0 (no decimal) / 1 (1 decimal) |
| Lo.S | 0 (min. sensor scale) |
| Hi.S | 1300 (max sensor scale for tc K) / 1000 (max sensor scale for tc J) |
| oFS | 0 (offset of input correction) |
| Lo.L | 0 (lower set-point range limit) |
| Hi.L | 1300 (upper set-point range limit) per tc K / 1000 for tc J |

| Out | |
|------------|--|
| A1.r | 0 |
| ... | |
| A1.t | 3 (mode AL1 =inverse-relative-normal) |
| ... | |
| rL.1 | 2 (AL1) |
| rL.2 | 18 (open) |
| rL.3 | 19 (close) |
| rEL | 0 |
| A.ty | 9 (type of servocontrol command) |
| Ac.t | 12 (servocontrol running time: SQN72.4.../STA12..=12; SQM40.265=30) |
| t Lo | 2 |
| t Hi | 0.0 |
| t.on | 2 |
| t.oF | 0.0 |
| dE.b | 0,1 (dead zone in % of end scale) |

| | |
|------------|---|
| PAS | 99 then push and keep pushed F until visualization of Hrd |
| ... | |
| Hrd | |
| ... | |
| Ctrl | 6 (PID warm) |
| AL.nr | 1 |
| but | 1 |
| diSP | 0 |
| Ld.1 | 1 |
| Ld.2 | 28 |
| Ld.3 | 20 |

Keep pushed **F** until you visualize **PASS**, release **F** and through the arrows set **99**, push **F** and visualize **Pro** (protection code) from **128**, through the arrows, bring it back to **12**, and keep **F** pushed until you come back to set-point value.

Manual operation:

Keep pushed the lower left key for at least 5 sec.

The instrument will enter the "MAN" mode (see also "Ld1" switching on).

Through the arrows, "Open" and "Close" outputs are activated.

To come back to normal working keep the lower left key pushed for at least 5 sec.

Software switch off :

By keeping pushed keys **Arrow up** + **F** for more than 5 sec. the instrument switches off the software, does not command the outputs and visualize only the variable of process measured by the probe.

To restore keep pushed **F** for more than 5 sec.

RWF50.2x & RWF50.3x



User manual

DEVICE INSTALLATION

Install the device using the relevant tools as shown in the figure.

To wire the device and sensors, follow the instructions on the burner wiring diagram.

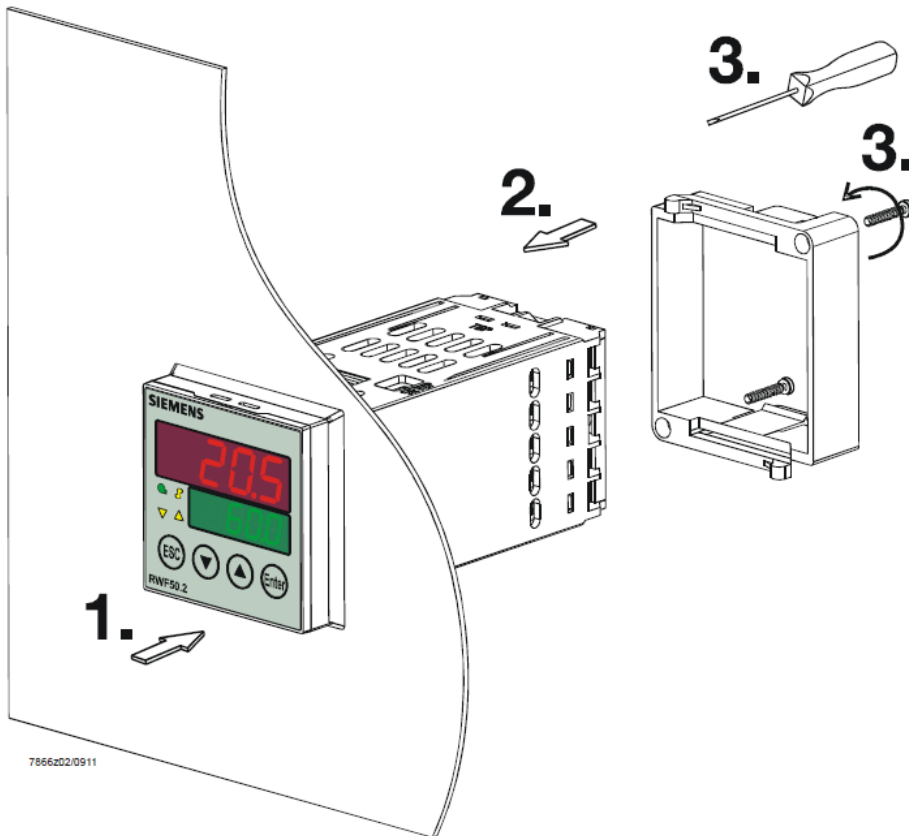

7866202/0911

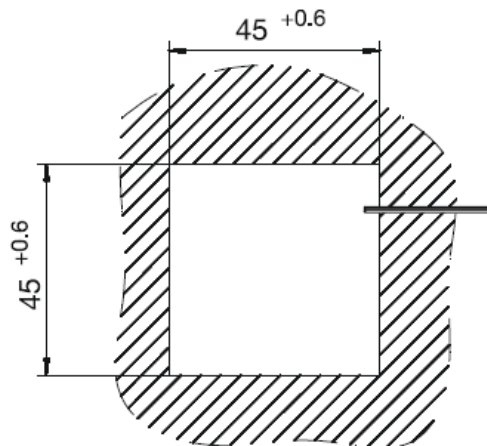

FRONT PANEL

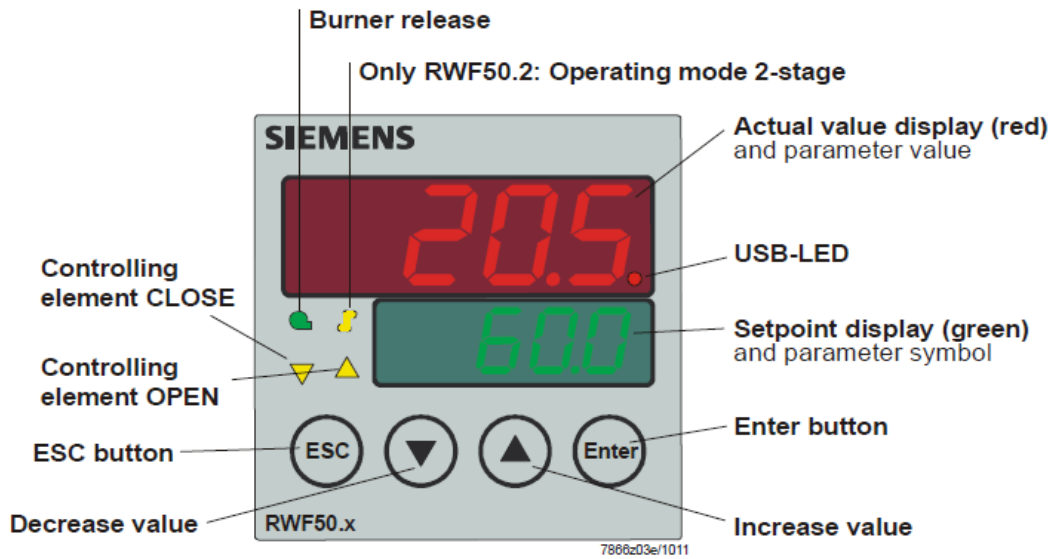

NAVIGATION MENU

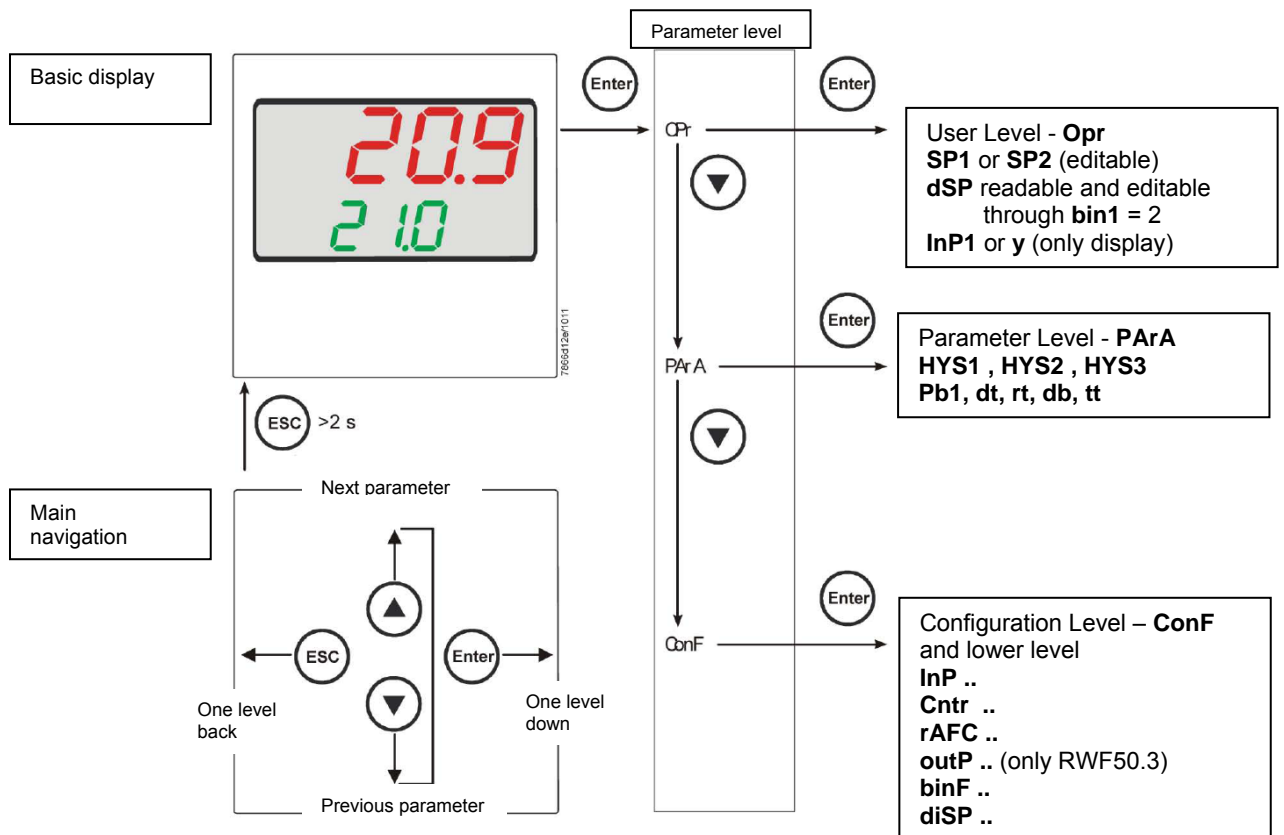

RWF5 is preset good for 90% of applications. However, you can set or edit parameters as follow:

Set-point: set or modification:

When the burner is in stand-by, (safety loop open, that is terminals 3-4/T1-T2 on the 7 pole plug open) push the **Enter** button: on the lower display (green) **Opr** appears; push **Enter** again and in the same display **SP1** appears. Push **Enter** again and the lower display (green **SP1**) flashes. Using the **up and down arrows** change the set-point on the upper display (red). Push **Enter** to confirm and push **ESC** more times to get the home position.

PID parameters set and modifications (see table below):

- Push **Enter** button, on the green display **Opr** appears; using the **down arrow**, scroll until group **PARA** is reached and push **Enter**.
- on the green display **Pb1** e appears and on the red one the set parameter.
- Push in sequence the **down or up** arrow the menu is scrolled.
- Push **Enter** to select and the **arrows** to choose the desired value. **Enter** to confirm.

| Parameter | Display | Range | Factory setting | Remarks |
|--|---------|--------------------|-----------------|---|
| Proportional band | PB.1 | 1... 9999 digit | 10 | Typical value for temperature |
| Derivative action | dt | 0... 9999 sec. | 80 | Typical value for temperature |
| Integral action | rt | 0... 9999 sec. | 350 | Typical value for temperature |
| Dead band (*) | db | 0... 999,9 digit | 1 | Typical value |
| Servocontrol running time | tt | 10... 3000 sec. | 15 | Set servocontrol running time |
| Switch-on differential (*) | HYS1 | 0,0... -1999 digit | -5 | Value under setpoint below which the burner switches back on (1N-1P closes) |
| Switch-off differential 2° stage (*) | HYS2 | 0,0 ... HYS3 | 3 | (enable only with parameter bin1 = 4) |
| Upper switch-off differential (*) | HYS3 | 0,0... 9999 digit | 5 | Value over setpoint above which the burner switches off (1N-1P opens) |
| Switch-on differential on cooling controller (*) | HYS4 | 0,0... 9999 digit | 5 | Do not used (enable only with parameter CACT = 0) |
| Switch-off differential 2° stage on cooling controller (*) | HYS5 | HYS6...0,0 digit | 5 | Do not used (enable only with parameters CACT = 0 and bin1 = 4) |
| Upper switch-off differential on cooling controller (*) | HYS6 | 0,0... -1999 digit | 5 | Do not used (enable only with parameter CACT = 0) |
| Delay modulation | q | 0,0... 999,9 digit | 0 | Do not alter |

(*)Parameters affected by setting of decimal place (**ConF > dISP** parameter **dECP**)

Setting the kind of sensor to be connected to the device:

- push the **Enter** button: on the lower display (green) **Opr** appears. Using the **up and down arrows** find **ConF**. Push **Enter** to confirm.
- Now on the green display the group **InP** appears. Push **Enter** and **InP1** is displayed. Enter to confirm.
- You are inside **InP1**; the green display shows **Sen1 (sensor type)**, while the red display shows the chosen sensor code
- Push **Enter** to enter the **Sen1** parameter, then choose the desired sensor using the **arrows**. Push **Enter** to confirm and **ESC** to escape.
- Once selected the sensor, you can modify all the other parameters using **up and down arrows** according to the tables here below.

ConF > InP > InP1

| Parameter | Value | Description |
|--|-----------------------------|---|
| SEn1 type of sensor for analog input 1 | 1 | Pt100 3 fili |
| | 2 | Pt100 2 fili |
| | 3 | Pt1000 3 fili |
| | 4 | Pt1000 2 fili |
| | 5 | Ni1000 3 fili |
| | 6 | Ni1000 2 fili |
| | 7 | 0 ÷ 135 ohm |
| | 15 | 0 ÷ 20mA |
| | 16 | 4 ÷ 20mA |
| | 17 | 0 ÷ 10V |
| | 18 | 0 ÷ 5V |
| 19 | 1 ÷ 5V | |
| OFF1 sensor offset | -1999.. 0 .. +9999 | Using the measured value correction (offset), a measured value can be corrected to a certain degree, either up or down |
| SCL1 scale low level | -1999.. 0 .. +9999 | In the case of a measuring transducer with standard signal, the physical signal is assigned a display value here (for input ohm, mA, V) |
| SCH1 scale high level | -1999.. 100 .. +9999 | In the case of a measuring transducer with standard signal, the physical signal is assigned a display value here (for input ohm, mA, V) |
| dF1 digital filter | 0.. 0,6 ...100 | Is used to adapt the digital 2nd order input filter (time in s; 0 s = filter off) |
| Unit temperature unit | 1 2 | 1 = degrees Celsius 2 = degrees Fahrenheit |

(**bold** = factory settings)

Remark:

RWF50.2 e RWF50.3 cannot be connected to thermocouples.
If thermocouples have to be connected, convert the signal to a 4-20 mA one and set the RWF accordingly.

ConF > Cntr

| Parameter | Value | Description |
|---|----------------------------|--|
| CtYP controller type | 1 2 | 1 = 3-position controller (open-stop-close only RWF50.2) 2 = continuative action controller (only RWF50.3) |
| CACt control action | 1 0 | 1 = heating controller 0 = cooling controller |
| SPL least value of the set-point range | -1999.. 0 ..+9999 | set-point limitation prevents entry of values outside the defined range |
| SPH maximum value of the set-point range | -1999.. 100 ..+9999 | set-point limitation prevents entry of values outside the defined range |
| oLLo set-point limitation start, operation limit low | -1999 +9999 | lower working range limit |
| oLHi set-point limitation end, operation limit high | -1999.... +9999 | upper working range limit |

(**bold** = factory settings)

ConF > rAFC

Activation boiler shock termic protetion:

RWF50.. can activate the thermal shock protection only on sites where the set-point is lower than 250°C and according to **rAL** parameter.

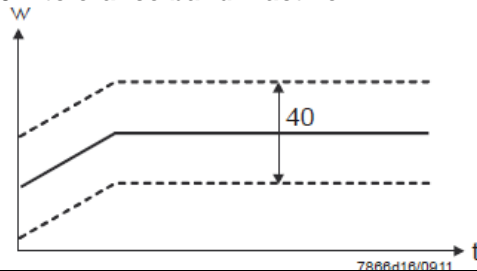
| Parameter | Value | Description |
|-----------------------------|----------------------|---|
| FnCT function | 0 1 2 | Choose type of range degrees/time 0 = deactivated 1 = Kelvin degrees/minute 2 = Kelvin degrees/hour |
| rASL ramp rate | 0,0 ... 999,9 | Slope of thermal shock protection (only with functions 1 and 2) |
| toLP tolerance band ramp | 0 ...9999 | width of tolerance band (in K) about the set-point 0 = tolerance band inactive  |
| rAL ramp limit | 0 ...250 | Ramp limit. When this value is lower than the temperature set-point, the RWF controls the output increasing the temp set point step by step according to rASL. If this is over the temp set point, the control is performed in cooling. |

(**bold** = factory settings)

ConF > OutP (parameter under group only for RWF50.3)

| Parameter | Value | Description |
|---------------------------------------|-----------------------------|--|
| FnCt tipo di controllo | 1 4 | 1 = analog input 1 doubling with possibility to convert (depending on par SiGn) 4 = modulation controller |
| SiGn type of output signal | 0 1 2 | physical output signal (terminals A+, A-) 0 = 0÷20mA 1 = 4÷20mA 2 = 0÷10V |
| rOut Value when out of input range | 0...101 | signal (in percent) when measurement range is crossed |
| oPnt zero point | -1999... 0 ..+9999 | value range of the output variable is assigned to a physical output signal Per default, the setting corresponds to 0...100% angular positioning for the controller outputs (terminals A+, A-) (effective only with FnCt = 1) |
| End End value | -1999... 100 ..+9999 | value range of the output variable is assigned to a physical output signal Per default, the setting corresponds to 0...100% angular positioning for the controller outputs (terminals A+, A-) (effective only with FnCt = 1) |

(**bold** = factory settings)

ConF > binF

| Parameter | Value | Description |
|---|-------------------------|---|
| bin1 digital inputs (terminals DG - D1) | 0 1 2 4 | 0 = without function 1 = set-point changeover (SP1 / SP2) 2 = set-point shift (Opr > dSP parameter = value of set-point modify) 4 = changeover of operating mode open – modulating operation; close – 2 stage operation. |

(**bold** = factory settings)

ConF > dISP

| Parameter | Value | Description |
|----------------------------------|------------------------------|--|
| diSU upper display (red) | 0 1 4 6 7 | display value for upper display: 0 = display power-off 1 = analog input value 4 = Controller's angular positioning 6 = set-point value 7 = end value with thermal shock protection |
| diSL lower display (green) | 0 1 4 6 7 | display value for lower display: 0 = display power-off 1 = analog input value 4 = Controller's angular positioning 6 = set-point value 7 = end value with thermal shock protection |
| tout timeout | 0.. 180 ..250 | time (s) on completion of which the controller returns automatically to the basic display, if no button is pressed |
| dECP decimal point | 0 1 2 | 0 = no decimal place 1 = one decimal place 2 = two decimal places |
| CodE level lockout | 0 1 2 3 | 0 = no lockout 1 = configuration level lockout (ConF) 2 = Parameter and configuration level lockout (PARa & ConF) 3 = keyboard lockout |

(**bold** = factory settings)

Manual control :

- in order to manual change the burner load, while firing keep pushing the **ESC** button for more than 5 s; on the lower green display **Hand** appears.
- using the **UP** and **DOWN** arrows, the load varies.
- Keep pushing the **ESC** button for getting the normal operation again.
- **NB:** every time the device shuts the burner down (start led switched off - contact 1N-1P open), the manual control is not active.

Device self-setting (auto-tuning):

If the burner in the steady state does not respond properly to heat generator requests, you can activate the Device's self-setting function, which recalculates PID values for its operation, deciding which are most suitable for the specific kind of request

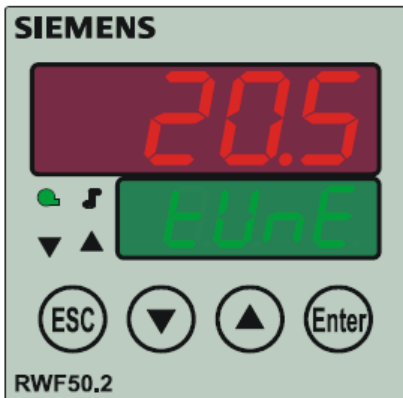

Follow the below instructions:
push the **UP** and **DOWN** arrows for more than 5 s; on the green lower display **TUNE** appears. Now the device pushes the burner to increase and decrease its output. During this time, the device calculates PID parameters (**Pb1**, **dt** and **rt**). After the calculations, the TUNE is automatically deactivated and the device has already stored them.
In order to stop the Auto-tuning function while it works, push again the **UP** and **DOWN** arrows for more than 5 s. The calculated PID parameters can be manually modified following the previously described instructions.

Display of software version :



The software version is shown by pushing **Enter + UP arrow** on the upper display

Electric connection :

With 7 pins connector version

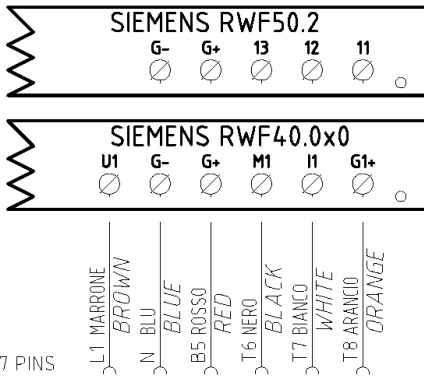

CONN. 7 PINS

With terminals version

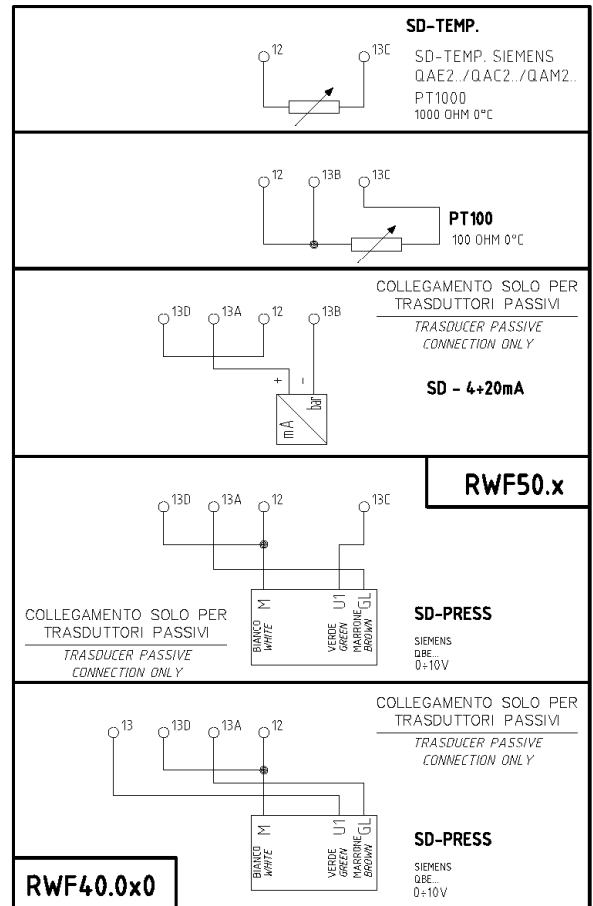
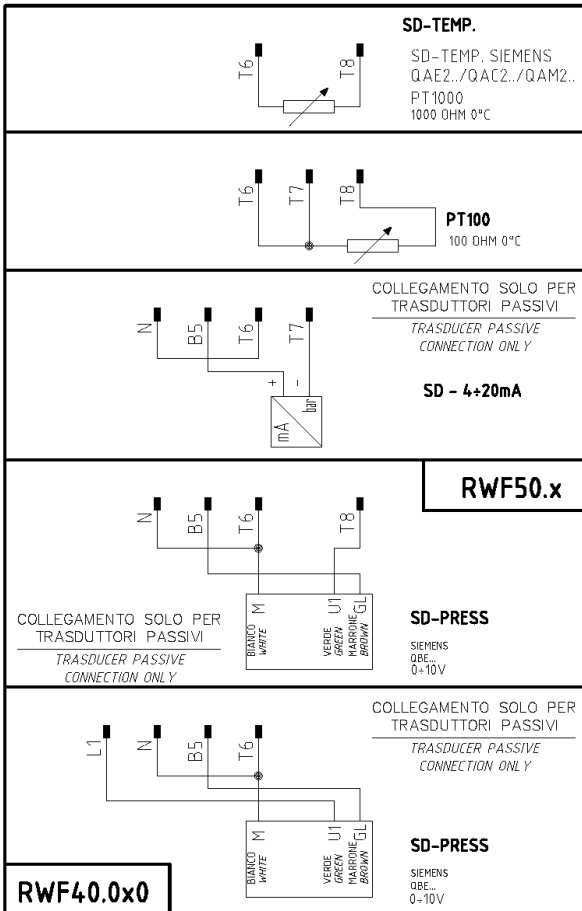
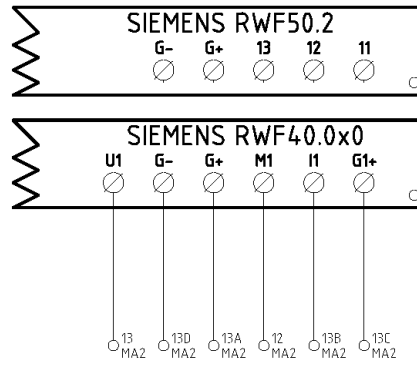

Matches terminals between RWF50.2 and RWF40.0x0

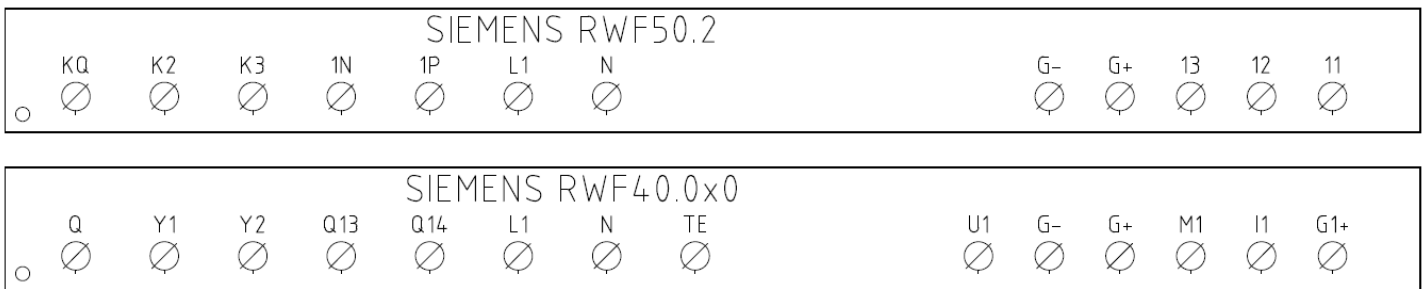

Parameters summarising for RWF50.2x:

| Navigation menù | Conf Inp | | | | | Conf | | | PArA | | | | | Opr | |
|-------------------------|----------|------|-------------|-------------|----------|-------------|-------------|-------------|-------|----|---------|----|-------------|-------------|-------------|
| | Inp1 | | | | | Cntr | | diSP | | | | | | | |
| Types of probe | SEn1 | OFF1 | SCL | SCH | Unit | SPL | SPH | dECP | Pb. 1 | dt | rt | tt | HYS1 (*) | HYS3 (*) | SP1 (*) |
| Siemens QAE2120... | 6 | 0 | needless | needless | 1 | 30 | 95 | 1 | 10 | 80 | 350 (#) | | -5 | 5 | 80 °C |
| Siemens QAM2120.. | 6 | 0 | needless | needless | 1 | 0 | 80 | 1 | 10 | 80 | 350 (#) | | -2.5 | 2.5 | 40°C |
| Pt1000 (130°C max.) | 4 | 0 | needless | needless | 1 | 30 | 95 | 1 | 10 | 80 | 350 (#) | | -5 | 5 | 80°C |
| Pt1000 (350°C max.) | 4 | 0 | needless | needless | 1 | 0 | 350 | 1 | 10 | 80 | 350 (#) | | -5 | 10 | 80°C |
| Pt100 (130°C max.) | 1 | 0 | needless | needless | 1 | 0 | 95 | 1 | 10 | 80 | 350 (#) | | -5 | 5 | 80°C |
| Pt100 (350°C max) | 1 | 0 | needless | needless | 1 | 0 | 350 | 1 | 10 | 80 | 350 (#) | | -5 | 10 | 80°C |
| Sonda 4÷20mA / 0÷1,6bar | 16 | 0 | 0 | 160 | needless | 0 | 160 | 0 | 5 | 20 | 80 (#) | | 0 | 20 | 100 kPa |
| Sonda 4÷20mA / 0÷10bar | 16 | 0 | 0 | 1000 | needless | 0 | 1000 | 0 | 5 | 20 | 80 (#) | | 0 | 50 | 600 kPa |
| Sonda 4÷20mA / 0÷16bar | 16 | 0 | 0 | 1600 | needless | 0 | 1600 | 0 | 5 | 20 | 80 (#) | | 0 | 80 | 600 kPa |
| Sonda 4÷20mA / 0÷25bar | 16 | 0 | 0 | 2500 | needless | 0 | 2500 | 0 | 5 | 20 | 80 (#) | | 0 | 125 | 600 kPa |
| Sonda 4÷20mA / 0÷40bar | 16 | 0 | 0 | 4000 | needless | 0 | 4000 | 0 | 5 | 20 | 80 (#) | | 0 | 200 | 600 kPa |
| Sonda 4÷20mA / 0÷60PSI | 16 | 0 | 0 | 600 | needless | 0 | 600 | 0 | 5 | 20 | 80 (#) | | 0 | 30 | 300 (30PSI) |
| Sonda 4÷20mA / 0÷200PSI | 16 | 0 | 0 | 2000 | needless | 0 | 2000 | 0 | 5 | 20 | 80 (#) | | 0 | 75 | 600 (60PSI) |
| Sonda 4÷20mA / 0÷300PSI | 16 | 0 | 0 | 3000 | needless | 0 | 3000 | 0 | 5 | 20 | 80 (#) | | 0 | 120 | 600 (60PSI) |
| Siemens QBE2002 P4 | 17 | 0 | 0 | 400 | needless | 0 | 400 | 0 | 5 | 20 | 80 (#) | | 0 | 20 | 200 kPa |
| Siemens QBE2002 P10 | 17 | 0 | 0 | 1000 | needless | 0 | 1000 | 0 | 5 | 20 | 80 (#) | | 0 | 50 | 600 kPa |
| Siemens QBE2002 P16 | 17 | 0 | 0 | 1600 | needless | 0 | 1600 | 0 | 5 | 20 | 80 (#) | | 0 | 80 | 600 kPa |
| Siemens QBE2002 P25 | 17 | 0 | 0 | 2500 | needless | 0 | 2500 | 0 | 5 | 20 | 80 (#) | | 0 | 125 | 600 kPa |
| Siemens QBE2002 P40 | 17 | 0 | 0 | 4000 | needless | 0 | 4000 | 0 | 5 | 20 | 80 (#) | | 0 | 200 | 600 kPa |
| Segnale 0÷10V | 17 | 0 | to be fixed | to be fixed | needless | to be fixed | to be fixed | to be fixed | 5 | 20 | 80 (#) | | to be fixed | to be fixed | to be fixed |
| Segnale 4÷20mA | 16 | 0 | to be fixed | to be fixed | needless | to be fixed | to be fixed | to be fixed | 5 | 20 | 80 (#) | | to be fixed | to be fixed | to be fixed |

NOTE : (#) tt - Types of probe

SQL33 ; STM30; SQM10; SQM40; SQM50; SQM54 = 30 (second) - STA12B3.41; SQN30.251; SQN72.4A4A20 = 12 (second)

(*) These values are factory set - values **MUST BE** set during operation at the plant based on the real working temperature/pressure value.

WARNING : With pressure probes the parameters SP1, SCH, SCL, HYS1, HYS3 must be selected, and visualized in kPa (kilo Pascal). (1bar = 100.000Pa = 100kPa).

TABLE OF PARAMETERS TO BE MODIFIED FOR CALIBRATIONS RWF50.3x/RWF55.xx (CONTINUOUS OUTPUT 4÷20mA) INSTEAD OF 3 POINTS

| Navigation menù | Conf OutP | | | | |
|-----------------|-----------|------------|------|------|-----|
| Parameter | FnCt | SiGn | rOut | OPnt | End |
| | 4 | 1 (4÷20mA) | 0 | 0 | 100 |

NOTE : (#) tt - servocontrol travel time

SQL33 ; STM30; SQM10; SQM40; SQM50; SQM54 = 30 (second)

STA12B3.41; SQN30.251; SQN72.4A4A20 = 12 (second)

(*) Factory-set values, these values must be varied according to the actual working temperature/pressure of the system.

WARNING : With pressure probes in bar, parameters SP1, SCH, SCL, HYS1, HYS3 must be set, and displayed in kPa (kilo Pascal); 1bar = 100,000Pa = 100kPa.
With pressure probes in PSI the parameters SP1, SCH, SCL, HYS1, HYS3 must be set, and displayed in PSI x10 (example : 150PSI > display 1500).

APPENDIX: PROBES CONNECTION

To assure the utmost comfort, the control system needs reliable information, which can be obtained provided the sensors have been installed correctly. Sensors measure and transmit all variations encountered at their location.

Measurement is taken based on design features (time constant) and according to specific operating conditions. With wiring run in raceways, the sheath (or pipe) containing the wires must be plugged at the sensor's terminal board so that currents of air cannot affect the sensor's measurements.

Ambient probes (or ambient thermostats)

Installation

The sensors (or room thermostats) must be located in reference rooms in a position where they can take real temperature measurements without being affected by foreign factors.

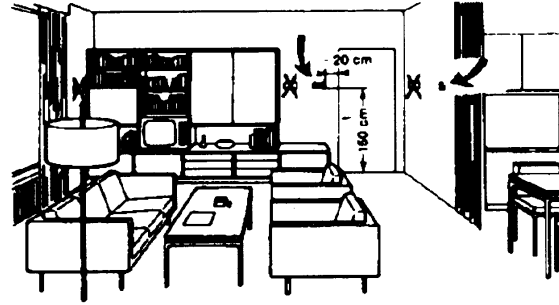
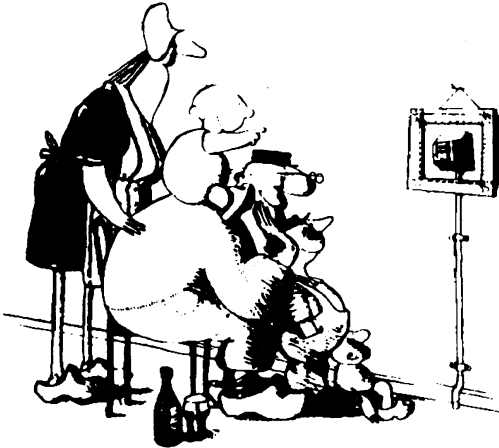

Outside probes (weather)

Installation

In heating or air-conditioning systems featuring adjustment in response to outside temperature, the sensor's positioning is of paramount importance.

It's good to be admired ...even better to be effective

Heating systems: the room sensor must not be installed in rooms with heating units complete with thermostatic valves. Avoid all sources of heat foreign to the system.

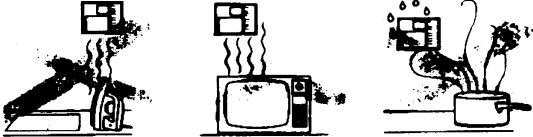

General rule: on the outer wall of the building where the living rooms are, never on the south-facing wall or in a position where they will be affected by morning sun. If in any doubt, place them on the north or north-east façade.

Location

On an inner wall on the other side of the room to heating units height above floor 1.5 m, at least 1.5 m away from external sources of heat (or cold).

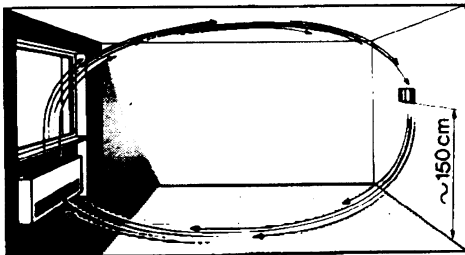

Installation position to be avoided

near shelving or alcoves and recesses, near doors or windows, inside outer walls exposed to solar radiation or currents of cold air, on inner walls with heating system pipes, domestic hot water pipes, or cooling system pipes running through them.

Positions to be avoided

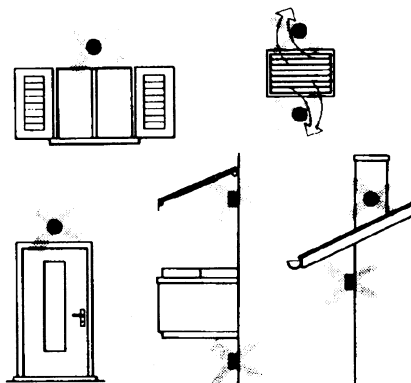

Avoid installing near windows, vents, outside the boiler room, on chimney breasts or where they are protected by balconies, cantilever roofs.

The sensor must not be painted (measurement error).

Duct or pipe sensors

Installing temperature sensors

For measuring outlet air:

- after delivery fan or
- after coil to be controlled, at a distance of at least 0,5 m

For measuring room temperature:

- before return air intake fan and near room's return airintake. For measuring saturation temperature: after mist eliminator.

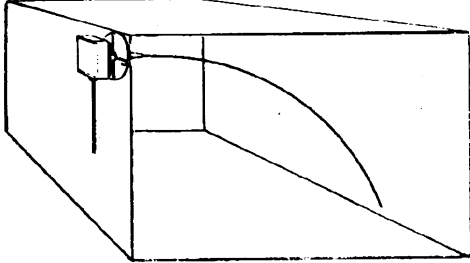

Bend 0.4m sensor by hand (never use tools) as illustrated.

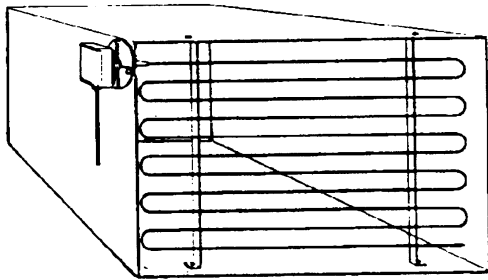

Use whole cross-section of duct, min. distance from walls 50 mm, radius of curvature 10 mm for 2m or 6m sensors.

Installing combined humidity sensors

As max. humidity limit sensor on outlet (steam humidifiers).

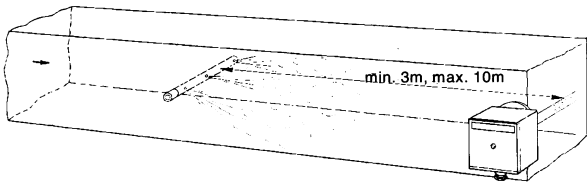

Installing pressure sensors

A - installation on ducts carrying fluids at max. temperature 80°C

B - installation on ducts at temperature over 80°C and for refrigerants

C - installation on ducts at high temperatures:

- increase length of siphon
- place sensor at side to prevent it being hit by hot air coming from the pipe.

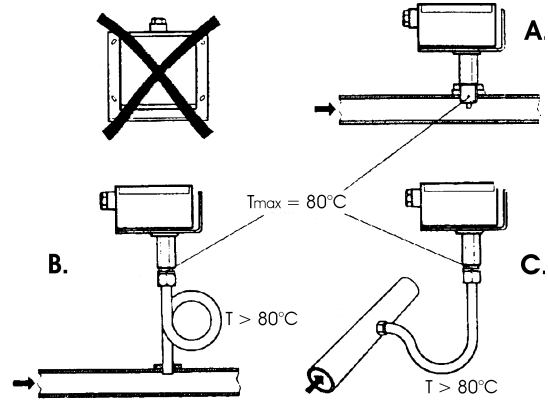

Installing differential pressure sensors for water

- Installation with casing facing down not allowed.-With temperature over 80°C, siphons are needed.
- To avoid damaging the sensor, you must comply with the following instructions

when installing:

- make sure pressure difference is not greater than thevalue permitted by the sensor
- when there are high static pressures, make sure you insert shutoff valves A-B-C.

Putting into operation

Start disable

1=open C1=open C

2=open A2=close B

3=open B3=close A

4= close C

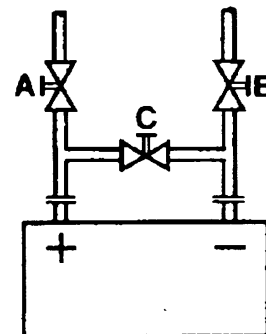

Immersion or strap-on sensors

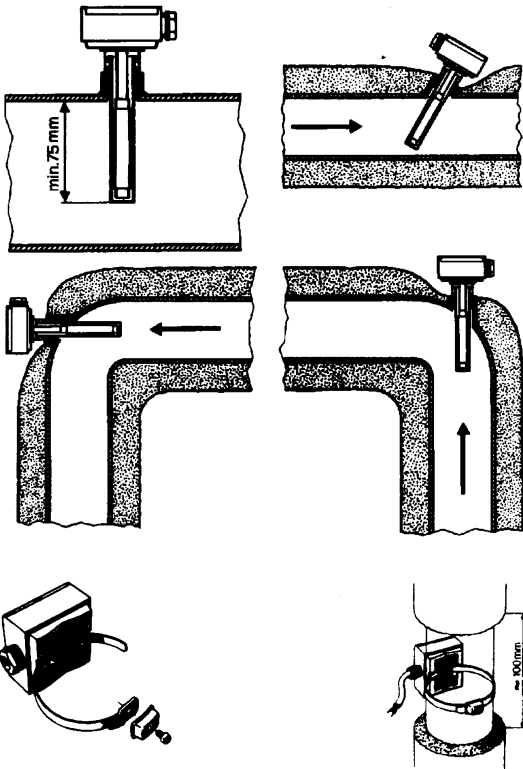

Immersion probes installation

Sensors must be installed on the stretch of pipe in which fluid circulates all the time.

The rigid stem (sensing element doing the measuring) must be inserted by at least 75mm and must face the direction of flow.

Recommended locations: on a bend or on a straight stretch of pipe but tilted by 45° and against the flow of fluid.

Protect them to prevent water from infiltrating (dripping gates, condensation from pipes etc.)

Installing QAD2.. strap-on sensors

Make sure fluid is circulating in the chosen location.

Eliminate insulation and paintwork (including rust inhibitor) on a min. 100mm length of pipe.

Sensors come with straps for pipes up to 100 mm in diameter

Placing the probes (QAD22.../QAE21.../QAP21.../RCA...)

With pumps on outlet

with 3 ways valves / with 4 ways valves



Panel system / burner control

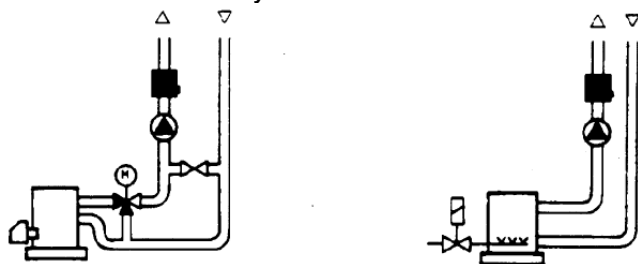

Strap-on or immersion sensors?

QAD2.. strap-on sensors

Advantages :

- 10 sec. time constant
- Installed with system running (no plumbing work)
- Installation can be changed easily if it proves incorrect.

Limits:

- Suitable for pipe diameters max. 100 mm
- Can be affected by currents of air etc.

QAE2... immersion sensors

Advantages:

- Measure "mean" fluid temperature
- No external influence on measurement such as: currents of air, nearby pipes etc.

Limits:

- Time constant with sheath: 20 sec.
- Hard to change installation position if it proves incorrect.

With pumps on return

with 3 ways valves / with 4 ways valves



Duct pressure switches and sensors

Installing differential pressure probes for air

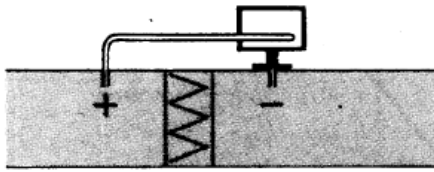

A - Control a filter (clogging)

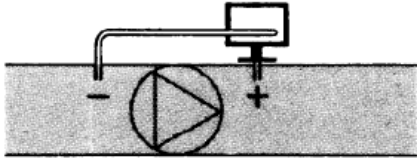

B - Control a fan (upstream/downstream)

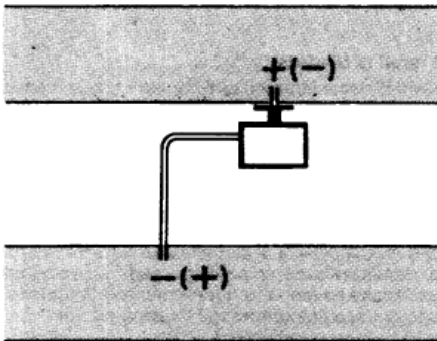

C - Measurement of difference in pressure between two ducts

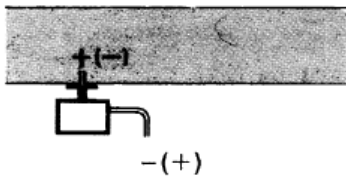

D - Measurement of difference in pressure between two rooms or of inside of duct and outside

Basic principles

Measuring static pressure (i.e. pressure exerted by air on pipe walls)

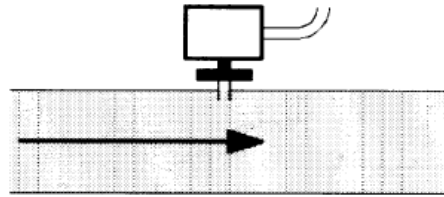

Measuring dynamic pressure

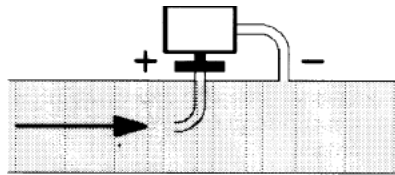

$$Pd = \frac{\gamma v^2}{2g}$$

Key

- γ Kg/m³, specific weight of air
- v m/s, air speed
- g 9.81 m/s² gravity acceleration
- Pd mm C.A., dynamic pressure

Measuring total pressure

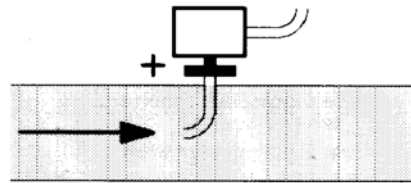

Spare parts

| Description | Code |
|--|---------|
| Modulator RWF50.2 (uscita a 3 punti - apri, fermo, chiudi) 2570148 | 2570148 |
| Modulator RWF50.3 (uscita continua 0÷20mA, 4÷20mA, 0÷10V) 2570149 | 2570149 |
| Temperature probe Siemens QAE2120.010A (30÷130°C) 2560101 | 2560101 |
| Temperature probe Siemens QAM2120.040 (-15÷+50°C) 2560135 | 2560135 |
| Thermoresistor Pt1000 ø6mm L100mm (30÷130°C) 2560188 | 2560188 |
| Thermoresistor Pt1000 ø10mm L200mm (0÷350°C) 2560103 | 2560103 |
| Thermoresistor Pt100 ø10mm L200mm (0÷350°C) 2560145 | 2560145 |
| Thermoresistor Pt100 ø8mm L85mm (0÷120°C) 25601C3 | 25601C3 |
| Pressure probe Siemens QBE2.. P4 (0÷4bar) 2560159 | 2560159 |
| Pressure probe Siemens QBE2.. P10 (0÷10bar / signal 0÷10V) 2560160 | 2560160 |
| Pressure probe Siemens QBE2.. P16 (0÷16bar / signal 0÷10V) 2560167 | 2560167 |
| Pressure probe Siemens QBE2.. P25 (0÷25bar / signal 0÷10V) 2560161 | 2560161 |
| Pressure probe Siemens QBE2.. P40 (0÷40bar / signal 0÷10V) 2560162 | 2560162 |
| Pressure probe Danfoss MBS 3200 P 1,6 (0÷1,6bar / signal 4÷20mA) 2560189 | 2560189 |
| Pressure probe Danfoss MBS 3200 P 10 (0÷10bar / signal 4÷20mA) 2560190 | 2560190 |
| Pressure probe Danfoss MBS 3200 P 16 (0÷16bar / signal 4÷20mA) 2560191 | 2560191 |
| Pressure probe Danfoss MBS 3200 P 25 (0÷25bar / signal 4÷20mA) 2560192 | 2560192 |
| Pressure probe Danfoss MBS 3200 P 40 (0÷40bar / signal 4÷20mA) 2560193 | 2560193 |
| Pressure probe Siemens 7MF1565-3BB00-1AA1 (0÷1,6bar / signal 4÷20mA) 25601A3 | 25601A3 |
| Pressure probe Siemens 7MF1565-3CA00-1AA1 (0÷10bar / signal 4÷20mA) 25601A4 | 25601A4 |
| Sonda di pressione Siemens 7MF1565-3CB00-1AA1 (0÷16bar / signal 25601A5 | 25601A5 |
| Pressure probe Siemens 7MF1565-3CD00-1AA1 (0÷25bar / signal 4÷20mA) 25601A6 | 25601A6 |
| Pressure probe Siemens 7MF1565-3CE00-1AA1 (0÷40bar / signal 4÷20mA) 25601A7 | 25601A7 |
| Pressure probe Gefran E3E B1V6 MV (0÷1,6bar / segnale 4÷20mA) 25601C4 | 25601C4 |
| Pressure probe Danfoss E3E B01D MV (0÷10bar / segnale 4÷20mA) 25601C5 | 25601C5 |
| Pressure probe Danfoss E3E B16U MV (0÷16bar / segnale 4÷20mA) 25601C6 | 25601C6 |
| Pressure probe Danfoss E3E B25U MV (0÷25bar / segnale 4÷20mA) 25601C7 | 25601C7 |
| Pressure probe Danfoss E3E B04D MV (0÷40bar / segnale 4÷20mA) 25601C8 | 25601C8 |
| Pressure probe Siemens 7MF1567-4CD00-1EA1 (0-300PSI 1/4NPT 4-20mA) | 25601G0 |
| Pressure probe Siemens 7MF1567-4BF00-1EA1 (0-60PSI 1/4NPT 4-20mA) | 25601G1 |
| Pressure probe Siemens 7MF1567-4CB00-1EA1 (0-200PSI 1/4NPT 4-20mA) | 25601G2 |

Note: Specifications and data subject to change. Errors and omissions excepted.

KM3 Modulator

USER MANUAL

MOUNTING

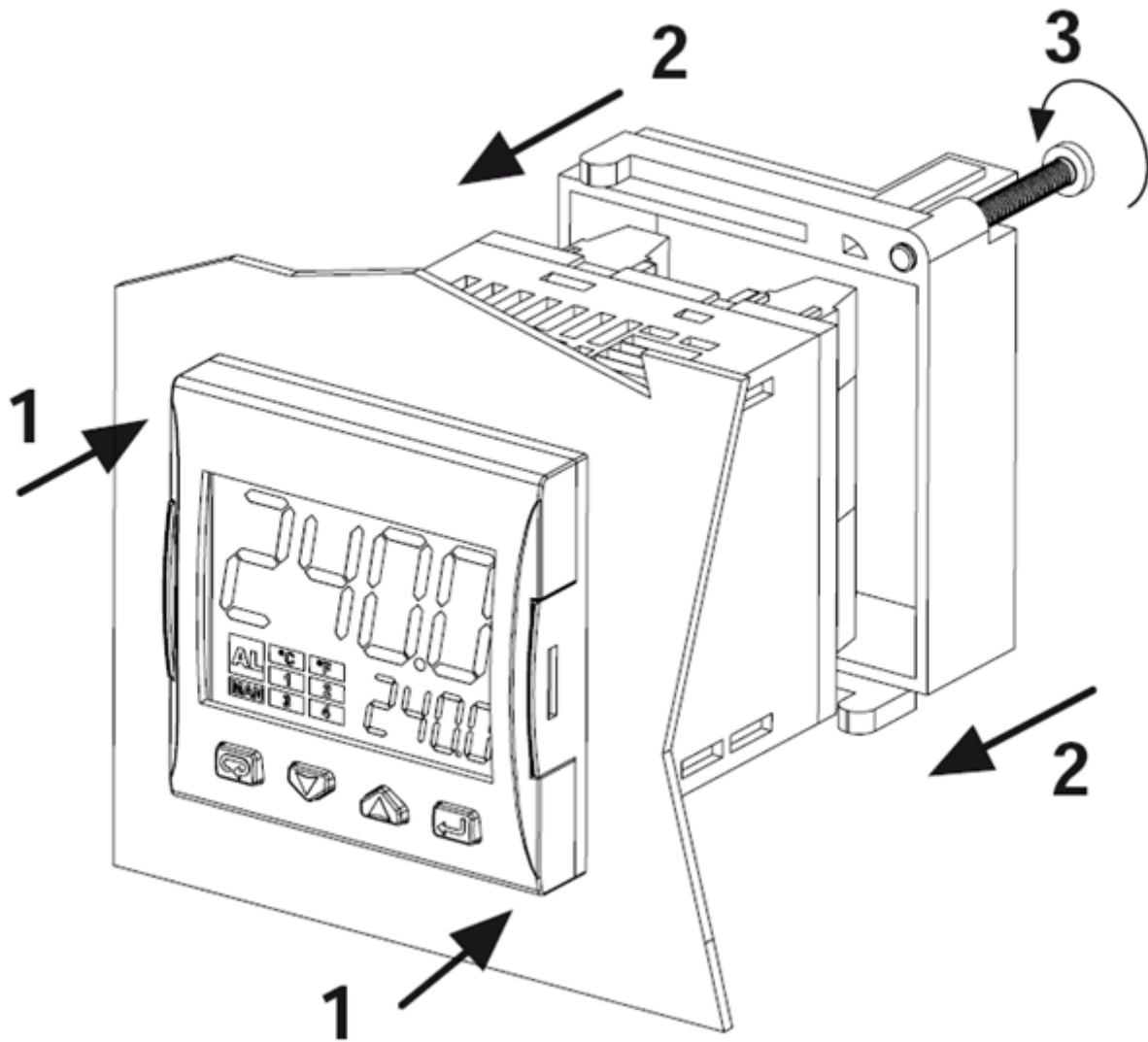

DISPLAY AND KEYS

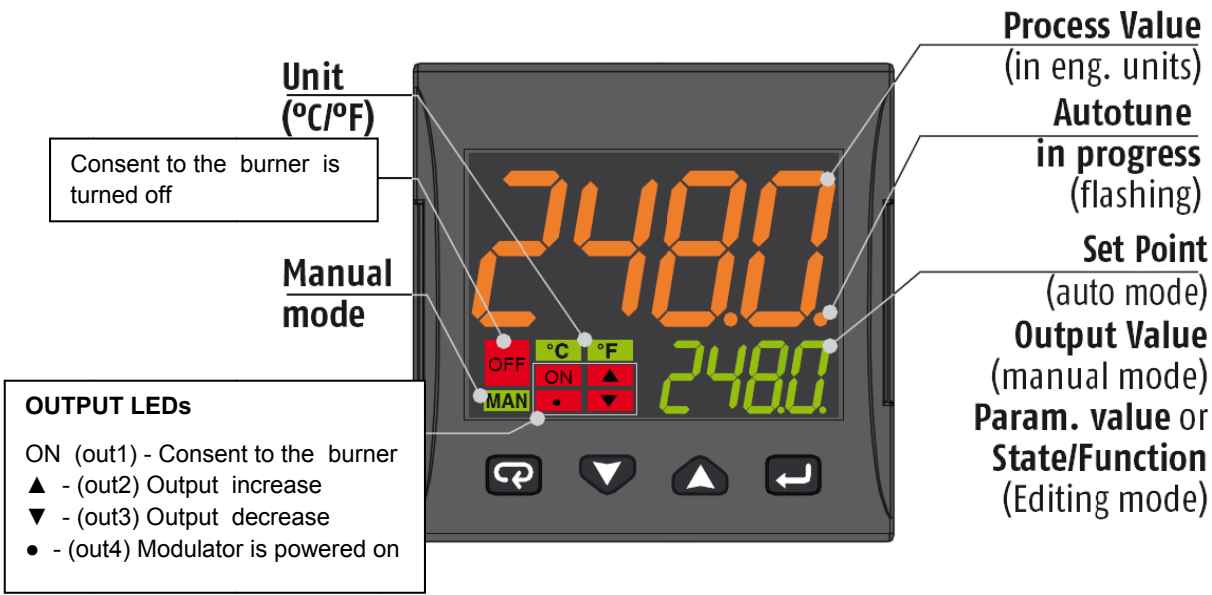

| | Operator Mode | Editing Mode |
|--|---|---|
| | Access to: - Operator Commands (Timer, Setpoint selection ...) - Parameters - Configuration | Confirm and go to Next parameter |
| | Access to: - Operator additional information (Output value, running time ...) | Increase the displayed value or select the next element of the parameters list |
| | Access to: - Set Point | Decrease the displayed value or select the previous element |
| | Programmable key: Start the programmed function (Autotune, Auto/Man, Timer ...) | Exit from Operator commands/Parameter setting/Configuration |

CONNECTIONS DIAGRAM

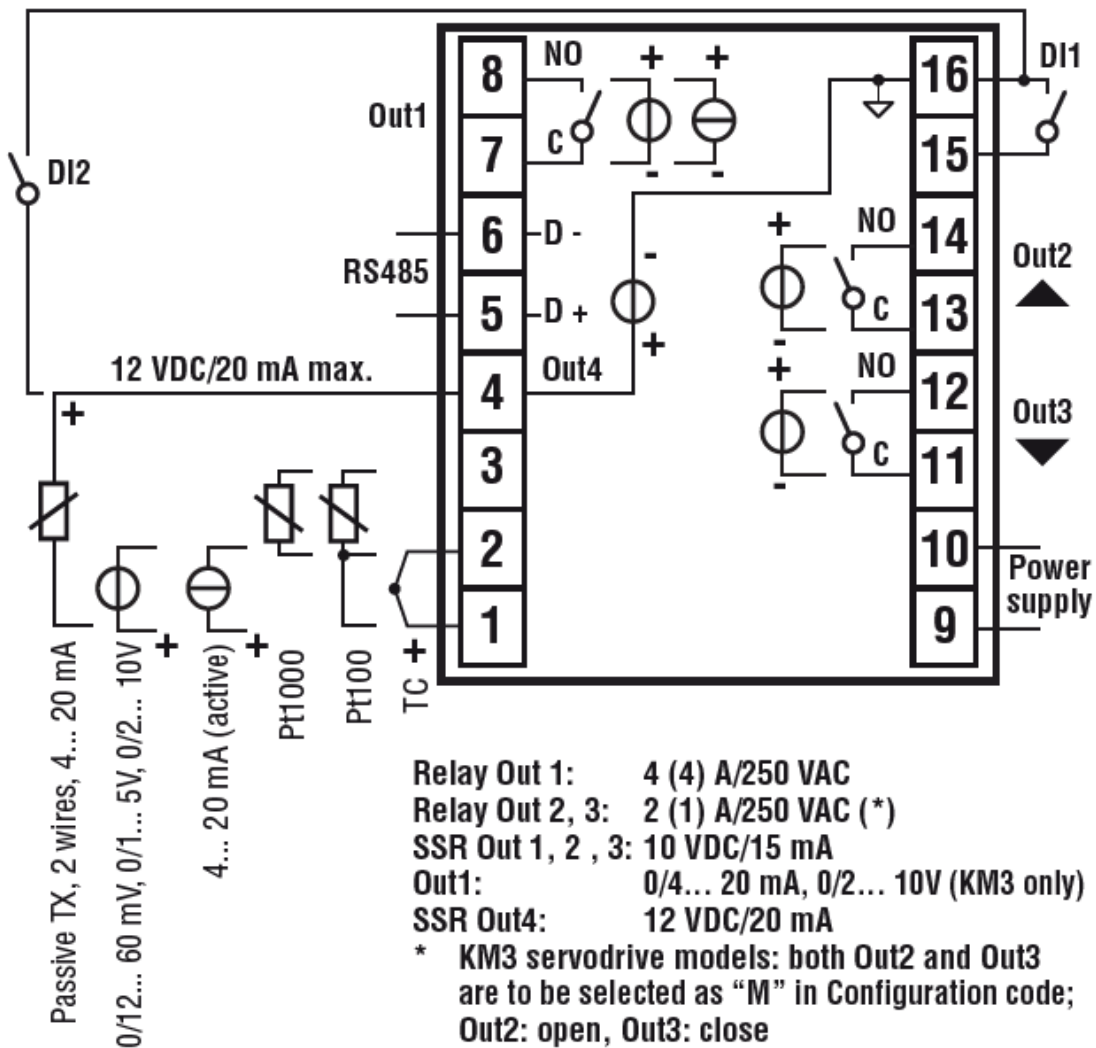

Probe connection:

- **PT1000/NTC/PTC:** between terminal 3 and 2
- **PT 100:** between terminal 3 and 2 with terminal 1
- **Passive pressure probe** 0/4-20 mA: between terminal 4 (+) e 1 (-)
Note: out4 must be activated (IO4F must be setted to ON)
- **Powered pressure probe** 0/4-20 mA between terminal 4 (power supply), 2 (negative) e 1 (positive)
Note: set IO4F to ON to activate Out4

Power supply connection:

- **Neutral wire:** terminal 9
- **Phase:** terminal 10 (100...240 Vac)
- Close terminals 15-16 to switch to the set point 2

Output connection:

- **Channel 1:** terminal 7 and 8 (burner on – off)
- **Channel 2:** terminal 11 and 12 (servomotor opens)
- **Channel 3:** terminal 13 and 14 (servomotor closes)

SETPOINT AND HYSTERESIS CONFIGURATION (SP, AL1, HAL1 parameters)

Push the  button to enter into the setpoint configuration:

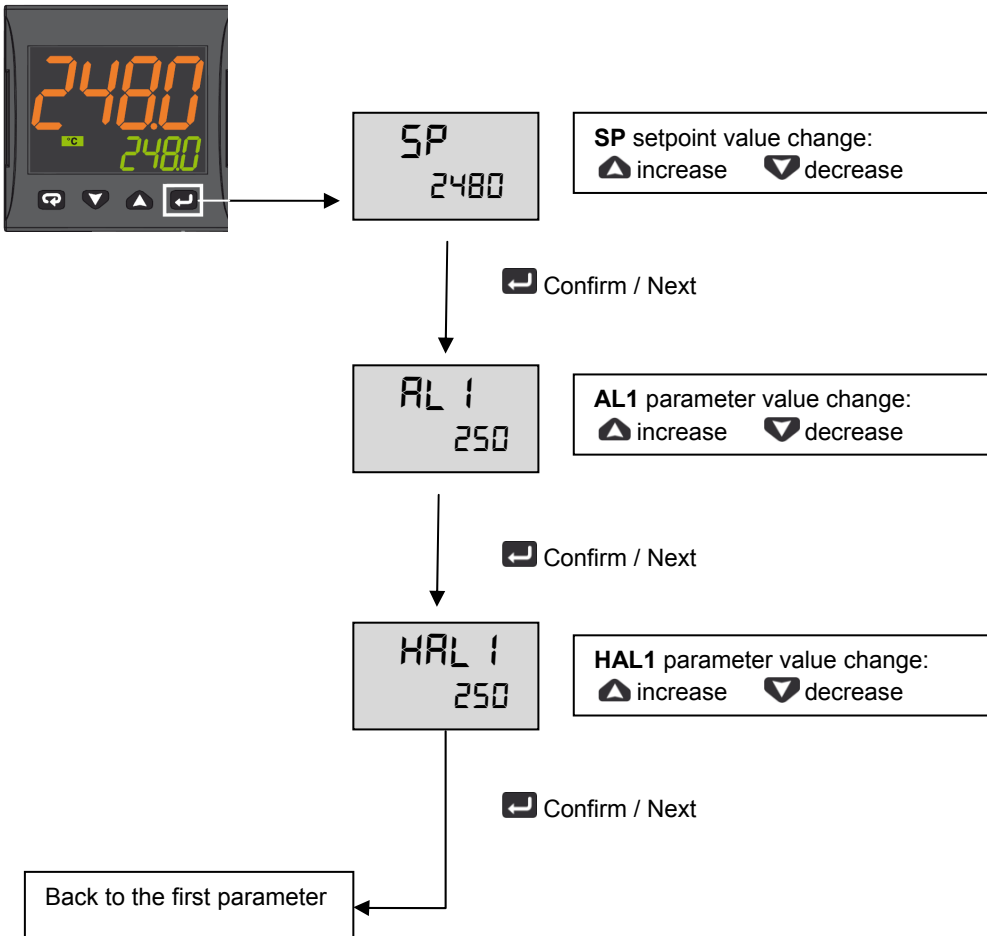

To return to normal mode, press the  key for 3 seconds or wait the 10s timeout

Operation example

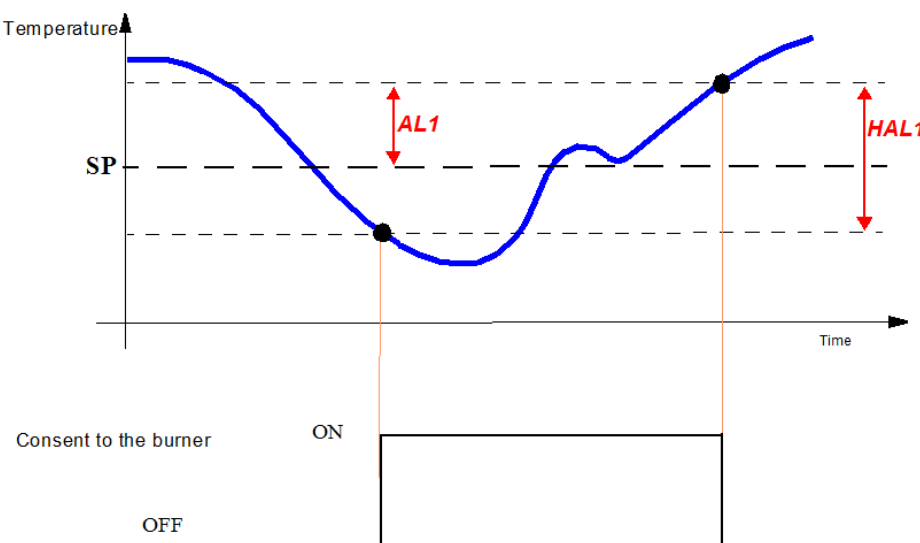

LIMITED ACCESS LEVEL

Proceed as follows to change some parameters that are not visible in standard user mode:

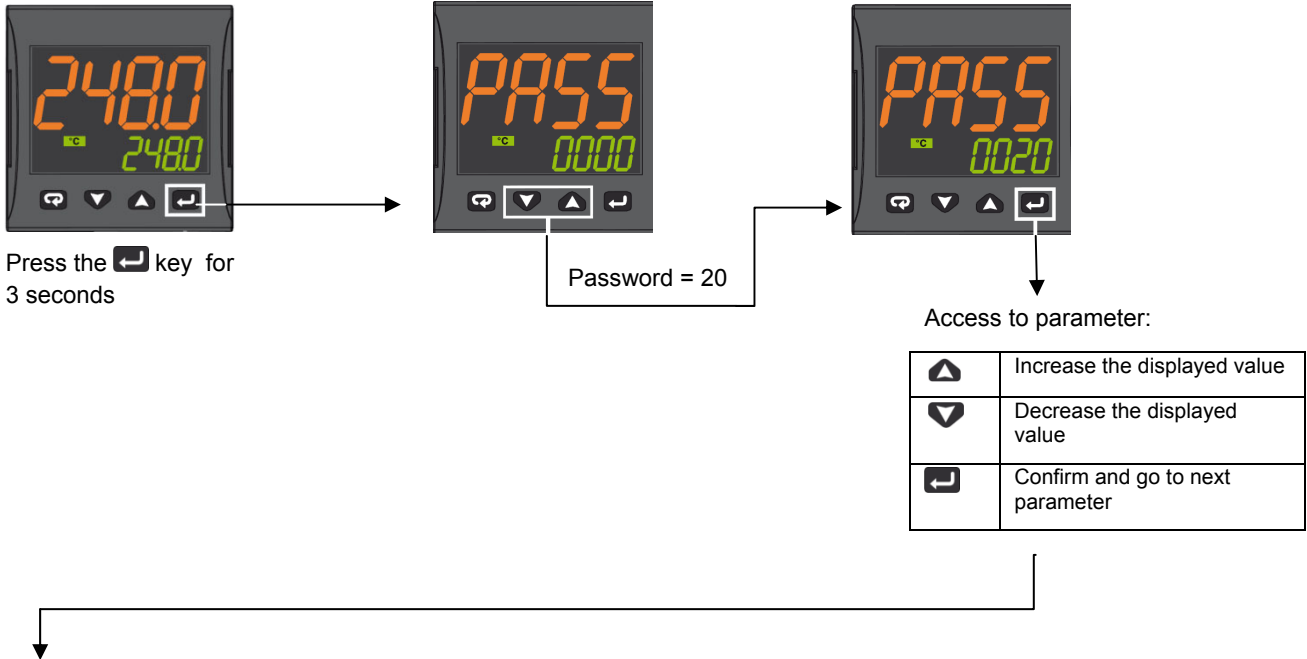

| Param | Description | Values | Default |
|-------|-----------------------------------|---|----------------------|
| SEnS | Input type | Pt1 = RTD Pt100 Pt10 = RTD Pt1000 0.20 = 0..20mA 4.20 = 4..20mA Pressure probe 0.10 = 0..10V 2.10 = 2..10V crAL= Thermocouple K | Depends on the probe |
| SP | Set point 1 | SPLL ... SPLH | See page 7 |
| AL1 | AL1 threshold | AL1L... AL1H (E.U.) | |
| HAL1 | AL1 hysteresis | 1... 9999 (E.U.) | |
| Pb | Proportional band | 1... 9999 (E.U.) | |
| ti | Integral time | 0 (oFF) ... 9999 (s) | |
| td | Derivative time | 0 (oFF) ... 9999 (s) | |
| Str.t | Servomotor stroke time | 5...1000 seconds | |
| db.S | Servomotor dead band | 0...100% | |
| SPLL | Minimum set point value | -1999 ... SPLH | |
| SPLH | Maximum set point value | SPLL ... 9999 | |
| dp | Decimal point position | 0... 3 | |
| SP 2 | Set point 2 | SPLL...SPLH | 60 |
| A.SP | Selection of the active set point | "SP" ... "nSP" | SP |

To exit the parameter setting procedure press the key (for 3 s) or wait until the timeout expiration (about 30 seconds)

Probe parameters configuration MODULATORE ASCON KM3

| Parameter Group | inP | | | | AL1 | | | | rEG | | | | SP | | | |
|----------------------------------|------|-----------|-----------|-----------|------|------------|-----------|------------|----------|----------|----------|--------------|----------|--------|--------|-----------|
| | Sens | dp | SSC | FSc | unit | IO4.F (**) | AL1 (***) | HAL1 (***) | Pb (***) | ti (***) | td (***) | Str.t | db.S | SPLL | SPHL | SP (***) |
| Probes | | Dec Point | Scale Min | Scale Max | | | Off | On | p | i | d | servo time s | Band Mo. | SP Min | SP Max | Set point |
| Pt1000 (130°C max) | Pt10 | 1 | | | °C | on | 5 | 10 | 10 | 350 | 1 | * | 5 | 30 | 95 | 80 |
| Pt1000 (350°C max) | PT10 | 1 | | | °C | on | 10 | 10 | 10 | 350 | 1 | * | 5 | 0 | 350 | 80 |
| Pt100 (130°C max) | PT1 | 1 | | | °C | on | 5 | 10 | 10 | 350 | 1 | * | 5 | 0 | 95 | 80 |
| Pt100 (350°C max) | Pt1 | 1 | | | °C | on | 10 | 10 | 10 | 350 | 1 | * | 5 | 0 | 350 | 80 |
| Pt100 (0÷100°C 4÷20mA) | 4.20 | 1 | 0 | 100 | | on | 5 | 10 | 10 | 350 | 1 | * | 5 | 0 | 95 | 80 |
| Thermocouple K (1200°C max) | crAL | 0 | | | °C | on | 20 | 25 | 10 | 350 | 1 | * | 5 | 0 | 1200 | 80 |
| Thermocouple J (1000°C max) | J | 0 | | | °C | on | 20 | 25 | 10 | 350 | 1 | * | 5 | 0 | 1000 | 80 |
| 4-20mA / 0-1,6bar Pressure probe | 4.20 | 0 | 0 | 160 | | on | 20 | 20 | 5 | 120 | 1 | * | 5 | 0 | 160 | 100 |
| 4-20mA / 0-10bar Pressure probe | 4.20 | 0 | 0 | 1000 | | on | 50 | 50 | 5 | 120 | 1 | * | 5 | 0 | 1000 | 600 |
| 4-20mA / 0-16bar Pressure probe | 4.20 | 0 | 0 | 1600 | | on | 80 | 80 | 5 | 120 | 1 | * | 5 | 0 | 1600 | 600 |
| 4-20mA / 0-25bar Pressure probe | 4.20 | 0 | 0 | 2500 | | on | 125 | 125 | 5 | 120 | 1 | * | 5 | 0 | 2500 | 600 |
| 4-20mA / 0-40bar Pressure probe | 4.20 | 0 | 0 | 4000 | | on | 200 | 200 | 5 | 120 | 1 | * | 5 | 0 | 4000 | 600 |
| QBE2002 / 0-25bar Pressure probe | 0.10 | 0 | 0 | 2500 | | 0n | 125 | 125 | 5 | 120 | 1 | * | 5 | 0 | 2500 | 600 |

Note:

(*) Str.t - Servomotor stroke time

SQL33; STM30; SQM10; SQM40; SQM50; SQM54 = 30 (Seconds)

STA12B3.41; SQN30.251; SQN72.4A4A20 = 12 (Seconds)

() Out 4 ... on Display led °4 must be switched on, otherwise change the io4.F parameter value from "on" to "out4", confirm the value, quit the configuration mode then change again the io4.F parameter value from "out4" to "on".**







(***) Factory settings. These values must be adapted to machine conditions

N.B. For pressure probe, SP, SPHL, SPLL parameters values are expressed in Kpa (1 bar = 100 Kpa).

CONFIGURATION









How to access configuration level

The configuration parameters are collected in various groups. Every group defines all parameters related with a specific function (e.g.: control, alarms, output functions).

1. Push the  button for more than 5 seconds. The upper display will show PASS while the lower display will show 0.
2. Using  and  buttons set the programmed password.
According to the entered password, it is possible to see a part of the parameters listed in the "configuration parameters" section.
 - a. Enter "30" as password to view all the configuration parameters
 - b. Enter "20" as password to view the parameters of the "limited access level". At this point, only the parameters with attribute **Liv = A** or **Liv = O** will be editable.
 - c. Leave the password blank to edit "user level" parameters, that are identified by attribute **Liv = O**
3. Push the  button. If the password is correct the display will show the acronym of the first parameter group preceded by the symbol: . In other words the upper display will show:  inP (group of the **Input parameters**).

The instrument is in configuration mode. To press  for more than 5 seconds, the instrument will return to the "standard display".

Keyboard functions during parameter changing:

| Operator Mode | |
|---|--|
|  | When the upper display is showing a group and the lower display is blank, this key allows to enter in the selected group. When the upper display is showing a parameter and the lower display is showing its value, this key allows to store the selected value for the current parameter and access the next parameter within the same group. |
|  | Allows to increase the value of the selected parameter. |
|  | Allows to decrease the value of the selected parameter. |
|  | Short presses allow you to exit the current group of parameters and select a new group. A long press terminates the configuration procedure (the instrument returns to the normal display). |
|  +  | These two keys allow to return to the previous group. Proceed as follows: Push the  button and maintaining the pressure, then push the  ; release both the buttons. |

Configuration Parameters

| inP GROUP - input configuration | | | | | |
|---------------------------------|----|-------|---|---|----------------------|
| Liv | N° | Param | Description | Values | Default |
| A | 1 | SEnS | Input type | Pt1 = RTD Pt100 Pt10 = RTD Pt1000 0.20 = 0..20mA 4.20 = 4..20mA Pressure probe 0.10 = 0..10V 2.10 = 2..10V crAL= Thermocouple K | Depends on the probe |
| A | 2 | dp | Decimal point position | 0... 3 | See page 7 |
| A | 3 | SSc | Initial scale read-out for linear inputs (available only if SEnS parameter is not equal to Pt1, Pt10, crAL values) | -1999... 9999 | 0 |
| C | 4 | FSc | Full scale read-out for linear input inputs (available only if SEnS parameter is not equal to Pt1, Pt10, crAL values) | -1999... 9999 | Depends on the probe |
| C | 5 | unit | Unit of measure (present only in the case of temperature probe) | °C/°F | °C |
| C | 6 | Fil | Digital filter on the measured value | 0 (= OFF)... 20.0 s | 1.0 |
| C | 7 | inE | Selection of the Sensor Out of Range type that will enable the safety output value | or = Over range ou = Under range our = over e under range | or |

| | | | | | |
|---|----|-------|--|--|----|
| C | 8 | oPE | Safety output value | -100... 100 | 0 |
| C | 9 | io4.F | I/O4 function selection | on = Out4 will be ever ON (used as a transmitter power supply) ,out4 = Uscita 4 (Used as digital output 4), dG2c = Digital input 2 for contact closure, dG2U = Digital input 2 driven by 12... 24 VDC | on |
| C | 10 | diF1 | Digital input 1 function | oFF = Not used, 1 = Alarm reset, 2 = Alarm acknowledge (ACK), 3 = Hold of the measured value, 4 = Stand by mode, 5 = Manual mode, 6 = HEAt with SP1 and Cool with SP2, 7 = Timer RUN/Hold/Reset, 8 = Timer Run, 9 = Timer Reset, 10 = Timer Run/Hold, 11 = Timer Run/Reset, 12 = Timer Run/Reset with lock, 13 = Program Start, 14 = Program Reset, 15 = Program Hold, 16 = Program Run/Hold, 17 = Program Run/Reset, 18 = Sequential SP selection, 19 = SP1 - SP2 selection, 20 = SP1... SP4 binary selection, 21 = Digital inputs in parallel | 19 |
| C | 12 | di.A | Digital Inputs Action (DI2 only if configured) | 0 = DI1 direct action, DI2 direct action 1 = DI1 reverse action, DI2 direct action 2 = DI1 direct action, DI2 reverse action 3 = DI1 reverse action, DI2 reverse action | 0 |

Out GROUP- Output parameters

| Liv | N° | Param | Description | Values | Default |
|-----|----|-------|--|--|---------|
| C | 14 | o1F | Out 1 function | AL = Alarm output | AL |
| C | 15 | o1AL | Initial scale value of the analog retransmission | -1999 ... Ao1H | 1 |
| C | 18 | o1Ac | Out 1 action | dir = Direct action rEU = Reverse action dir.r = Direct with reversed LED ReU.r = Reverse with reversed LED | rEU.r |
| C | 19 | o2F | Out 2 function | H.rEG = Heating output | H.rEG |
| C | 21 | o2Ac | Out 2 action | dir = Direct action rEU = Reverse action dir.r = Direct with reversed LED ReU.r = Reverse with reversed LED | dir |
| C | 22 | o3F | Out 3 function | H.rEG = Heating output | H.rEG |
| C | 24 | o3Ac | Out 3 action | dir = Direct action rEU = Reverse action dir.r = Direct with reversed LED ReU.r = Reverse with reversed LED | dir |

AL1 GROUP - Alarm 1 parameters

| Liv | N° | Param | Descrizione | Values | Default |
|-----|----|-------|------------------|---|---------|
| C | 28 | AL1t | Tipo allarme AL1 | nonE = Alarm not used LoAb = Absolute low alarm HiAb = Absolute high alarm LHAo = Windows alarm in alarm outside the windows LHAI = Windows alarm in alarm inside the | HidE |

| | | | | | |
|---|----|------|---|--|------------|
| | | | | windows SE.br = Sensor Break LodE = Deviation low alarm (relative) HidE = Deviation high alarm (relative) LHdo = Relative band alarm in alarm out of the band LHdi = Relative band alarm in alarm inside the band | |
| C | 29 | Ab1 | Alarm 1 function | 0... 15 +1 = Not active at power up +2 = Latched alarm (manual reset) +4 = Acknowledgeable alarm +8 = Relative alarm not active at set point change | 0 |
| C | 30 | AL1L | -- For High and low alarms, it is the low limit of the AL1 threshold; -- For band alarm, it is low alarm threshold | -1999... AL1H (E.U.) | -199.9 |
| C | 31 | AL1H | -- For High and low alarms, it is the high limit of the AL1 threshold; -- For band alarm, it is high alarm threshold | AL1L... 9999 (E.U.) | 999.9 |
| O | 32 | AL1 | AL1 threshold | AL1L... AL1H (E.U.) | See page 7 |
| O | 33 | HAL1 | AL1 hysteresis | 1... 9999 (E.U.) | See page 7 |
| C | 34 | AL1d | AL1 delay | 0 (oFF)... 9999 (s) | oFF |
| C | 35 | AL1o | Alarm 1 enabling during Stand-by mode and out of range conditions | 0 = Alarm 1 disabled during Stand by and out of range 1 = Alarm 1 enabled in stand by mode 2 = Alarm 1 enabled in out of range condition 3 = Alarm 1 enabled in stand by mode and in overrange condition | 1 |

GRUPPO AL2 - parametri allarme 2

| Liv | N° | Param | Description | Values | Default |
|-----|----|-------|---|--|---------|
| C | 36 | AL2t | Alarm 2 type | nonE = Alarm not used LoAb = Absolute low alarm HiAb = Absolute high alarm LHAo = Windows alarm in alarm outside the windows LHAI = Windows alarm in alarm inside the windows SE.br = Sensor Break LodE = Deviation low alarm (relative) HidE = Deviation high alarm (relative) LHdo = Relative band alarm in alarm out of the band LHdi = Relative band alarm in alarm inside the band | SE.br |
| C | 37 | Ab2 | Alarm 2 function | 0... 15 +1 = Not active at power up +2 = Latched alarm (manual reset) +4 = Acknowledgeable alarm +8 = Relative alarm not active at set point change | 0 |
| C | 42 | AL2d | AL2 hysteresis | 0 (oFF)... 9999 (s) | oFF |
| C | 43 | AL2o | Alarm 2 enabling during Stand-by mode and out of range conditions | 0 = Alarm 2 disabled during Stand by and out of range 1 = Alarm 2 enabled in stand by mode 2 = Alarm 2 enabled in out of range condition 3 = Alarm 2 enabled in stand by mode and in overrange condition | 0 |

| AL3 Group - alarm 3 parameters | | | | | |
|--------------------------------|----|-------|--------------|--|---------|
| Liv | N° | Param | Description | Values | Default |
| | 44 | AL3t | Alarm 3 type | nonE = Alarm not used LoAb = Absolute low alarm HiAb = Absolute high alarm LHAo = Windows alarm in alarm outside the windows LHAI = Windows alarm in alarm inside the windows SE.br = Sensor Break LodE = Deviation low alarm (relative) HidE = Deviation high alarm (relative) LHdo = Relative band alarm in alarm out of the band LHdi = Relative band alarm in alarm inside the band | nonE |

| LbA Group - Loop break alarm | | | | | |
|------------------------------|----|-------|-------------|-----------------------|---------|
| Liv | N° | Param | Descrizione | Values | Default |
| C | 52 | LbAt | LBA time | Da 0 (oFF) a 9999 (s) | oFF |

| rEG Group - Control parameters | | | | | |
|--------------------------------|----|-------|--------------------------------|---|---------|
| Liv | N° | Param | Description | Values | Default |
| C | 56 | cont | Control type | Pid = PID (heat and/or) On.FA = ON/OFF asymmetric hysteresis On.FS = ON/OFF symmetric hysteresis nr = Heat/Cool ON/OFF control with neutral zone 3Pt = Servomotor control (available only when Output 2 and Output 3 have been ordered as "M") | 3pt |
| C | 57 | Auto | Autotuning selection | -4 = Oscillating auto-tune with automatic restart at power up and after all point change -3 = Oscillating auto-tune with manual start -2 = Oscillating -tune with auto-matic start at the first power up only -1 = Oscillating auto-tune with auto-matic restart at every power up 0 = Not used 1 = Fast auto tuning with automatic restart at every power up 2 = Fast auto-tune with automatic start the first power up only 3 = FAST auto-tune with manual start 4 = FAST auto-tune with automatic restart at power up and after set point change 5 = Evo-tune with automatic restart at every power up 6 = Evo-tune with automatic start the first power up only 7 = Evo-tune with manual start 8 = Evo-tune with automatic restart at power up and after a set point change | 7 |
| C | 58 | tunE | Manual start of the Autotuning | oFF = Not active on = Active | oFF |

| | | | | | |
|---|----|-------|----------------------------------|--|------------|
| C | 59 | SELF | Self tuning enabling | no = The instrument does not perform the self-tuning YES = The instrument is performing the self-tuning | No |
| A | 62 | Pb | Proportional band | 1... 9999 (E.U.) | See page 7 |
| A | 63 | ti | Integral time | 0 (oFF) ... 9999 (s) | See page 7 |
| A | 64 | td | Derivative time | 0 (oFF) ... 9999 (s) | See page 7 |
| C | 65 | Fuoc | Fuzzy overshoot control | 0.00... 2.00 | 1 |
| C | 69 | rS | Manual reset (Integral pre-load) | -100.0... +100.0 (%) | 0.0 |
| A | 70 | Str.t | Servomotor stroke time | 5...1000 seconds | See page 7 |
| A | 71 | db.S | Servomotor dead band | 0...100% | 5 |
| C | 72 | od | Delay at power up | 0.00 (oFF) ... 99.59 (hh.mm) | oFF |

SP Group - Set point parameters

| Liv | N° | Param | Description | Values | Default |
|-----|----|-------|--|--|------------|
| C | 76 | nSP | Number of used set points | 1... 4 | 2 |
| A | 77 | SPLL | Minimum set point value | -1999 ... SPHL | See page 7 |
| A | 78 | SPHL | Maximum set point value | SPLL ... 9999 | See page 7 |
| O | 79 | SP | Set point 1 | SPLL ... SPLH | See page 7 |
| C | 80 | SP 2 | Set point 2 | SPLL ... SPLH | 60 |
| | 83 | A.SP | Selection of the active set point | "SP" ... "nSP" | SP |
| C | 84 | SP.rt | Remote set point type | RSP = The value coming from serial link is used as remote set point trin = The value will be added to the local set point selected by A.SP and the sum becomes the operative set point PErc = The value will be scaled on the input range and this value will be used as remote SP | trin |
| C | 85 | SPLr | Local/remote set point selection | Loc = Local rEn = Remote | Loc |
| C | 86 | SP.u | Rate of rise for POSITIVE set point change (ramp UP) | 0.01... 99.99 (inF) Eng. units per minute | inF |
| C | 87 | SP.d | Rate of rise for NEGATIVE set point change (ramp DOWN) | 0.01... 99.99 (inF) Eng. units per minute | inF |

PAn Group - Operator HMI

| Liv | N° | Param | Description | Values | Default |
|-----|-----|-------|--|---|---------|
| C | 118 | PAS2 | Level 2 password (limited access level) | oFF (Level 2 not protected by password) 1... 200 | 20 |
| C | 119 | PAS3 | Level 3 password (complete configuration level) | 3... 300 | 30 |
| C | 120 | PAS4 | Password livello (livello configurazione a codice) | 201... 400 | 300 |
| C | 121 | uSrb | button function during RUN TIME | nonE = No function tunE = Auto-tune/self-tune enabling. A single press (longer than 1 second) starts the auto-tune oPLo = Manual mode. The first pressure puts the instrument in manual mode (OPLO) while a second one puts the instrument in Auto mode | tunE |

| | | | | | |
|---|-----|-------|-------------------------------|---|------|
| | | | | AAC = Alarm reset ASi = Alarm acknowledge chSP = Sequential set point selection St.by = Stand by mode. The first press puts the instrument in stand by mode while a second one puts the instrument in Auto mode. Str.t = Timer run/hold/reset P.run = Program run P.rES = Program reset P.r.H.r = Program run/hold/reset | |
| C | 122 | diSP | Display management | Spo = Operative set point | SPO |
| C | 123 | di.cL | Display colour | 0 = The display colour is used to show the actual deviation (PV - SP) 1 = Display red (fix) 2 = Display green (fix) 3 = Display orange (fix) | 2 |
| | 125 | diS.t | Display Timeout | -- oFF (display always ON) -- 0.1... 99.59 (mm.ss) | oFF |
| C | 126 | fiLd | Filter on the displayed value | -- oFF (filter disabled) -- From 0.0 (oFF) to 20.0 (E.U.) | oFF |
| C | 128 | dSPu | Instrument status at power ON | AS.Pr = Starts in the same way it was prior to the power down Auto = Starts in Auto mode oP.0 = Starts in manual mode with a power output equal to zero St.bY = Starts in stand-by mode | Auto |
| C | 129 | oPr.E | Operative modes enabling | ALL = All modes will be selectable by the next parameter Au.oP = Auto and manual (OPLO) mode only will be selectable by the next parameter Au.Sb = Auto and Stand-by modes only will be selectable by the next parameter | ALL |
| C | 130 | oPEr | Operative mode selection | If oPr.E = ALL: - Auto = Auto mode - oPLo = Manual mode - St.bY = Stand by mode If oPr.E = Au.oP: - Auto = Auto mode - oPLo = Manual mode If oPr.E = Au.Sb: - Auto = Auto mode - St.bY = Stand by mode | Auto |

SEr Group - Serial link parameter

| Liv | N° | Param | Description | Values | Default |
|-----|-----|-------|---|--|---------|
| C | 131 | Add | Instrument address | -- oFF -- 1... 254 | 1 |
| C | 132 | bAud | baud rate | 1200 = 1200 baud 2400 = 2400 baud 9600 = 9600 baud 19.2 = 19200 baud 38.4 = 38400 baud | 9600 |
| C | 133 | trSP | Selection of the value to be retransmitted (Master) | nonE = Retransmission not used (the instrument is a slave) rSP = The instrument becomes a Master and retransmits the operative set point PErc = The instrument become a Master and it retransmits the power output | nonE |

| con Group - Consumption parameters | | | | | |
|------------------------------------|-----|-------|------------------------------|---|---------|
| Liv | N° | Param | Description | Values | Default |
| C | 134 | Co.tY | Count type | <p>oFF = Not used</p> <p>1 = Instantaneous power (kW)</p> <p>2 = Power consumption (kW/h)</p> <p>3 = Energy used during program execution. This measure starts from zero when a program runs end stops at the end of the program. A new program execution will reset the value</p> <p>4 = Total worked days: number of hours the instrument is turned ON divided by 24.</p> <p>5 = Total worked hours: number of hours the instrument is turned ON.</p> <p>6 = Total worked days with threshold: number of hours the instrument is turned ON divided by 24, the controller is forced in stand-by when Co.ty value reaches the threshold set in [137] h.Job.</p> <p>7 = Total worked hours with threshold: number of hours the instrument is turned ON, the controller is forced in stand-by when Co.ty value reaches the threshold set in [137] h.Job.</p> <p>8 = Totalizer of control relay worked days: number of hours the control relay has been in ON condition, divided by 24.</p> <p>9 = Totalizer of control relay worked hours: number of hours the control relay has been in ON condition.</p> <p>10 = Totalizer of control relay worked days with threshold: number of hours the control relay has been in ON condition divided by 24, the controller is forced in stand-by when Co.ty value reaches the threshold set in [137] h.Job.</p> <p>11 = Totalizer of control relay worked hours with threshold: number of hours the control relay has been in ON condition, the controller is forced in stand-by when Co.ty value reaches the threshold set in [137] h.Job.</p> | oFF |
| C | 138 | t.Job | Worked time (not resettable) | 0... 9999 days | 0 |

| cAL Group - User calibration group | | | | | |
|------------------------------------|-----|-------|--------------------|--|---------|
| Liv | N° | Param | Description | Values | Default |
| C | 139 | AL.P | Adjust Low Point | From -1999 to (AH.P - 10) in engineering units | 0 |
| C | 140 | AL.o | Adjust Low Offset | -300... +300 (E.U.) | 0 |
| C | 141 | AH.P | Adjust High Point | From (AL.P + 10) to 9999 engineering units | 999.9 |
| C | 142 | AH.o | Adjust High Offset | -300... +300 | 0 |

OPERATIVE MODES

When the instrument is powered, it starts immediately to work according to the parameters values loaded in its memory. The instrument behaviour and its performance are governed by the value of the stored parameters.

At power ON the instrument can start in one of the following mode depending on its configuration:

Automatic Mode In Automatic mode the instrument drives automatically the control output according to the parameter value set and the set point/measured value.

Manual Mode (OPLO): In Manual mode the the upper display shows the measured value while the lower display shows the power output The lower display shows the power output [preceded by H (for heating) or C (for cooling)], MAN is lit and the instrument allows you to set manually the control output power. No Automatic action will be made.





Stand by Mode (St.bY): In stand-by mode the instrument operates as an indicator. It will show on the upper display the measured value and on the lower display the set point alternately to the "St.bY" messages and forces the control outputs to zero.

We define all the above described conditions as "Standard Display".

As we have seen, it is always possible to modify the value assigned to a parameter independently from the operative modes selected.









AUTOMATIC MODE

Keyboard function when the instrument is in Auto mode:

| Modo Operatore | |
|---|---|
|  | Allows entry into parameter modification procedures |
|  | Allows you to start the "Direct set point modification" function (see below). |
|  | Allows you to display the "additional informations" (see below). |
|  | Performs the action programmed by [121] uSrb ( button function during RUN TIME) parameter |

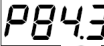
Additional information





This instrument is able to show you some additional informations that can help you to manage your system. The additional informations are related to how the instrument is programmed, hence in many cases, only part of this information is available.

1. When the instrument is showing the "standard display" push  button. The lower display will show H or c followed by a number. This value is the current power output applied to the process. The H show you that the action is a Heating action while the "c" show you that the action is a Cooling action
2. Push  button again. When the programmer is running the lower display will show the segment currently performed and the Event status as shown below:
 where the first character can be r for a ramp or S for a soak, the next digit show the number of the segment (e.g. S3 means Soak number 3) and the twoless significant digits (LSD) show you the status of the two event (the LSD is the Event 2)..
3. Push  button again. When the programmer is running the lower display will show the theoretical remaining time to the end of the program preceded by a "P" letter:

4. Push  button again. When the wattmeter function is running the lower display will show U followed by the measured energy..
5. Push  button. When the "Worked time count" is running the lower display will show "d" for days or "h" for hours followed by the measured time.
6. Push  button. The instrument returns to the "standard display".



Note: The additional information visualization is subject to a time out. If no button is pressed for more than 10 second the instrument comes automatically back to the Standard display..

Direct set point modification

This function allows to modify rapidly the set point value selected by [83] A.SP (selection of the active Set point) or to the set point of the segment group (of the programmer) currently in progress.

1. Push  button. The upper display shows the acronym of the selected set point (e.g. SP2) and the lower display will show its value.
2. By  and  buttons, assign to this parameter the desired value
3. Do not push any button for more than 5 second or push the  button. In both cases the instrument memorize the new value and come back to the “standard display”.

Manual mode

This operative mode allows you to deactivate automatic control and manually program the percentage power output to the process. When the instrument is in manual mode, the upper display shows the measured value while the lower display shows the power output [preceded by H (for heating action) or C (for cooling action)] The MAN LED is lit. When manual control is selected, the instrument will start to operate with the same power output as the last one supplied by automatic mode and can be modified using the  and  buttons.

In case of ON/OFF control, 0% corresponds to the deactivated output while any value different from 0 corresponds to the activated output. As in the case of visualization, the programmable values range from H100 (100% output power with reverse action) to C100 (100% output power with direct action).

Notes:

- During manual mode, the alarms are operative.
- If you set manual modes during program execution, the program will be frozen and it will restart when the instrument will come back to Auto mode.
- If you set manual modes during self-tune execution, the self- tune function will be aborted.
- During manual mode, all functions not related with the control (wattmeter, independent timer, “worked time”, etc) continue to operate normally..

STAND-BY MODE

This operative mode also deactivates the automatic control but forces the control output to zero. In this mode the instrument operates as an indicator. When the instrument is in stand by mode the upper display will show the measured value while the lower display will show alternately the set point and the message “St.bY”.

Notes:

- During stand by mode, the relative alarms are disabled while the absolute alarms are operative or not according to the ALx0 (Alarm x enabling during Stand-by mode) parameter setting.
- If you set stand by mode during program execution, the program will be aborted.
- If you set stand by mode during self-tune execution, the self- tune function will be aborted.
- During stand by mode, all functions not related with the control (wattmeter, independent timer, “worked time”, etc) continue to operate normally.
- When the instrument is swapped from stand by to auto modes, the instrument will start automatically the alarm masking, the soft start functions and the auto-tune (if programmed).

AUTOTUNE (EVOTUNE)

Evotune is a fast and fully automatic procedure that can be started in any condition, regardless the deviation from SP. The controller selects automatically the best tune method and computes the optimum PID parameters. To activate Evotune press  button for 3 seconds.

ERROR MESSAGES

The upper display shows the OVER-RANGE and UNDERRANGE conditions with the following indications:

Over-range: 

Under-range 

The sensor break will be signalled as an out of range: - - - -

Note: When an over-range or an under-range is detected, the alarms operate as in presence of the maximum or the minimum measurable value respectively.

To check the out of span Error condition, proceed as follows:

1. Check the input signal source and the connecting line.
2. Make sure that the input signal is in accordance with the instrument configuration. Otherwise, modify the input configuration.
3. If no error is detected, send the instrument to your supplier to be checked.

List of possible errors

ErAT Fast Auto-tune cannot start. The measure value is too close to the set point. Push the button in order to delete the error message.

ouLd Overload on the out 4. The messages shows that a short circuit is present on the Out 4 when it is used as output or as a transmitter power supply. When the short circuit disappears the output restart to operate..

NoAt Auto-tune not finished within 12 hours.

ErEP Possible problem of the instrument memory. The messages disappears automatically. When the error continues, send the instrument to your supplier.





RonE Possible problem of the firmware memory. When this error is detected, send the instrument to your supplier.

Errt Possible problem of the calibration memory. When this error is detected, send the instrument to your supplier.

FACTORY RESET

Sometime, e.g. when you re-configure an instrument previously used for other works or from other people or when you have made too many errors during configuration and you decided to re-configure the instrument, it is possible to restore the factory configuration. This action allows to put the instrument in a defined condition (the same it was at the first power ON).

The default data are those typical values loaded in the instrument prior to ship it from factory. To load the factory default parameter set, proceed as follows:

1. Press the  button for more than 5 seconds. The upper display will show PASS while the lower display shows 0;
2. Using  and  buttons set the value -481;
3. Push  button;
4. The instrument will turn OFF all LEDs for a few seconds, then the upper display will show dFLt (default) and then all LEDs are turned ON for 2 seconds. At this point the instrument restarts as for a new power ON.

The procedure is complete.

Note: The complete list of the default parameters is available in Chapter "Configuration".

RWF55.5X & RWF55.6X



User manual

DEVICE INSTALLATION

Fixing system

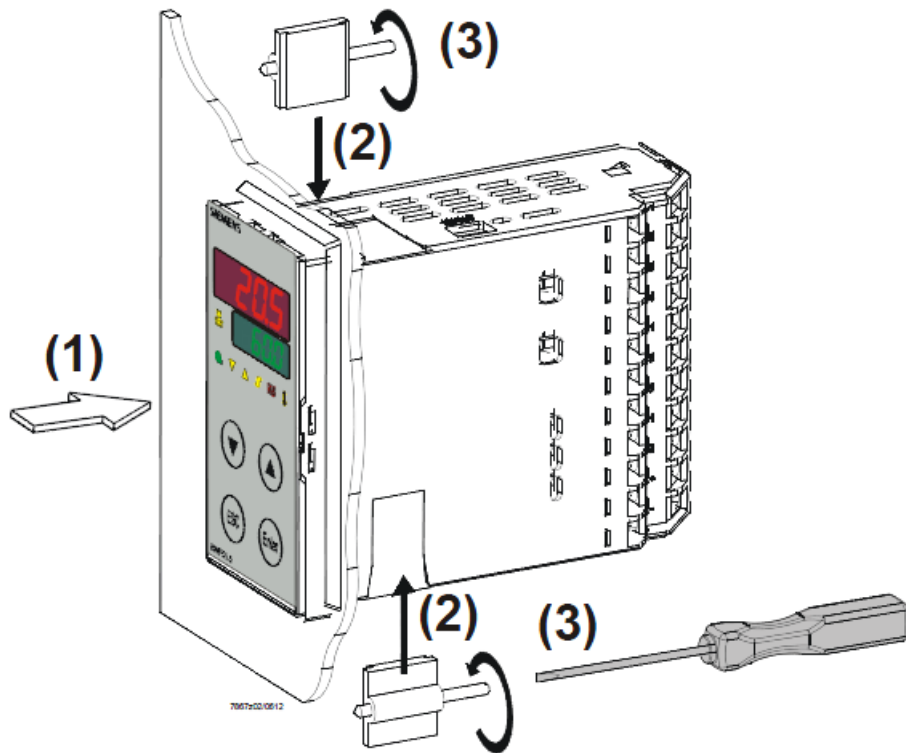

Drilling dimensions:

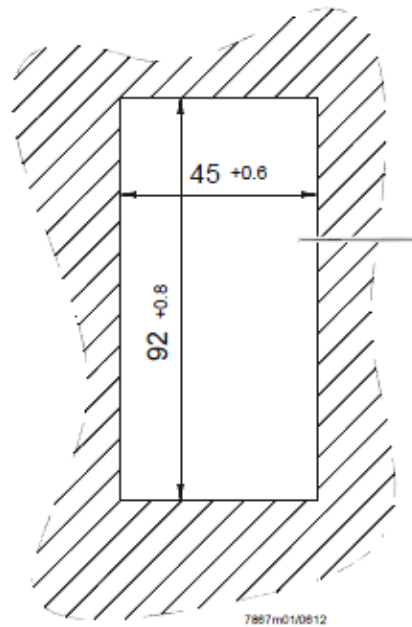

FRONT PANEL

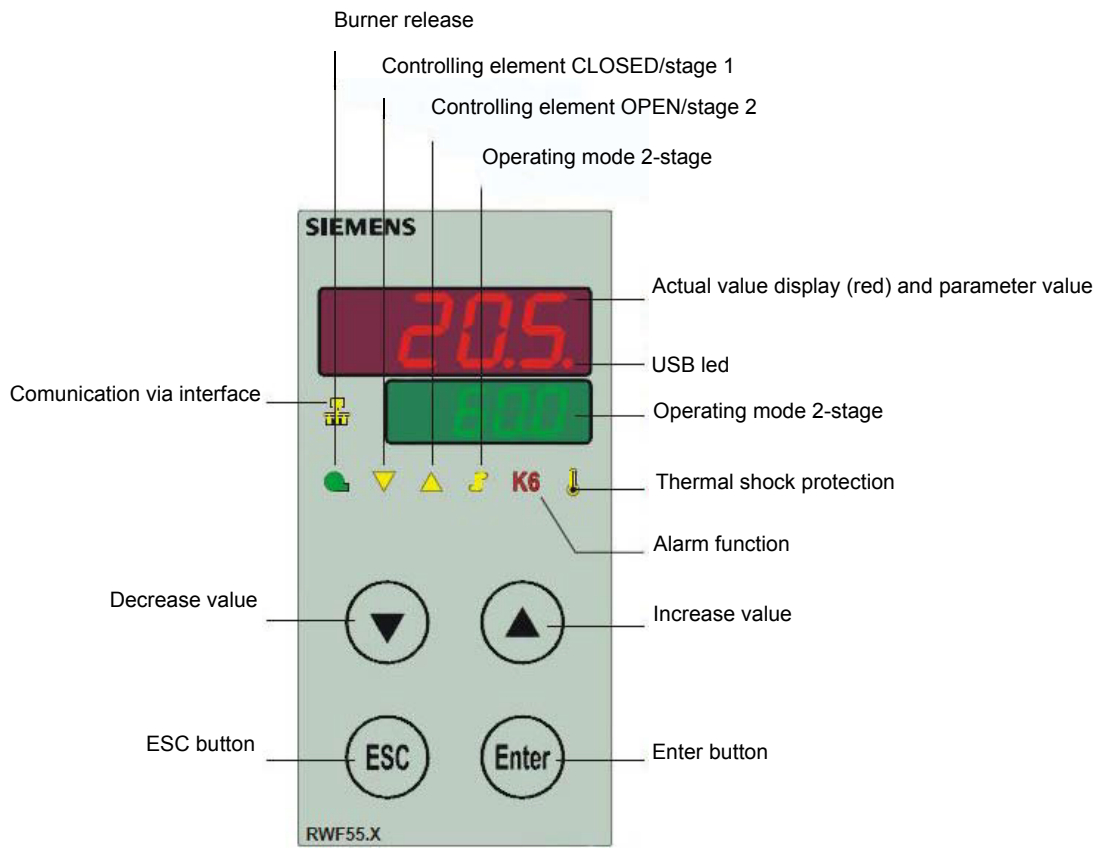

NAVIGATION MENU

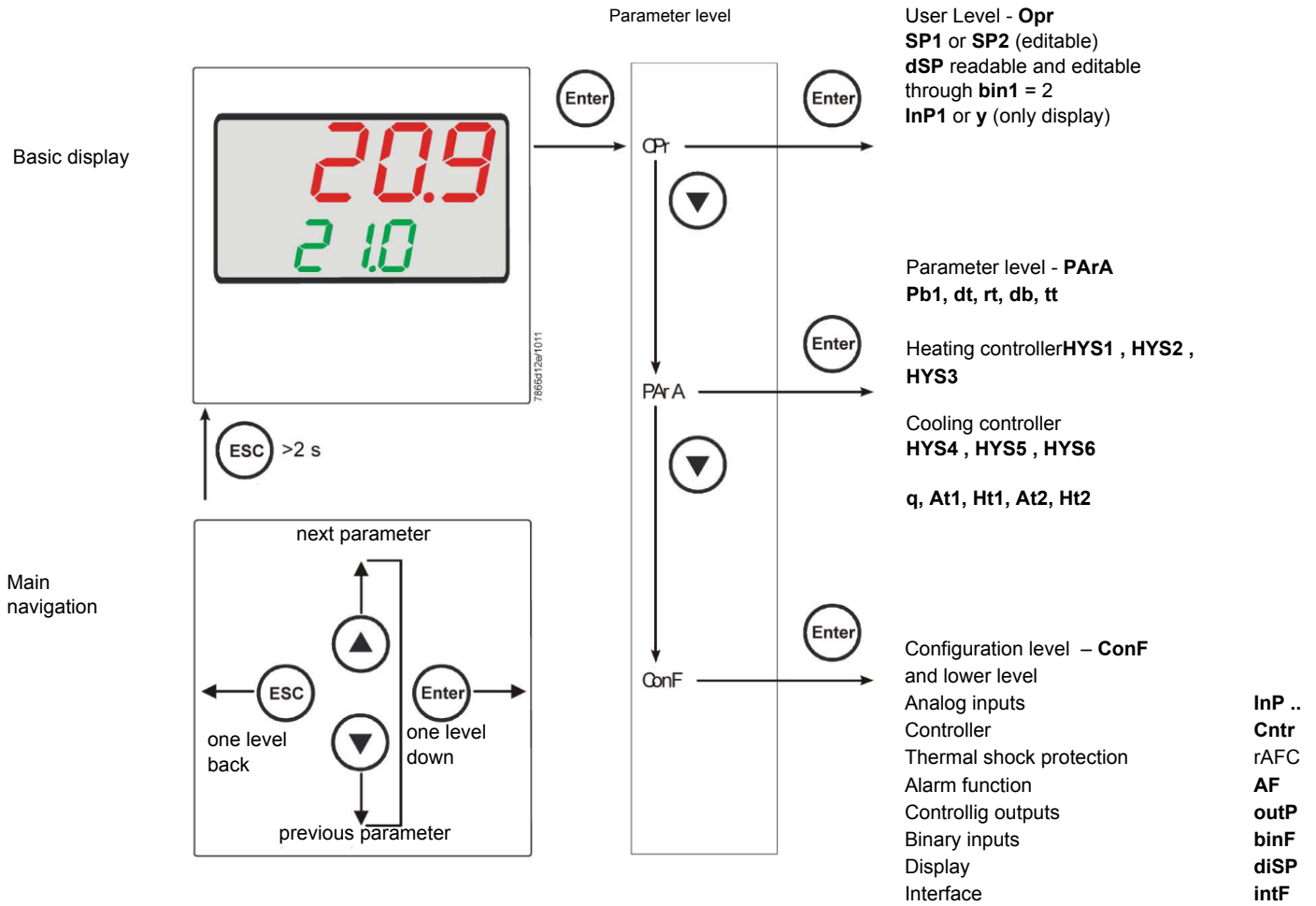

RWF55 is preset good for 90% of applications. However, you can set or edit parameters as follow:

Set-point: set or modification:

When the burner is in stand-by, (safety loop open, that is terminals 3-4/T1-T2 on the 7 pole plug open) push the Enter button: on the lower display (green) Opr appears; push Enter again and in the same display SP1 appears. Push Enter again and the lower display (green SP1) flashes. Using the up and down arrows change the set-point on the upper display (red).Push Enter to confirm and push ESC more times to get the home position.

PID parameters set and modifications (PARA):

Push **Enter** button, on the green display **Opr** appears; using the **down arrow**, scroll until group **PARA** is reached and push **Enter**.
On the green display **Pb1** e appears and on the red one the set parameter. Push in sequence the **down or up** arrow the menu is scrolled.
Push **Enter** to select and the **arrows** to choose the desired value. **Enter** to confirm

| Parameter | Display | Range | Factory setting | Remarks |
|--|---------|--------------------|-----------------|--|
| Proportional band | Pb1 | 1... 9999 digit | 10 | Typical value for temperature |
| Derivative action | dt | 0... 9999 sec. | 80 | Typical value for temperature |
| Integral action | rt | 0... 9999 sec. | 350 | Typical value for temperature T |
| Dead band (*) | db | 0... 999,9 digit | 1 | Typical value |
| Servocontrol running time | tt | 10... 3000 sec. | 15 | Set servocontrol running time |
| Switch-on differential (*) | HYS1 | 0,0... -1999 digit | -5 | Value under setpoint below which the burner switches back on (1N-1P closes) |
| Switch-off differential 2° stage (*) | HYS2 | 0,0 ... HYS3 | 3 | (enable only with parameter bin1 = 4) |
| Upper switch-off differential (*) | HYS3 | 0,0... 9999 digit | 5 | Value over setpoint above which the burner switches off (1N-1P opens) |
| Switch-on differential on cooling controller (*) | HYS4 | 0,0... 9999 digit | 5 | Do not used (enable only with parameter CACT = 0) |
| Switch-off differential 2° stage on cooling controller (*) | HYS5 | HYS6...0,0 digit | 5 | Do not used (enable only with parameter CACT = 0 and parameter bin1 =0) |
| Upper switch-off differential on cooling controller (*) | HYS6 | 0,0... -1999 digit | 5 | Do not used (enable only with parameter CACT = 0) |
| Delay modulation | q | 0,0... 999,9 digit | 0 | Do not alter |
| T Outside temperature Curve point 1 (*) | At1 | -40 ...120 digit | -10 | First point of external temperature for climatic curve |
| Boiler temperature Curve point 1 (*) | Ht1 | SPL...SPH | 60 | Set-point temperature for the external temperature 1 |
| TT Outside temperature Curve point 2 (*) | At2 | -40 ...120 digit | 20 | Second point of external temperature for climatic curve |
| Boiler temperature Curve point 2 (*) | Ht2 | SPL...SPH | 50 | Set-point temperature for the external temperature 2 |

(*) Parameters affected by setting of decimal place (**ConF** > **dISP** parameter **dECP**)

Setting the kind of sensor to be connected to the device:

Push the **Enter** button: on the lower display (green) **Opr** appears. Using the **up and down arrows** find **ConF**. Push **Enter** to confirm. Now on the green display the group **InP** appears. Push **Enter** and **InP1** is displayed. Enter to confirm. You are inside **InP1**; the green display shows **Sen1 (sensor type)**, while the red display shows the chosen sensor code Push **Enter** to enter the **Sen1** parameter, then choose the desired sensor using the **arrows**. Push **Enter** to confirm and **ESC** to escape.

Once selected the sensor, you can modify all the other parameters using **up and down arrows** according to the tables here below :

ConF > InP > InP1

| Parameter | Value | Description |
|--|-----------------------------|---|
| SEn1 type of sensor for analog input 1 | 1 | Pt100 3 wire |
| | 2 | Pt100 2 wire |
| | 3 | Pt1000 3 wire |
| | 4 | Pt1000 2 wire |
| | 5 | Ni1000 3 wire |
| | 6 | Ni1000 2 wire |
| | 7 | 0 ÷ 135 ohm |
| | 8 | Cu-CuNi T |
| | 9 | Fe-CuNi J |
| | 10 | NiCr-Ni K |
| | 11 | NiCrSi-NiSi N |
| | 12 | Pt10Rh-Pt S |
| | 13 | Pt13Rh-Pt R |
| | 14 | Pt30Rh-Pt6Rh B |
| | 15 | 0 ÷ 20mA |
| | 16 | 4 ÷ 20mA |
| | 17 | 0 ÷ 10V |
| | 18 | 0 ÷ 5V |
| | 19 | 1 ÷ 5V |
| OFF1 Sensor offset | -1999..0.. +9999 | Correction value measured by the sensor |
| SCL1 scale low level | -1999..0.. +9999 | minimum scale value(for input ohm, mA, V) |
| SCH1 scale high level | -1999.. 100 .. +9999 | maximum scale value(for input ohm, mA, V) |
| dF1 digital filter | 0... 0,6 ...100 | Is used to adapt the digital 2nd order input filter (time in s; 0 s = filter off) |
| Unit temperature unit | 1 | 1 = degrees Celsius |
| | 2 | 2 = degrees Fahrenheit |

(**bold** = factory settings)

ConF > InP > InP2

Input 2 : this input can be used to specify an external setpoint or carry out setpoint shifting

| Parameter | Value | Description |
|-----------------------------|-----------------------------|---|
| FnC2 | 0 | 0= no function |
| | 1 | 1= external setpoint (display SPE) |
| | 2 | 2 =setpoint shifting (display dSP) |
| | 3 | 3 = angular positioning feedback |
| SEn2 sensor type input 2 | 1 | 0 ÷ 20mA |
| | 2 | 4 ÷ 20mA |
| | 3 | 0 ÷ 10V |
| | 4 | 0 ÷ 5V |
| | 5 | 1 ÷ 5V |
| | 1 | 0 ÷ 20mA |
| OFF2 Sensor offset | -1999..0.. +9999 | Correction value measured by the sensor |
| SCL2 scale low level | -1999..0.. +9999 | minimum scale value(for input ohm, mA, V) |
| SCH2 scale high level | -1999.. 100 .. +9999 | maximum scale value(for input ohm, mA, V) |
| dF2 digital filter | 0... 2 ...100 | Is used to adapt the digital 2nd order input filter (time in s; 0 s = filter off) |

(**bold** = factory settings)

ConF > InP > InP3

Input 3: this input is used to acquire the outside temperature

| Parameter | Value | Description |
|--|--------------------------|---|
| SEn3 sensor type input 3 sensor type input 2 | 0 | 0 = |
| | 1 | 1 = wire |
| | 2 | 2 = wire |
| OFF3 Sensor offset | -1999..0.. +9999 | Correction value measured by the sensor |
| dF3 digital filter | 0... 1278 ...1500 | Is used to adapt the digital 2nd order input filter (time in s; 0 s = filter off) |

(**bold** = factory settings)

ConF > Cntr

Here, the type of controller, operating action, setpoint limits and presettings for self-optimization are selected

| Parameter | Value | Description |
|---|------------------|---|
| CtYP controller type | 1 2 | 1 = 3-position controller (open-stop-close) 2 = continuative action controller (0 ÷ 10V or 4 ÷ 20mA) |
| CACT control action | 1 0 | 1 = heating controller 0 = cooling controller |
| SPL least value of the set-point range | -1999..0..+9999 | minimum set-point scale |
| SPH maximum value of the set-point range | -1999..100..+999 | maximum set-point scale |
| Self-optimization | 0 1 | 0 = Free 1 = Locked Self-optimization can only be disabled or enabled via the ACS411 setup program. Self-optimization is also disabled when the parameter level is locked |
| oLLo set-point limitation start, operation limit low | -1999.... +9999 | lower working range limit |
| oLHi set-point limitation end, operation limit high | -1999.... +9999 | upper working range limit |

(bold = factory settings)

ConF > rAFC

Activation boiler shock termic protetion:

RWF55.. can activate the thermal shock protection only on sites where the set-point is lower than 250°C and according to **rAL** parameter

| Parameter | Value | Description |
|-----------------------------|------------------------|--|
| FnCT type of contol | 0 1 2 | choose type of range degrees/time 0 = deactivated 1 = Kelvin degrees/minute 2 = Kelvin degrees/hour |
| rASL ramp rate | 0,0 ... 999,9 | Slope of thermal shock protection (only with functions 1 and 2) |
| toLP tolerance band ramp | 2 x (HYS1) = 10...9999 | width of tolerance band (in K) about the set-point 0 = tolerance band inactive |
| rAL ramp limit | 0...250 | Ramp limit. When this value is lower than the temperature set-point, the RWF controls the output increasing the temp set point step by step according to rASL . If this is over the temp set point, the control is performed in cooling |

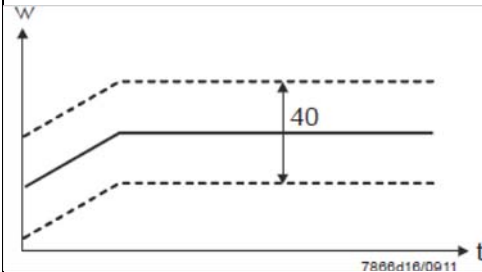

(bold = factory settings)

Alarm function AF

The alarm function can be used to monitor the analog inputs. If the limit value is exceeded, multifunctional relay K6 (terminals **6N** and **6P**) is activated (depending on the switching characteristic)

The alarm function can have different switching functions (Ik1 to Ik8) and can be set to a deviation from the active setpoint or to a fixed limit value

Limit value **AL** relative to setpoint (x)

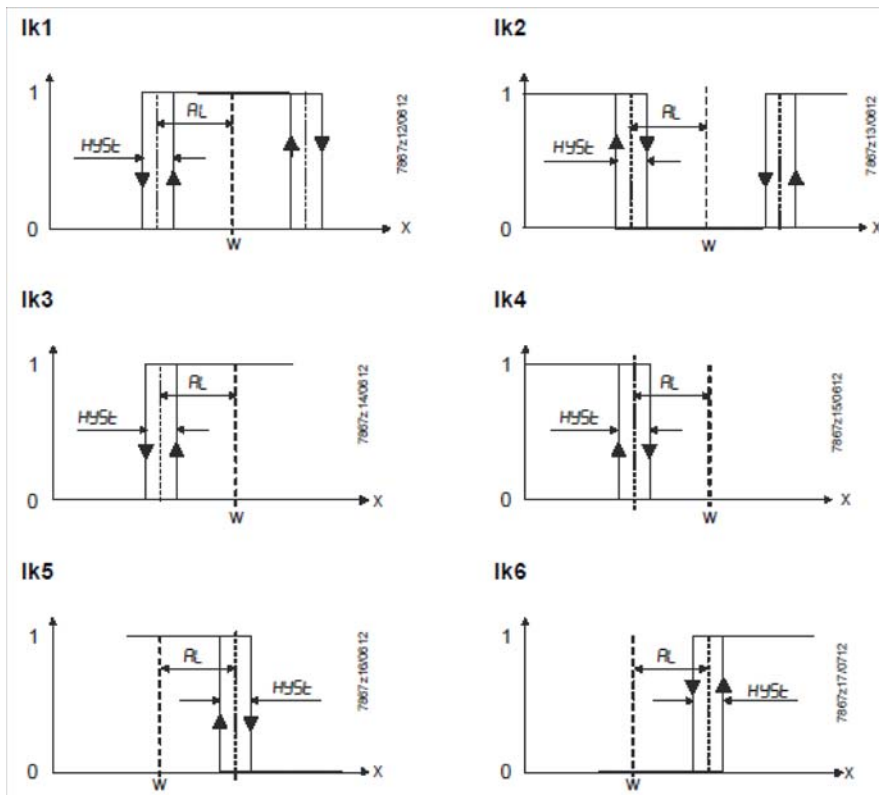

Fixed limit value **AL**

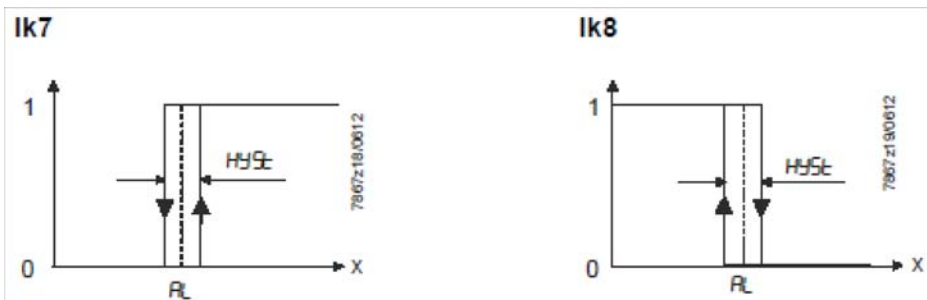

ConF > AF

| Parameter | Value | Description |
|----------------------------------|--|---|
| FnCt type of control | 0 1 2 3 4 5 6 7 8 9 10 11 12 | 0 = Without function lk1 = monitored input InP1 lk2 = monitored input InP1 lk3 = monitored input InP1 lk4 = monitored input InP1 lk5 = monitored input InP1 lk6 = monitored input InP1 lk7 = monitored input InP1 lk8 = monitored input InP1 lk7 = monitored input InP2 lk8 = monitored input InP2 lk7 = monitored input InP3 lk8 = monitored input InP3 |
| Alarm value AL | -1999 ... 0 1999 | Limit value or deviation from setpoint to be monitored (see alarm functions lk1 to lk8 : limit value AL) Limit value range for lk1 and lk20 ...9999 |
| HySt switching differential | 0... 1... 9999 | Switching differential for limit value AL |
| ACrA response by out of range | 0 1 | Switched-off ON Switching state in the case of measuring range overshoot or undershoot (Out of Range) |

(**bold** = factory settings)

ConF > OutP

For fuel-air ratio control purposes, the RWF55 has the binary outputs K2, K3 (terminals KQ, K2, K3) and the analog output (terminals A+, A-). The burner is released via relay K1 (terminals 1N, 1P).

The binary outputs of the RWF55 offer no setting choices

The RWF55 has an analog output.

The analog output offers the following setting choices:

| Parameter | Value | Description |
|---------------------------------------|------------------------------|---|
| FnCt type of control | 1 2 3 4 | 1 = analog input 1 doubling with possibility to convert 2 = analog input 2 doubling with possibility to convert 3 = analog input 3 doubling with possibility to convert 4 = Controller's angular positioning is delivered (modulating controller) |
| SiGn type of output signal | 0 1 2 | physical output signal (terminals A+, A-) 0 = 0÷20mA 1 = 4÷20mA 2 = 0÷10V DC |
| rOut value when out of input range | 0 ...101 | signal (in percent) when measurement range is crossed |
| oPnt zero point | -1999... 0 ...+9999 | A value range of the output variable is assigned to a physical output signal (for FnCt = 1, 2, 3) |
| End end point | -1999... 100 ...+9999 | A value range of the output variable is assigned to a physical output signal (for FnCt = 1, 2, 3) |

(**bold** = factory settings)

ConF > binF

This setting decides on the use of the binary inputs **D1**, **D2**, **DG**

b

| Parameter | Value | Description |
|---|-------------------------|--|
| bin1 binary input 1 (terminals DG – D1) | 0 1 2 3 | 0 = without function 1 = set-point changeover (SP1 / SP2) 2 = Iset-point shift (Opr > dSP parameter = value of set-point modify) 3 = input alarm |
| bin2 binary input 2 (terminals DG – D2) | 4 | changeover of operating mode DG-D2 open = modulating operation DG-D2 close = 2 stage operation |

(**bold** = factory settings)

ConF > dISP

.Both displays can be customized to suit your needs by configuring the displayed value, decimal, time out and blocking

| Parameter | Value | Description |
|-------------------------------|---|--|
| diSU upper display (red) | 0 1 2 3 4 6 7 | Display value for upper display: 0 = display power-off 1 = analog input 1 (InP1) value 2 = analog input 2 (InP2) value 3 = analog input 3 (InP3) value 4 = controller's angular positioning 6 = set-point values 7 = end value with thermal shock protection |
| diSL lower display (green) | 0 1 2 3 4 6 7 | Display value for lower display: 0 = display power-off 1 = analog input 2 (InP2) value 2 = analog input 2 (InP2) value 3 = analog input 2 (InP2) value 4 = controller's angular positioning 6 = set-point values 7 = end value with thermal shock protection |
| tout timeout | 0.. 180 ..250 | time (s) on completion of which the controller returns automatically to the basic display, if no button is pressed |
| dECP decimal point | 0 1 2 | 0 = no decimal place 1 = one decimal place 2 = two decimal place |
| CodE level lockout | 0 1 2 3 | 0 = no lockout 1 = configuration level lockout (ConF) 2 = parameter and configuration level lockout (PARa & ConF) 3 = keyboard lockout |

(**bold** = factory settings)

ConF > IntF

The controller can be integrated into a data network using an optional RS-485 (terminals R+ and R-) interface or an optional Profibus DP interface(only model **RWF55.6x** terminals C1-C2-C3-C4)

| Parameter | Value | Description |
|-------------------------|----------------|-----------------------------|
| bdrt | 0 | 0 = 4800 baud |
| baudrate | 1 | 1 = 9600 baud |
| | 2 | 2 = 19200 baud |
| | 3 | 3 = 38400 baud |
| | | |
| Adr | 0.. | Address in the data network |
| Device address Modbus | 1.. | |
| | 254 | |
| dP | 0.. 125 | only with RWF55.6x |
| Device address Profibus | | |
| dt | 0.. | 0 = switched-off |
| Remote detection time | 30 .. | |
| | 7200s | |

(**bold** = factory settings)

Manual control :

In order to manual change the burner load, while firing keep pushing the **ESC** button for more than 5 s; on the lower green display **Hand** appears.

using the **UP** and **DOWN** arrows, the load varies.

Keep pushing the **ESC** button for getting the normal operation again.

NB: every time the device shuts the burner down (start led switched off - contact 1N-1P open), the manual control is not active.

Device self-setting (auto-tuning):

If the burner in the steady state does not respond properly to heat generator requests, you can activate the Device's self-setting function, which recalculates PID values for its operation, deciding which are most suitable for the specific kind of request



Follow the below instructions:

push the **UP** and **DOWN** arrows for more than 5 s; on the green lower display **tUnE** appears. Now the device pushes the burner to increase and decrease its output. During this time, the device calculates **PID** parameters (**Pb1**, **dt** and **rt**). After the calculations, the **tUnE** is automatically deactivated and the device has already stored them.

In order to stop the Auto-tuning function while it works, push again the **UP** and **DOWN** arrows for more than 5 s. The calculated **PID** parameters can be manually modified following the previously described instructions.

Display of software version :

The software version is shown by pushing Enter + UP arrow on the upper display.



Weather-compensated setpoint shifting (climatic regulation):

The RWF55 can be configured so that weather-compensated setpoint shifting is activated when an LG-Ni1000 outside sensor or a Pt1000 is connected (see parameter **InP3**).

To take into account the time response of a building, weather-compensated setpoint shifting uses the attenuated outside temperature rather than the current outside temperature.

The minimum and maximum setpoints can be set using the lower setpoint limit **SPL** and the upper setpoint limit **SPH** of the menu **Crtr**.

The system also prevents the lower working range limit **oLLo** and upper working range limit **oLHi** from exceeding/dropping below the system temperature limits.

The heating curve describes the relationship between the boiler temperature setpoint and the outside temperature. It is defined by 2 curve points. For 2 outside temperatures, the user defines the boiler temperature setpoint that is required in each case. The heating curve for the weather-compensated setpoint is calculated on this basis. The effective boiler temperature setpoint is limited by the upper setpoint limit **SPH** and the lower setpoint limit **SPL**.

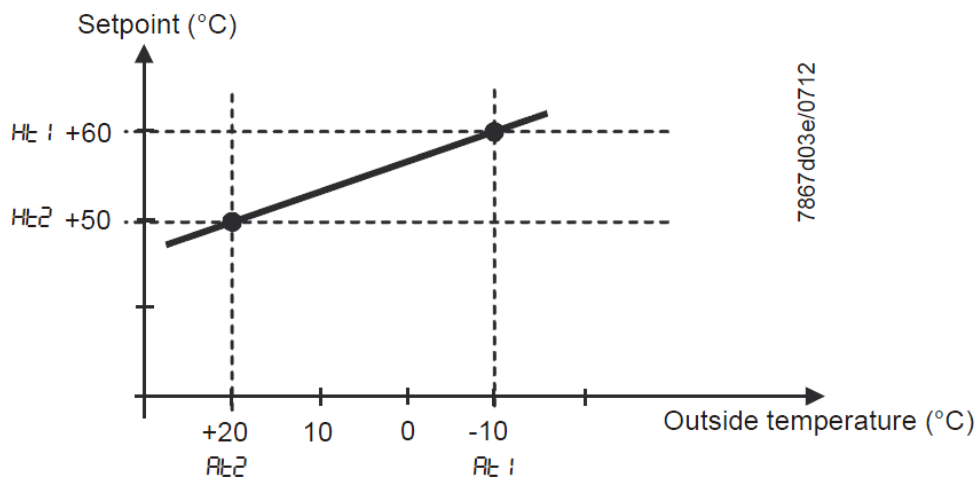

For setting climatic regulation function set:

PArA > parameters **At1**, **Ht1**, **At2**, **Ht2**

ConF > **InP** > **InP3** parameters **SEn3**, **FnC3** = 1 (Weather-compensated setpoint).

Modbus interface

The tables that follow in this chapter specify the addresses of the readable and writable words that the customer is able to access. The customer may read and/or write the values using SCADA programs, PLCs, or similar.

The entries under Access have the following meanings:

R/O Read Only, value can only be read

R/W Read/Write, value can be read and written

The number of characters specified under Data type in the case of character strings includes the final \0.

Char10 means that the text is up to 9 characters long. The final \0 character is then added to this

User level

| Address | Access | Data type | Signal reference | Parameter |
|---------|--------|-----------|------------------|--------------------------------|
| 0x0000 | R/O | Float | X1 | Analog input InP1 |
| 0x0002 | R/O | Float | X2 | Analog input InP2 |
| 0x0004 | R/O | Float | X3 | Analog input InP2 |
| 0x0006 | R/O | Float | WR | Actual setpoint |
| 0x0008 | R/W | Float | SP1 | Setpoint 1 |
| 0x000A | R/W | Float | SP2 (= dSP) | Setpoint 2 |
| 0x1035 | R/O | Float | --- | Analog input InP3 (unfiltered) |
| 0x1043 | R/O | Float | --- | Actual angular positioning |
| 0x1058 | R/O | Word | B1 | Burner alarm |

Parameter level

| Address | Access | Data type | Signal reference | Parameter |
|---------|--------|-----------|------------------|-------------------------------------|
| 0x3000 | R/W | Float | Pb1 | Proportional range 1 |
| 0x3004 | R/W | Float | dt | Derivative action time |
| 0x3006 | R/W | Float | rt | Integral action time |
| 0x300C | R/W | Float | db | Dead band |
| 0x3012 | R/W | Word | tt | Controlling element running time |
| | | | | |
| 0x3016 | R/W | Float | HYS1 | Switch-on threshold |
| 0x3018 | R/W | Float | HYS2 | Switch-off threshold down |
| 0x301A | R/W | Float | HYS3 | Switch-off threshold up |
| 0x301C | R/W | Float | HYS4 | Switch-on threshold (cooling) |
| 0x301E | R/W | Float | HYS5 | Switch-off threshold down (cooling) |
| 0x3020 | R/W | Float | HYS6 | Switch-off threshold up (cooling) |
| 0x3022 | R/W | Float | q | Reaction threshold |
| | | | | |
| 0x3080 | R/W | Float | At1 | Outside temperature 1 |
| 0x3082 | R/W | Float | Ht2 | Boiler temperature 1 |
| 0x3084 | R/W | Float | At2 | Outside temperature 2 |
| 0x3086 | R/W | Float | Ht2 | Boiler temperature 2 |

Configuration level

| Address | Access | Data type | Signal reference | Parameter |
|---------|--------|-----------|------------------|---|
| 0x3426 | R/W | Float | SCL1 | Start of display input 1 |
| 0x3428 | R/W | Float | SCH1 | End of display input 1 |
| 0x3432 | R/W | Float | SCL2 | Start value input 2 |
| 0x3434 | R/W | Float | SCH2 | End value input 2 |
| 0x3486 | R/W | Float | SPL | Start of setpoint limitation |
| 0x3488 | R/W | Float | SPH | End of setpoint limitation |
| 0x342A | R/W | Float | OFFS1 | Offset input E1 |
| 0x3436 | R/W | Float | OFFS2 | Offset input E2 |
| 0x343A | R/W | Float | OFFS3 | Offset input E3 |
| | | | | |
| 0x1063 | R/W | Word | FnCt | Ramp function |
| 0x1065 | R/W | Float | rASL | Ramp slope |
| 0x1067 | R/W | Float | toLP | Tolerance band ramp |
| 0x1069 | R/W | Float | rAL | Limit value |
| 0x1075 | R/W | Float | dtT | Remote Detection Timer |
| | | | | |
| 0x1077 | R/W | Float | dF1 | Filter constant input 1 |
| 0x1079 | R/W | Float | dF2 | Filter constant input 2 |
| 0x107B | R/W | Float | dF3 | Filter constant input 3 |
| 0x107D | R/O | Float | oLLo | Lower working range limit |
| 0x107F | R/O | Float | oLHi | Upper working range limit |
| | | | | |
| 0x106D | R/W | Word | FnCt | Alarm relay function |
| 0x106F | R/W | Float | AL | Alarm relay limit value (limit value alarm) |
| 0x1071 | R/W | Float | HYSt | Alarm relay hysteresis |

Remote operation

| Address | Access | Data type | Signal reference | Parameter |
|---------|--------|-----------|------------------|---|
| 0x0500 | R/W | Word | REM | Activation remote operation * |
| 0x0501 | R/W | Word | rOFF | Controller OFF in remote setpoint ** |
| 0x0502 | R/W | Float | rHYS1 | Switch-on threshold remote |
| 0x0504 | R/W | Float | rHYS2 | Switch-off threshold down remote |
| 0x0506 | R/W | Float | rHYS3 | Switch-off threshold up remote |
| 0x0508 | R/W | Float | SPr | Setpoint remote |
| | | | | |
| 0x050A | R/W | Word | RK1 | Burner release remote operation |
| 0x050B | R/W | Word | RK2 | Relay K2 remote operation |
| 0x050C | R/W | Word | RK3 | Relay K3 remote operation |
| 0x050D | R/W | Word | RK6 | Relay K6 remote operation |
| 0x050E | R/W | Word | rStEP | Step-by-step control remote operation |
| 0x050F | R/W | Float | rY | Angular positioning output remote operation |
| 0x0511 | R/W | Float | rHYS4 | Switch-on threshold remote (cooling) |
| 0x0513 | R/W | Float | rHYS5 | Switch-off threshold down remote (cooling) |
| 0x0515 | R/W | Float | rHYS6 | Switch-off threshold up remote (cooling) |

Legend

* = Local

** = Controller OFF

Dati dell'apparecchio

| Address | Access | Data type | Signal reference | Parameter |
|---------|--------|-----------|------------------|------------------|
| 0x8000 | R/O | Char12 | --- | Software version |
| 0x8006 | R/O | Char14 | --- | VdN number |

Stato dell'apparecchio

| Address | Access | Data type | Signal reference | Parameter |
|---------|--------|-----------|------------------|---------------------------------------|
| 0x0200 | R/O | Word | --- | Outputs and states |
| | | | Bit 0 | Output 1 |
| | | | Bit 1 | Output 3 |
| | | | Bit 2 | Output 2 |
| | | | Bit 3 | Output 4 |
| | | | Bit 8 | Hysteresis limitation |
| | | | Bit 9 | Control system |
| | | | Bit 10 | Self-optimization |
| | | | Bit 11 | Second setpoint |
| | | | Bit 12 | Measuring range overshoot InP1 |
| | | | Bit 13 | Measuring range overshoot InP2 |
| | | | Bit 14 | Measuring range overshoot InP3 |
| | | | Bit 15 | Calibration mode |
| 0x0201 | R/O | Word | --- | Binary signals and hardware detection |
| | | | Bit 0 | Operation mode 2-stage |
| | | | Bit 1 | Manual mode |
| | | | Bit 2 | Binary input D1 |
| | | | Bit 3 | Binary input D2 |
| | | | Bit 4 | Thermostat function |
| | | | Bit 5 | First controller output |
| | | | Bit 6 | Second controller output |
| | | | Bit 7 | Alarm relay |
| | | | Bit 13 | Analog output available |
| | | | Bit 14 | Interface available |

Electric connections :

With 7 pins connector version

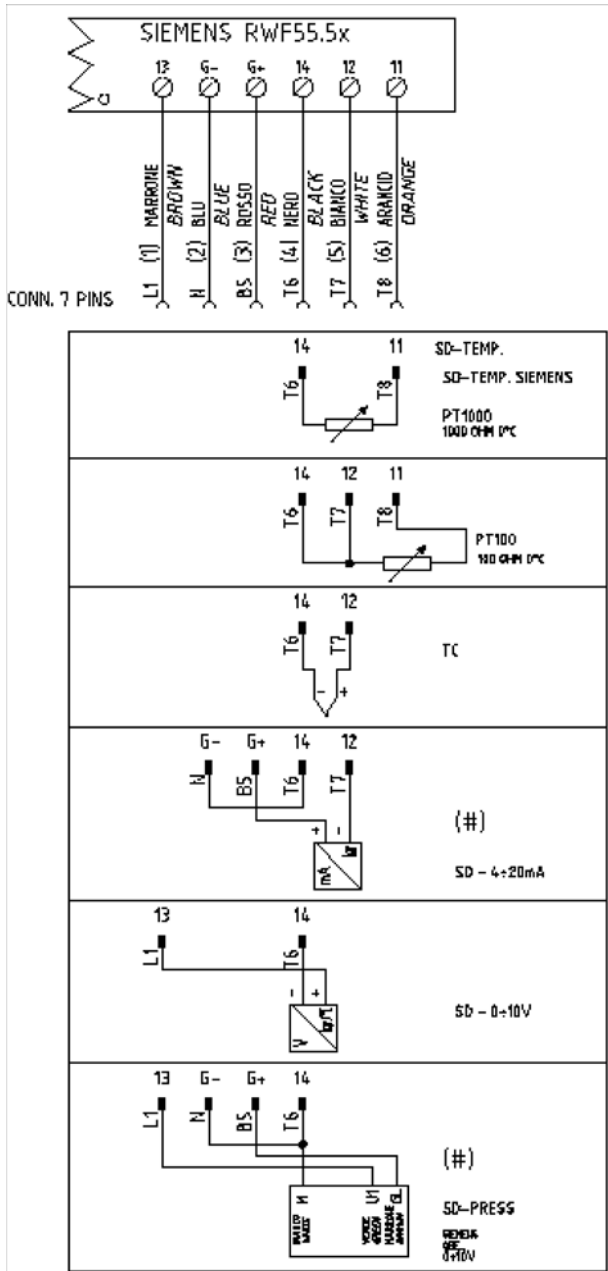

With terminals version

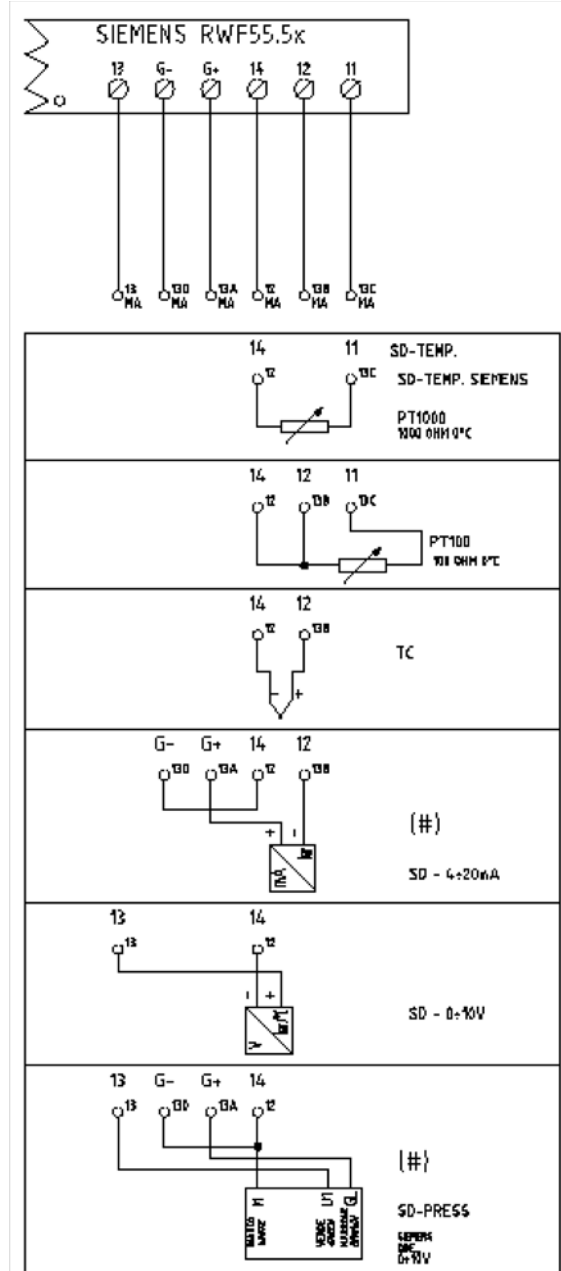

Correspondences bornes entre RWF55.5x y RWF40.0x0 Matches terminals between RWF55.5x and RWF40.0x0

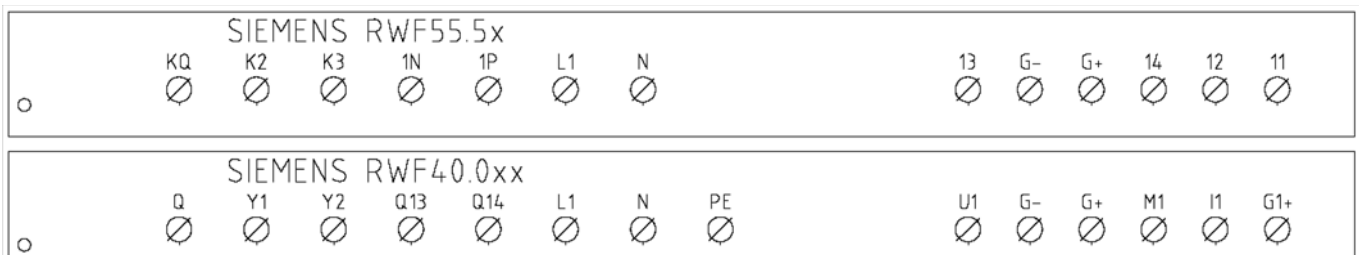

Parameters summarising for RWF55.xx :

| Navigation menu | ConF | | | | | ConF | | | PArA | | | | | | Opr |
|------------------------|------|------|----------|----------|----------|----------|----------|----------|-------|----|-----|-----|----------|----------|-------------|
| | Inp | | | | | | | diSP | | | | | | | |
| | Inp1 | | | | | Cntr | | dECP | | | | | | | |
| | SEn1 | OFF1 | SCL | SCH | Unit | SPL | SPH | dECP | Pb. 1 | dt | rt | tt | HYS1 (*) | HYS3 (*) | SP1 (*) |
| Siemens QAE2120... | 6 | 0 | needless | needless | 1 | 30 | 95 | 1 | 10 | 80 | 350 | (#) | -5 | 5 | 80 °C |
| Siemens QAM2120.. | 6 | 0 | needless | needless | 1 | 0 | 80 | 1 | 10 | 80 | 350 | (#) | -2,5 | 2,5 | 40°C |
| Pt1000 (130°C max.) | 4 | 0 | needless | needless | 1 | 30 | 95 | 1 | 10 | 80 | 350 | (#) | -5 | 5 | 80°C |
| Pt1000 (350°C max.) | 4 | 0 | needless | needless | 1 | 0 | 350 | 1 | 10 | 80 | 350 | (#) | -5 | 10 | 80°C |
| Pt100 (130°C max.) | 1 | 0 | needless | needless | 1 | 0 | 95 | 1 | 10 | 80 | 350 | (#) | -5 | 5 | 80°C |
| Pt100 (350°C max) | 1 | 0 | needless | needless | 1 | 0 | 350 | 1 | 10 | 80 | 350 | (#) | -5 | 10 | 80°C |
| Probe4+20mA / 0+1,6bar | 16 | 0 | 0 | 160 | needless | 0 | 160 | 0 | 5 | 20 | 80 | (#) | 0 | 20 | 100 kPa |
| Probe4+20mA / 0+3bar | 16 | 0 | 0 | 300 | needless | 0 | 300 | 0 | 5 | 20 | 80 | (#) | 0 | 20 | 200 kPa |
| Probe 4+20mA / 0+10bar | 16 | 0 | 0 | 1000 | needless | 0 | 1000 | 0 | 5 | 20 | 80 | (#) | 0 | 50 | 600 kPa |
| Probe 4+20mA / 0+16bar | 16 | 0 | 0 | 1600 | needless | 0 | 1600 | 0 | 5 | 20 | 80 | (#) | 0 | 80 | 600 kPa |
| Probe 4+20mA / 0+25bar | 16 | 0 | 0 | 2500 | needless | 0 | 2500 | 0 | 5 | 20 | 80 | (#) | 0 | 125 | 600 kPa |
| Probe 4+20mA / 0+40bar | 16 | 0 | 0 | 4000 | needless | 0 | 4000 | 0 | 5 | 20 | 80 | (#) | 0 | 200 | 600 kPa |
| Probe 4+20mA / 0+60PSI | 16 | 0 | 0 | 600 | needless | 0 | 600 | 0 | 5 | 20 | 80 | (#) | 0 | 30 | 300 (30PSI) |
| Probe4+20mA / 0+200PSI | 16 | 0 | 0 | 2000 | needless | 0 | 2000 | 0 | 5 | 20 | 80 | (#) | 0 | 75 | 600 (60PSI) |
| Probe4+20mA / 0+300PSI | 16 | 0 | 0 | 3000 | needless | 0 | 3000 | 0 | 5 | 20 | 80 | (#) | 0 | 120 | 600 (60PSI) |
| Siemens QBE2002 P4 | 17 | 0 | 0 | 400 | needless | 0 | 400 | 0 | 5 | 20 | 80 | (#) | 0 | 20 | 200 kPa |
| Siemens QBE2002 P10 | 17 | 0 | 0 | 1000 | needless | 0 | 1000 | 0 | 5 | 20 | 80 | (#) | 0 | 50 | 600 kPa |
| Siemens QBE2002 P16 | 17 | 0 | 0 | 1600 | needless | 0 | 1600 | 0 | 5 | 20 | 80 | (#) | 0 | 80 | 600 kPa |
| Siemens QBE2002 P25 | 17 | 0 | 0 | 2500 | needless | 0 | 2500 | 0 | 5 | 20 | 80 | (#) | 0 | 125 | 600 kPa |
| Siemens QBE2002 P40 | 17 | 0 | 0 | 4000 | needless | 0 | 4000 | 0 | 5 | 20 | 80 | (#) | 0 | 200 | 600 kPa |
| Signal 0+10V | 17 | 0 | needless | needless | needless | needless | needless | needless | 5 | 20 | 80 | (#) | | | |
| Signal 4+20mA | 16 | 0 | needless | needless | needless | needless | needless | needless | 5 | 20 | 80 | (#) | | | |

NOTE:

(#) tt – servo control run time

SQL33 ; STM30; SQM10; SQM40; SQM50; SQM54 = 30 (secondi) - STA12B3.41; SQN30.251; SQN72.4A4A20 = 12 (secondi)

(*)These values are factory set - values must be set during operation at the plant based on the real working temperature/pressure value.

WARNING :

With pressure probes in bar the parameters SP1, SCH, SCL, HYS1, HYS3 must be set and displayed in kPa (kilo Pascal); 1bar = 100,000Pa = 100kPa.

With pressure probes in PSI the parameters SP1, SCH, SCL, HYS1, HYS3 must be set and displayed in PSI x10 (example: 150PSI > I display 1500).

APPENDIX: PROBES CONNECTION

To assure the utmost comfort, the control system needs reliable information, which can be obtained provided the sensors have been installed correctly. Sensors measure and transmit all variations encountered at their location.

Measurement is taken based on design features (time constant) and according to specific operating conditions. With wiring run in raceways, the sheath (or pipe) containing the wires must be plugged at the sensor's terminal board so that currents of air cannot affect the sensor's measurements.

Ambient probes (or ambient thermostats)

Installation

The sensors (or room thermostats) must be located in reference rooms in a position where they can take real temperature measurements without being affected by foreign factors.

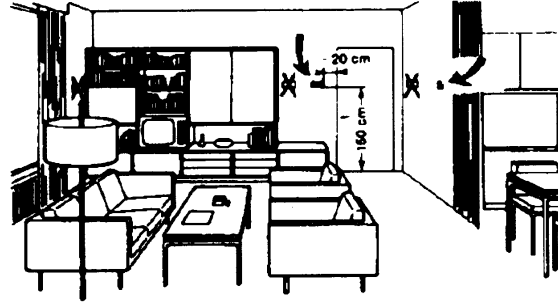
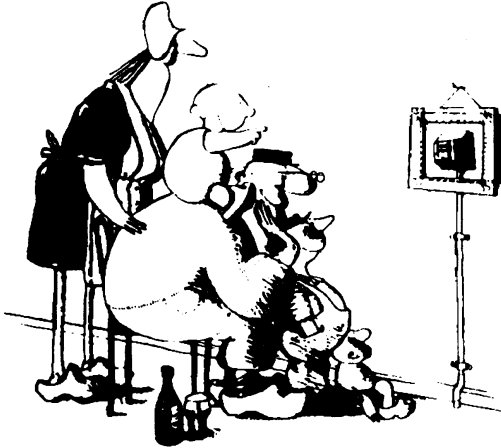

Outside probes (weather) Installation

In heating or air-conditioning systems featuring adjustment in response to outside temperature, the sensor's positioning is of paramount importance.

It's good to be admired ...even better to be effective

Heating systems: the room sensor must not be installed in rooms with heating units complete with thermostatic valves. Avoid all sources of heat foreign to the system.

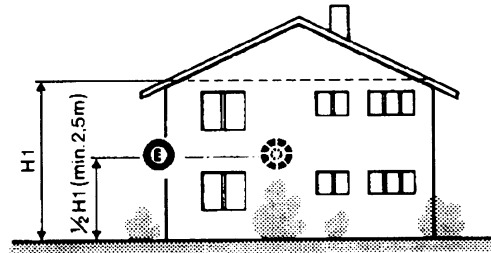
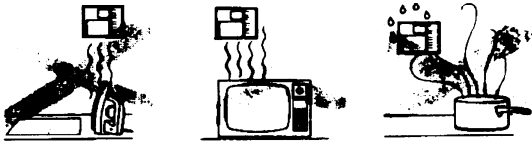

General rule: en on the outer wall of the building where the living rooms are, never on the south-facing wall or in a position where they will be affected by morning sun. If in any doubt, place them on the north or north-east façade.

Positions to be avoided

Location

On an inner wall on the other side of the room to heating units height above floor 1.5 m, at least 1.5 m away from external sources of heat (or cold).

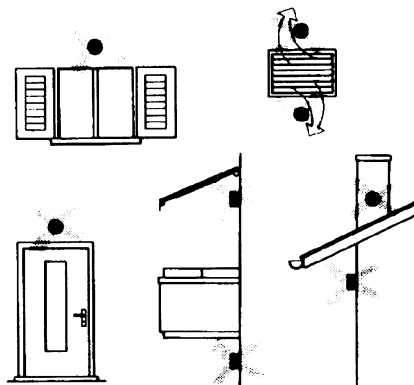
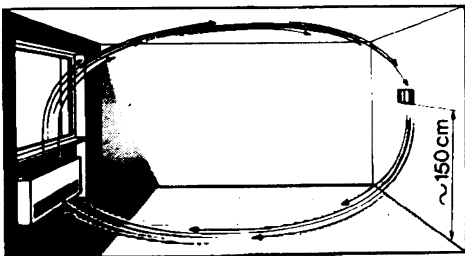

Installation position to be avoided

near shelving or alcoves and recesses, near doors or windows, inside outer walls exposed to solar radiation or currents of cold air, on inner walls with heating system pipes, domestic hot water pipes, or cooling system pipes running through them.

Avoid installing near windows, vents, outside the boiler room, on chimney breasts or where they are protected by balconies, cantilever roofs .

The sensor must not be painted (measurement error) .

Duct or pipe sensors

Installing temperature sensors

For measuring outlet air:

"after delivery fan or

"after coil to be controlled, at a distance of at least 0,5 m

For measuring room temperature:

"before return air intake fan and near room's return airintake.

For measuring saturation temperature: after mist eliminator.

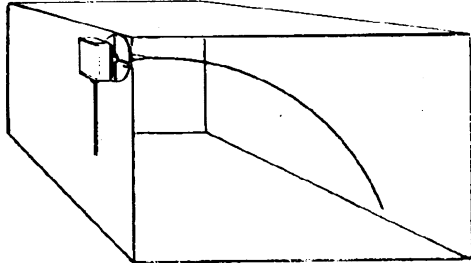

Bend 0.4m sensor by hand (never use tools) as illustrated .

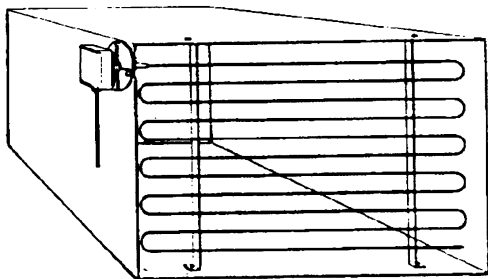

Use whole cross-section of duct, min. distance from walls 50 mm, radius of curvature 10 mm for 2m or 6m sensors

Installing combined humidity sensors

As max. humidity limit sensor on outlet (steam humidifiers) .

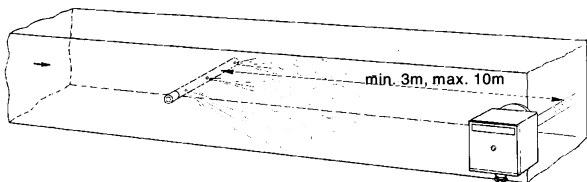

Installing pressure sensors

A - installation on ducts carrying fluids at max. temperature 80°C

B - installation on ducts at temperature over 80°C and for refrigerants

C - installation on ducts at high temperatures :

· "increase length of siphon

"place sensor at side to prevent it being hit by hot air coming from the pipe.

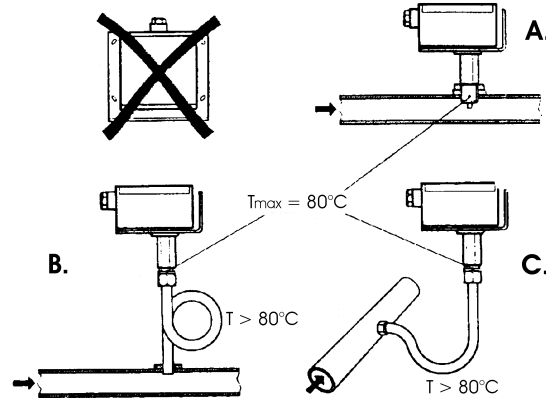

Installing differential pressure sensors for water

Installation with casing facing down not allowed.

With temperature over 80°C, siphons are needed.

To avoid damaging the sensor, you must comply with the following instructions :

when installing: make sure pressure difference is not greater than the value permitted by the sensor

when there are high static pressures, make sure you insert shutoff valves A-B-C.

Putting into operation

Start disable

1=open C1=open C

2=open A2=close B

3=open B3=close A

4= close C

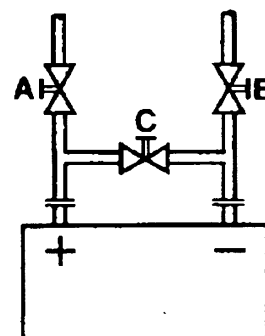

Immersion or strap-on sensors

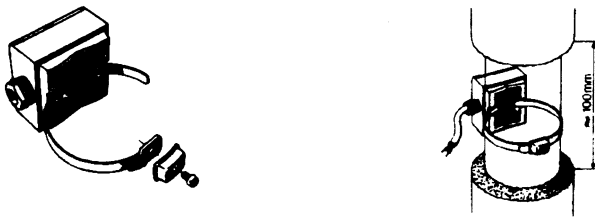
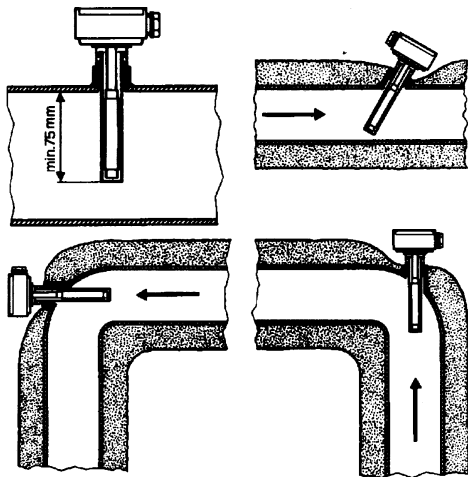

Immersion probes installation

Sensors must be installed on the stretch of pipe in which fluid circulates all the time.

The rigid stem (sensing element doing the measuring) must be inserted by at least 75mm and must face the direction of flow.

Recommended locations: on a bend or on a straight stretch of pipe but tilted by 45° and against the flow of fluid.

Protect them to prevent water from infiltrating (dripping gates, condensation from pipes etc.) .

Installing QAD2.. strap-on sensors

Make sure fluid is circulating in the chosen location.

Eliminate insulation and paintwork (including rust inhibitor) on a min. 100mm length of pipe.

Sensors come with straps for pipes up to 100 mm in diameter .

Placing the probes (QAD22.../QAE21.../QAP21.../RCA...)

With pumps on outlet

with 3 ways valves / with 4 ways valves



Panel system / burner control

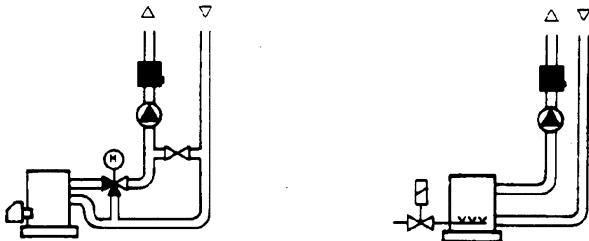

With pumps on return

with 3 ways valves / with 4 ways valves



Strap-on or immersion sensors?

QAD2.. strap-on sensors

Advantages :

- 10 sec. time constant
- Installed with system running (no plumbing work)
- Installation can be changed easily if it proves incorrect

ΠLimits:

- Suitable for pipe diameters max. 100 mm
- Can be affected by currents of air etc.

QAE2... immersion sensors

Advantages:

- Measure "mean" fluid temperature
- No external influence on measurement such as: currents of air, nearby pipes etc.

Limits:

- Time constant with sheath: 20 sec.
- Hard to change installation position if it proves incorrect

Installing differential pressure probes for air

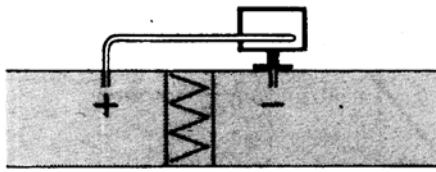

A - Control a filter (clogging)

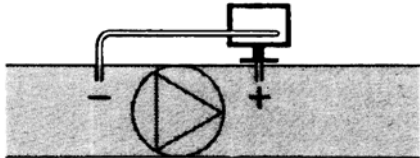

B - Control a fan (upstream/downstream)

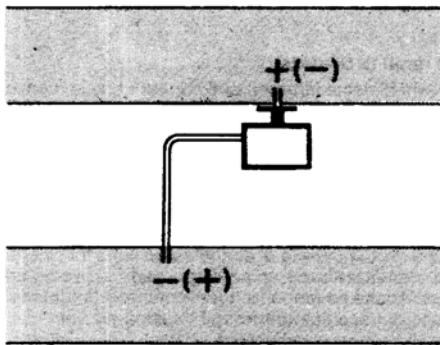

C - Measurement of difference in pressure between two ducts

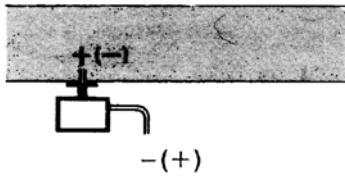

D - Measurement of difference in pressure between two rooms or of inside of duct and outside

Basic principles

Measuring static pressure (i.e. pressure exerted by air on pipe walls)

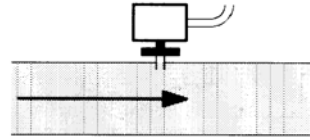

Measuring dynamic pressure

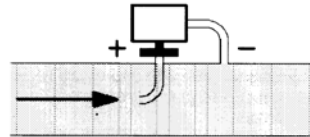

$$P_d = \frac{\gamma v^2}{2g}$$

Legend

- y Kg/m³, specific weight of air
- q m/s, air speed
- g 9.81 m/s² gravity acceleration
- P_d mm C.A., dynamic pressure

Measuring total pressure

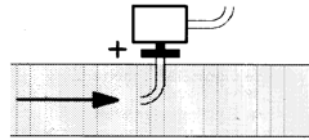

Note: Specifications and data subject to change. Errors and omissions excepted.

RWF55.5X & RWF55.6X



User manual

DEVICE INSTALLATION

Fixing system

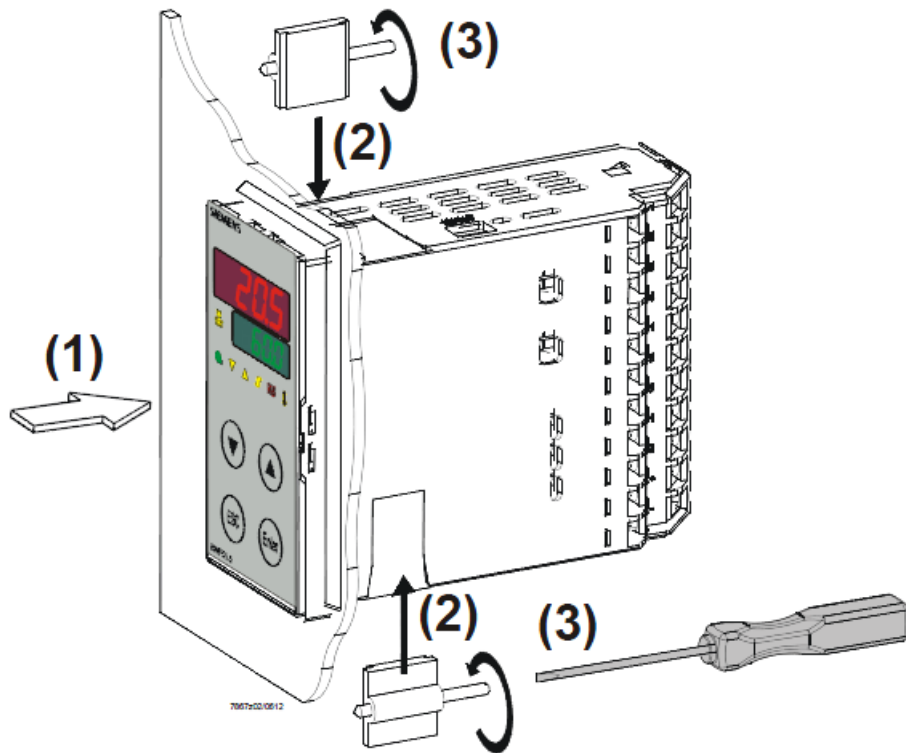

Drilling dimensions:

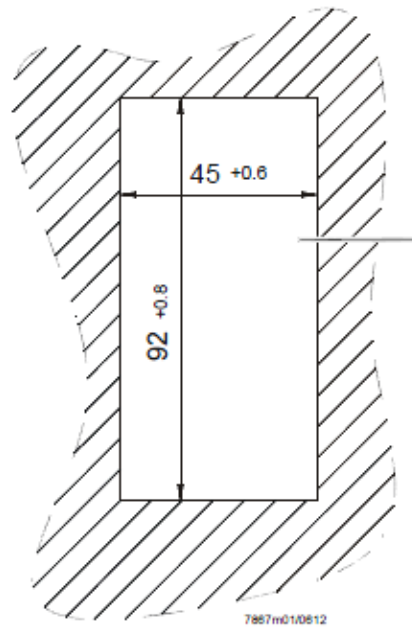

FRONT PANEL

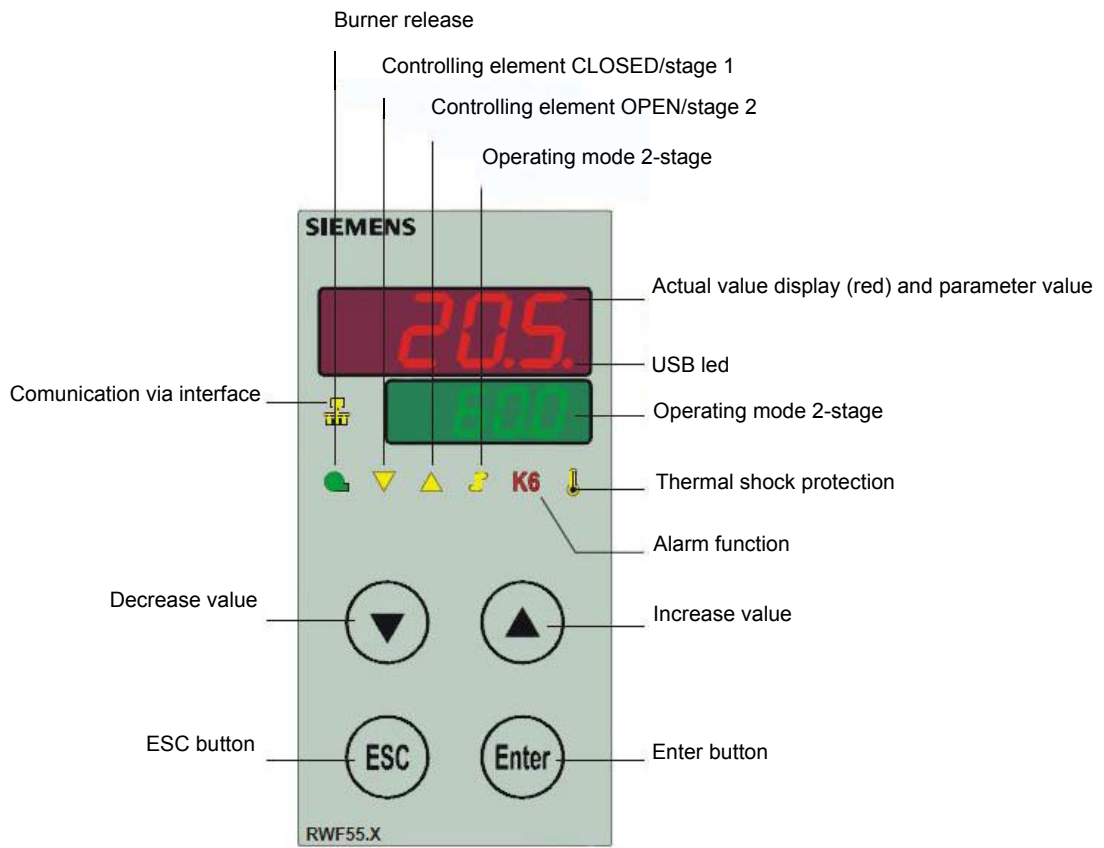

NAVIGATION MENU

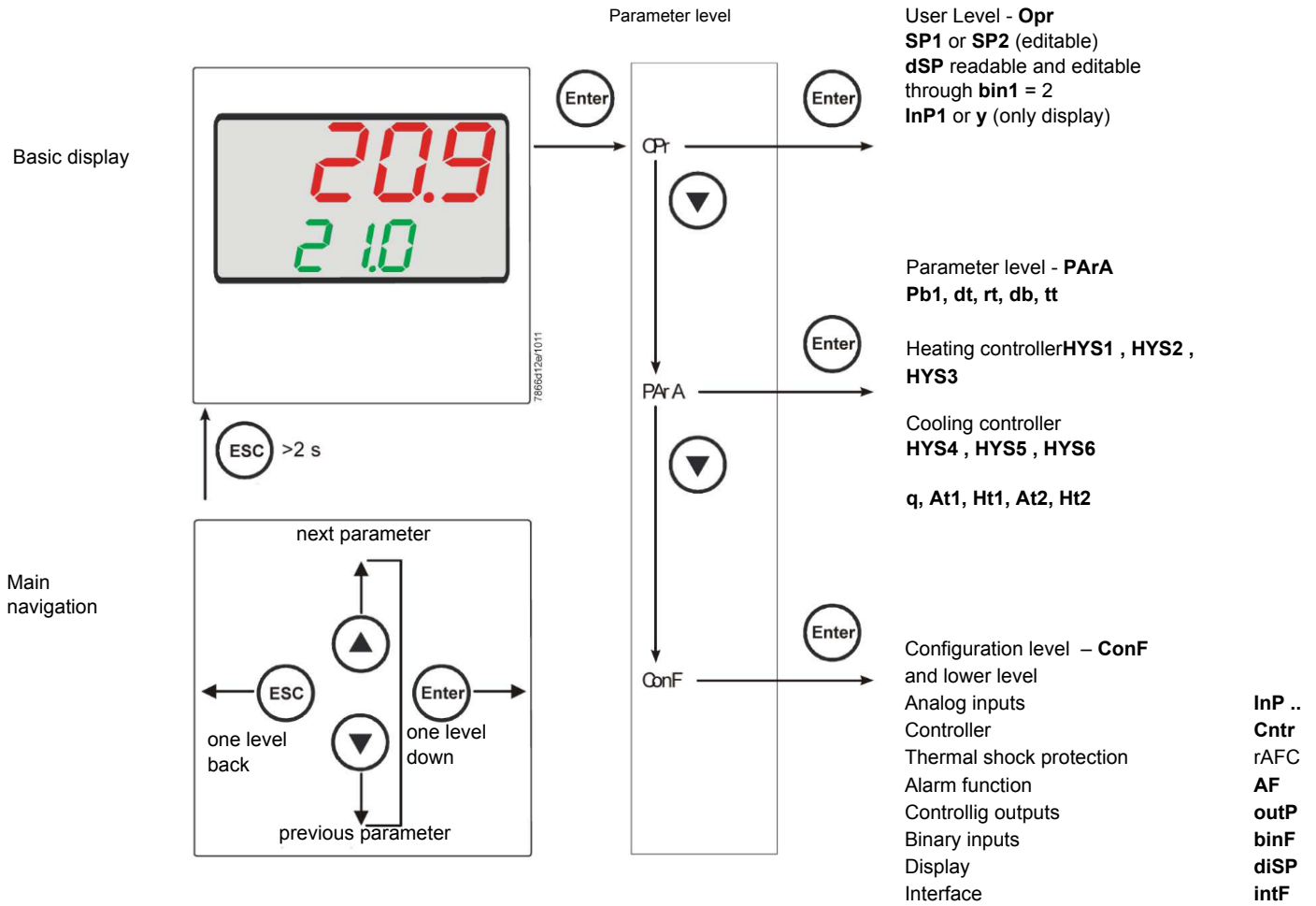

RWF55 is preset good for 90% of applications. However, you can set or edit parameters as follow:

Set-point: set or modification:

When the burner is in stand-by, (safety loop open, that is terminals 3-4/T1-T2 on the 7 pole plug open) push the Enter button: on the lower display (green) Opr appears; push Enter again and in the same display SP1 appears. Push Enter again and the lower display (green SP1) flashes. Using the up and down arrows change the set-point on the upper display (red).Push Enter to confirm and push ESC more times to get the home position.

PID parameters set and modifications (PARA):

Push **Enter** button, on the green display **Opr** appears; using the **down arrow**, scroll until group **PARA** is reached and push **Enter**.
On the green display **Pb1** e appears and on the red one the set parameter. Push is sequence the **down or up** arrow the menu is scrolled.
Push **Enter** to select and the **arrows** to choose the desired value. **Enter** to confirm

| Parameter | Display | Range | Factory setting | Remarks |
|--|---------|--------------------|-----------------|---|
| Proportional band | Pb1 | 1... 9999 digit | 10 | Typical value for temperature |
| Derivative action | dt | 0... 9999 sec. | 80 | Typical value for temperature |
| Integral action | rt | 0... 9999 sec. | 350 | Typical value for temperature T |
| Dead band (*) | db | 0... 999,9 digit | 1 | Typical value |
| Servocontrol running time | tt | 10... 3000 sec. | 15 | Set servocontrol running time |
| Switch-on differential (*) | HYS1 | 0,0... -1999 digit | -5 | Value under setpoint below which the burner switches back on (1N-1P closes) |
| Switch-off differential 2° stage (*) | HYS2 | 0,0 ... HYS3 | 3 | (enable only with parameter bin1 = 4) |
| Upper switch-off differential (*) | HYS3 | 0,0... 9999 digit | 5 | Value over setpoint above which the burner switches off (1N-1P opens) |
| Switch-on differential on cooling controller (*) | HYS4 | 0,0... 9999 digit | 5 | Do not used (enable only with parameter CACT = 0) |
| Switch-off differential 2° stage on cooling controller (*) | HYS5 | HYS6...0,0 digit | 5 | Do not used (enable only with parameter CACT = 0 and parameter bin1 =0) |
| Upper switch-off differential on cooling controller (*) | HYS6 | 0,0... -1999 digit | 5 | Do not used (enable only with parameter CACT = 0) |
| Delay modulation | q | 0,0... 999,9 digit | 0 | Do not alter |
| T Outside temperature Curve point 1 (*) | At1 | -40 ...120 digit | -10 | First point of external temperature for climatic curve |
| Boiler temperature Curve point 1 (*) | Ht1 | SPL...SPH | 60 | Set-point temperature for the external temperature 1 |
| TT Outside temperature Curve point 2 (*) | At2 | -40 ...120 digit | 20 | Second point of external temperature for climatic curve |
| Boiler temperature Curve point 2 (*) | Ht2 | SPL...SPH | 50 | Set-point temperature for the external temperature 2 |

(*) Parameters affected by setting of decimal place (**ConF** > **dISP** parameter **dECP**)

Setting the kind of sensor to be connected to the device:

Push the **Enter** button: on the lower display (green) **Opr** appears. Using the **up and down arrows** find **ConF**. Push **Enter** to confirm. Now on the green display the group **InP** appears. Push **Enter** and **InP1** is displayed. Enter to confirm. You are inside **InP1**; the green display shows **Sen1 (sensor type)**, while the red display shows the chosen sensor code Push **Enter** to enter the **Sen1** parameter, then choose the desired sensor using the **arrows**. Push **Enter** to confirm and **ESC** to escape.

Once selected the sensor, you can modify all the other parameters using **up and down arrows** according to the tables here below :

ConF > InP > InP1

| Parameter | Value | Description |
|--|-----------------------------|---|
| SEn1 type of sensor for analog input 1 | 1 | Pt100 3 wire |
| | 2 | Pt100 2 wire |
| | 3 | Pt1000 3 wire |
| | 4 | Pt1000 2 wire |
| | 5 | Ni1000 3 wire |
| | 6 | Ni1000 2 wire |
| | 7 | 0 ÷ 135 ohm |
| | 8 | Cu-CuNi T |
| | 9 | Fe-CuNi J |
| | 10 | NiCr-Ni K |
| | 11 | NiCrSi-NiSi N |
| | 12 | Pt10Rh-Pt S |
| | 13 | Pt13Rh-Pt R |
| | 14 | Pt30Rh-Pt6Rh B |
| | 15 | 0 ÷ 20mA |
| | 16 | 4 ÷ 20mA |
| | 17 | 0 ÷ 10V |
| | 18 | 0 ÷ 5V |
| | 19 | 1 ÷ 5V |
| OFF1 Sensor offset | -1999..0.. +9999 | Correction value measured by the sensor |
| SCL1 scale low level | -1999..0.. +9999 | minimum scale value(for input ohm, mA, V) |
| SCH1 scale high level | -1999.. 100 .. +9999 | maximum scale value(for input ohm, mA, V) |
| dF1 digital filter | 0... 0,6 ...100 | Is used to adapt the digital 2nd order input filter (time in s; 0 s = filter off) |
| Unit temperature unit | 1 | 1 = degrees Celsius |
| | 2 | 2 = degrees Fahrenheit |

(**bold** = factory settings)

ConF > InP > InP2

Input 2 : this input can be used to specify an external setpoint or carry out setpoint shifting

| Parameter | Value | Description |
|-----------------------------|-----------------------------|---|
| FnC2 | 0 | 0= no function |
| | 1 | 1= external setpoint (display SPE) |
| | 2 | 2 =setpoint shifting (display dSP) |
| | 3 | 3 = angular positioning feedback |
| SEn2 sensor type input 2 | 1 | 0 ÷ 20mA |
| | 2 | 4 ÷ 20mA |
| | 3 | 0 ÷ 10V |
| | 4 | 0 ÷ 5V |
| | 5 | 1 ÷ 5V |
| | 1 | 0 ÷ 20mA |
| OFF2 Sensor offset | -1999..0.. +9999 | Correction value measured by the sensor |
| SCL2 scale low level | -1999..0.. +9999 | minimum scale value(for input ohm, mA, V) |
| SCH2 scale high level | -1999.. 100 .. +9999 | maximum scale value(for input ohm, mA, V) |
| dF2 digital filter | 0... 2 ...100 | Is used to adapt the digital 2nd order input filter (time in s; 0 s = filter off) |

(**bold** = factory settings)

ConF > InP > InP3

Input 3: this input is used to acquire the outside temperature

| Parameter | Value | Description |
|--|--------------------------|---|
| SEn3 sensor type input 3 sensor type input 2 | 0 | 0 = |
| | 1 | 1 = wire |
| | 2 | 2 = wire |
| OFF3 Sensor offset | -1999..0.. +9999 | Correction value measured by the sensor |
| dF3 digital filter | 0... 1278 ...1500 | Is used to adapt the digital 2nd order input filter (time in s; 0 s = filter off) |

(**bold** = factory settings)

ConF > Cntr

Here, the type of controller, operating action, setpoint limits and presettings for self-optimization are selected

| Parameter | Value | Description |
|---|------------------|---|
| CtYP controller type | 1 2 | 1 = 3-position controller (open-stop-close) 2 = continuative action controller (0 ÷ 10V or 4 ÷ 20mA) |
| CACT control action | 1 0 | 1 = heating controller 0 = cooling controller |
| SPL least value of the set-point range | -1999..0..+9999 | minimum set-point scale |
| SPH maximum value of the set-point range | -1999..100..+999 | maximum set-point scale |
| Self-optimization | 0 1 | 0 = Free 1 = Locked Self-optimization can only be disabled or enabled via the ACS411 setup program. Self-optimization is also disabled when the parameter level is locked |
| oLLo set-point limitation start, operation limit low | -1999.... +9999 | lower working range limit |
| oLHi set-point limitation end, operation limit high | -1999.... +9999 | upper working range limit |

(bold = factory settings)

ConF > rAFC

Activation boiler shock termic protetion:

RWF55.. can activate the thermal shock protection only on sites where the set-point is lower than 250°C and according to rAL parameter

| Parameter | Value | Description |
|-----------------------------|------------------------|--|
| FnCT type of contol | 0 1 2 | choose type of range degrees/time 0 = deactivated 1 = Kelvin degrees/minute 2 = Kelvin degrees/hour |
| rASL ramp rate | 0,0 ... 999,9 | Slope of thermal shock protection (only with functions 1 and 2) |
| toLP tolerance band ramp | 2 x (HYS1) = 10...9999 | width of tolerance band (in K) about the set-point 0 = tolerance band inactive |
| rAL ramp limit | 0...250 | Ramp limit. When this value is lower than the temperature set-point, the RWF controls the output increasing the temp set point step by step according to rASL. If this is over the temp set point, the control is performed in cooling |

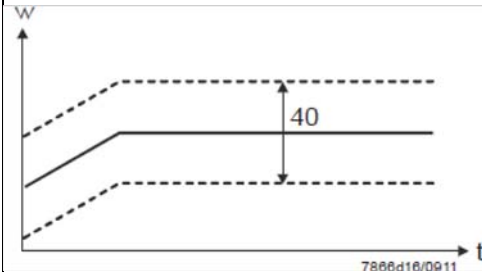

(bold = factory settings)

Alarm function AF

The alarm function can be used to monitor the analog inputs. If the limit value is exceeded, multifunctional relay K6 (terminals **6N** and **6P**) is activated (depending on the switching characteristic)

The alarm function can have different switching functions (Ik1 to Ik8) and can be set to a deviation from the active setpoint or to a fixed limit value

Limit value **AL** relative to setpoint (x)

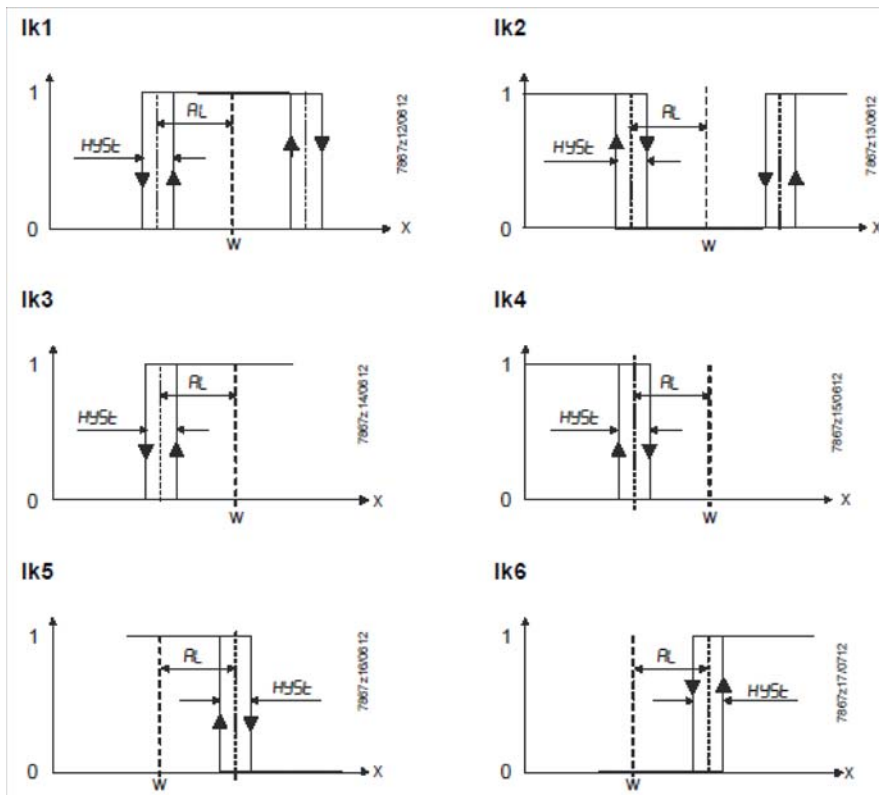

Fixed limit value **AL**

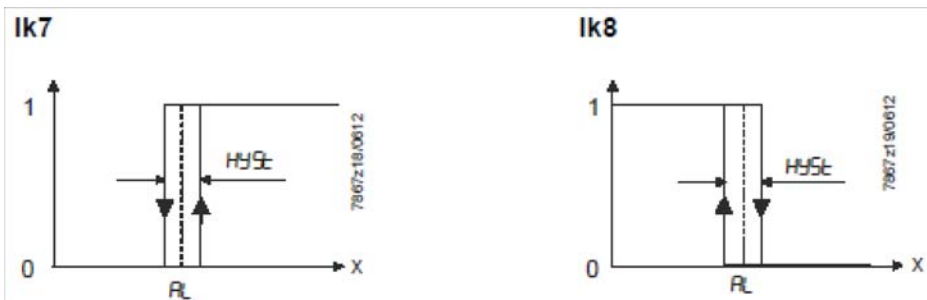

ConF > AF

| Parameter | Value | Description |
|----------------------------------|--|---|
| FnCt type of control | 0 1 2 3 4 5 6 7 8 9 10 11 12 | 0 = Without function lk1 = monitored input InP1 lk2 = monitored input InP1 lk3 = monitored input InP1 lk4 = monitored input InP1 lk5 = monitored input InP1 lk6 = monitored input InP1 lk7 = monitored input InP1 lk8 = monitored input InP1 lk7 = monitored input InP2 lk8 = monitored input InP2 lk7 = monitored input InP3 lk8 = monitored input InP3 |
| Alarm value AL | -1999 ... 0 1999 | Limit value or deviation from setpoint to be monitored (see alarm functions lk1 to lk8 : limit value AL) Limit value range for lk1 and lk20 ...9999 |
| HySt switching differential | 0... 1... 9999 | Switching differential for limit value AL |
| ACrA response by out of range | 0 1 | Switched-off ON Switching state in the case of measuring range overshoot or undershoot (Out of Range) |

(**bold** = factory settings)

ConF > OutP

For fuel-air ratio control purposes, the RWF55 has the binary outputs K2, K3 (terminals KQ, K2, K3) and the analog output (terminals A+, A-). The burner is released via relay K1 (terminals 1N, 1P).

The binary outputs of the RWF55 offer no setting choices

The RWF55 has an analog output.

The analog output offers the following setting choices:

| Parameter | Value | Description |
|---------------------------------------|------------------------------|---|
| FnCt type of control | 1 2 3 4 | 1 = analog input 1 doubling with possibility to convert 2 = analog input 2 doubling with possibility to convert 3 = analog input 3 doubling with possibility to convert 4 = Controller's angular positioning is delivered (modulating controller) |
| SiGn type of output signal | 0 1 2 | physical output signal (terminals A+, A-) 0 = 0÷20mA 1 = 4÷20mA 2 = 0÷10V DC |
| rOut value when out of input range | 0 ...101 | signal (in percent) when measurement range is crossed |
| oPnt zero point | -1999... 0 ...+9999 | A value range of the output variable is assigned to a physical output signal (for FnCt = 1, 2, 3) |
| End end point | -1999... 100 ...+9999 | A value range of the output variable is assigned to a physical output signal (for FnCt = 1, 2, 3) |

(**bold** = factory settings)

ConF > binF

This setting decides on the use of the binary inputs **D1**, **D2**, **DG**

b

| Parameter | Value | Description |
|---|-------------------------|--|
| bin1 binary input 1 (terminals DG – D1) | 0 1 2 3 | 0 = without function 1 = set-point changeover (SP1 / SP2) 2 = Iset-point shift (Opr > dSP parameter = value of set-point modify) 3 = input alarm |
| bin2 binary input 2 (terminals DG – D2) | 4 | changeover of operating mode DG-D2 open = modulating operation DG-D2 close = 2 stage operation |

(**bold** = factory settings)

ConF > dISP

.Both displays can be customized to suit your needs by configuring the displayed value, decimal, time out and blocking

| Parameter | Value | Description |
|-------------------------------|---|--|
| diSU upper display (red) | 0 1 2 3 4 6 7 | Display value for upper display: 0 = display power-off 1 = analog input 1 (InP1) value 2 = analog input 2 (InP2) value 3 = analog input 3 (InP3) value 4 = controller's angular positioning 6 = set-point values 7 = end value with thermal shock protection |
| diSL lower display (green) | 0 1 2 3 4 6 7 | Display value for lower display: 0 = display power-off 1 = analog input 2 (InP2) value 2 = analog input 2 (InP2) value 3 = analog input 2 (InP2) value 4 = controller's angular positioning 6 = set-point values 7 = end value with thermal shock protection |
| tout timeout | 0.. 180 ..250 | time (s) on completion of which the controller returns automatically to the basic display, if no button is pressed |
| dECP decimal point | 0 1 2 | 0 = no decimal place 1 = one decimal place 2 = two decimal place |
| CodE level lockout | 0 1 2 3 | 0 = no lockout 1 = configuration level lockout (ConF) 2 = parameter and configuration level lockout (PARa & ConF) 3 = keyboard lockout |

(**bold** = factory settings)

ConF > IntF

The controller can be integrated into a data network using an optional RS-485 (terminals R+ and R-) interface or an optional Profibus DP interface(only model **RWF55.6x** terminals C1-C2-C3-C4)

| Parameter | Value | Description |
|-------------------------|----------------|-----------------------------|
| bdrt | 0 | 0 = 4800 baud |
| baudrate | 1 | 1 = 9600 baud |
| | 2 | 2 = 19200 baud |
| | 3 | 3 = 38400 baud |
| | | |
| Adr | 0.. | Address in the data network |
| Device address Modbus | 1.. | |
| | 254 | |
| dP | 0.. 125 | only with RWF55.6x |
| Device address Profibus | | |
| dt | 0.. | 0 = switched-off |
| Remote detection time | 30 .. | |
| | 7200s | |

(**bold** = factory settings)

Manual control :

In order to manual change the burner load, while firing keep pushing the **ESC** button for more than 5 s; on the lower green display **Hand** appears.

using the **UP** and **DOWN** arrows, the load varies.

Keep pushing the **ESC** button for getting the normal operation again.

NB: every time the device shuts the burner down (start led switched off - contact 1N-1P open), the manual control is not active.

Device self-setting (auto-tuning):

If the burner in the steady state does not respond properly to heat generator requests, you can activate the Device's self-setting function, which recalculates PID values for its operation, deciding which are most suitable for the specific kind of request



Follow the below instructions:

push the **UP** and **DOWN** arrows for more than 5 s; on the green lower display **tUnE** appears. Now the device pushes the burner to increase and decrease its output. During this time, the device calculates **PID** parameters (**Pb1**, **dt** and **rt**). After the calculations, the **tUnE** is automatically deactivated and the device has already stored them.

In order to stop the Auto-tuning function while it works, push again the **UP** and **DOWN** arrows for more than 5 s. The calculated **PID** parameters can be manually modified following the previously described instructions.

Display of software version :

The software version is shown by pushing Enter + UP arrow on the upper display.



Weather-compensated setpoint shifting (climatic regulation):

The RWF55 can be configured so that weather-compensated setpoint shifting is activated when an LG-Ni1000 outside sensor or a Pt1000 is connected (see parameter **InP3**).

To take into account the time response of a building, weather-compensated setpoint shifting uses the attenuated outside temperature rather than the current outside temperature.

The minimum and maximum setpoints can be set using the lower setpoint limit **SPL** and the upper setpoint limit **SPH** of the menu **Crtr**.

The system also prevents the lower working range limit **oLLo** and upper working range limit **oLHi** from exceeding/dropping below the system temperature limits.

The heating curve describes the relationship between the boiler temperature setpoint and the outside temperature. It is defined by 2 curve points. For 2 outside temperatures, the user defines the boiler temperature setpoint that is required in each case. The heating curve for the weather-compensated setpoint is calculated on this basis. The effective boiler temperature setpoint is limited by the upper setpoint limit **SPH** and the lower setpoint limit **SPL**.

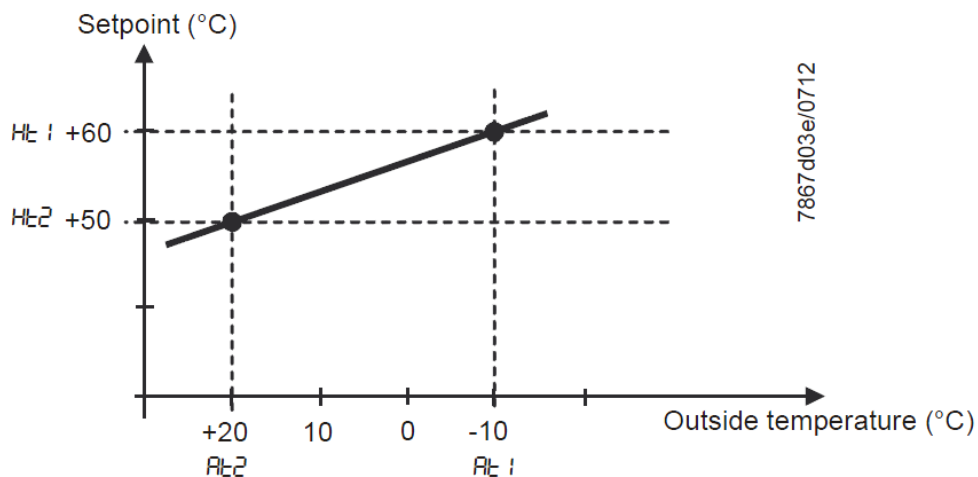

For setting climatic regulation function set:

PArA > parameters **At1**, **Ht1**, **At2**, **Ht2**

ConF > **InP** > **InP3** parameters **SEn3**, **FnC3** = 1 (Weather-compensated setpoint).

Modbus interface

The tables that follow in this chapter specify the addresses of the readable and writable words that the customer is able to access. The customer may read and/or write the values using SCADA programs, PLCs, or similar.

The entries under Access have the following meanings:

R/O Read Only, value can only be read

R/W Read/Write, value can be read and written

The number of characters specified under Data type in the case of character strings includes the final \0.

Char10 means that the text is up to 9 characters long. The final \0 character is then added to this

User level

| Address | Access | Data type | Signal reference | Parameter |
|---------|--------|-----------|------------------|--------------------------------|
| 0x0000 | R/O | Float | X1 | Analog input InP1 |
| 0x0002 | R/O | Float | X2 | Analog input InP2 |
| 0x0004 | R/O | Float | X3 | Analog input InP2 |
| 0x0006 | R/O | Float | WR | Actual setpoint |
| 0x0008 | R/W | Float | SP1 | Setpoint 1 |
| 0x000A | R/W | Float | SP2 (= dSP) | Setpoint 2 |
| 0x1035 | R/O | Float | --- | Analog input InP3 (unfiltered) |
| 0x1043 | R/O | Float | --- | Actual angular positioning |
| 0x1058 | R/O | Word | B1 | Burner alarm |

Parameter level

| Address | Access | Data type | Signal reference | Parameter |
|---------|--------|-----------|------------------|-------------------------------------|
| 0x3000 | R/W | Float | Pb1 | Proportional range 1 |
| 0x3004 | R/W | Float | dt | Derivative action time |
| 0x3006 | R/W | Float | rt | Integral action time |
| 0x300C | R/W | Float | db | Dead band |
| 0x3012 | R/W | Word | tt | Controlling element running time |
| | | | | |
| 0x3016 | R/W | Float | HYS1 | Switch-on threshold |
| 0x3018 | R/W | Float | HYS2 | Switch-off threshold down |
| 0x301A | R/W | Float | HYS3 | Switch-off threshold up |
| 0x301C | R/W | Float | HYS4 | Switch-on threshold (cooling) |
| 0x301E | R/W | Float | HYS5 | Switch-off threshold down (cooling) |
| 0x3020 | R/W | Float | HYS6 | Switch-off threshold up (cooling) |
| 0x3022 | R/W | Float | q | Reaction threshold |
| | | | | |
| 0x3080 | R/W | Float | At1 | Outside temperature 1 |
| 0x3082 | R/W | Float | Ht2 | Boiler temperature 1 |
| 0x3084 | R/W | Float | At2 | Outside temperature 2 |
| 0x3086 | R/W | Float | Ht2 | Boiler temperature 2 |

Configuration level

| Address | Access | Data type | Signal reference | Parameter |
|---------|--------|-----------|------------------|---|
| 0x3426 | R/W | Float | SCL1 | Start of display input 1 |
| 0x3428 | R/W | Float | SCH1 | End of display input 1 |
| 0x3432 | R/W | Float | SCL2 | Start value input 2 |
| 0x3434 | R/W | Float | SCH2 | End value input 2 |
| 0x3486 | R/W | Float | SPL | Start of setpoint limitation |
| 0x3488 | R/W | Float | SPH | End of setpoint limitation |
| 0x342A | R/W | Float | OFFS1 | Offset input E1 |
| 0x3436 | R/W | Float | OFFS2 | Offset input E2 |
| 0x343A | R/W | Float | OFFS3 | Offset input E3 |
| | | | | |
| 0x1063 | R/W | Word | FnCt | Ramp function |
| 0x1065 | R/W | Float | rASL | Ramp slope |
| 0x1067 | R/W | Float | toLP | Tolerance band ramp |
| 0x1069 | R/W | Float | rAL | Limit value |
| 0x1075 | R/W | Float | dtT | Remote Detection Timer |
| | | | | |
| 0x1077 | R/W | Float | dF1 | Filter constant input 1 |
| 0x1079 | R/W | Float | dF2 | Filter constant input 2 |
| 0x107B | R/W | Float | dF3 | Filter constant input 3 |
| 0x107D | R/O | Float | oLLo | Lower working range limit |
| 0x107F | R/O | Float | oLHi | Upper working range limit |
| | | | | |
| 0x106D | R/W | Word | FnCt | Alarm relay function |
| 0x106F | R/W | Float | AL | Alarm relay limit value (limit value alarm) |
| 0x1071 | R/W | Float | HYSt | Alarm relay hysteresis |

Remote operation

| Address | Access | Data type | Signal reference | Parameter |
|---------|--------|-----------|------------------|---|
| 0x0500 | R/W | Word | REM | Activation remote operation * |
| 0x0501 | R/W | Word | rOFF | Controller OFF in remote setpoint ** |
| 0x0502 | R/W | Float | rHYS1 | Switch-on threshold remote |
| 0x0504 | R/W | Float | rHYS2 | Switch-off threshold down remote |
| 0x0506 | R/W | Float | rHYS3 | Switch-off threshold up remote |
| 0x0508 | R/W | Float | SPr | Setpoint remote |
| | | | | |
| 0x050A | R/W | Word | RK1 | Burner release remote operation |
| 0x050B | R/W | Word | RK2 | Relay K2 remote operation |
| 0x050C | R/W | Word | RK3 | Relay K3 remote operation |
| 0x050D | R/W | Word | RK6 | Relay K6 remote operation |
| 0x050E | R/W | Word | rStEP | Step-by-step control remote operation |
| 0x050F | R/W | Float | rY | Angular positioning output remote operation |
| 0x0511 | R/W | Float | rHYS4 | Switch-on threshold remote (cooling) |
| 0x0513 | R/W | Float | rHYS5 | Switch-off threshold down remote (cooling) |
| 0x0515 | R/W | Float | rHYS6 | Switch-off threshold up remote (cooling) |

Legend

* = Local

** = Controller OFF

Dati dell'apparecchio

| Address | Access | Data type | Signal reference | Parameter |
|---------|--------|-----------|------------------|------------------|
| 0x8000 | R/O | Char12 | --- | Software version |
| 0x8006 | R/O | Char14 | --- | VdN number |

Stato dell'apparecchio

| Address | Access | Data type | Signal reference | Parameter |
|---------|--------|-----------|------------------|---------------------------------------|
| 0x0200 | R/O | Word | --- | Outputs and states |
| | | | Bit 0 | Output 1 |
| | | | Bit 1 | Output 3 |
| | | | Bit 2 | Output 2 |
| | | | Bit 3 | Output 4 |
| | | | Bit 8 | Hysteresis limitation |
| | | | Bit 9 | Control system |
| | | | Bit 10 | Self-optimization |
| | | | Bit 11 | Second setpoint |
| | | | Bit 12 | Measuring range overshoot InP1 |
| | | | Bit 13 | Measuring range overshoot InP2 |
| | | | Bit 14 | Measuring range overshoot InP3 |
| | | | Bit 15 | Calibration mode |
| 0x0201 | R/O | Word | --- | Binary signals and hardware detection |
| | | | Bit 0 | Operation mode 2-stage |
| | | | Bit 1 | Manual mode |
| | | | Bit 2 | Binary input D1 |
| | | | Bit 3 | Binary input D2 |
| | | | Bit 4 | Thermostat function |
| | | | Bit 5 | First controller output |
| | | | Bit 6 | Second controller output |
| | | | Bit 7 | Alarm relay |
| | | | Bit 13 | Analog output available |
| | | | Bit 14 | Interface available |

Electric connections :

With 7 pins connector version

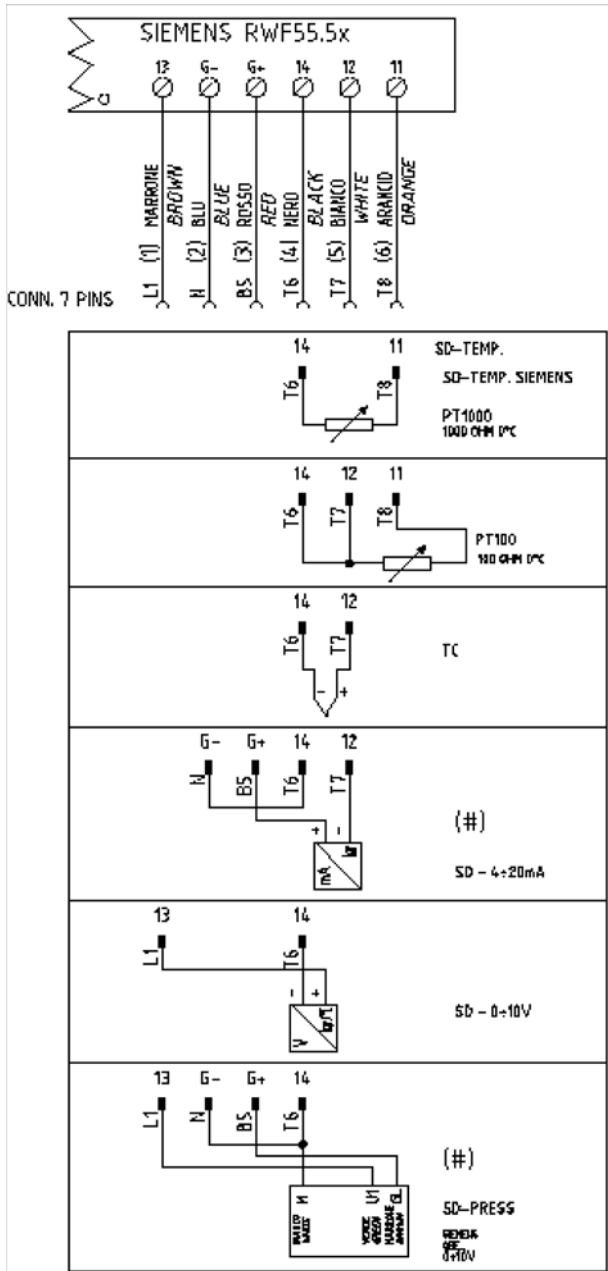

With terminals version

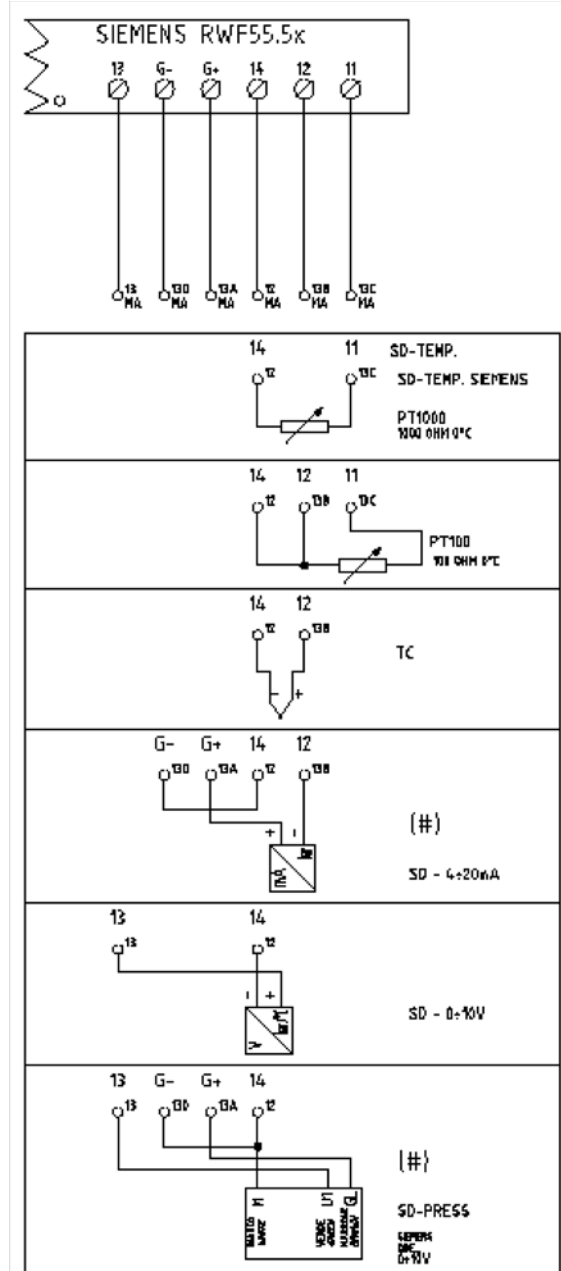

Correspondences bornes entre RWF55.5x y RWF40.0x0 Matches terminals between RWF55.5x and RWF40.0x0

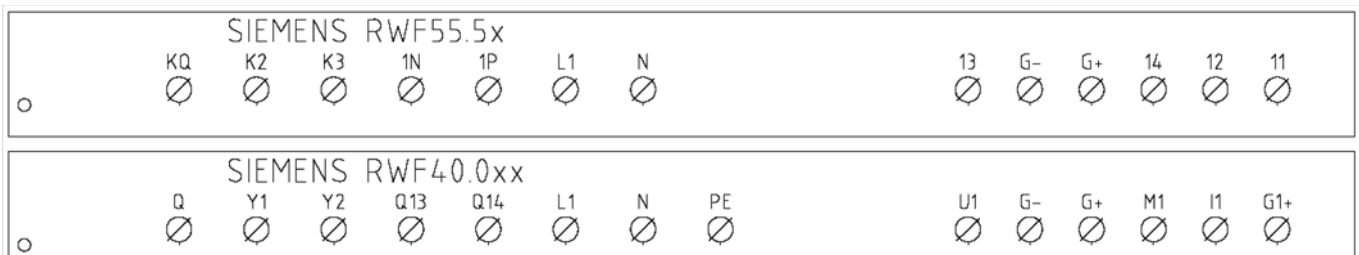

Parameters summarising for RWF55.xx :

| Navigation menu | ConF | | | | | ConF | | | PArA | | | | | | Opr |
|------------------------|------|------|----------|----------|----------|----------|----------|----------|-------|----|-----|-----|----------|----------|-------------|
| | Inp | | | | | Cntr | | diSP | PArA | | | | | | Opr |
| | Inp1 | | | | | | | | PArA | | | | | | |
| | SEn1 | OFF1 | SCL | SCH | Unit | SPL | SPH | dECP | Pb. 1 | dt | rt | tt | HYS1 (*) | HYS3 (*) | SP1 (*) |
| Siemens QAE2120... | 6 | 0 | needless | needless | 1 | 30 | 95 | 1 | 10 | 80 | 350 | (#) | -5 | 5 | 80 °C |
| Siemens QAM2120.. | 6 | 0 | needless | needless | 1 | 0 | 80 | 1 | 10 | 80 | 350 | (#) | -2,5 | 2,5 | 40°C |
| Pt1000 (130°C max.) | 4 | 0 | needless | needless | 1 | 30 | 95 | 1 | 10 | 80 | 350 | (#) | -5 | 5 | 80°C |
| Pt1000 (350°C max.) | 4 | 0 | needless | needless | 1 | 0 | 350 | 1 | 10 | 80 | 350 | (#) | -5 | 10 | 80°C |
| Pt100 (130°C max.) | 1 | 0 | needless | needless | 1 | 0 | 95 | 1 | 10 | 80 | 350 | (#) | -5 | 5 | 80°C |
| Pt100 (350°C max) | 1 | 0 | needless | needless | 1 | 0 | 350 | 1 | 10 | 80 | 350 | (#) | -5 | 10 | 80°C |
| Probe4+20mA / 0+1,6bar | 16 | 0 | 0 | 160 | needless | 0 | 160 | 0 | 5 | 20 | 80 | (#) | 0 | 20 | 100 kPa |
| Probe4+20mA / 0+3bar | 16 | 0 | 0 | 300 | needless | 0 | 300 | 0 | 5 | 20 | 80 | (#) | 0 | 20 | 200 kPa |
| Probe 4+20mA / 0+10bar | 16 | 0 | 0 | 1000 | needless | 0 | 1000 | 0 | 5 | 20 | 80 | (#) | 0 | 50 | 600 kPa |
| Probe 4+20mA / 0+16bar | 16 | 0 | 0 | 1600 | needless | 0 | 1600 | 0 | 5 | 20 | 80 | (#) | 0 | 80 | 600 kPa |
| Probe 4+20mA / 0+25bar | 16 | 0 | 0 | 2500 | needless | 0 | 2500 | 0 | 5 | 20 | 80 | (#) | 0 | 125 | 600 kPa |
| Probe 4+20mA / 0+40bar | 16 | 0 | 0 | 4000 | needless | 0 | 4000 | 0 | 5 | 20 | 80 | (#) | 0 | 200 | 600 kPa |
| Probe 4+20mA / 0+60PSI | 16 | 0 | 0 | 600 | needless | 0 | 600 | 0 | 5 | 20 | 80 | (#) | 0 | 30 | 300 (30PSI) |
| Probe4+20mA / 0+200PSI | 16 | 0 | 0 | 2000 | needless | 0 | 2000 | 0 | 5 | 20 | 80 | (#) | 0 | 75 | 600 (60PSI) |
| Probe4+20mA / 0+300PSI | 16 | 0 | 0 | 3000 | needless | 0 | 3000 | 0 | 5 | 20 | 80 | (#) | 0 | 120 | 600 (60PSI) |
| Siemens QBE2002 P4 | 17 | 0 | 0 | 400 | needless | 0 | 400 | 0 | 5 | 20 | 80 | (#) | 0 | 20 | 200 kPa |
| Siemens QBE2002 P10 | 17 | 0 | 0 | 1000 | needless | 0 | 1000 | 0 | 5 | 20 | 80 | (#) | 0 | 50 | 600 kPa |
| Siemens QBE2002 P16 | 17 | 0 | 0 | 1600 | needless | 0 | 1600 | 0 | 5 | 20 | 80 | (#) | 0 | 80 | 600 kPa |
| Siemens QBE2002 P25 | 17 | 0 | 0 | 2500 | needless | 0 | 2500 | 0 | 5 | 20 | 80 | (#) | 0 | 125 | 600 kPa |
| Siemens QBE2002 P40 | 17 | 0 | 0 | 4000 | needless | 0 | 4000 | 0 | 5 | 20 | 80 | (#) | 0 | 200 | 600 kPa |
| Signal 0+10V | 17 | 0 | needless | needless | needless | needless | needless | needless | 5 | 20 | 80 | (#) | | | |
| Signal 4+20mA | 16 | 0 | needless | needless | needless | needless | needless | needless | 5 | 20 | 80 | (#) | | | |

NOTE:

(#) tt – servo control run time

SQL33 ; STM30; SQM10; SQM40; SQM50; SQM54 = 30 (secondi) - STA12B3.41; SQN30.251; SQN72.4A4A20 = 12 (secondi)

(*)These values are factory set - values must be set during operation at the plant based on the real working temperature/pressure value.

WARNING :

With pressure probes in bar the parameters SP1, SCH, SCL, HYS1, HYS3 must be set and displayed in kPa (kilo Pascal); 1bar = 100,000Pa = 100kPa.

With pressure probes in PSI the parameters SP1, SCH, SCL, HYS1, HYS3 must be set and displayed in PSI x10 (example: 150PSI > I display 1500).

APPENDIX: PROBES CONNECTION

To assure the utmost comfort, the control system needs reliable information, which can be obtained provided the sensors have been installed correctly. Sensors measure and transmit all variations encountered at their location.

Measurement is taken based on design features (time constant) and according to specific operating conditions. With wiring run in raceways, the sheath (or pipe) containing the wires must be plugged at the sensor's terminal board so that currents of air cannot affect the sensor's measurements.

Ambient probes (or ambient thermostats)

Installation

The sensors (or room thermostats) must be located in reference rooms in a position where they can take real temperature measurements without being affected by foreign factors.

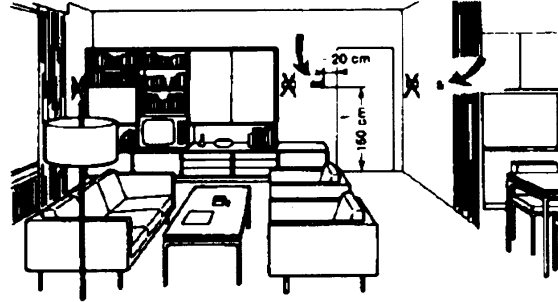
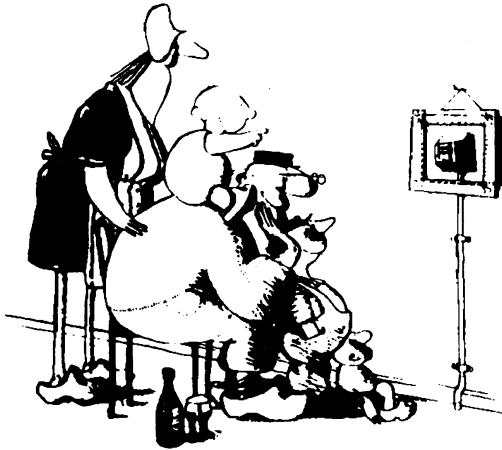

Outside probes (weather) Installation

In heating or air-conditioning systems featuring adjustment in response to outside temperature, the sensor's positioning is of paramount importance.

It's good to be admired ...even better to be effective

Heating systems: the room sensor must not be installed in rooms with heating units complete with thermostatic valves. Avoid all sources of heat foreign to the system.

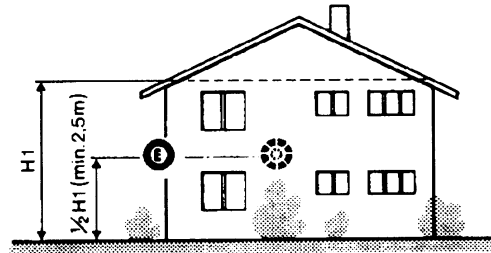
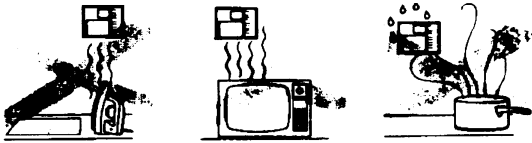

General rule: en on the outer wall of the building where the living rooms are, never on the south-facing wall or in a position where they will be affected by morning sun. If in any doubt, place them on the north or north-east façade.

Positions to be avoided

Location

On an inner wall on the other side of the room to heating units height above floor 1.5 m, at least 1.5 m away from external sources of heat (or cold).

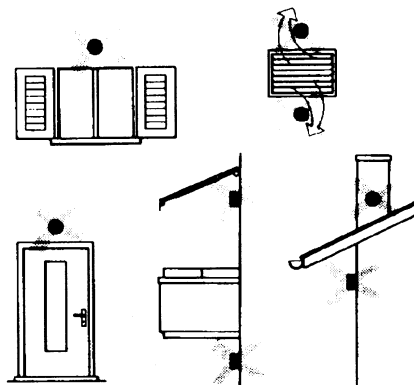
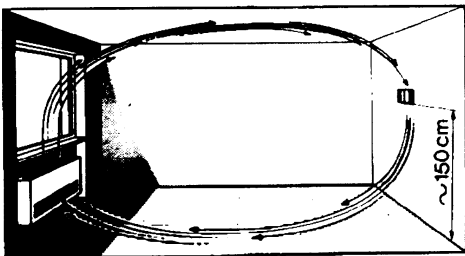

Installation position to be avoided

near shelving or alcoves and recesses, near doors or windows, inside outer walls exposed to solar radiation or currents of cold air, on inner walls with heating system pipes, domestic hot water pipes, or cooling system pipes running through them.

Avoid installing near windows, vents, outside the boiler room, on chimney breasts or where they are protected by balconies, cantilever roofs .

The sensor must not be painted (measurement error) .

Duct or pipe sensors

Installing temperature sensors

For measuring outlet air:

"after delivery fan or

"after coil to be controlled, at a distance of at least 0,5 m

For measuring room temperature:

"before return air intake fan and near room's return airintake.

For measuring saturation temperature: after mist eliminator.

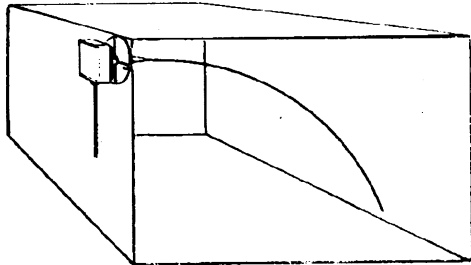

Bend 0.4m sensor by hand (never use tools) as illustrated .

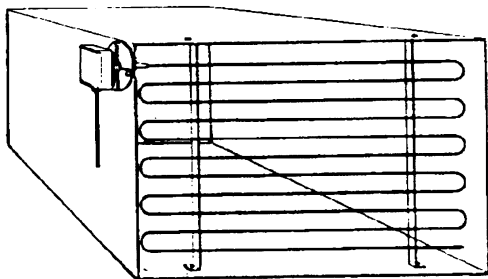

Use whole cross-section of duct, min. distance from walls 50 mm, radius of curvature 10 mm for 2m or 6m sensors

Installing combined humidity sensors

As max. humidity limit sensor on outlet (steam humidifiers) .

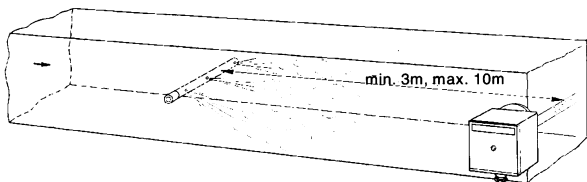

Installing pressure sensors

A - installation on ducts carrying fluids at max. temperature 80°C

B - installation on ducts at temperature over 80°C and for refrigerants

C - installation on ducts at high temperatures :

· "increase length of siphon

"place sensor at side to prevent it being hit by hot air coming from the pipe.

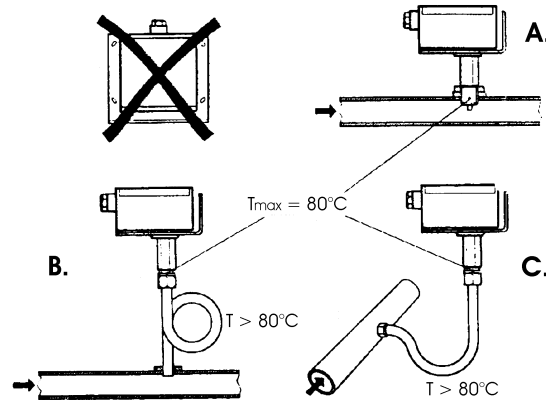

Installing differential pressure sensors for water

Installation with casing facing down not allowed.

With temperature over 80°C, siphons are needed.

To avoid damaging the sensor, you must comply with the following instructions :

when installing: make sure pressure difference is not greater than the value permitted by the sensor

when there are high static pressures, make sure you insert shutoff valves A-B-C.

Putting into operation

Start disable

1=open C1=open C

2=open A2=close B

3=open B3=close A

4= close C

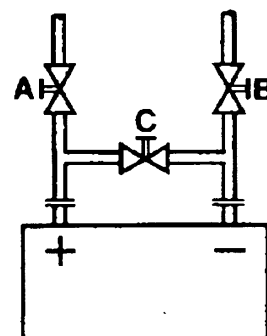

Immersion or strap-on sensors

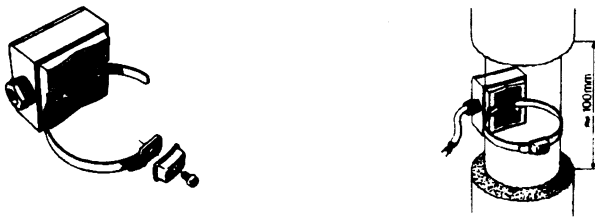
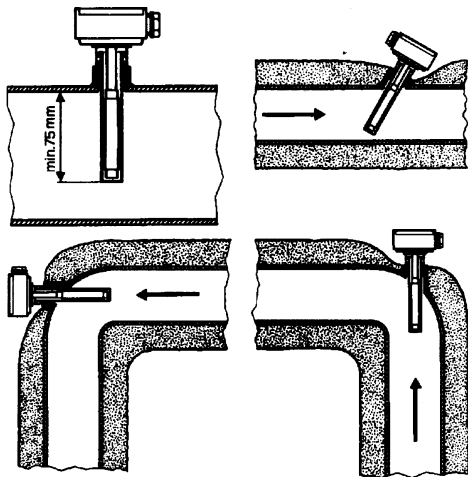

Immersion probes installation

Sensors must be installed on the stretch of pipe in which fluid circulates all the time.

The rigid stem (sensing element doing the measuring) must be inserted by at least 75mm and must face the direction of flow.

Recommended locations: on a bend or on a straight stretch of pipe but tilted by 45° and against the flow of fluid.

Protect them to prevent water from infiltrating (dripping gates, condensation from pipes etc.) .

Installing QAD2.. strap-on sensors

Make sure fluid is circulating in the chosen location.

Eliminate insulation and paintwork (including rust inhibitor) on a min. 100mm length of pipe.

Sensors come with straps for pipes up to 100 mm in diameter .

Placing the probes (QAD22.../QAE21.../QAP21.../RCA...)

With pumps on outlet

with 3 ways valves / with 4 ways valves



Panel system / burner control

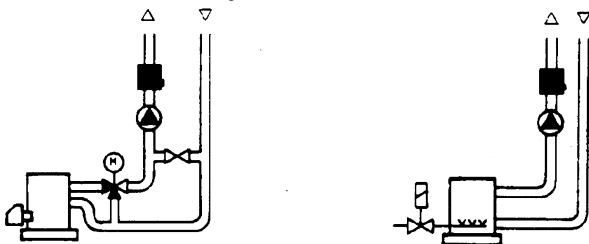

With pumps on return

with 3 ways valves / with 4 ways valves



Strap-on or immersion sensors?

QAD2.. strap-on sensors

Advantages :

- 10 sec. time constant
- Installed with system running (no plumbing work)
- Installation can be changed easily if it proves incorrect

ΠLimits:

- Suitable for pipe diameters max. 100 mm
- Can be affected by currents of air etc.

QAE2... immersion sensors

Advantages:

- Measure "mean" fluid temperature
- No external influence on measurement such as: currents of air, nearby pipes etc.

Limits:

- Time constant with sheath: 20 sec.
- Hard to change installation position if it proves incorrect

Installing differential pressure probes for air

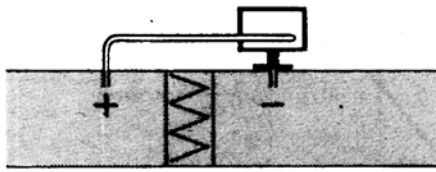

A - Control a filter (clogging)

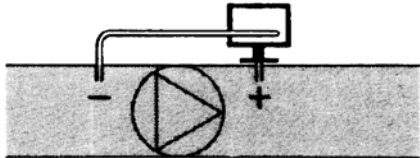

B - Control a fan (upstream/downstream)

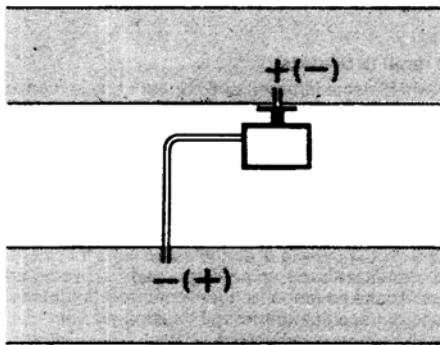

C - Measurement of difference in pressure between two ducts

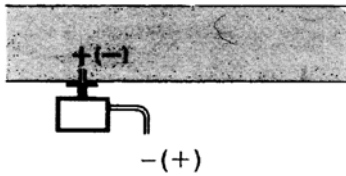

D - Measurement of difference in pressure between two rooms or of inside of duct and outside

Basic principles

Measuring static pressure (i.e. pressure exerted by air on pipe walls)

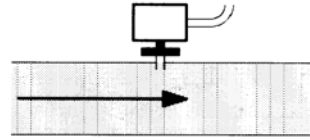

Measuring dynamic pressure

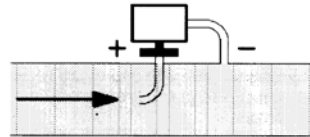

$$P_d = \frac{\gamma v^2}{2g}$$

Legend

- y Kg/m³, specific weight of air
- q m/s, air speed
- g 9.81 m/s² gravity acceleration
- P_d mm C.A., dynamic pressure

Measuring total pressure

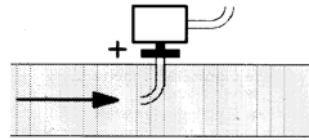

Note: Specifications and data subject to change. Errors and omissions excepted.

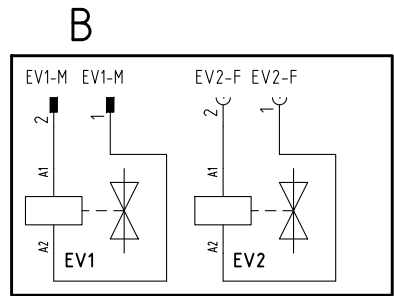
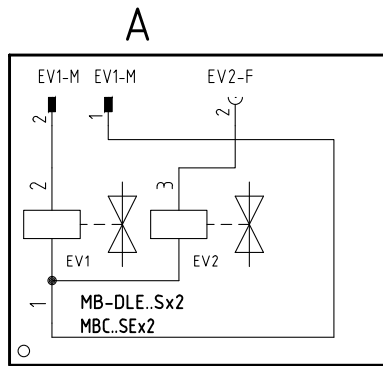
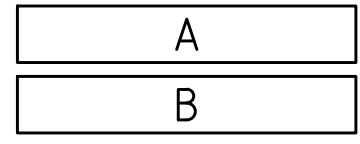
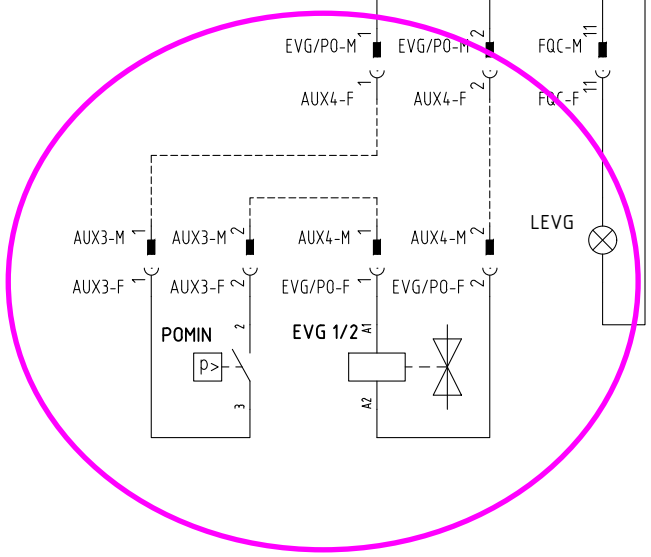
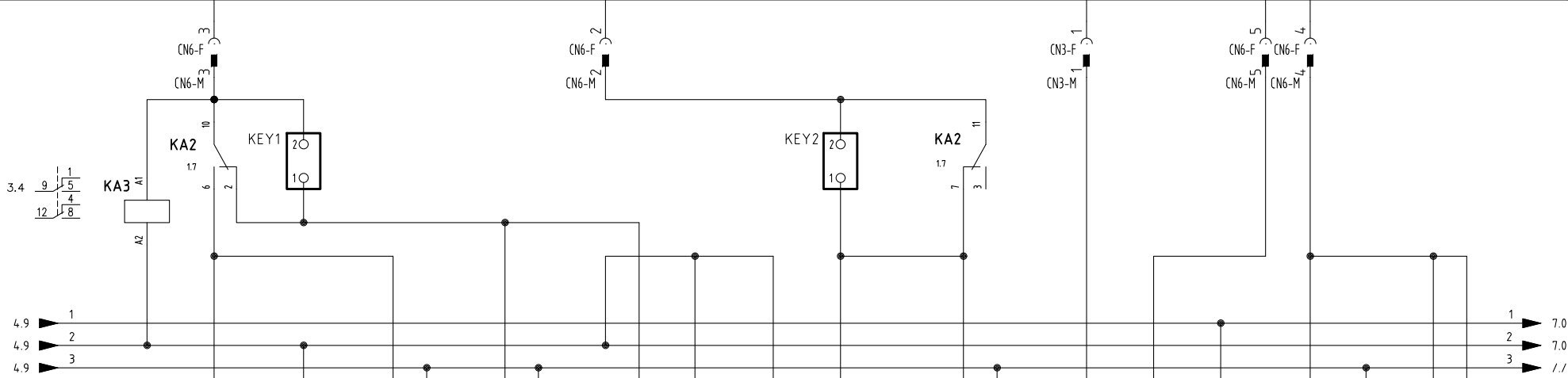
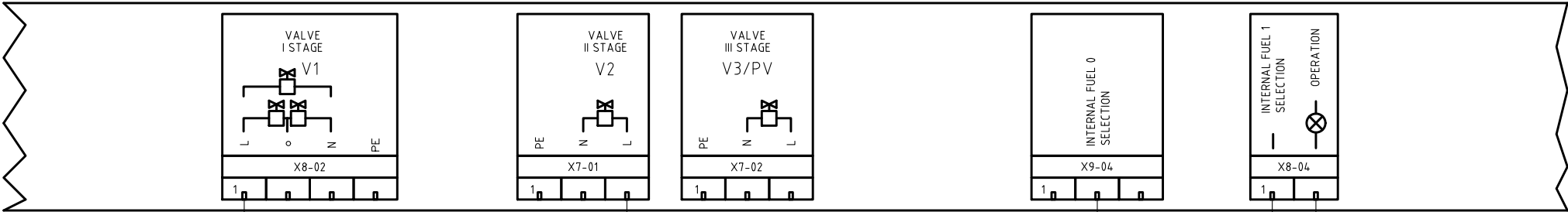

| | | | |
|-----------|------------|-------|--------|
| Data | 23/11/2022 | PREC. | FOGLIO |
| Revisione | 00 | 4 | 5 |
| Dis. N. | 05 - 1399 | SEGUE | TOTALE |
| | | 6 | 13 |

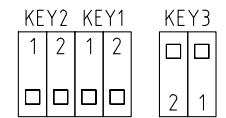
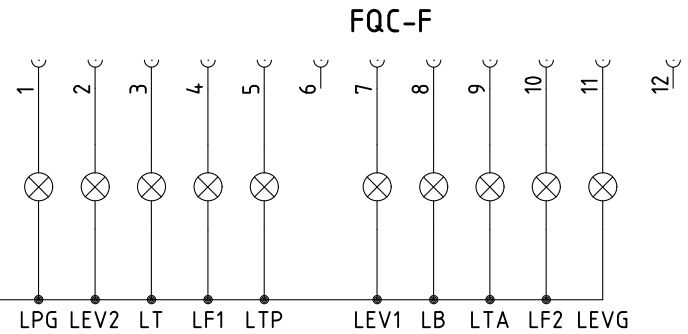
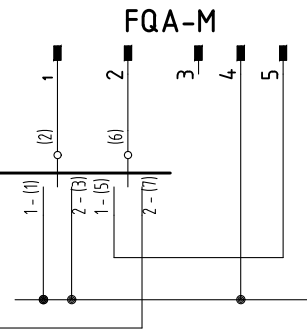
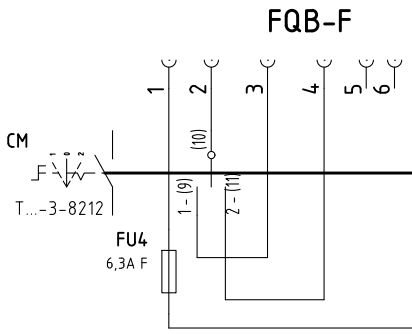
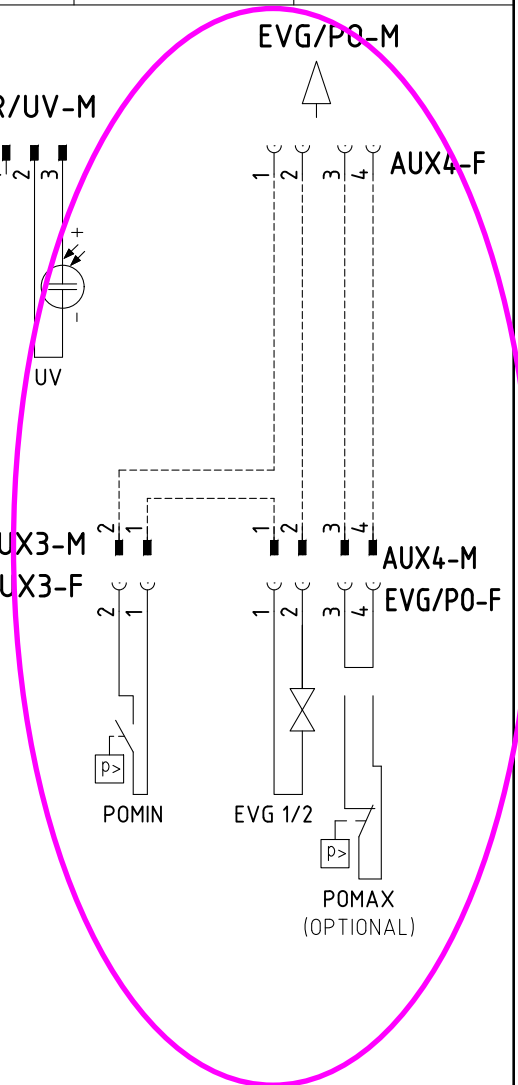
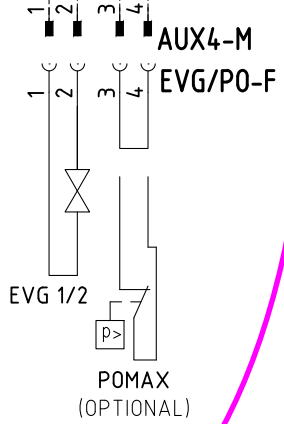
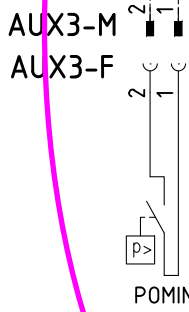
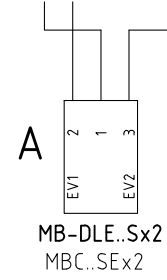
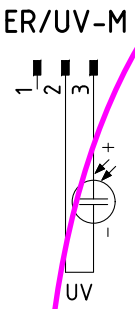
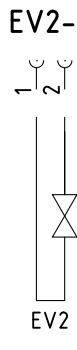
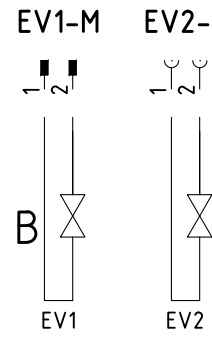
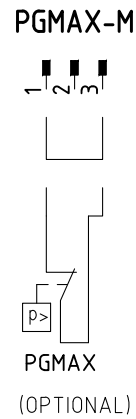
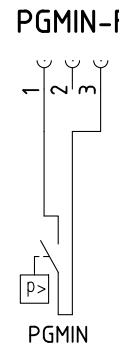
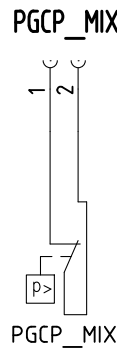
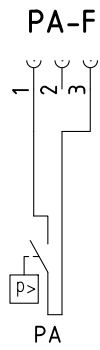
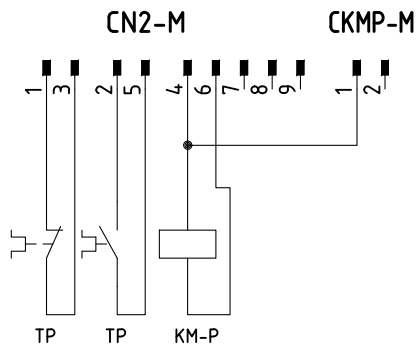
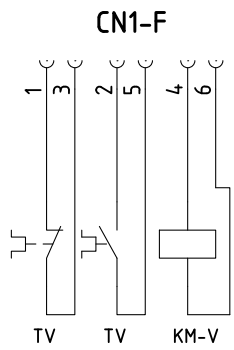

| | | | |
|-----------|------------|-------|--------|
| Data | 23/11/2022 | PREC. | FOGLIO |
| Revisione | 00 | 9 | 10 |
| Dis. N. | 05 - 1399 | SEGUE | TOTALE |
| | | 11 | 13 |